

120 FOOT TEMPORARY EASEMENT

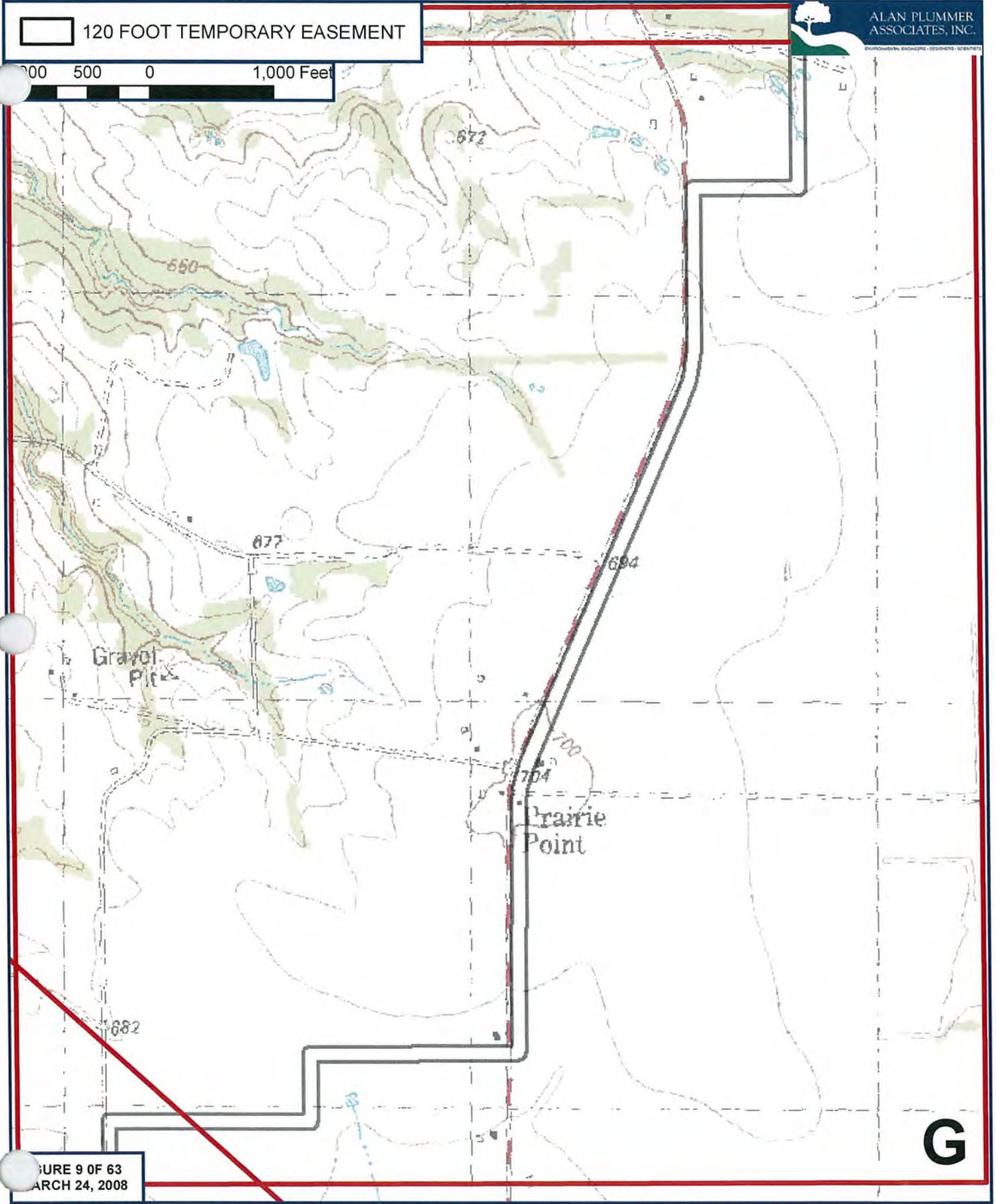
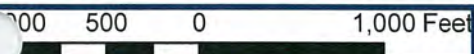
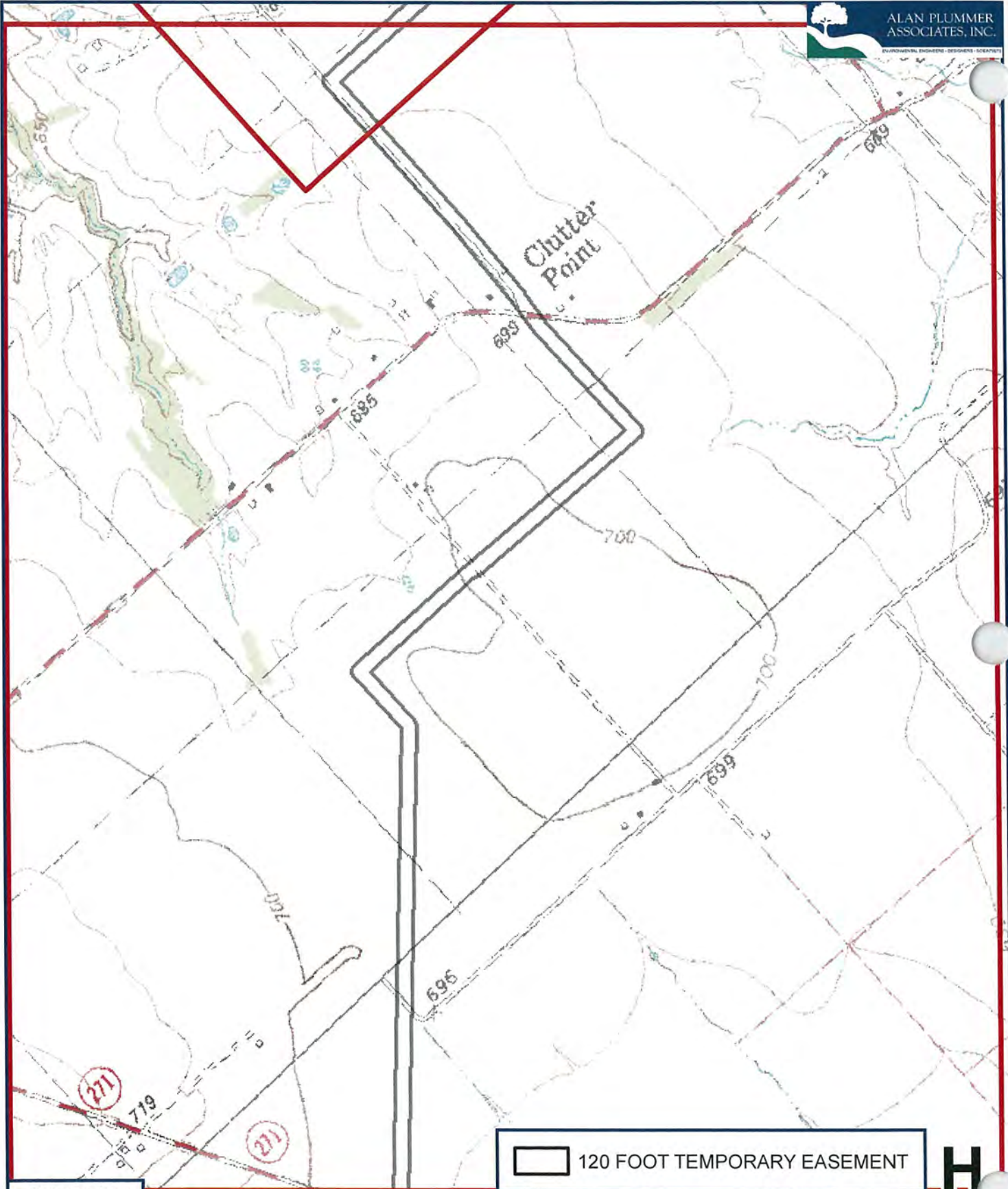

FIGURE 9 OF 63
MARCH 24, 2008

A-9
PJD LIMITS, USGS TOPOGRAPHIC MAP
PROPOSED BOIS D'ARC RESERVOIR - RAW WATER TRANSMISSION PIPELINE



120 FOOT TEMPORARY EASEMENT

1,000 500 0 1,000 Feet

A-10

PJD LIMITS, USGS TOPOGRAPHIC MAP
PROPOSED BOIS D'ARC RESERVOIR - RAW WATER TRANSMISSION PIPELINE

FIGURE 10 OF 63
MARCH 24, 2008



FIGURE 11 OF 63
MARCH 24, 2008



A-11
PJD LIMITS, USGS TOPOGRAPHIC MAP
PROPOSED BOIS D'ARC RESERVOIR - RAW WATER TRANSMISSION PIPELINE

120 FOOT TEMPORARY EASEMENT

1,000 500 0 1,000 Feet

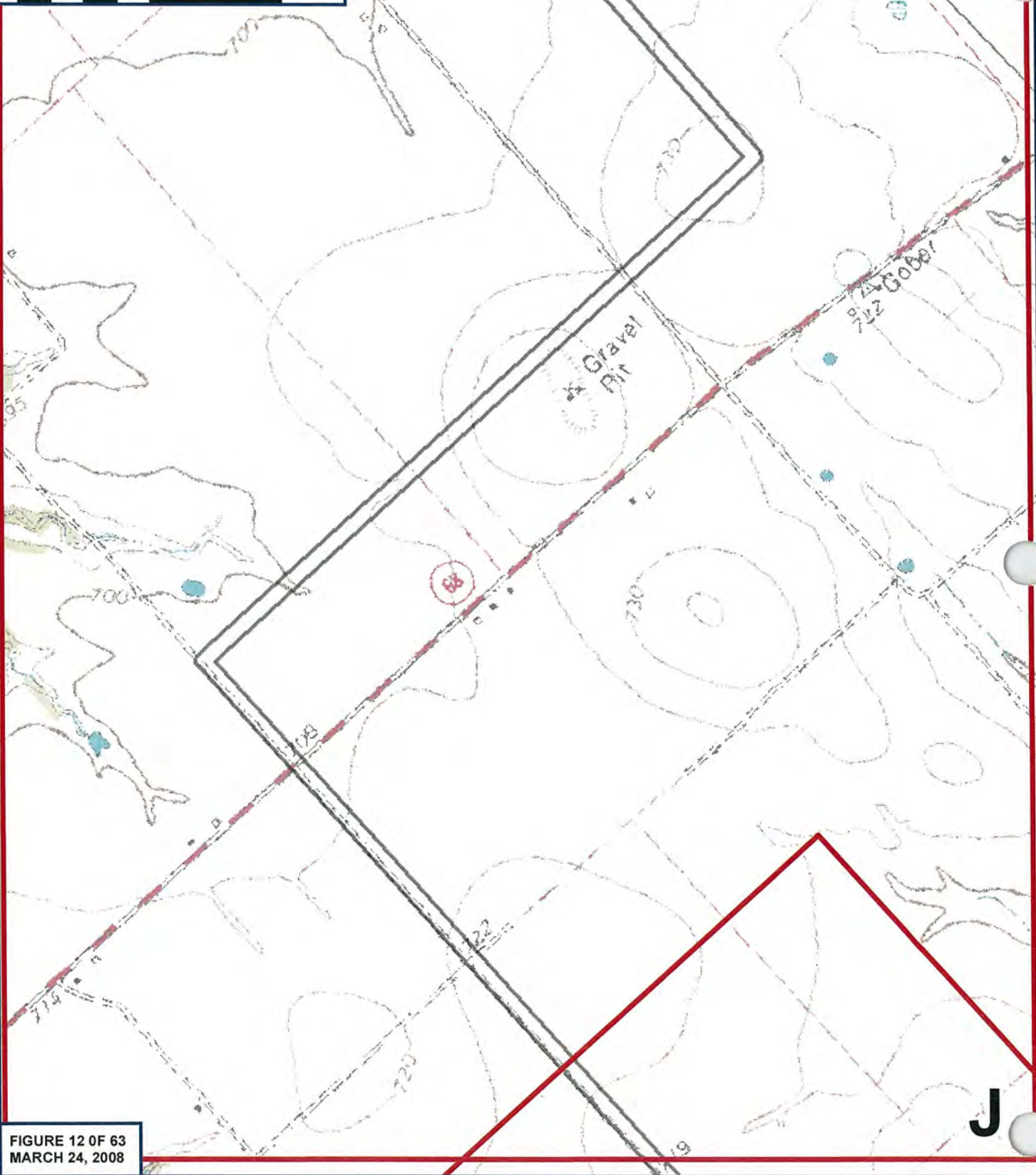

FIGURE 12 OF 63
MARCH 24, 2008

120 FOOT TEMPORARY EASEMENT

0 500 0 1,000 Feet

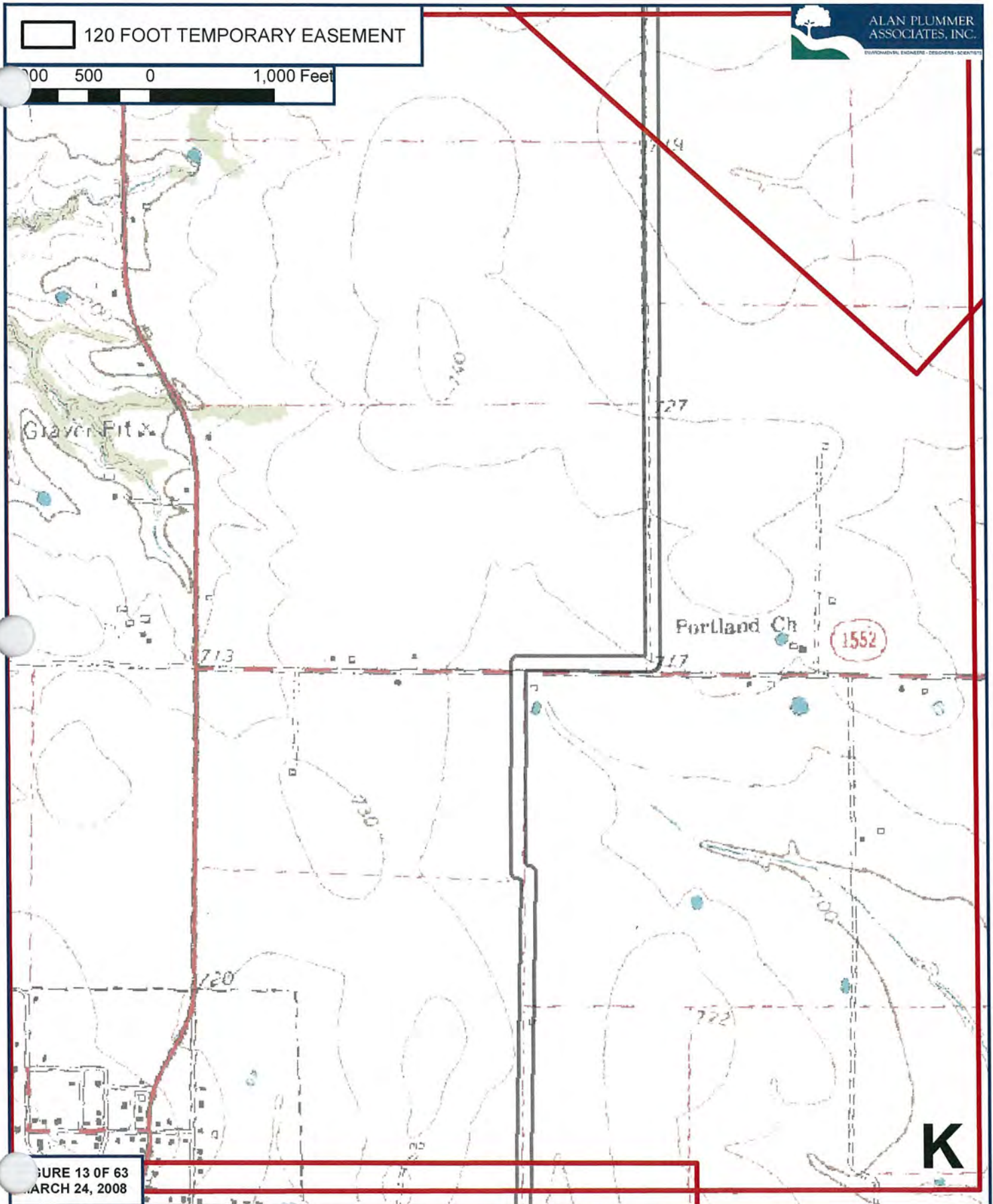

FIGURE 13 OF 63
MARCH 24, 2008

A-13
PJD LIMITS, USGS TOPOGRAPHIC MAP
PROPOSED BOIS D'ARC RESERVOIR - RAW WATER TRANSMISSION PIPELINE

120 FOOT TEMPORARY EASEMENT

1,000 500 0 1,000 Feet

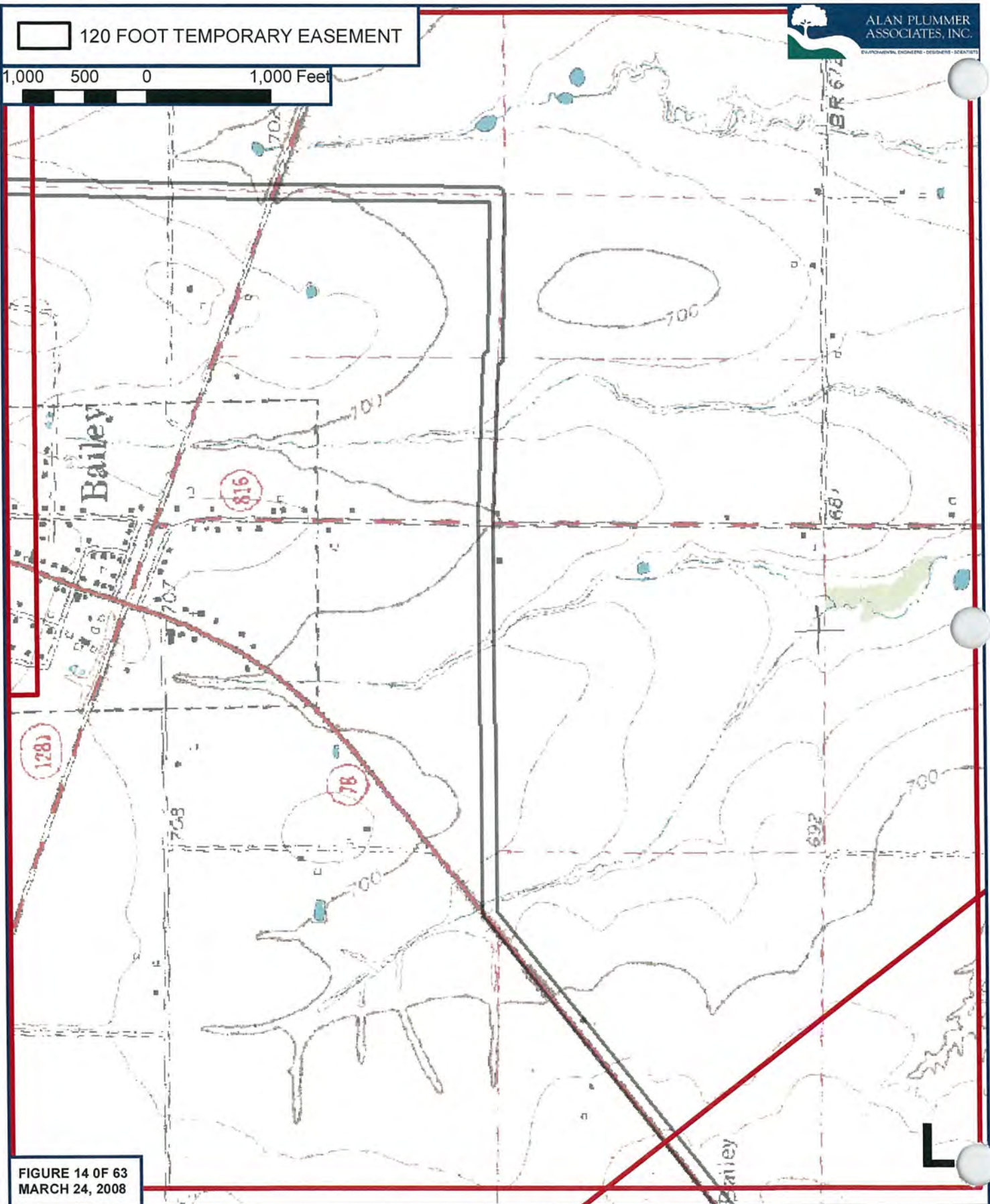

FIGURE 14 OF 63
MARCH 24, 2008

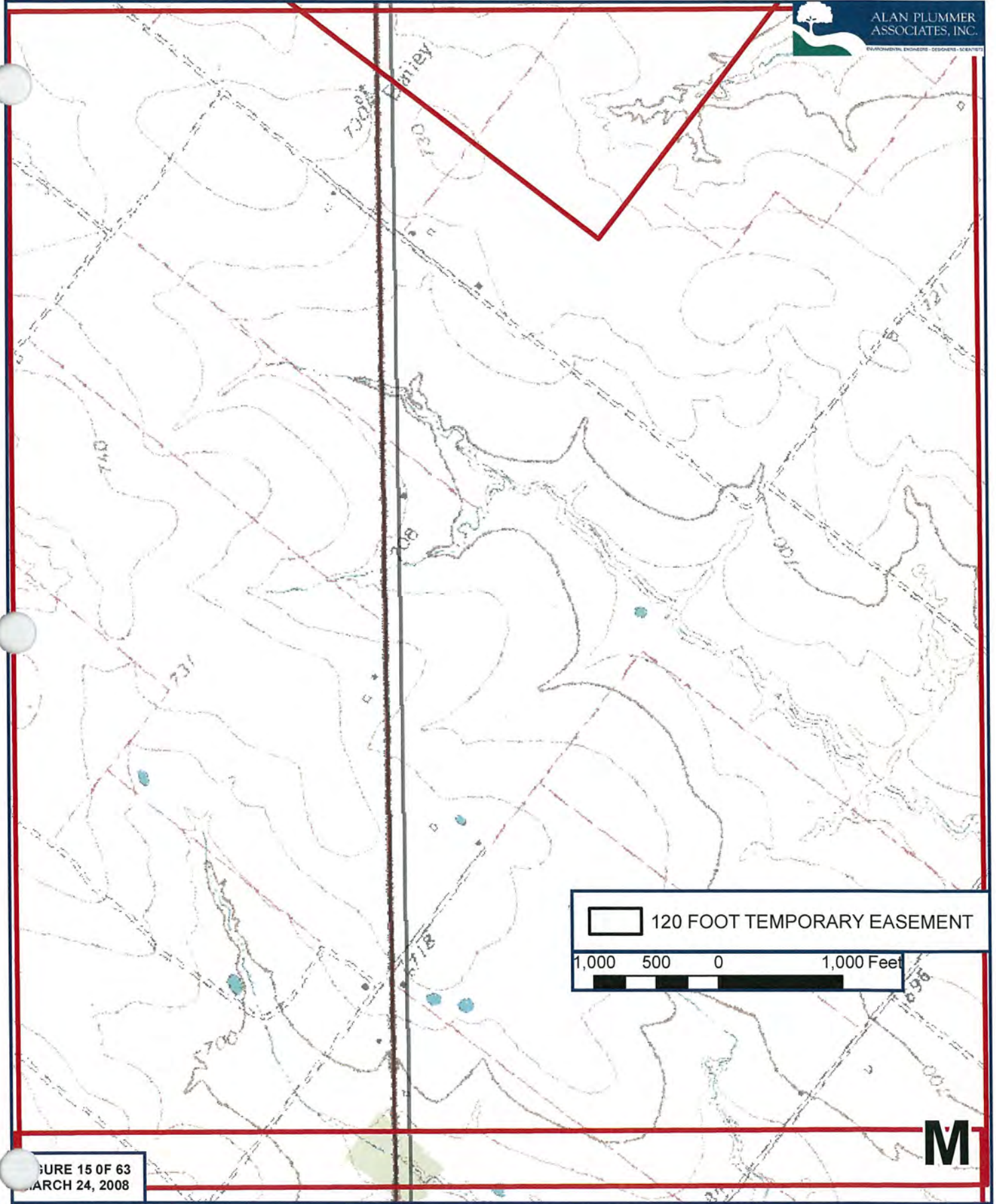

FIGURE 15 OF 63
MARCH 24, 2008

M

A-15
PJD LIMITS, USGS TOPOGRAPHIC MAP
PROPOSED BOIS D'ARC RESERVOIR - RAW WATER TRANSMISSION PIPELINE

120 FOOT TEMPORARY EASEMENT

1,000 500 0 1,000 Feet

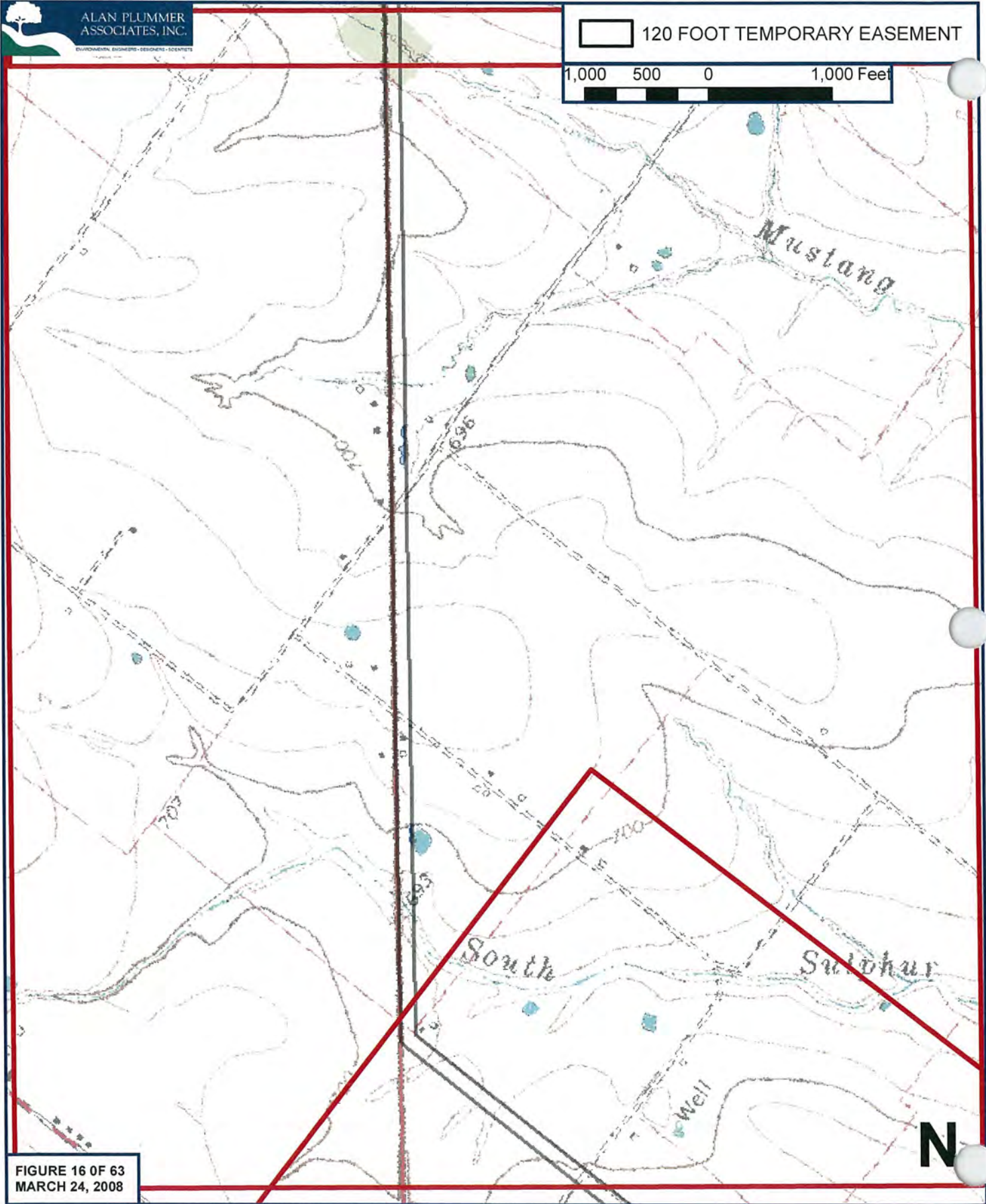

FIGURE 16 OF 63
MARCH 24, 2008

120 FOOT TEMPORARY EASEMENT

0 500 0 1,000 Feet

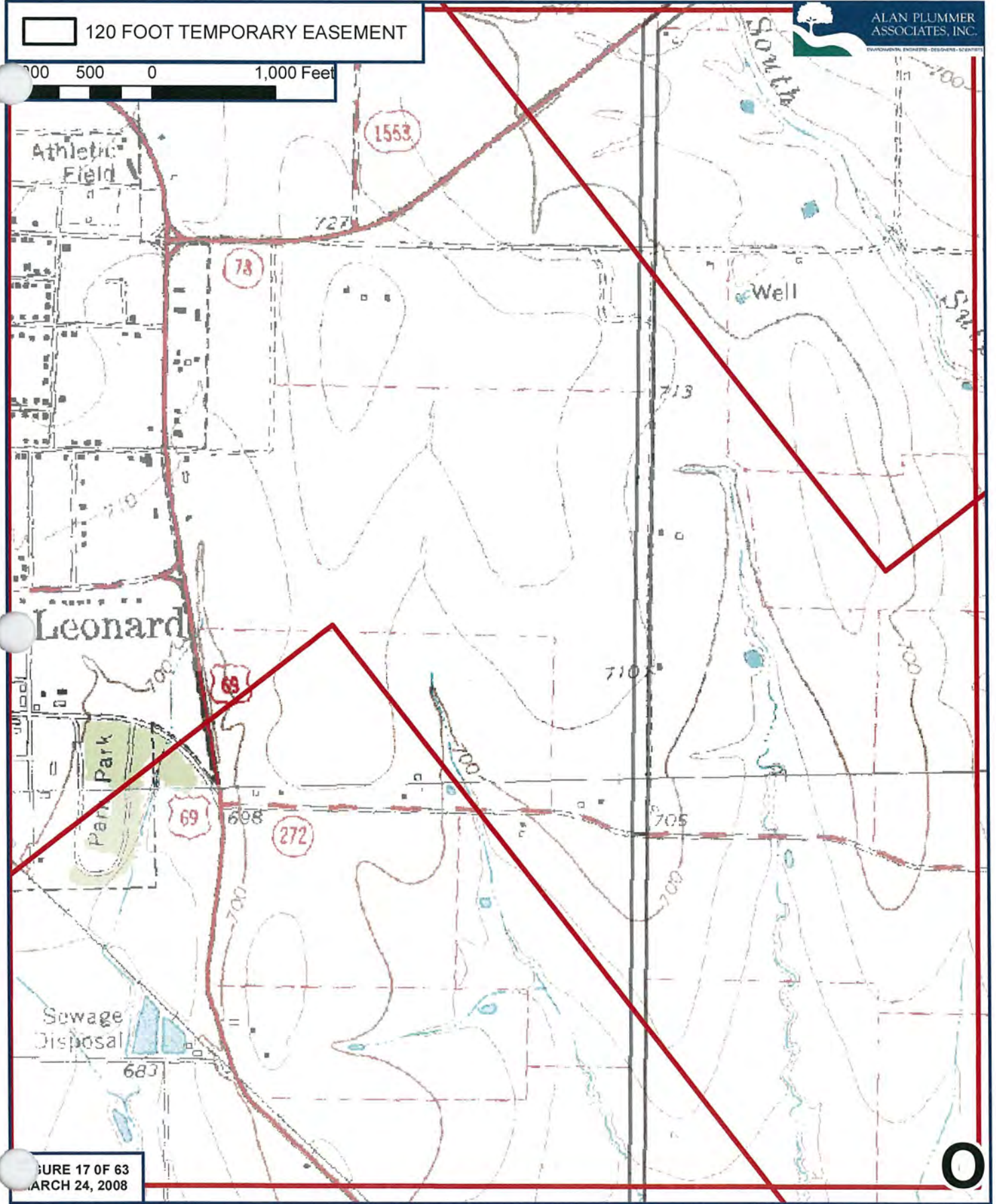

FIGURE 17 OF 63
MARCH 24, 2008

A-17
PJD LIMITS, USGS TOPOGRAPHIC MAP
PROPOSED BOIS D'ARC RESERVOIR - RAW WATER TRANSMISSION PIPELINE

120 FOOT TEMPORARY EASEMENT

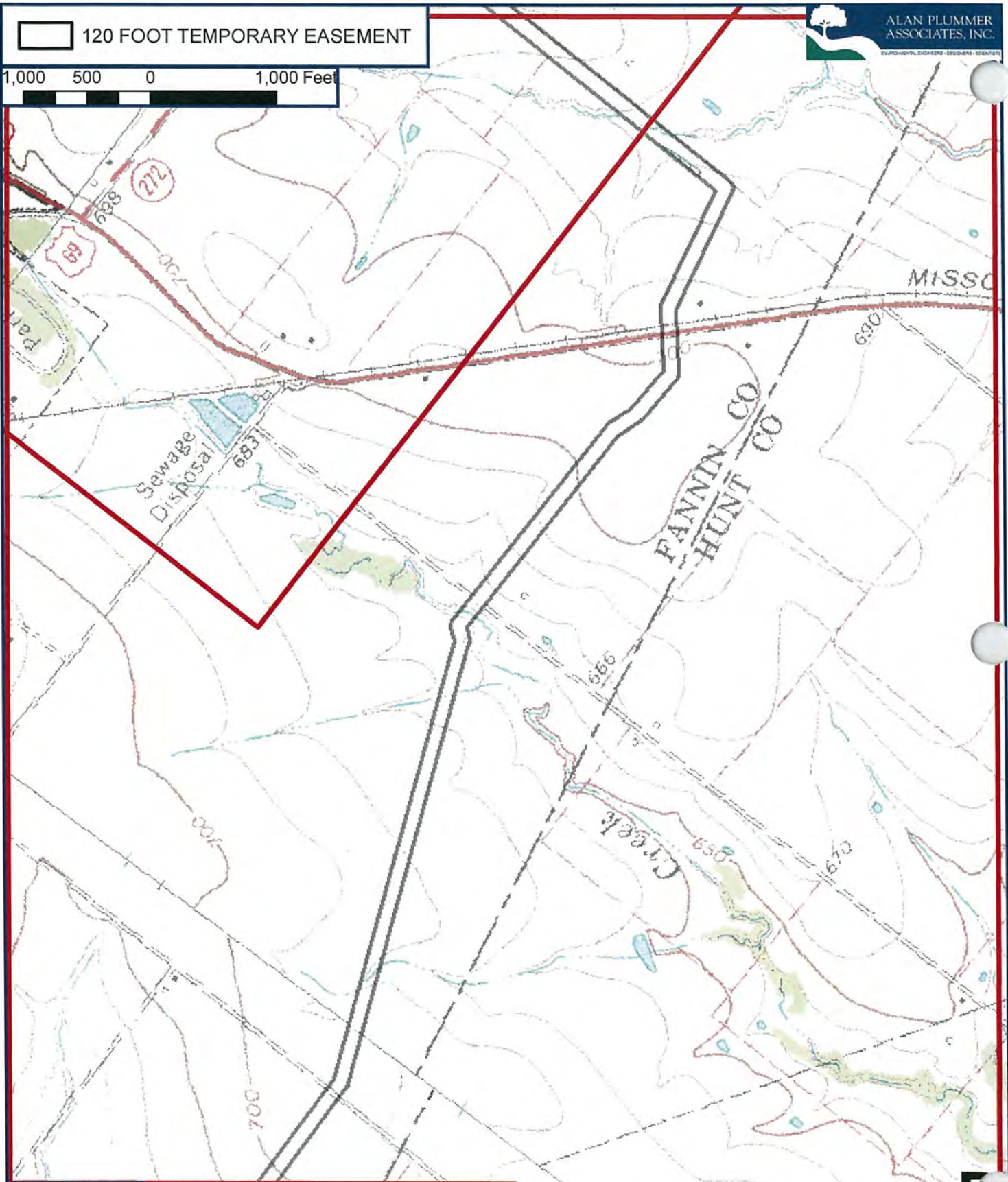
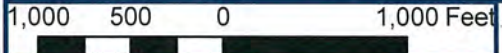

FIGURE 18 OF 63
MARCH 24, 2008

120 FOOT TEMPORARY EASEMENT



ALAN PLUMMER ASSOCIATES, INC.
SURVEYING ENGINEERS - DESIGNERS - SCIENTISTS

0 500 0 1,000 Feet

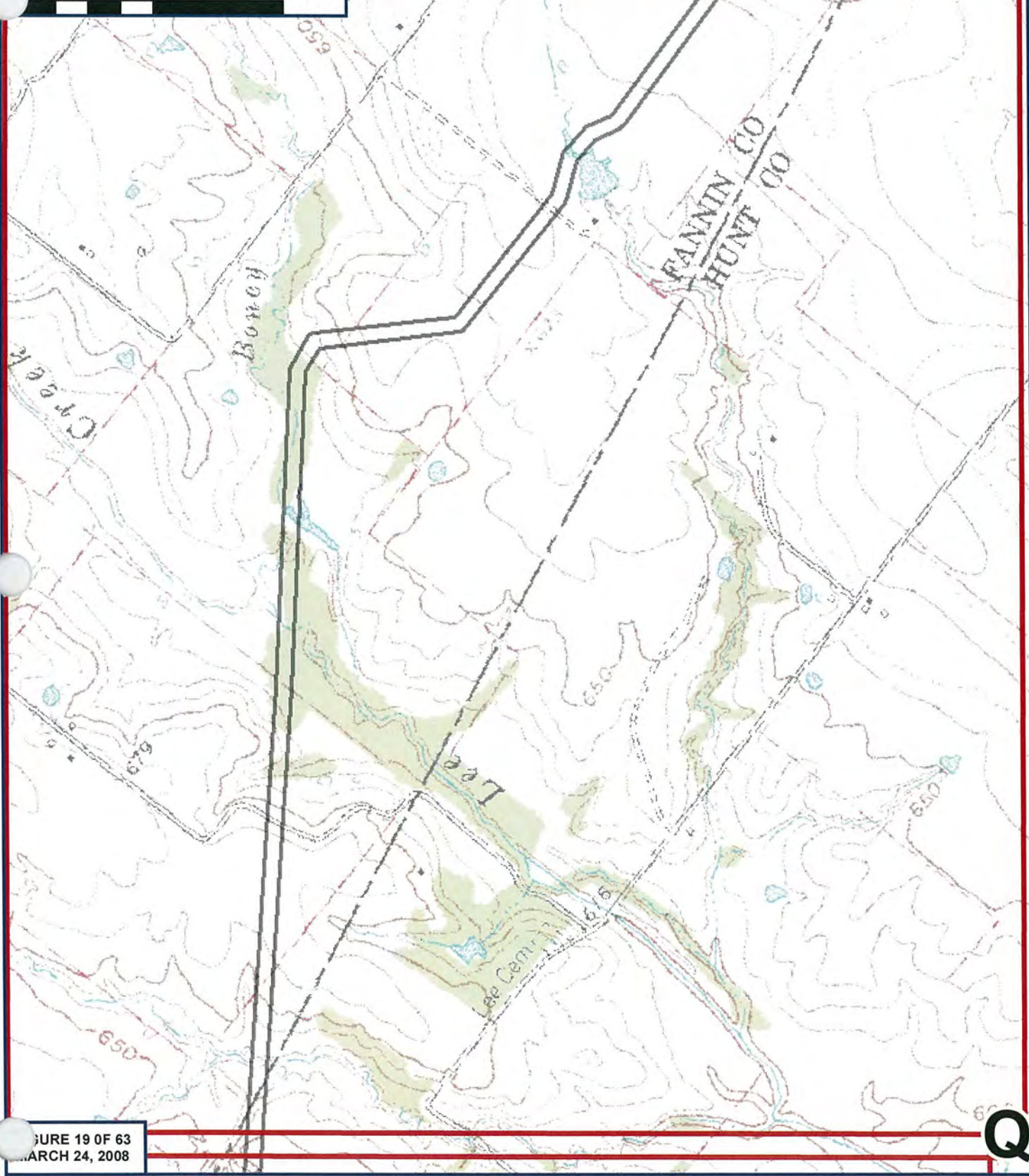

FIGURE 19 OF 63
MARCH 24, 2008

A-19
PJD LIMITS, USGS TOPOGRAPHIC MAP
PROPOSED BOIS D'ARC RESERVOIR - RAW WATER TRANSMISSION PIPELINE

120 FOOT TEMPORARY EASEMENT

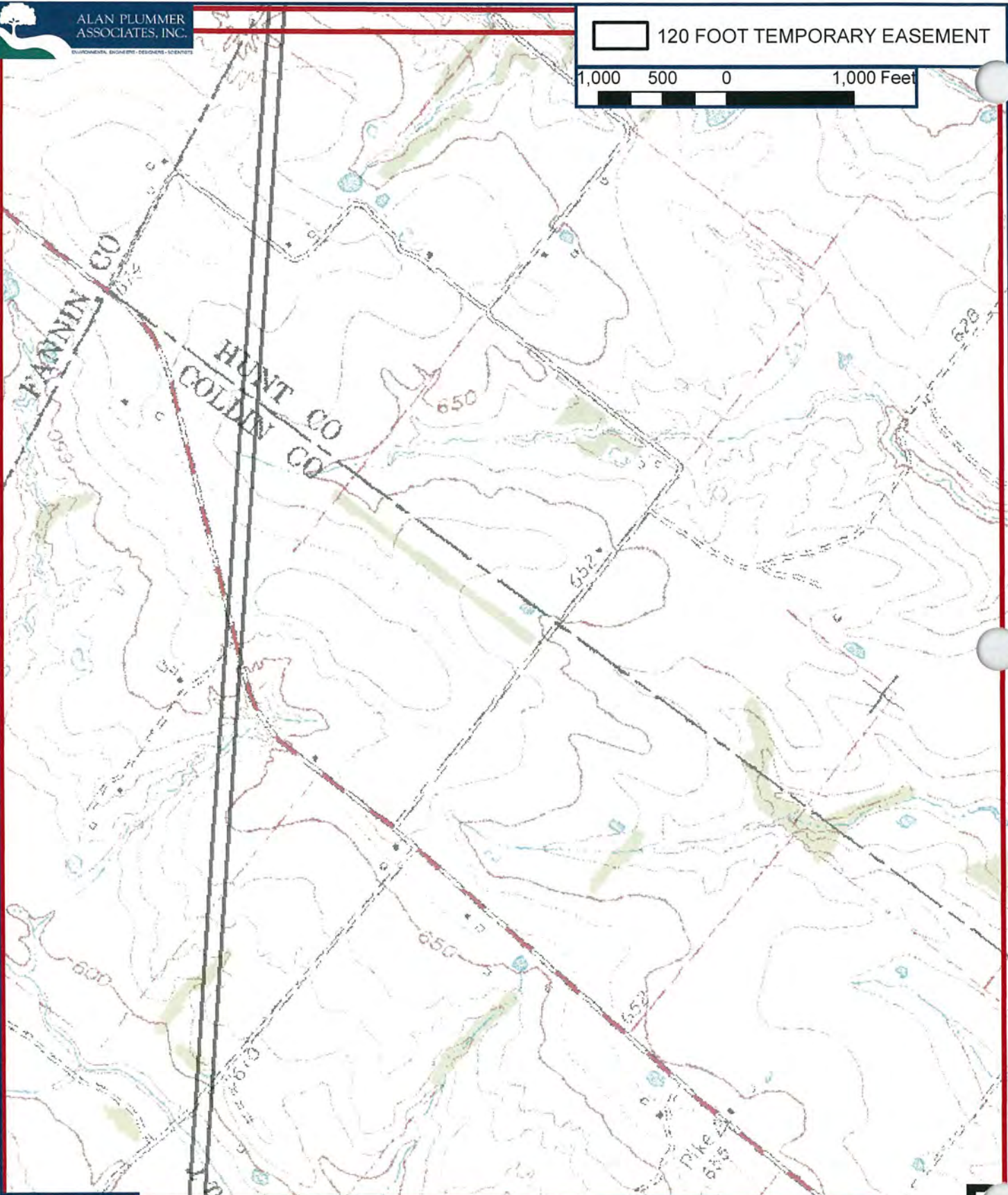

FIGURE 20 OF 63
MARCH 24, 2008

A-20
PJD LIMITS, USGS TOPOGRAPHIC MAP
PROPOSED BOIS D'ARC RESERVOIR - RAW WATER TRANSMISSION PIPELINE

120 FOOT TEMPORARY EASEMENT

1,000 500 0 1,000 Feet

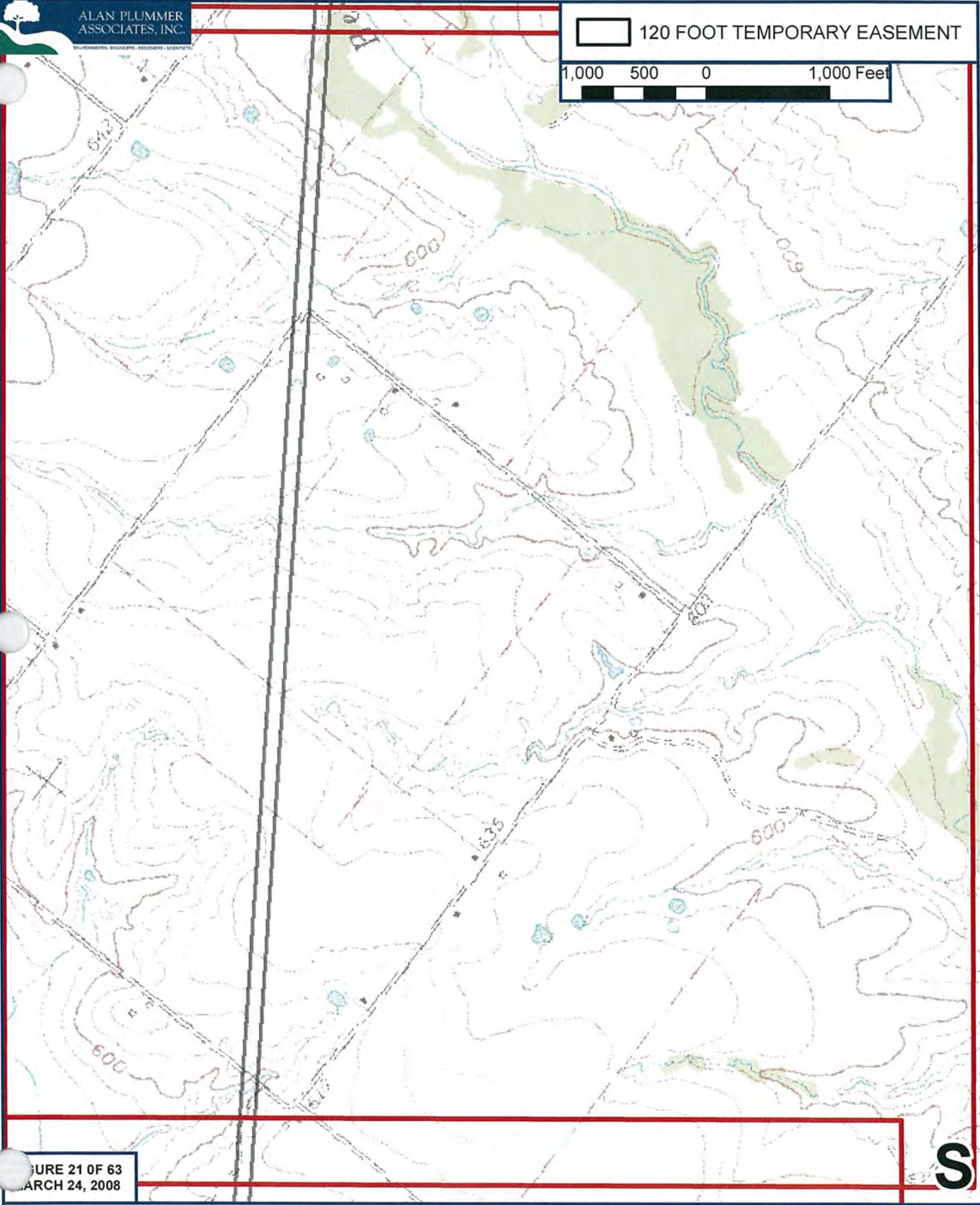

FIGURE 21 OF 63
MARCH 24, 2008

A-21
PJD LIMITS, USGS TOPOGRAPHIC MAP
PROPOSED BOIS D'ARC RESERVOIR - RAW WATER TRANSMISSION PIPELINE



ALAN PLUMMER
ASSOCIATES, INC.

ENVIRONMENTAL ENGINEERS - DESIGNERS - SCIENTISTS

120 FOOT TEMPORARY EASEMENT

1,000 500 0 1,000 Feet

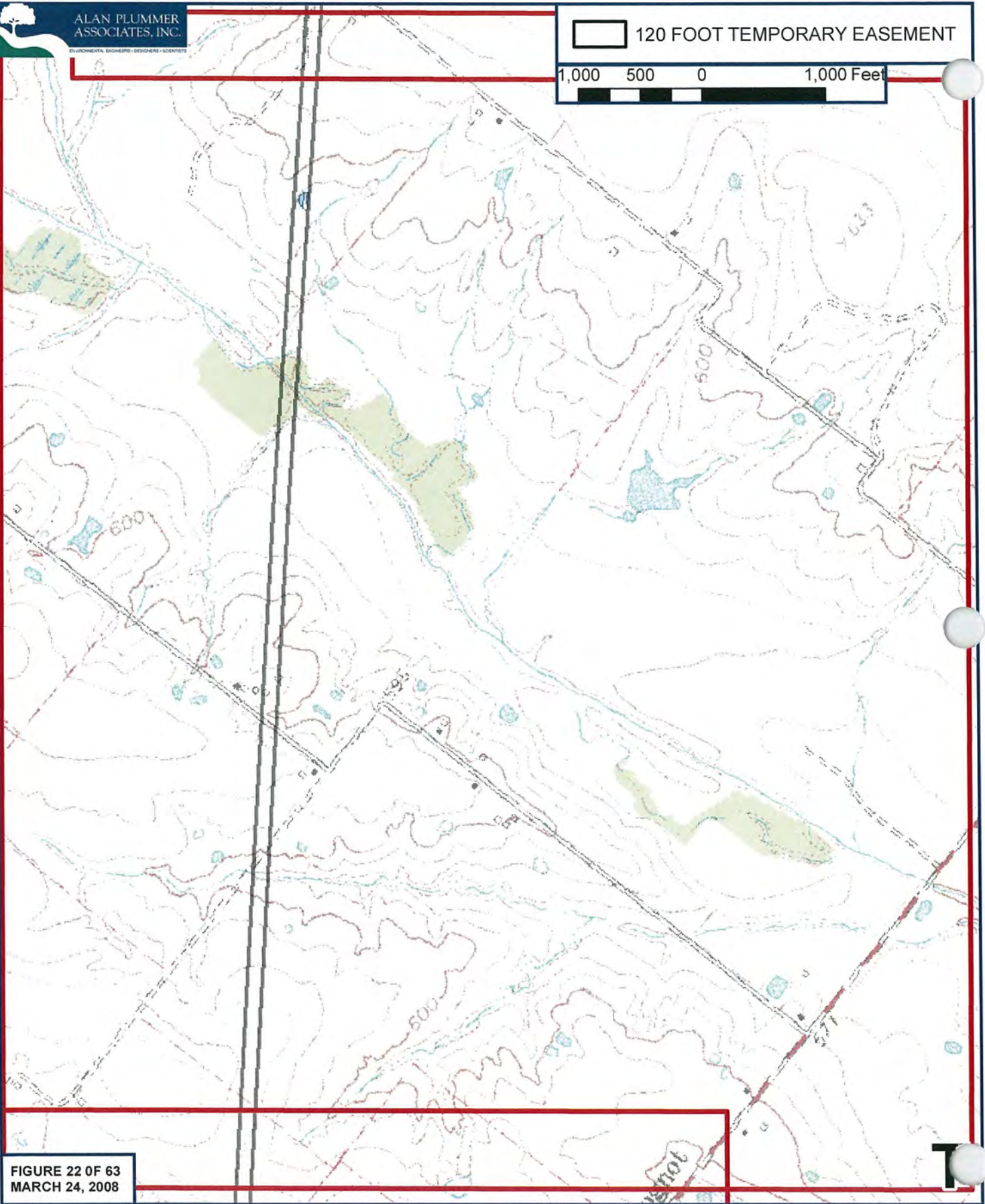
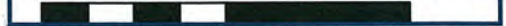
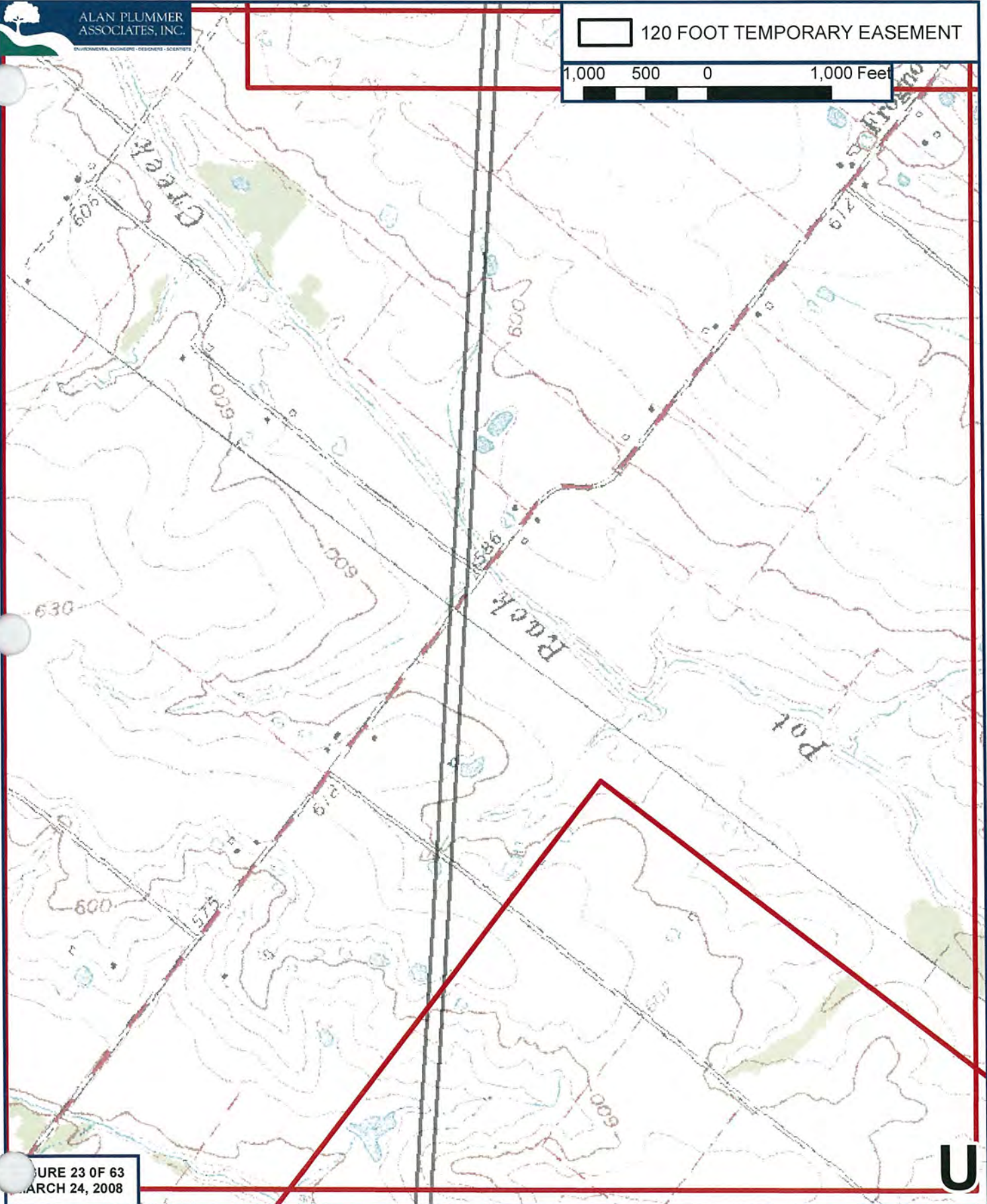

FIGURE 22 OF 63
MARCH 24, 2008

A-22
PJD LIMITS, USGS TOPOGRAPHIC MAP
PROPOSED BOIS D'ARC RESERVOIR - RAW WATER TRANSMISSION PIPELINE

120 FOOT TEMPORARY EASEMENT

1,000 500 0 1,000 Feet



URE 23 OF 63
MARCH 24, 2008

U

A-23
PJD LIMITS, USGS TOPOGRAPHIC MAP
PROPOSED BOIS D'ARC RESERVOIR - RAW WATER TRANSMISSION PIPELINE

120 FOOT TEMPORARY EASEMENT

1,000 500 0 1,000 Feet

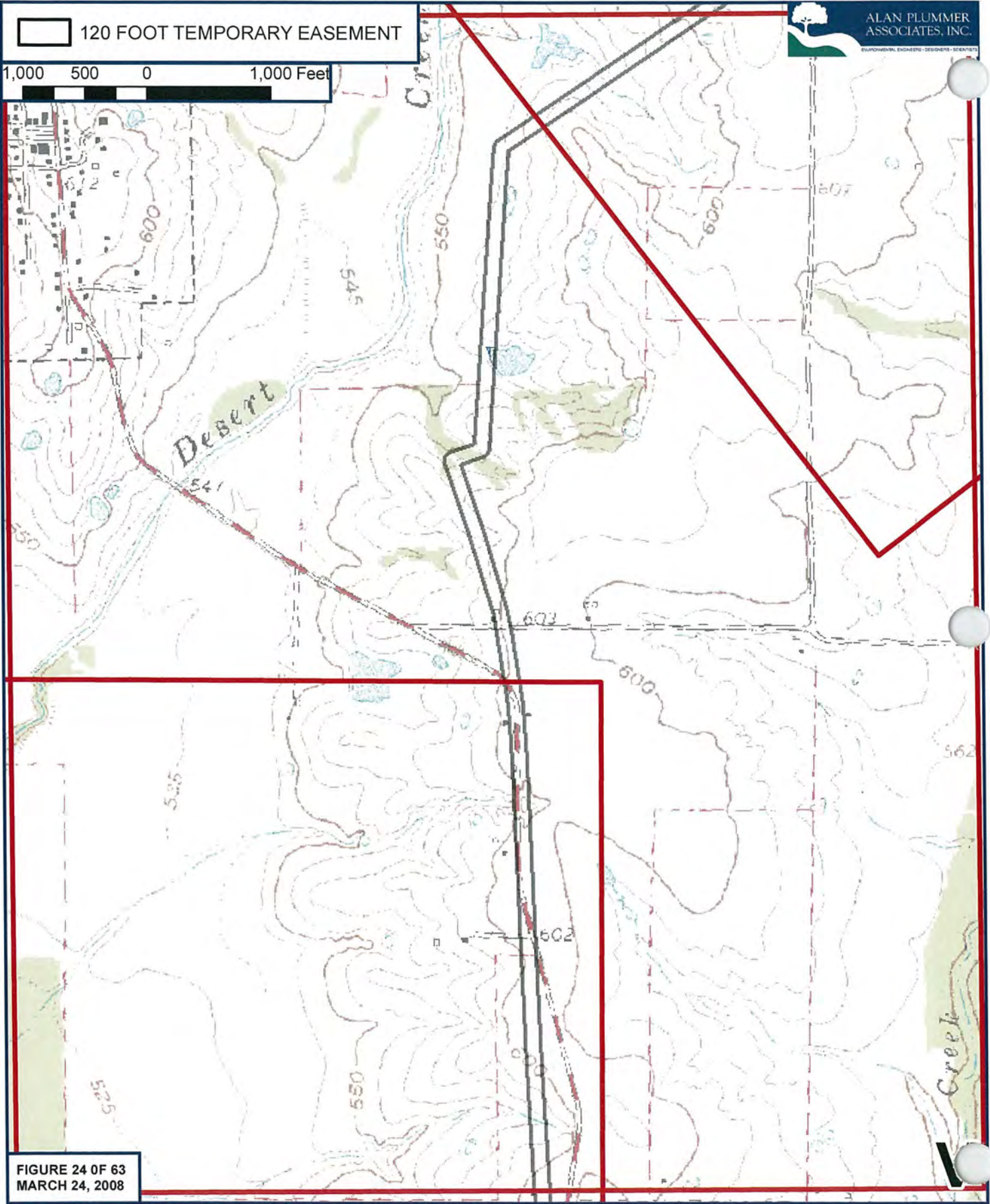

FIGURE 24 OF 63
MARCH 24, 2008

A-24
PJD LIMITS, USGS TOPOGRAPHIC MAP
PROPOSED BOIS D'ARC RESERVOIR - RAW WATER TRANSMISSION PIPELINE

120 FOOT TEMPORARY EASEMENT

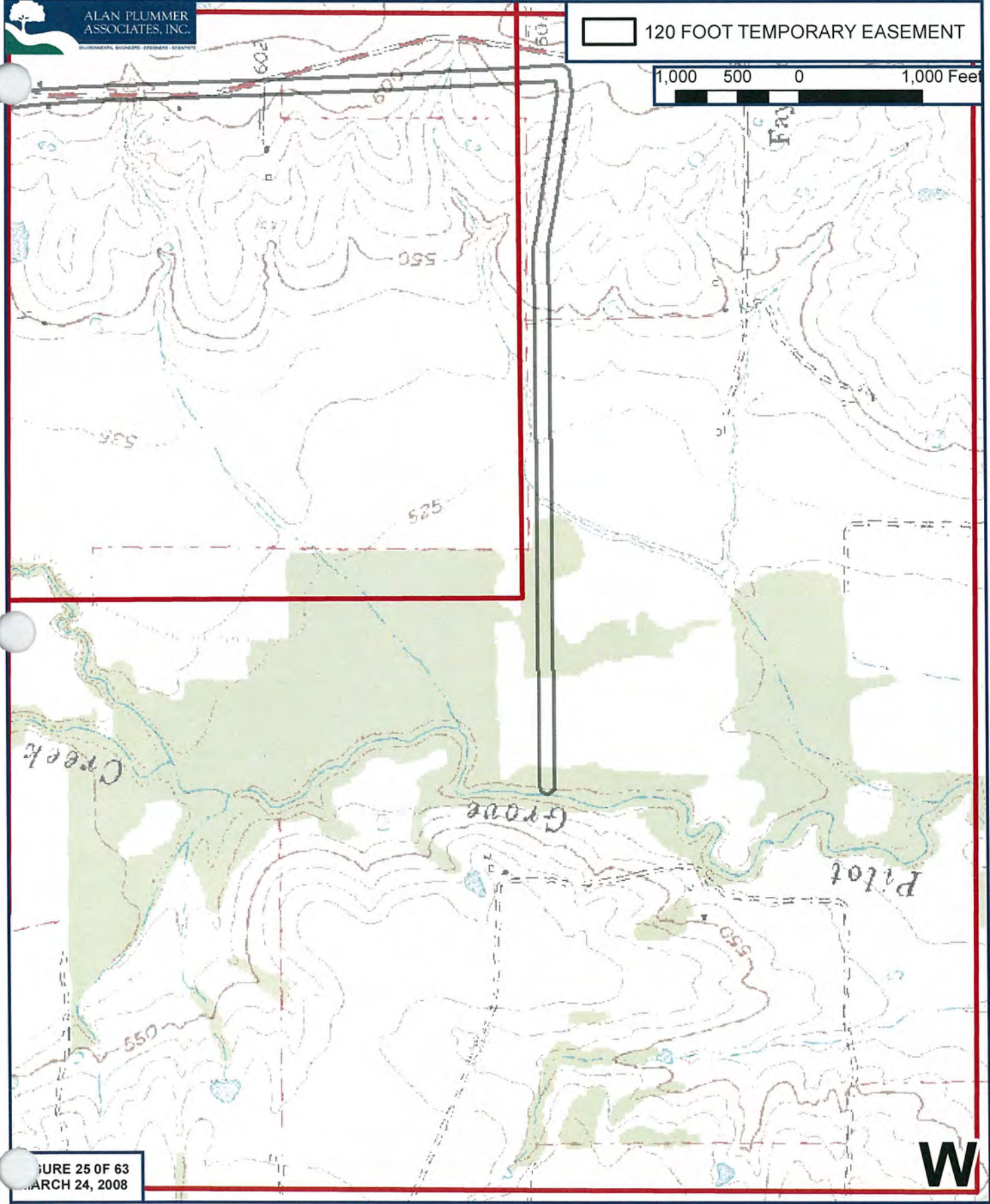
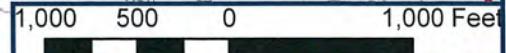
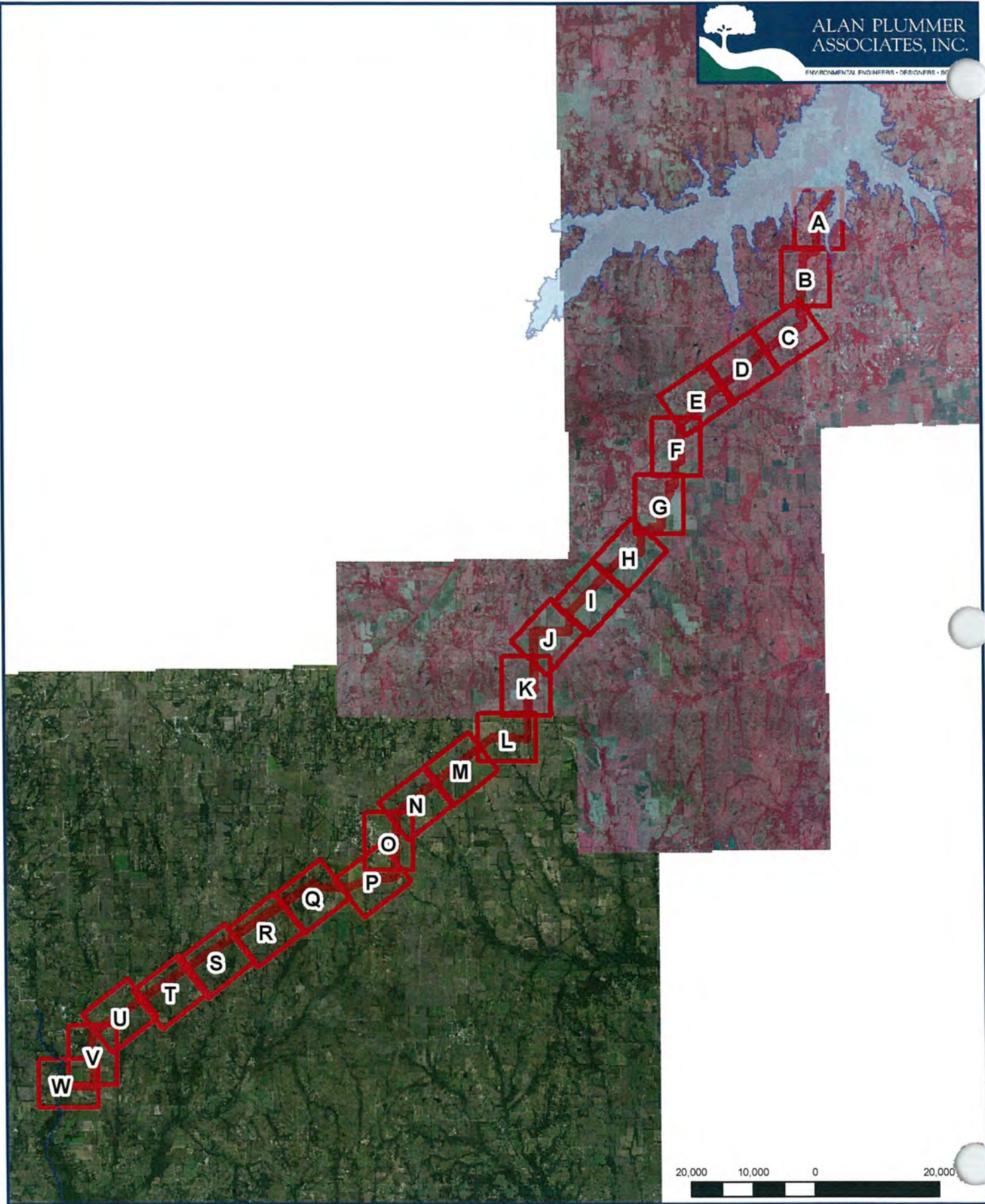

FIGURE 25 OF 63
MARCH 24, 2008

A-25
PJD LIMITS, USGS TOPOGRAPHIC MAP
PROPOSED BOIS D'ARC RESERVOIR - RAW WATER TRANSMISSION PIPELINE



A-26

PJD LIMITS, AERIAL PHOTOGRAPH PLATE LOCATIONS
PROPOSED BOIS D'ARC RESERVOIR - RAW WATER TRANSMISSION PIPELINE ■

FIGURE 26 OF 73
MARCH 25, 2008

120 FOOT TEMPORARY EASEMENT

0 500 0 1,000 Feet



FIGURE 27 OF 73
MARCH 24, 2008

A

A-27
PJD LIMITS, 2004 AERIAL PHOTOGRAPH
PROPOSED BOIS D'ARC RESERVOIR - RAW WATER TRANSMISSION PIPELINE

120 FOOT TEMPORARY EASEMENT

1,000 500 0 1,000 Feet

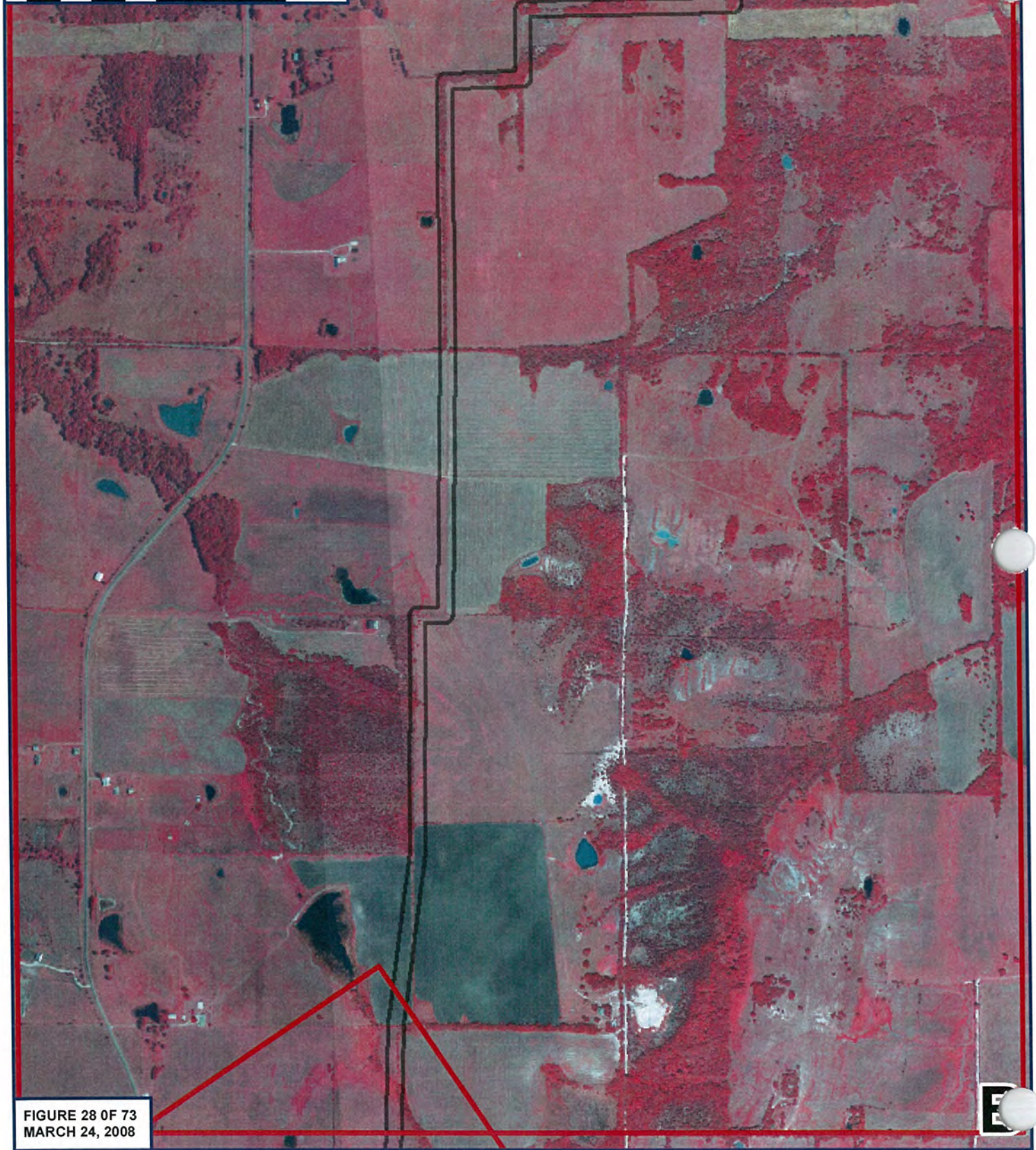

FIGURE 28 OF 73
MARCH 24, 2008

A-28
PJD LIMITS, 2004 AERIAL PHOTOGRAPH
PROPOSED BOIS D'ARC RESERVOIR - RAW WATER TRANSMISSION PIPELINE



120 FOOT TEMPORARY EASEMENT

1,000 500 0 1,000 Feet

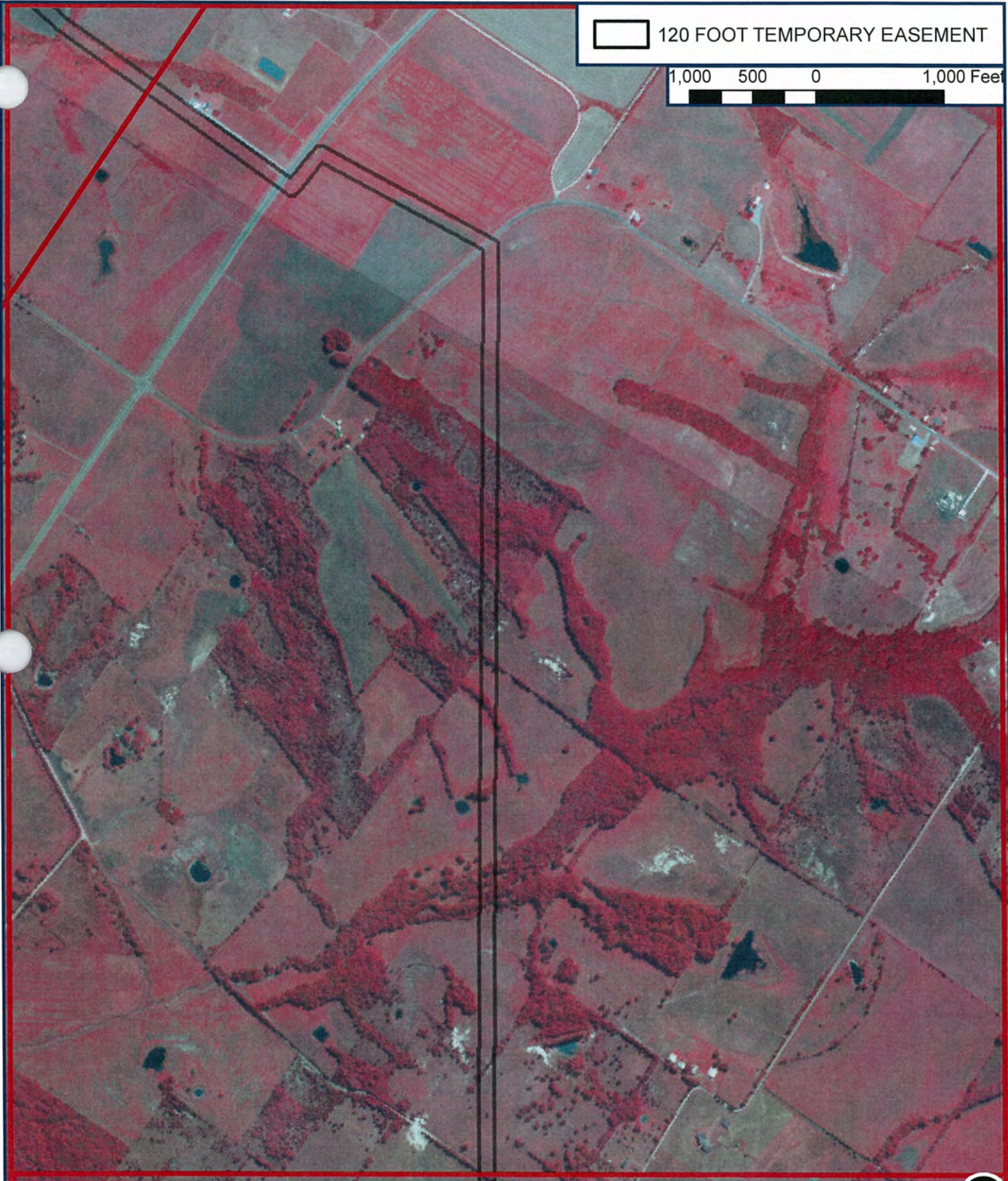

FIGURE 29 OF 73
MARCH 24, 2008



A-29
PJD LIMITS, 2004 AERIAL PHOTOGRAPH
PROPOSED BOIS D'ARC RESERVOIR - RAW WATER TRANSMISSION PIPELINE

120 FOOT TEMPORARY EASEMENT

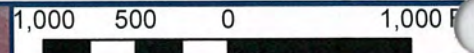

FIGURE 30 OF 73
MARCH 24, 2008

120 FOOT TEMPORARY EASEMENT

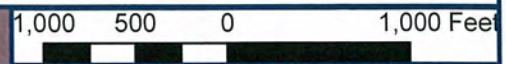

FIGURE 31 OF 73
MARCH 24, 2008

A-31
PJD LIMITS, 2004 AERIAL PHOTOGRAPH
PROPOSED BOIS D'ARC RESERVOIR - RAW WATER TRANSMISSION PIPELINE



ALAN PLUMMER
ASSOCIATES, INC.

ENVIRONMENTAL ENGINEERS - DESIGNERS - SCIENTISTS



120 FOOT TEMPORARY EASEMENT

1,000 500 0 1,000 F

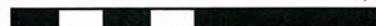

FIGURE 32 OF 73
MARCH 24, 2008

F

A-32

PJD LIMITS, 2004 AERIAL PHOTOGRAPH
PROPOSED BOIS D'ARC RESERVOIR - RAW WATER TRANSMISSION PIPELINE

120 FOOT TEMPORARY EASEMENT

0 500 0 1,000 Feet

FIGURE 33 OF 73
MARCH 24, 2008



A-33
PJD LIMITS, 2004 AERIAL PHOTOGRAPH
PROPOSED BOIS D'ARC RESERVOIR - RAW WATER TRANSMISSION PIPELINE

120 FOOT TEMPORARY EASEMENT

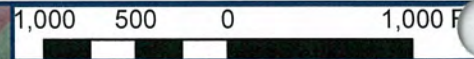

FIGURE 34 OF 73
MARCH 24, 2008



A-34
PJD LIMITS, 2004 AERIAL PHOTOGRAPH
PROPOSED BOIS D'ARC RESERVOIR - RAW WATER TRANSMISSION PIPELINE

120 FOOT TEMPORARY EASEMENT

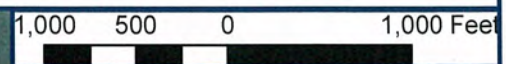

FIGURE 35 OF 73
MARCH 24, 2008

A-35
PJD LIMITS, 2004 AERIAL PHOTOGRAPH
PROPOSED BOIS D'ARC RESERVOIR - RAW WATER TRANSMISSION PIPELINE

120 FOOT TEMPORARY EASEMENT

1,000 500 0 1,000 Feet

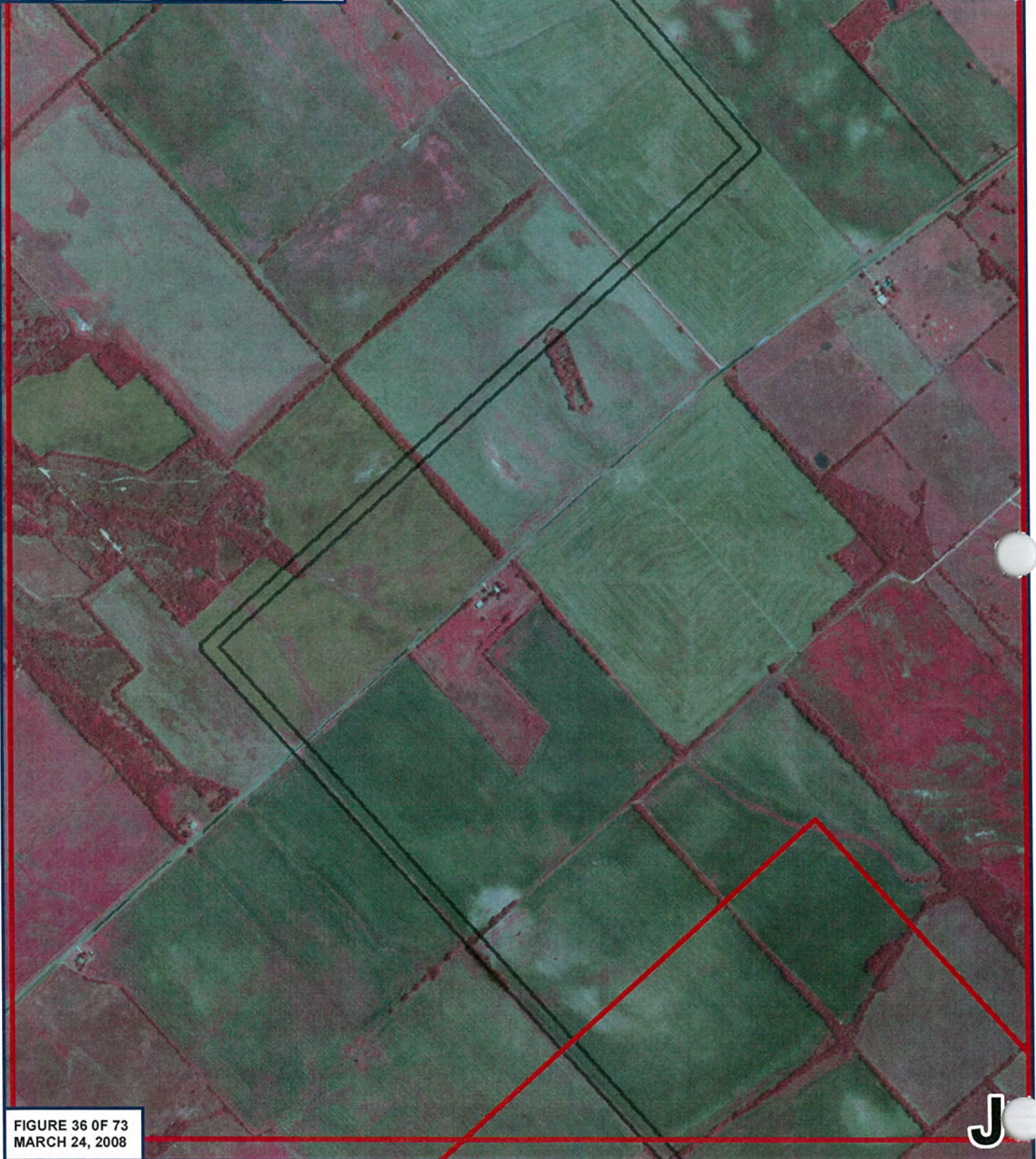

FIGURE 36 OF 73
MARCH 24, 2008

J

A-36
PJD LIMITS, 2004 AERIAL PHOTOGRAPH
PROPOSED BOIS D'ARC RESERVOIR - RAW WATER TRANSMISSION PIPELINE

120 FOOT TEMPORARY EASEMENT

0 500 0 1,000 Feet



FIGURE 37 OF 73
MARCH 24, 2008

A-37
PJD LIMITS, 2004 AERIAL PHOTOGRAPH
PROPOSED BOIS D'ARC RESERVOIR - RAW WATER TRANSMISSION PIPELINE

120 FOOT TEMPORARY EASEMENT

1,000 500 0 1,000 Feet



FIGURE 38 OF 73
MARCH 24, 2008

A-38
PJD LIMITS, 2007 AERIAL PHOTOGRAPH
PROPOSED BOIS D'ARC RESERVOIR - RAW WATER TRANSMISSION PIPELINE

120 FOOT TEMPORARY EASEMENT

1,000 500 0 1,000 Feet



FIGURE 39 OF 73
MARCH 24, 2008

M

A-39
PJD LIMITS, 2007 AERIAL PHOTOGRAPH
PROPOSED BOIS D'ARC RESERVOIR - RAW WATER TRANSMISSION PIPELINE

120 FOOT TEMPORARY EASEMENT



FIGURE 40 OF 73
MARCH 24, 2008



A-40
PJD LIMITS, 2007 AERIAL PHOTOGRAPH
PROPOSED BOIS D'ARC RESERVOIR - RAW WATER TRANSMISSION PIPELINE

120 FOOT TEMPORARY EASEMENT

1,000 500 0 1,000 Feet

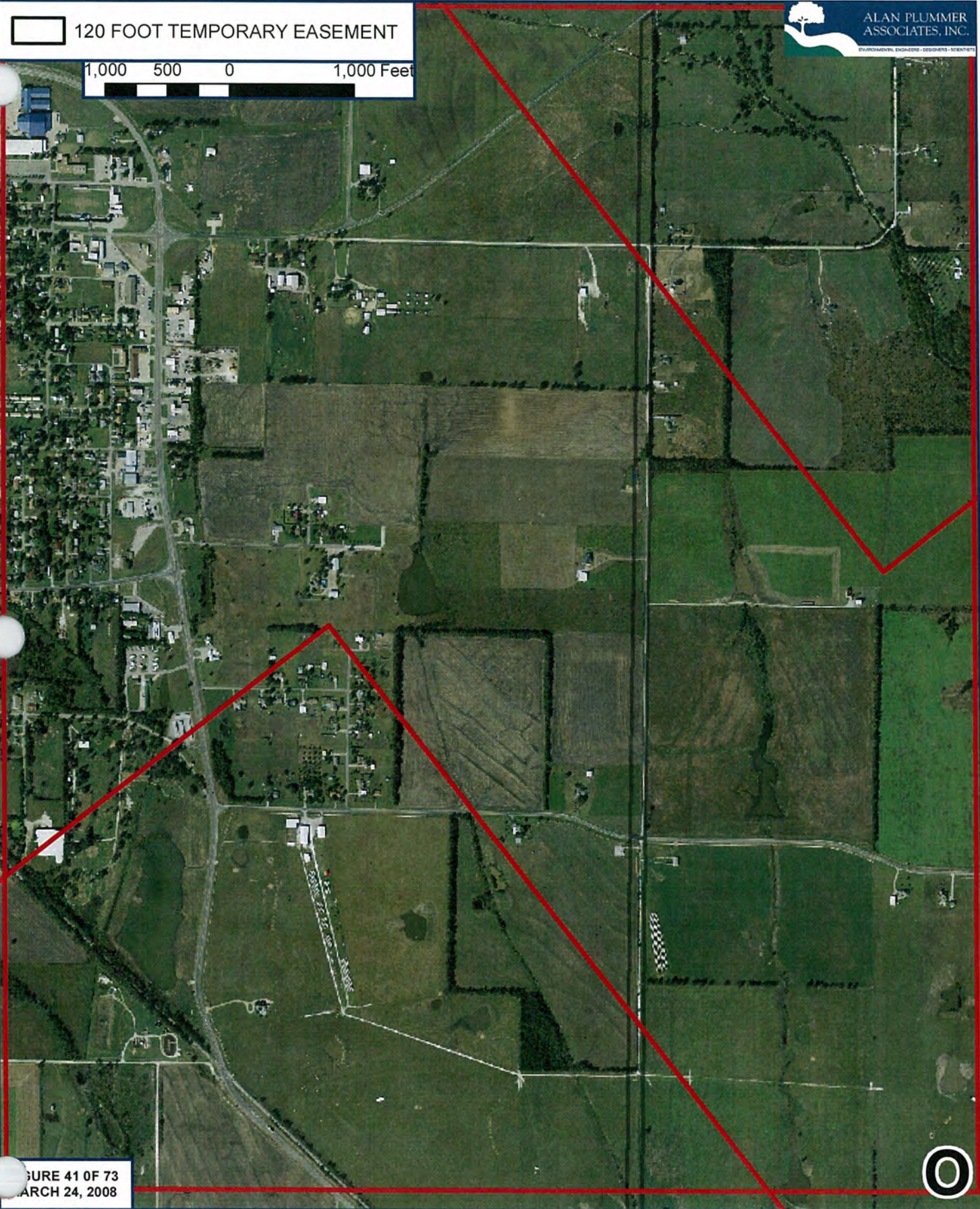

FIGURE 41 OF 73
MARCH 24, 2008



A-41
PJD LIMITS, 2007 AERIAL PHOTOGRAPH
PROPOSED BOIS D'ARC RESERVOIR - RAW WATER TRANSMISSION PIPELINE

120 FOOT TEMPORARY EASEMENT

1,000 500 0 1,000 Feet



FIGURE 42 OF 73
MARCH 24, 2008

A-42
PJD LIMITS, 2007 AERIAL PHOTOGRAPH
PROPOSED BOIS D'ARC RESERVOIR - RAW WATER TRANSMISSION PIPELINE

120 FOOT TEMPORARY EASEMENT

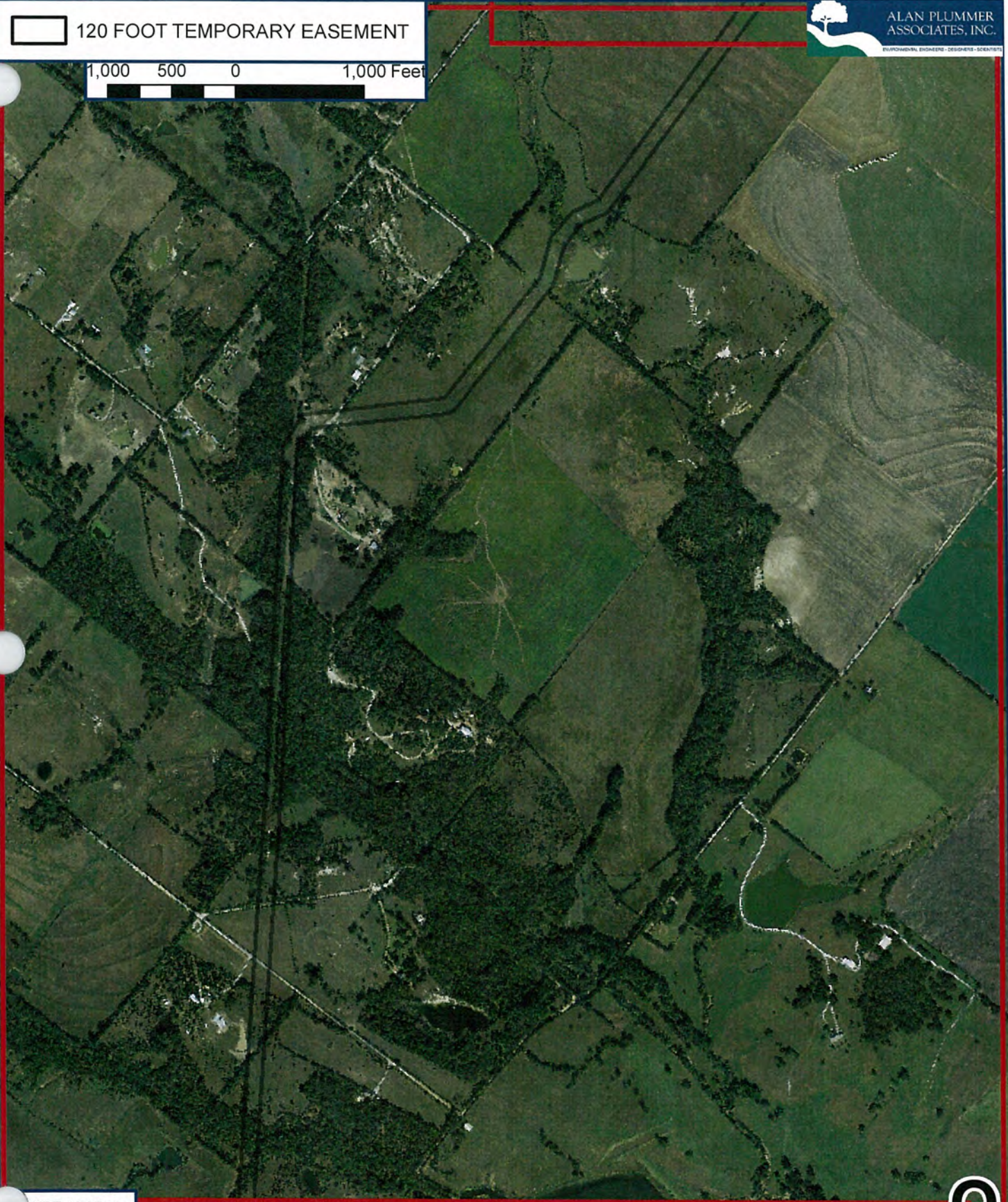
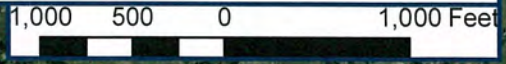

FIGURE 43 OF 73
MARCH 24, 2008



A-43
PJD LIMITS, 2007 AERIAL PHOTOGRAPH
PROPOSED BOIS D'ARC RESERVOIR - RAW WATER TRANSMISSION PIPELINE

120 FOOT TEMPORARY EASEMENT

1,000 500 0 1,000 Feet

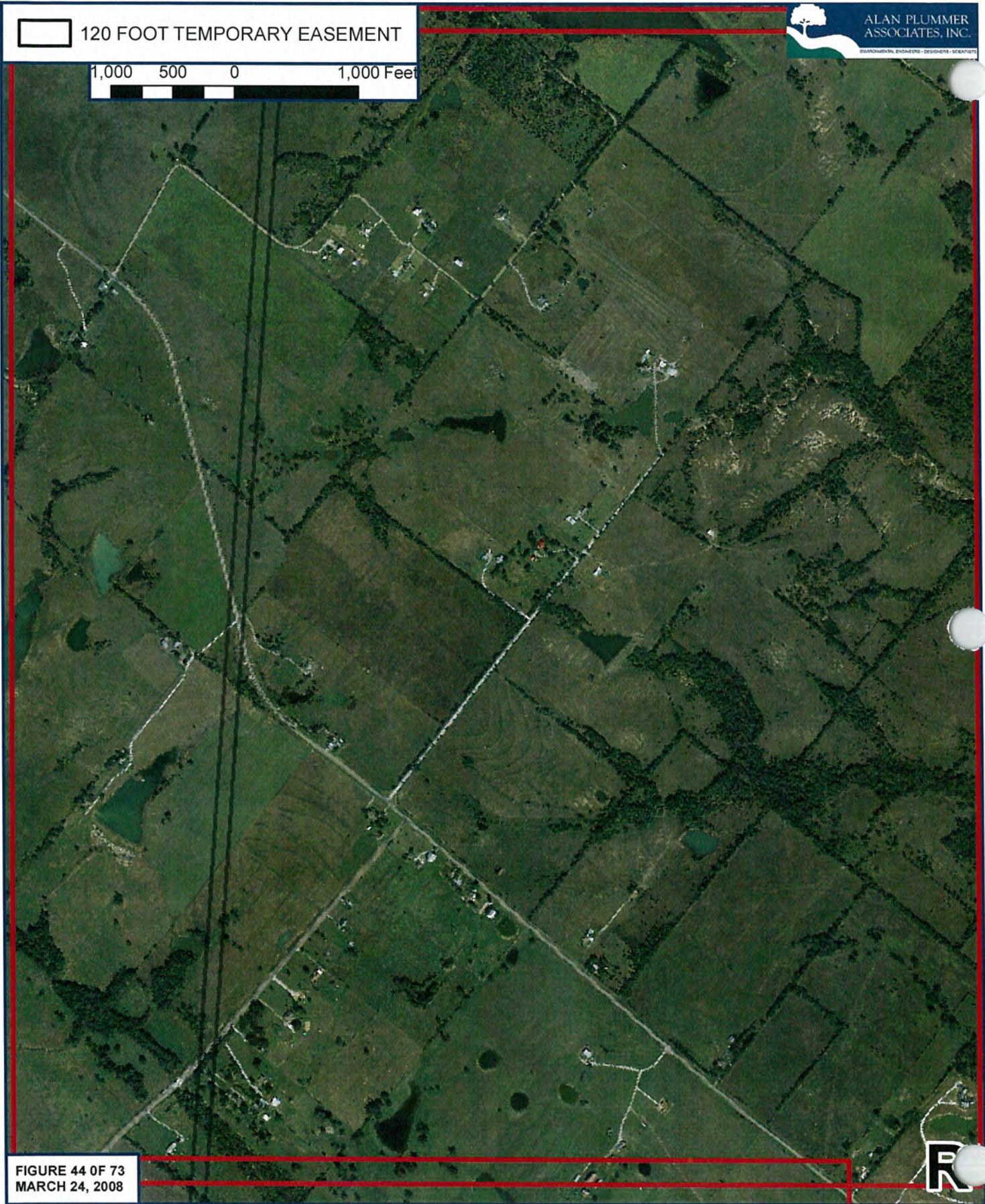

FIGURE 44 OF 73
MARCH 24, 2008

A-44
PJD LIMITS, 2007 AERIAL PHOTOGRAPH
PROPOSED BOIS D'ARC RESERVOIR - RAW WATER TRANSMISSION PIPELINE

120 FOOT TEMPORARY EASEMENT

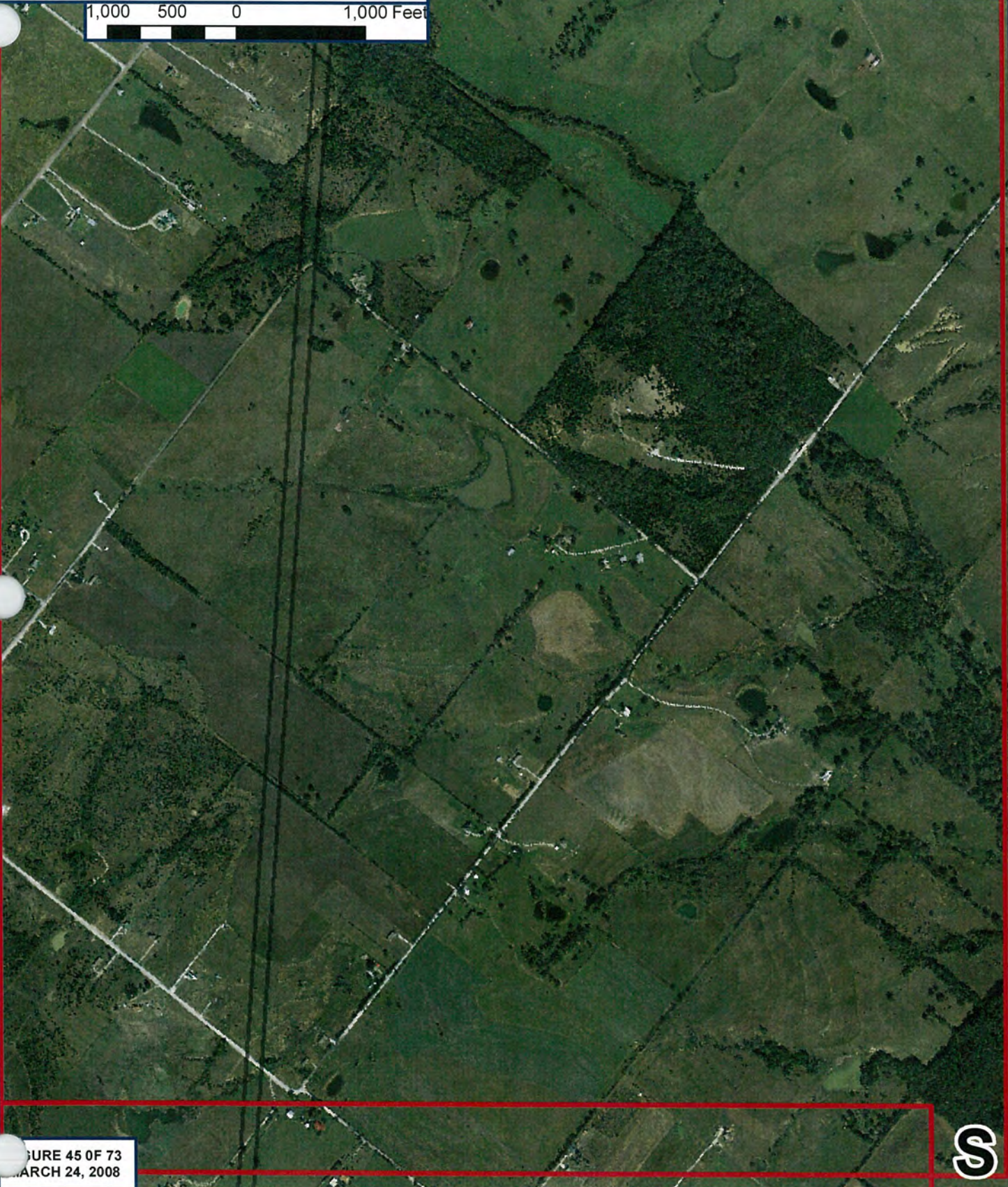
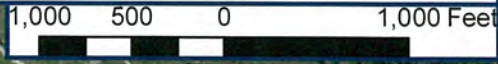

FIGURE 45 OF 73
MARCH 24, 2008



A-45
PJD LIMITS, 2007 AERIAL PHOTOGRAPH
PROPOSED BOIS D'ARC RESERVOIR - RAW WATER TRANSMISSION PIPELINE

120 FOOT TEMPORARY EASEMENT

1,000 500 0 1,000 F

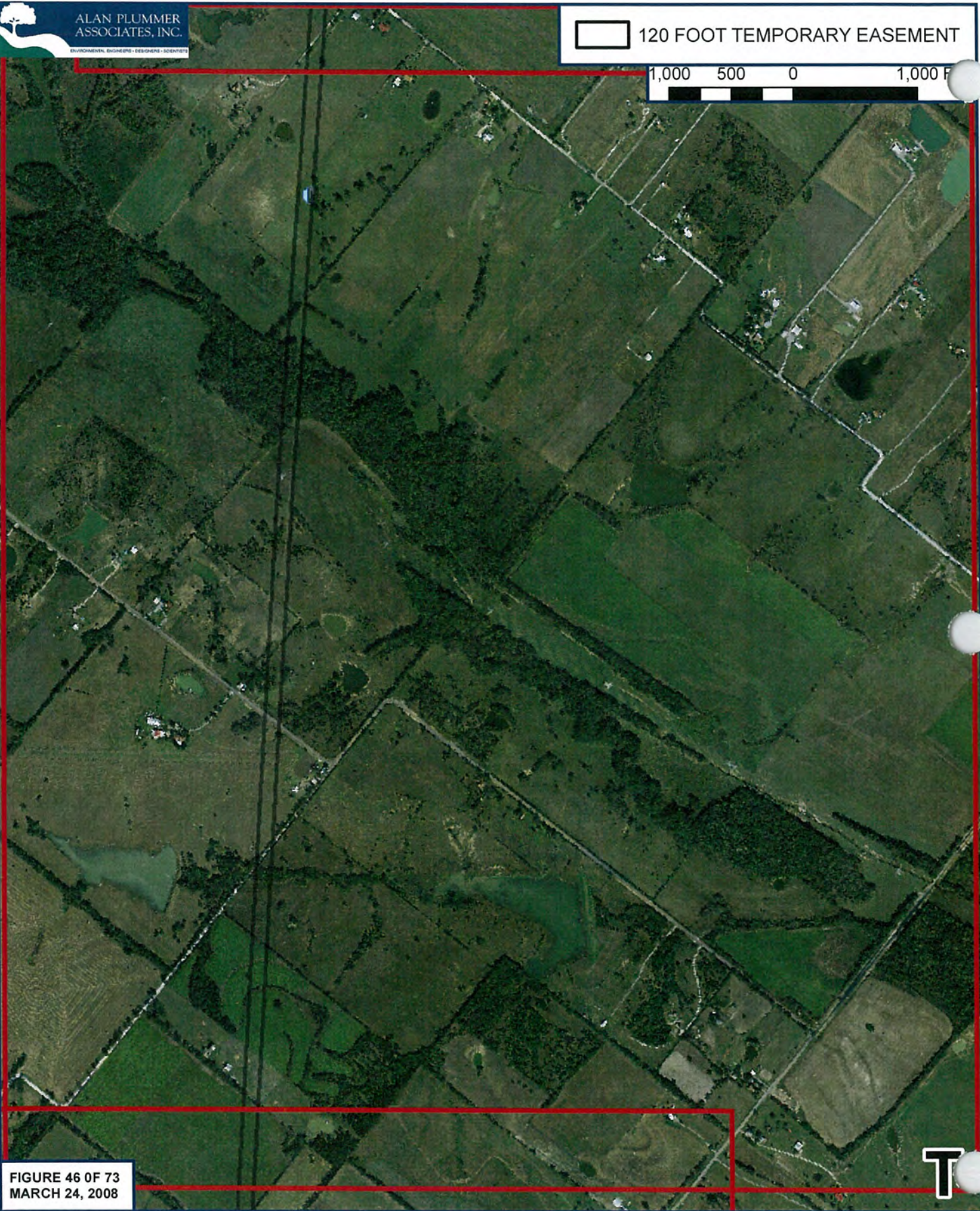

FIGURE 46 OF 73
MARCH 24, 2008

T

A-46
PJD LIMITS, 2007 AERIAL PHOTOGRAPH
PROPOSED BOIS D'ARC RESERVOIR - RAW WATER TRANSMISSION PIPELINE

120 FOOT TEMPORARY EASEMENT

1,000 500 0 1,000 Feet



FIGURE 47 OF 73
MARCH 24, 2008

U

A-47
PJD LIMITS, 2007 AERIAL PHOTOGRAPH
PROPOSED BOIS D'ARC RESERVOIR - RAW WATER TRANSMISSION PIPELINE

120 FOOT TEMPORARY EASEMENT

1,000 500 0 1,000 Feet

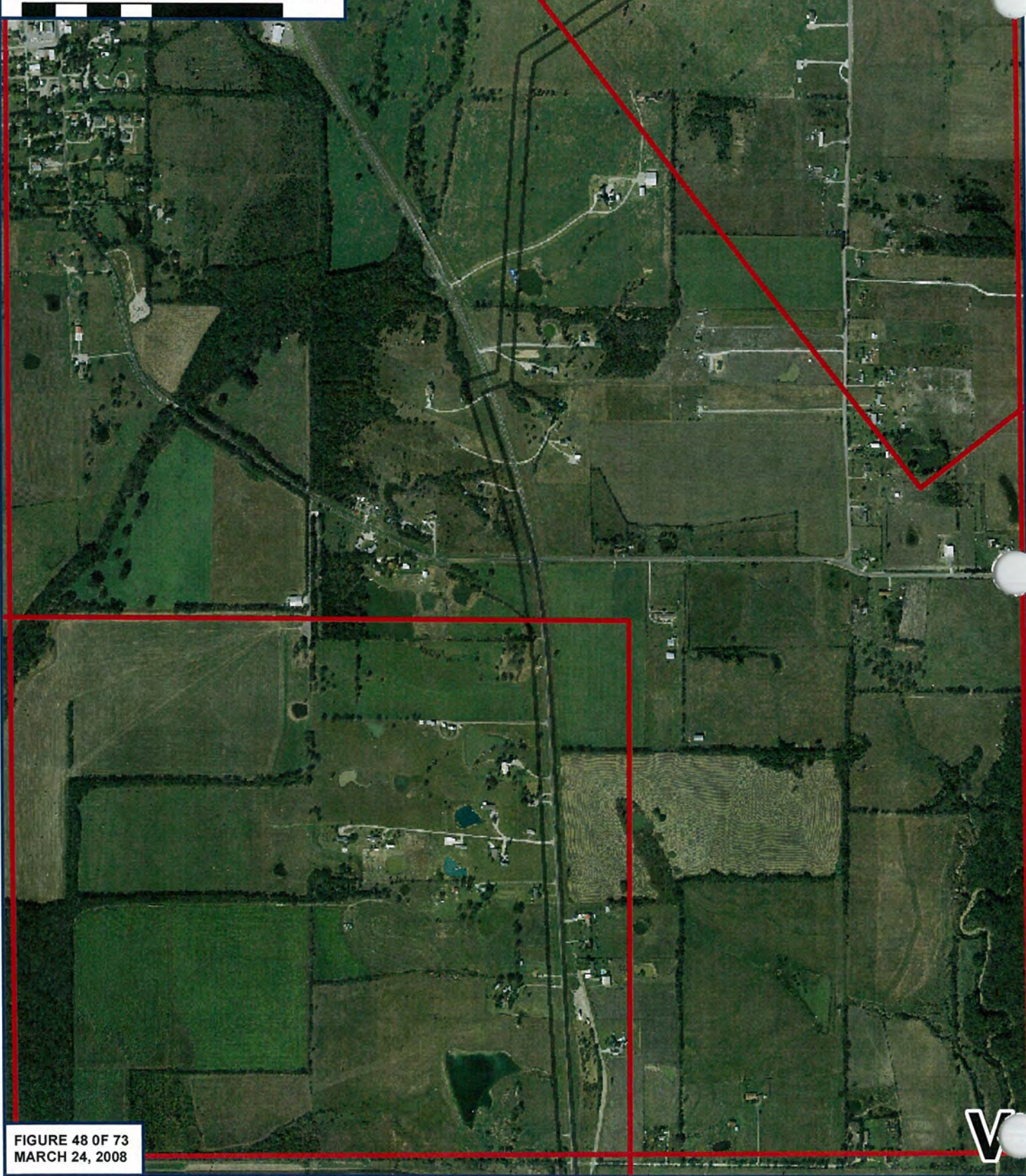

FIGURE 48 OF 73
MARCH 24, 2008

A-48
PJD LIMITS, 2007 AERIAL PHOTOGRAPH
PROPOSED BOIS D'ARC RESERVOIR - RAW WATER TRANSMISSION PIPELINE

120 FOOT TEMPORARY EASEMENT

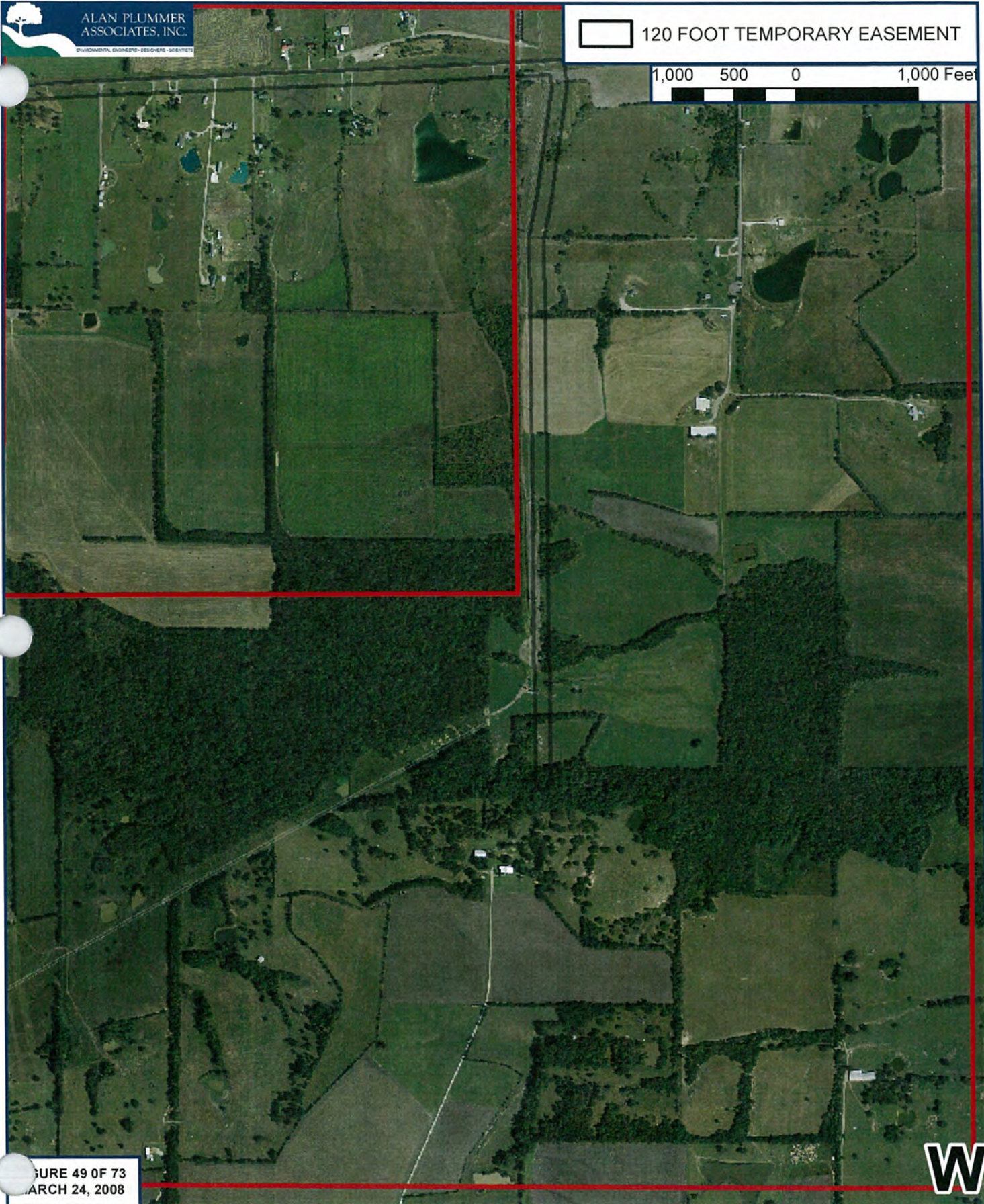
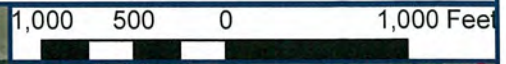
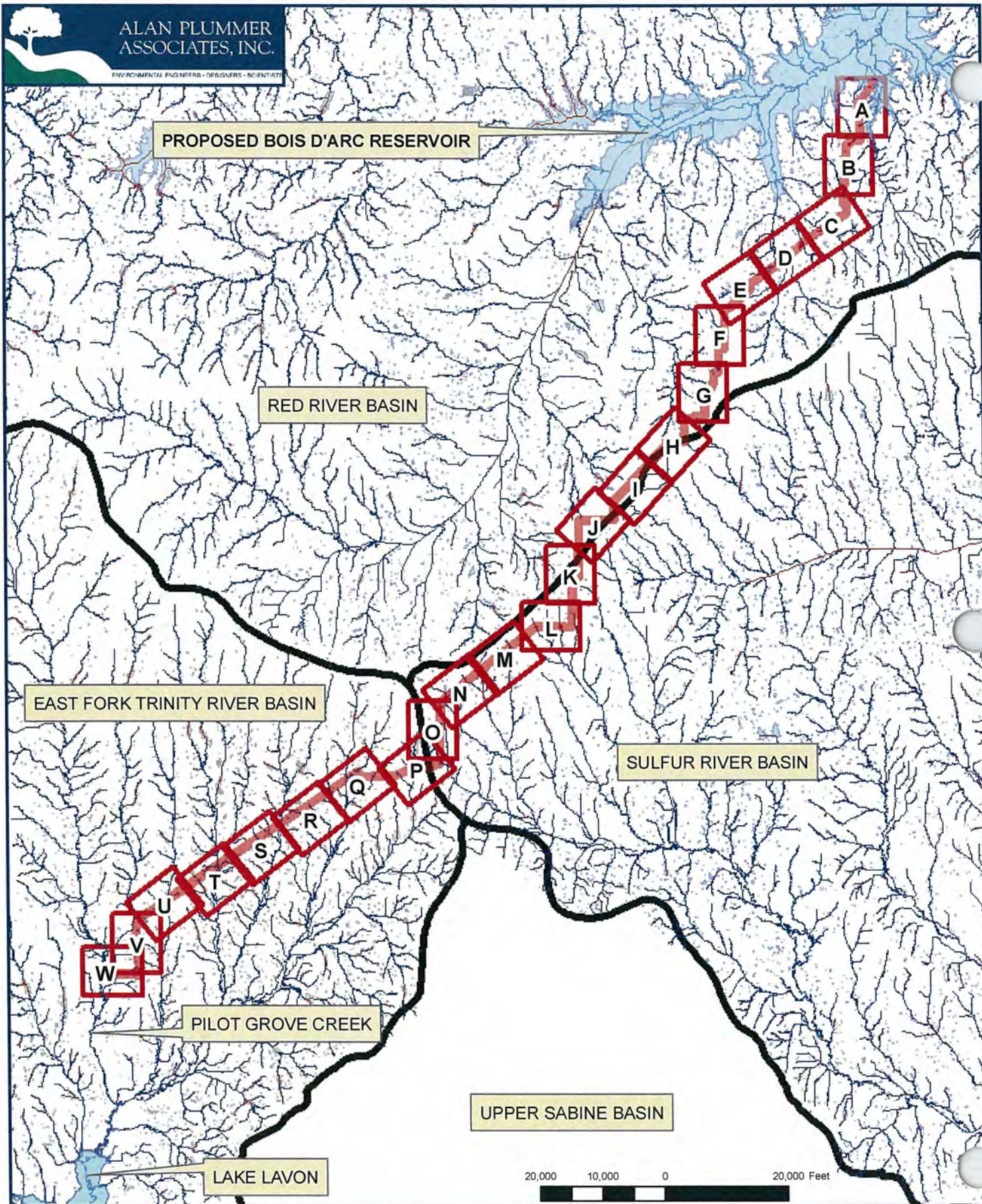

FIGURE 49 OF 73
MARCH 24, 2008

A-49

PJD LIMITS, 2007 AERIAL PHOTOGRAPH
PROPOSED BOIS D'ARC RESERVOIR - RAW WATER TRANSMISSION PIPELINE



A-50

PJD RESULTS PLATE LOCATIONS

FIGURE 50 OF 73
 MARCH 25, 2008

PROPOSED BOIS D'ARC RESERVOIR - RAW WATER TRANSMISSION PIPELINE ■

- Streams 120 FOOT EASEMENT
- Pond 120 FOOT EASEMENT
- Potential Wetlands 120 FOOT EASEMENT
- 120 FOOT TEMPORARY EASEMENT

1,000 500 0 1,000 Feet



FIGURE 51 OF 63
MARCH 24, 2008

A-51
PJD RESULTS
PROPOSED BOIS D'ARC RESERVOIR - RAW WATER TRANSMISSION PIPELINE

- Streams 120 FOOT EASEMENT
- Pond 120 FOOT EASEMENT
- Potential Wetlands 120 FOOT EASEMENT
- 120 FOOT TEMPORARY EASEMENT

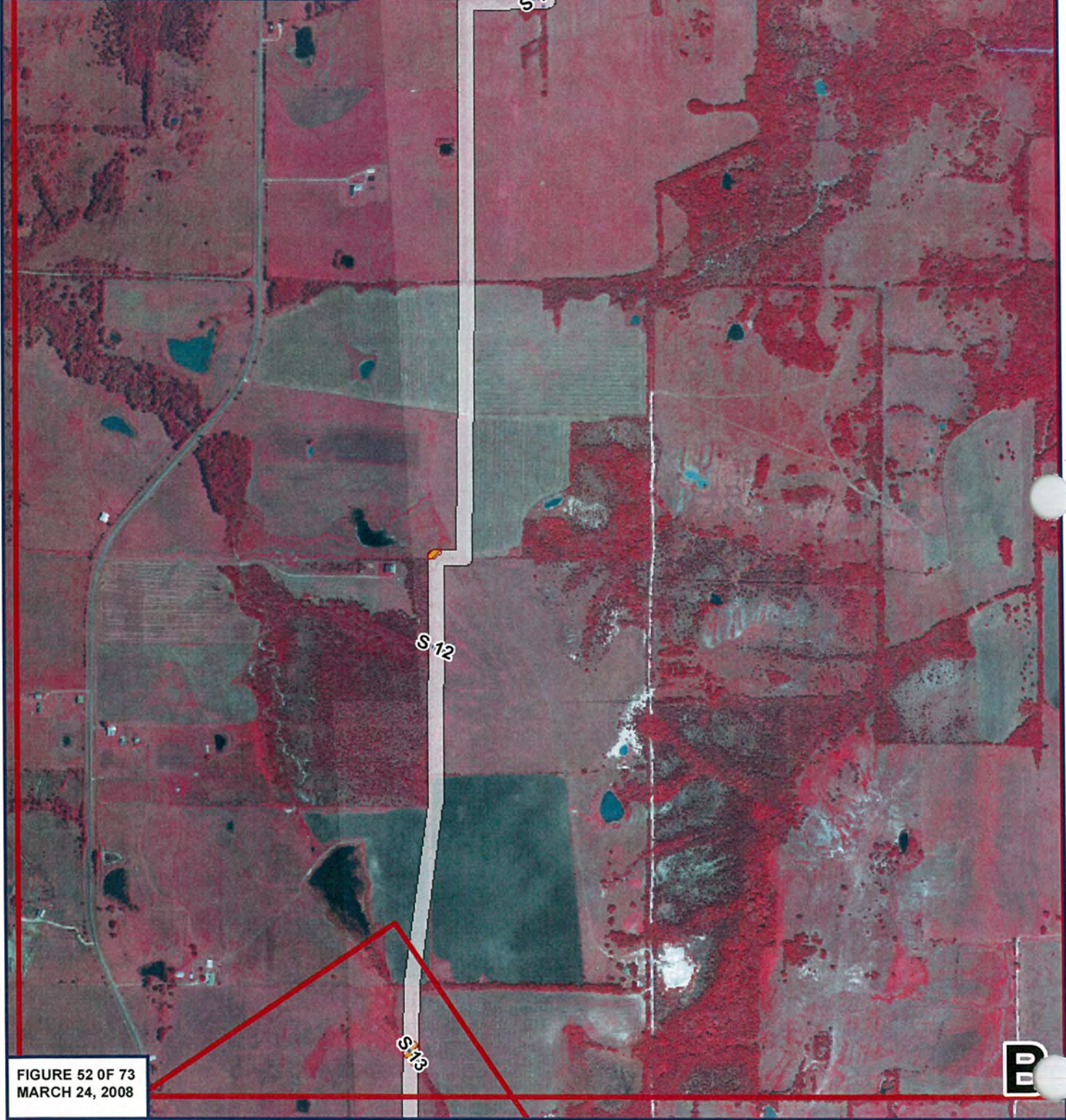



FIGURE 52 OF 73
MARCH 24, 2008



A-52
PJD RESULTS
PROPOSED BOIS D'ARC RESERVOIR - RAW WATER TRANSMISSION PIPELINE



-  Streams 120 FOOT EASEMENT
-  Pond 120 FOOT EASEMENT
-  Potential Wetlands 120 FOOT EASEMENT
-  120 FOOT TEMPORARY EASEMENT

1,000 500 0 1,000 Feet

ALAN PLUMMER ASSOCIATES, INC.
ENVIRONMENTAL ENGINEERS • DESIGNERS • SCIENTISTS

FIGURE 53 OF 73
 MARCH 24, 2008



A-53
PJD RESULTS
PROPOSED BOIS D'ARC RESERVOIR - RAW WATER TRANSMISSION PIPELINE

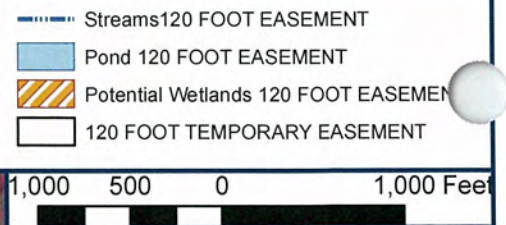

FIGURE 54 OF 73
MARCH 24, 2008



A-54
PJD RESULTS
PROPOSED BOIS D'ARC RESERVOIR - RAW WATER TRANSMISSION PIPELINE

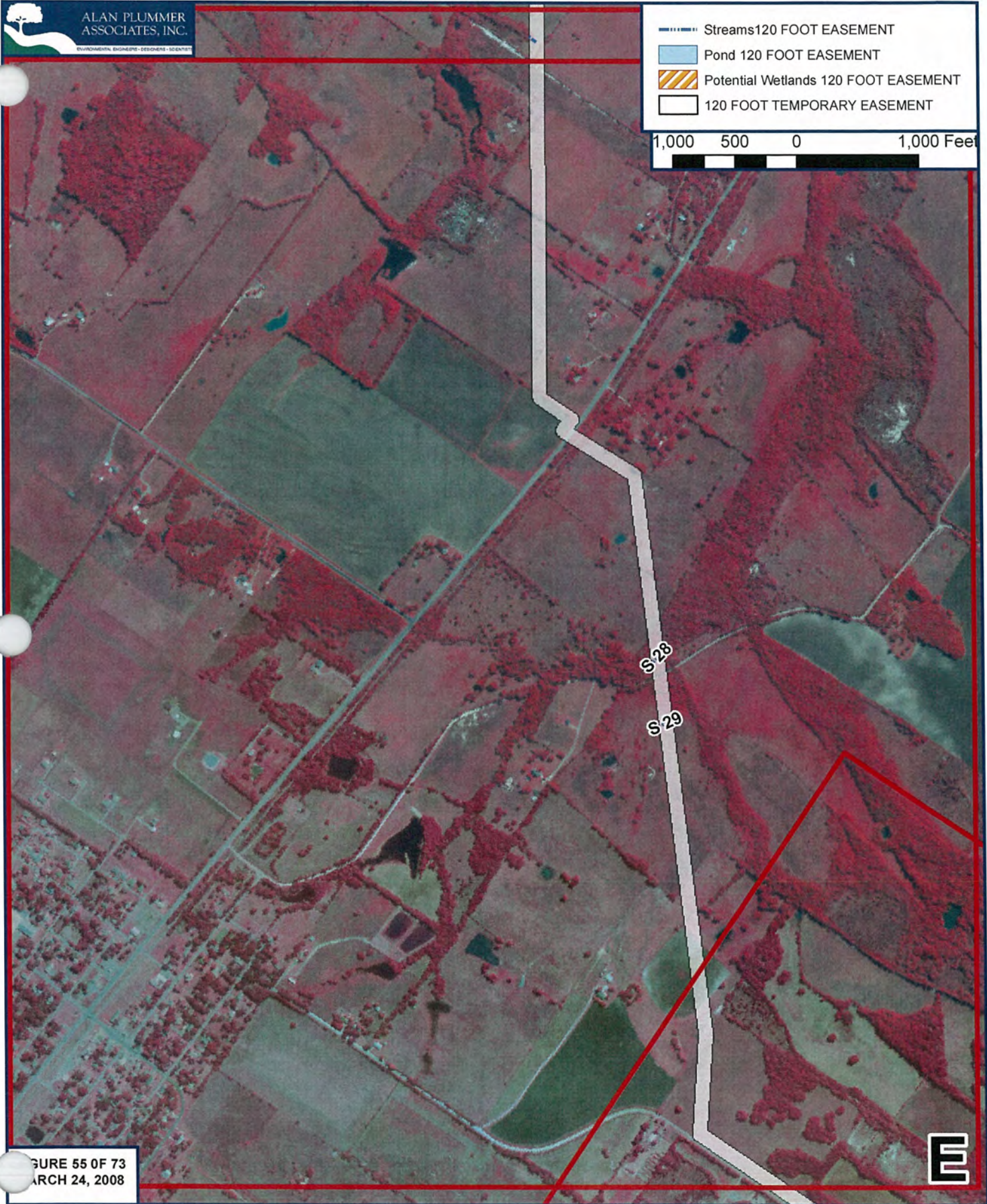
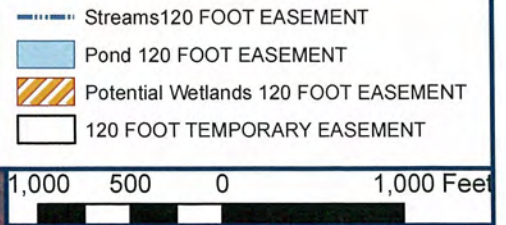

FIGURE 55 OF 73
MARCH 24, 2008



A-55
PJD RESULTS
PROPOSED BOIS D'ARC RESERVOIR - RAW WATER TRANSMISSION PIPELINE

- Streams 120 FOOT EASEMENT
- Pond 120 FOOT EASEMENT
- Potential Wetlands 120 FOOT EASEMENT
- 120 FOOT TEMPORARY EASEMENT

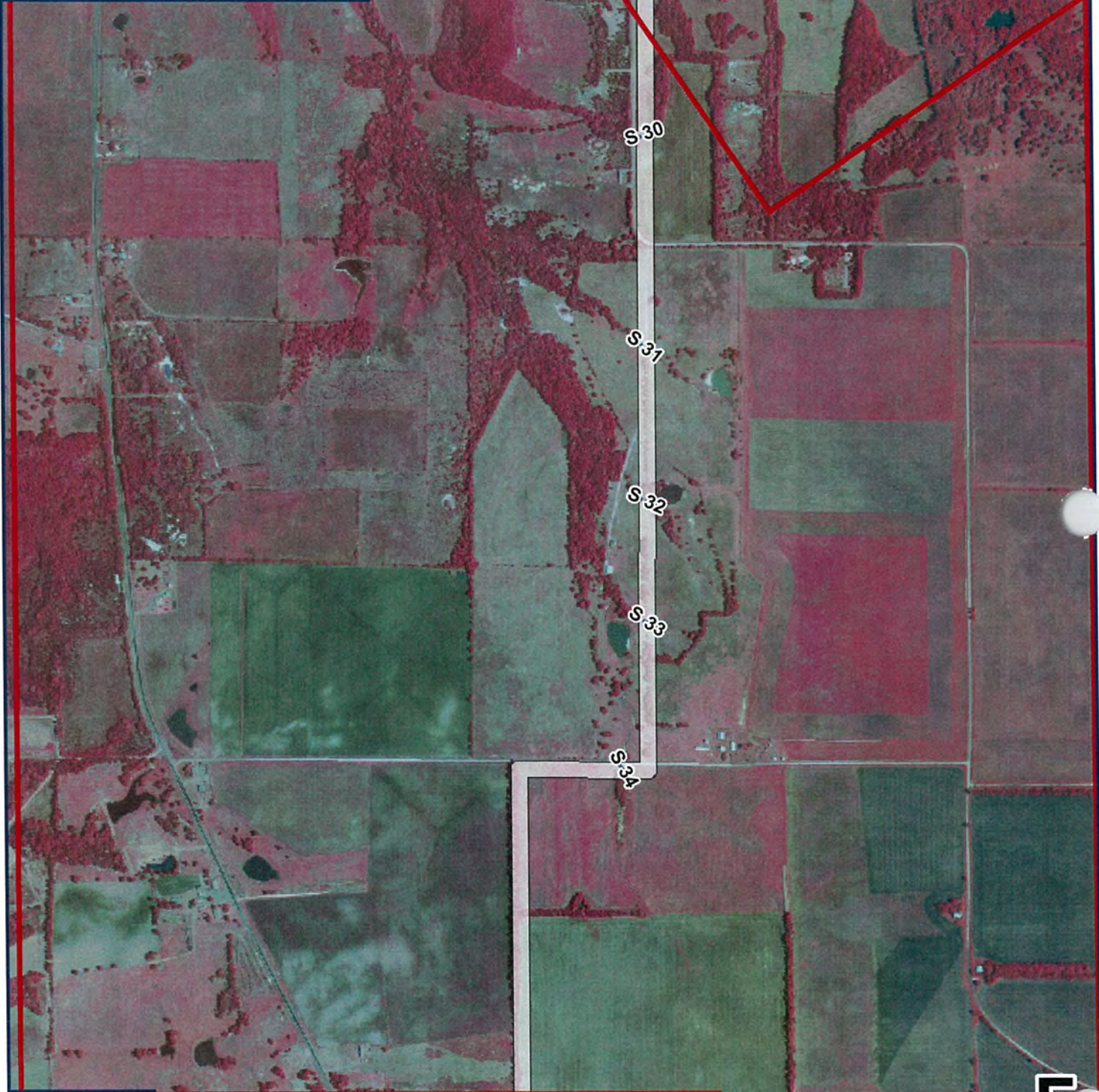
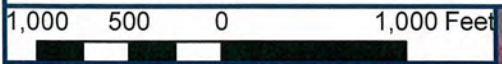

FIGURE 56 OF 73
MARCH 24, 2008

F

A-56
PJD RESULTS
PROPOSED BOIS D'ARC RESERVOIR - RAW WATER TRANSMISSION PIPELINE



A-57
PJD RESULTS
PROPOSED BOIS D'ARC RESERVOIR - RAW WATER TRANSMISSION PIPELINE

Streams 120 FOOT EASEMENT
Pond 120 FOOT EASEMENT
Potential Wetlands 120 FOOT EASEMENT
120 FOOT TEMPORARY EASEMENT

1,000 500 0 1,000 Feet



FIGURE 58 OF 73
MARCH 24, 2008

S 338



A-58
PJD RESULTS
PROPOSED BOIS D'ARC RESERVOIR - RAW WATER TRANSMISSION PIPELINE

Streams 120 FOOT EASEMENT
Pond 120 FOOT EASEMENT
Potential Wetlands 120 FOOT EASEMENT
120 FOOT TEMPORARY EASEMENT

1,000 500 0 1,000 Feet



FIGURE 59 OF 73
MARCH 24, 2008

A-59
PJD RESULTS
PROPOSED BOIS D'ARC RESERVOIR - RAW WATER TRANSMISSION PIPELINE

- Streams 120 FOOT EASEMENT
- Pond 120 FOOT EASEMENT
- Potential Wetlands 120 FOOT EASEMENT
- 120 FOOT TEMPORARY EASEMENT

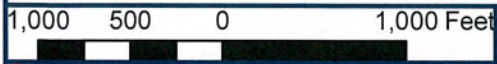

FIGURE 60 OF 73
MARCH 24, 2008

J

A-60
PJD RESULTS
PROPOSED BOIS D'ARC RESERVOIR - RAW WATER TRANSMISSION PIPELINE

- Streams 120 FOOT EASEMENT
- Pond 120 FOOT EASEMENT
- Potential Wetlands 120 FOOT EASEMENT
- 120 FOOT TEMPORARY EASEMENT

1,000 500 0 1,000 Feet

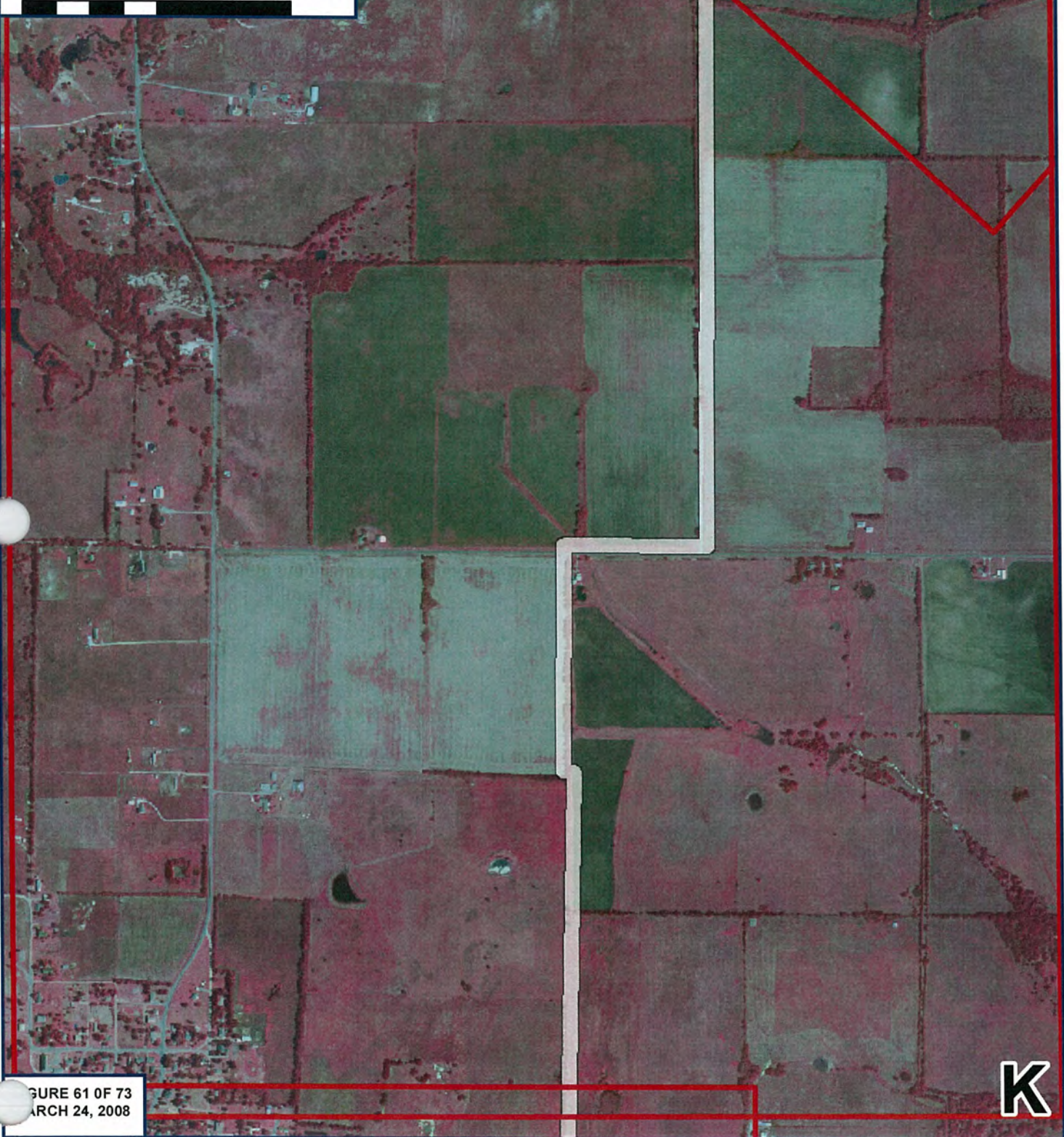

FIGURE 61 OF 73
MARCH 24, 2008

K

A-61
PJD RESULTS
PROPOSED BOIS D'ARC RESERVOIR - RAW WATER TRANSMISSION PIPELINE

Streams 120 FOOT EASEMENT
Pond 120 FOOT EASEMENT
Potential Wetlands 120 FOOT EASEMENT
120 FOOT TEMPORARY EASEMENT

1,000 500 0 1,000 Feet



FIGURE 62 OF 73
MARCH 24, 2008

A-62
PJD RESULTS
PROPOSED BOIS D'ARC RESERVOIR - RAW WATER TRANSMISSION PIPELINE

- Streams 120 FOOT EASEMENT
- Pond 120 FOOT EASEMENT
- Potential Wetlands 120 FOOT EASEMENT
- 120 FOOT TEMPORARY EASEMENT

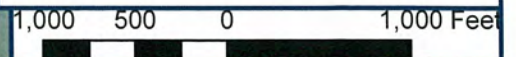

FIGURE 63 OF 73
MARCH 24, 2008



A-63
PJD RESULTS
PROPOSED BOIS D'ARC RESERVOIR - RAW WATER TRANSMISSION PIPELINE

Streams 120 FOOT EASEMENT
Pond 120 FOOT EASEMENT
Potential Wetlands 120 FOOT EASEMENT
120 FOOT TEMPORARY EASEMENT

1,000 500 0 1,000 Feet

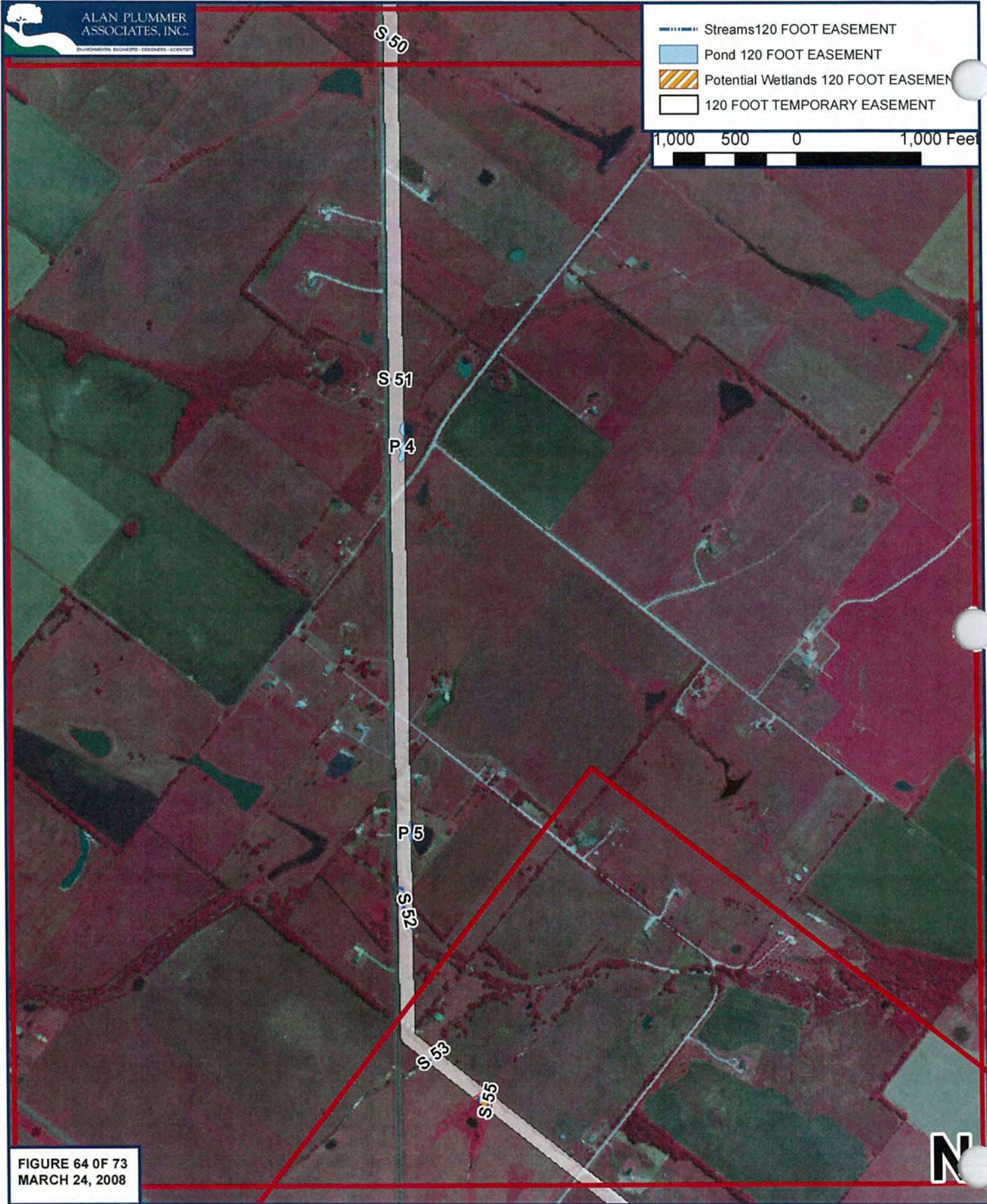

FIGURE 64 OF 73
MARCH 24, 2008

A-64
PJD RESULTS
PROPOSED BOIS D'ARC RESERVOIR - RAW WATER TRANSMISSION PIPELINE

Streams 120 FOOT EASEMENT
Pond 120 FOOT EASEMENT
Potential Wetlands 120 FOOT EASEMENT
120 FOOT TEMPORARY EASEMENT

1,000 500 0 1,000 Feet

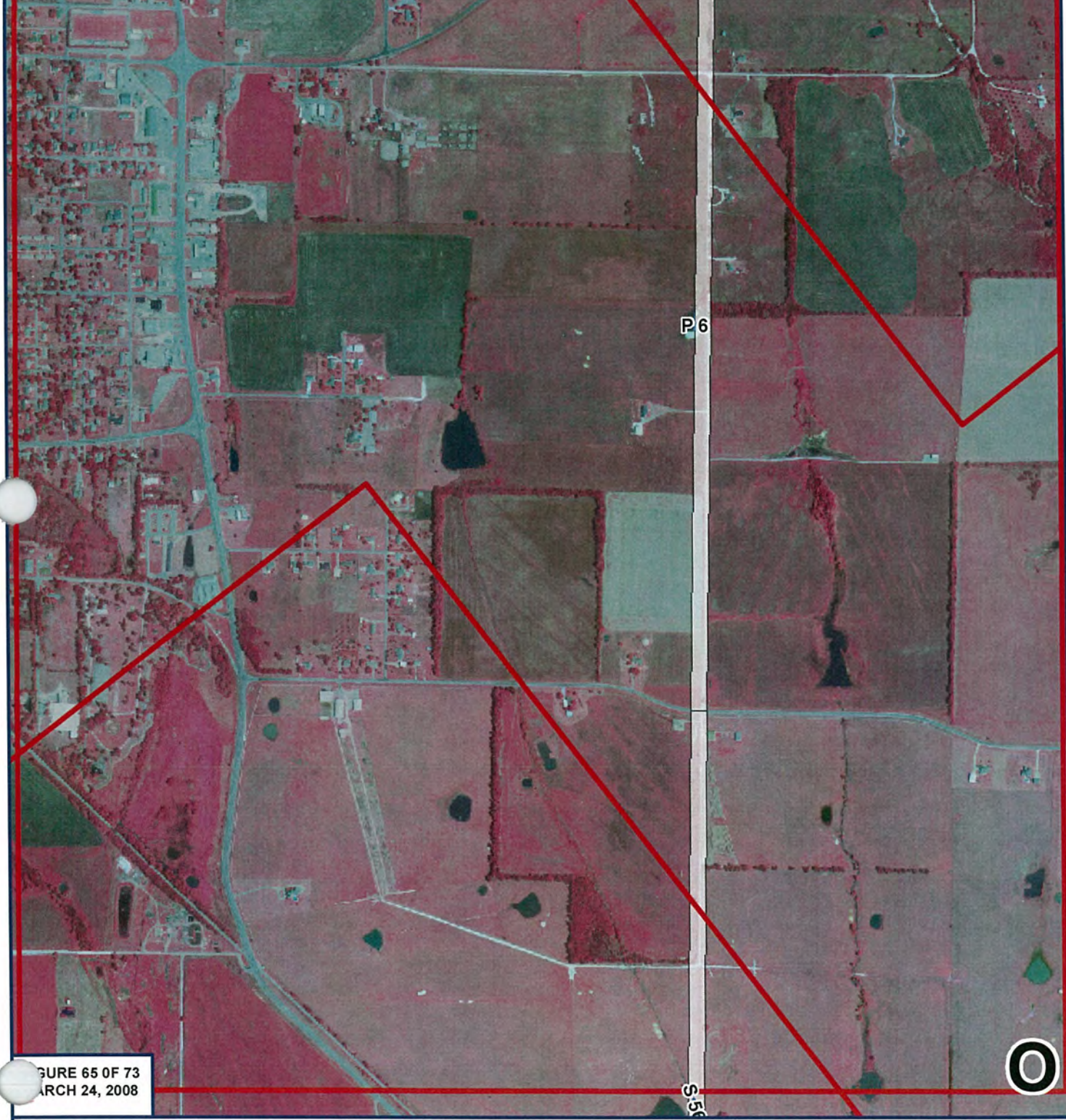

FIGURE 65 OF 73
MARCH 24, 2008



A-65
PJD RESULTS
PROPOSED BOIS D'ARC RESERVOIR - RAW WATER TRANSMISSION PIPELINE

- Streams 120 FOOT EASEMENT
- Pond 120 FOOT EASEMENT
- Potential Wetlands 120 FOOT EASEMENT
- 120 FOOT TEMPORARY EASEMENT

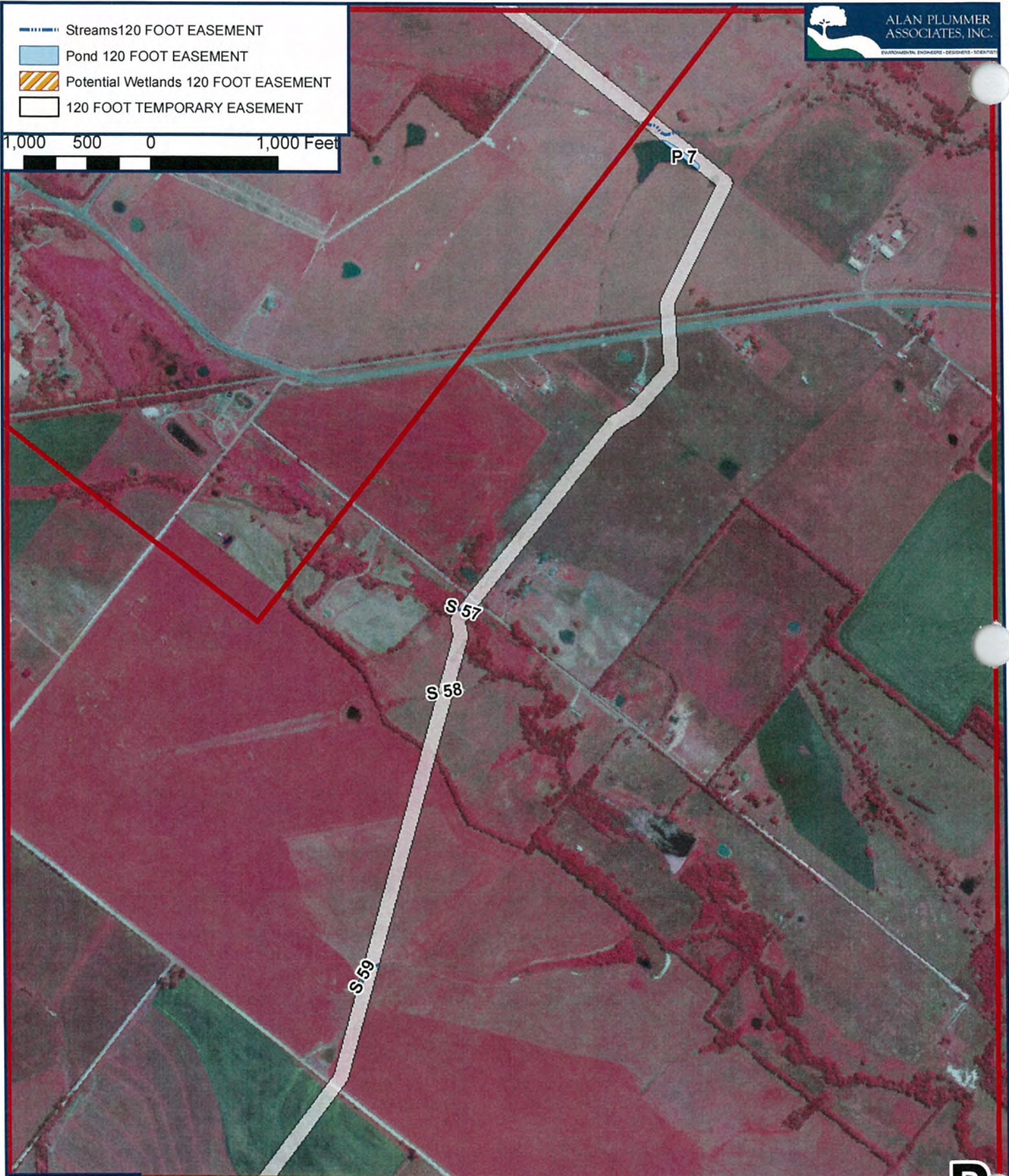
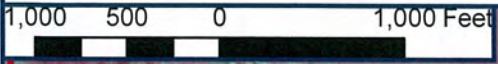

FIGURE 66 OF 73
MARCH 24, 2008

P

A-66
PJD RESULTS
PROPOSED BOIS D'ARC RESERVOIR - RAW WATER TRANSMISSION PIPELINE

- Streams 120 FOOT EASEMENT
- Pond 120 FOOT EASEMENT
- Potential Wetlands 120 FOOT EASEMENT
- 120 FOOT TEMPORARY EASEMENT

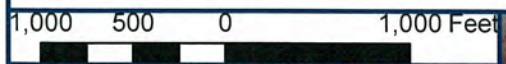

FIGURE 67 OF 73
MARCH 24, 2008

A-67
PJD RESULTS
PROPOSED BOIS D'ARC RESERVOIR - RAW WATER TRANSMISSION PIPELINE

- Streams 120 FOOT EASEMENT
- Pond 120 FOOT EASEMENT
- Potential Wetlands 120 FOOT EASEMENT
- 120 FOOT TEMPORARY EASEMENT

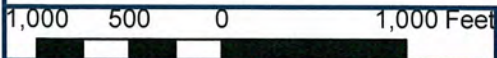

FIGURE 68 OF 73
MARCH 24, 2008



A-68
PJD RESULTS
PROPOSED BOIS D'ARC RESERVOIR - RAW WATER TRANSMISSION PIPELINE

Streams 120 FOOT EASEMENT
Pond 120 FOOT EASEMENT
Potential Wetlands 120 FOOT EASEMENT
120 FOOT TEMPORARY EASEMENT

1,000 500 0 1,000 Feet



FIGURE 69 OF 73
MARCH 24, 2008



A-69
PJD RESULTS
PROPOSED BOIS D'ARC RESERVOIR - RAW WATER TRANSMISSION PIPELINE

Streams 120 FOOT EASEMENT
Pond 120 FOOT EASEMENT
Potential Wetlands 120 FOOT EASEMENT
120 FOOT TEMPORARY EASEMENT

1,000 500 0 1,000 Feet



FIGURE 70 OF 73
MARCH 24, 2008

T

A-70
PJD RESULTS
PROPOSED BOIS D'ARC RESERVOIR - RAW WATER TRANSMISSION PIPELINE

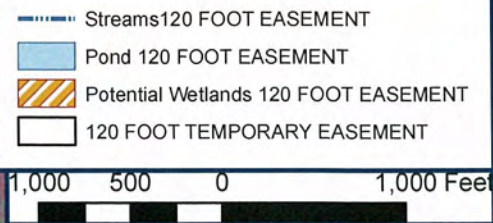

FIGURE 71 OF 73
MARCH 24, 2008

A-71
PJD RESULTS
PROPOSED BOIS D'ARC RESERVOIR - RAW WATER TRANSMISSION PIPELINE

- Streams 120 FOOT EASEMENT
- Pond 120 FOOT EASEMENT
- Potential Wetlands 120 FOOT EASEMENT
- 120 FOOT TEMPORARY EASEMENT

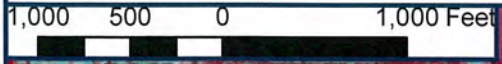
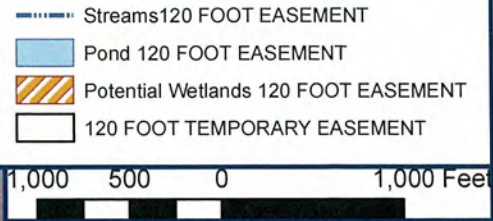

FIGURE 72 OF 73
MARCH 24, 2008



A-72
PJD RESULTS
PROPOSED BOIS D'ARC RESERVOIR - RAW WATER TRANSMISSION PIPELINE



P 16

S 85

S 86

S 87

FIGURE 73 OF 73
MARCH 24, 2008

W

APPENDIX B
RECENT PHOTOGRAPHS

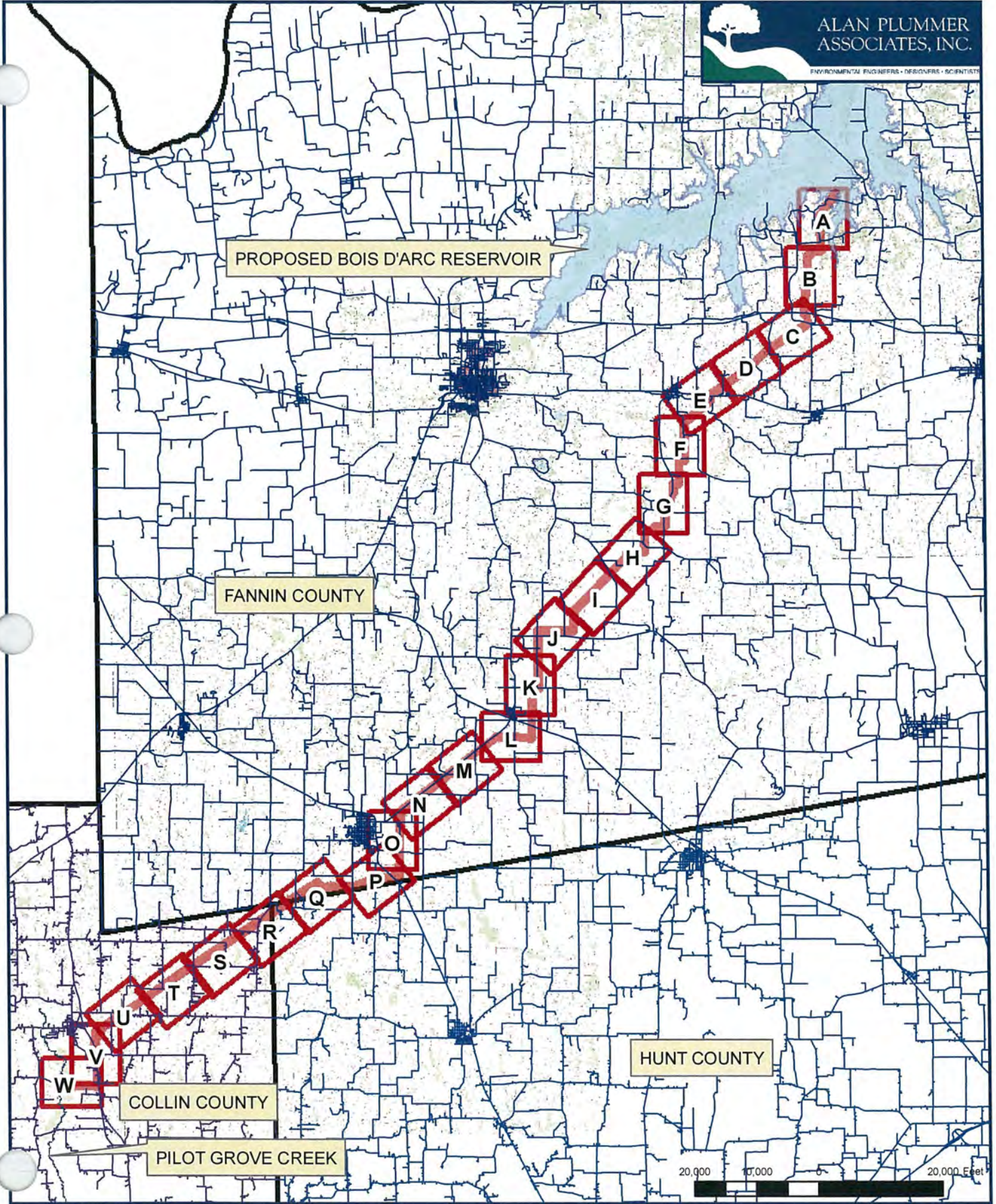

B-1

FIELD INVESTIGATION PHOTOGRAPH LOCATION PLATES
PROPOSED BOIS D'ARC RESERVOIR - RAW WATER TRANSMISSION PIPELINE

FIGURE 1 OF 24
MARCH 25, 2008

120 FOOT TEMPORARY EASEMENT

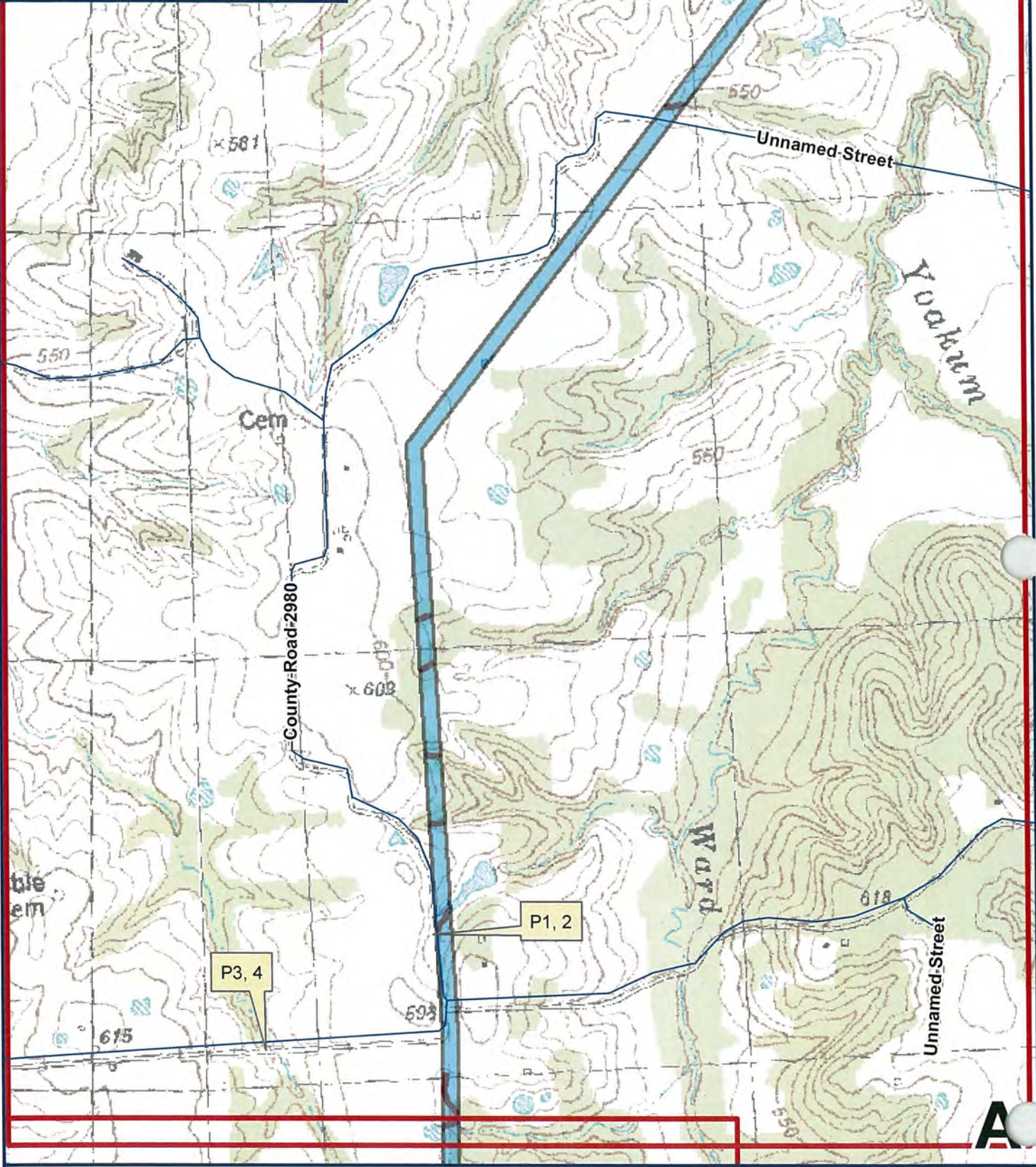

B-2

FIELD INVESTIGATION PHOTOGRAPHS

FIGURE 2 OF 24
MARCH 24, 2008

PROPOSED BOIS D'ARC RESERVOIR - RAW WATER TRANSMISSION PIPELINE

120 FOOT TEMPORARY EASEMENT

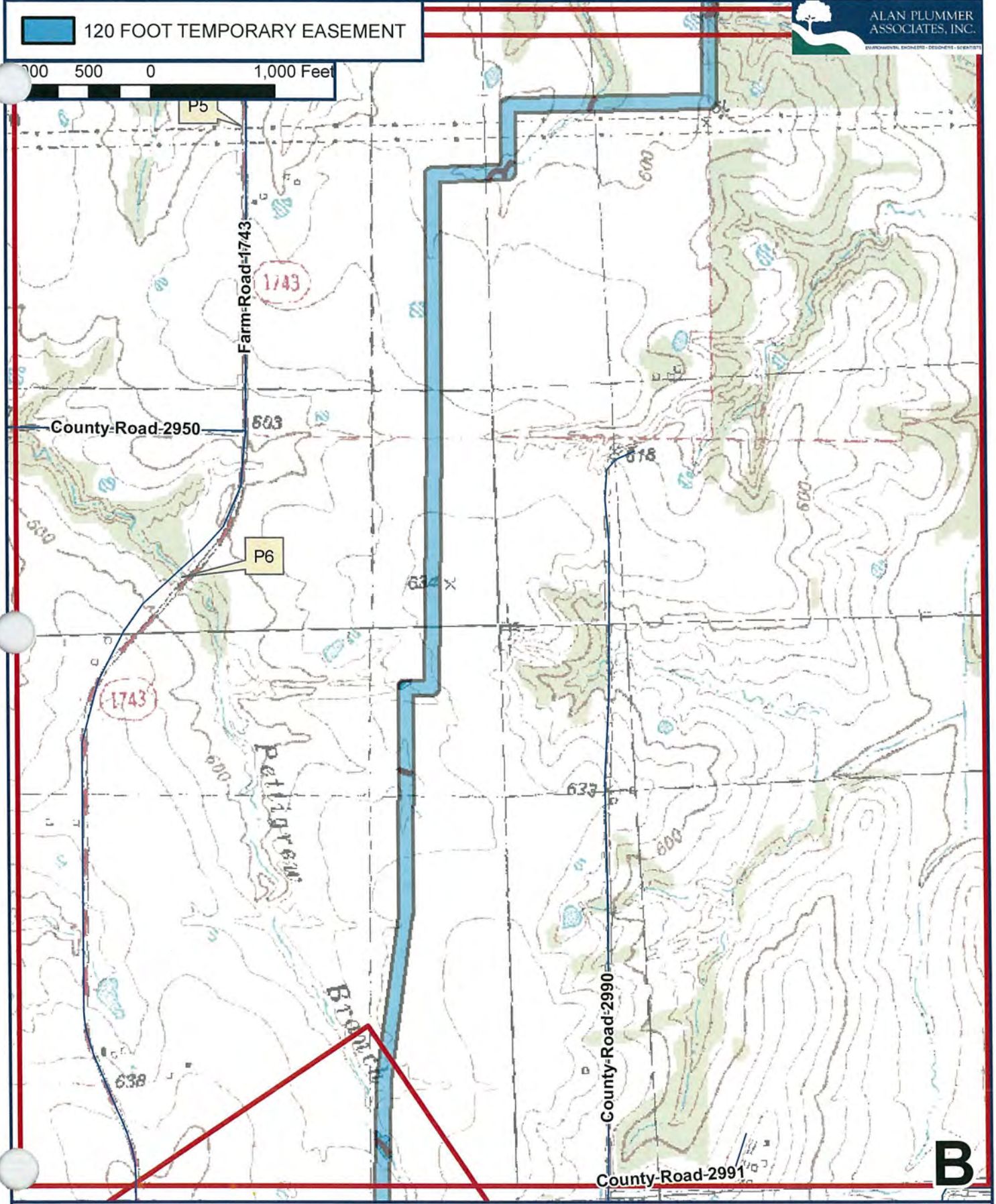
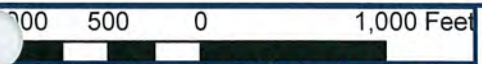

B-3

FIELD INVESTIGATION PHOTOGRAPHS

FIGURE 3 OF 24
MARCH 24, 2008

PROPOSED BOIS D'ARC RESERVOIR - RAW WATER TRANSMISSION PIPELINE

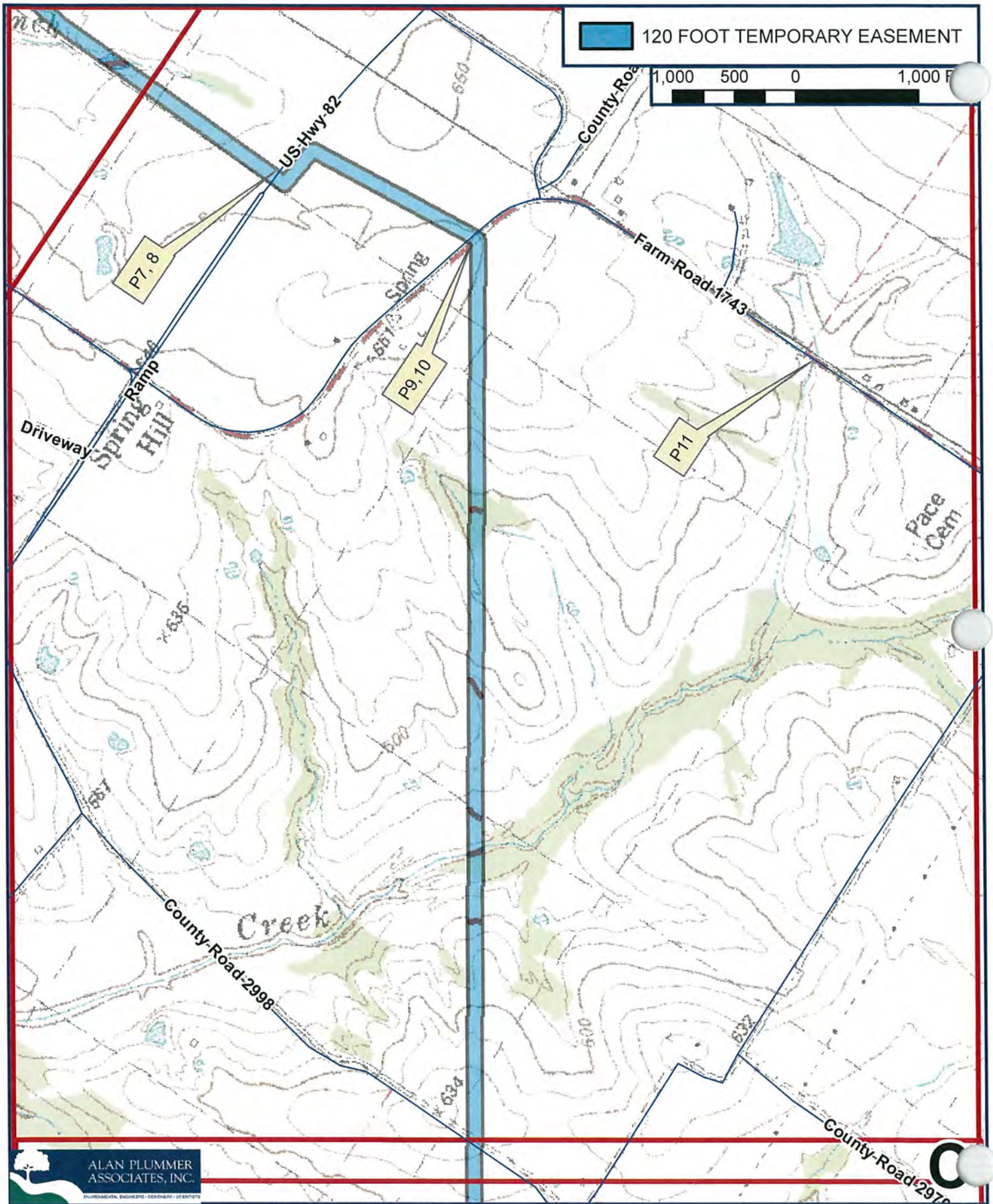

B-4

FIGURE 4 OF 24
MARCH 24, 2008

FIELD INVESTIGATION PHOTOGRAPHS
PROPOSED BOIS D'ARC RESERVOIR - RAW WATER TRANSMISSION PIPELINE

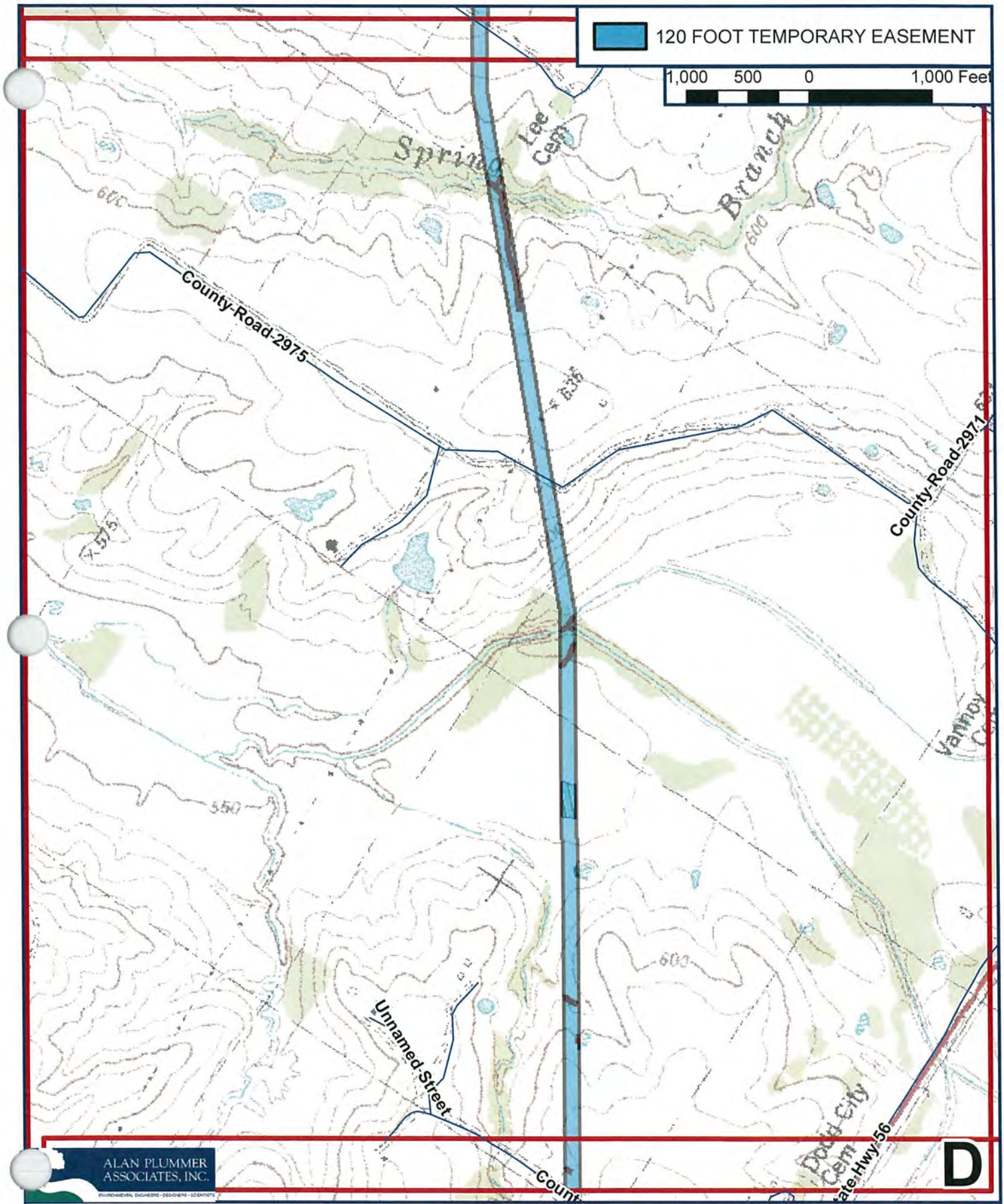

ALAN PLUMMER
ASSOCIATES, INC.

ENVIRONMENTAL ENGINEERS - DESIGNERS - SCIENTISTS

B-5

FIELD INVESTIGATION PHOTOGRAPHS

FIGURE 5 OF 24
MARCH 24, 2008

PROPOSED BOIS D'ARC RESERVOIR - RAW WATER TRANSMISSION PIPELINE

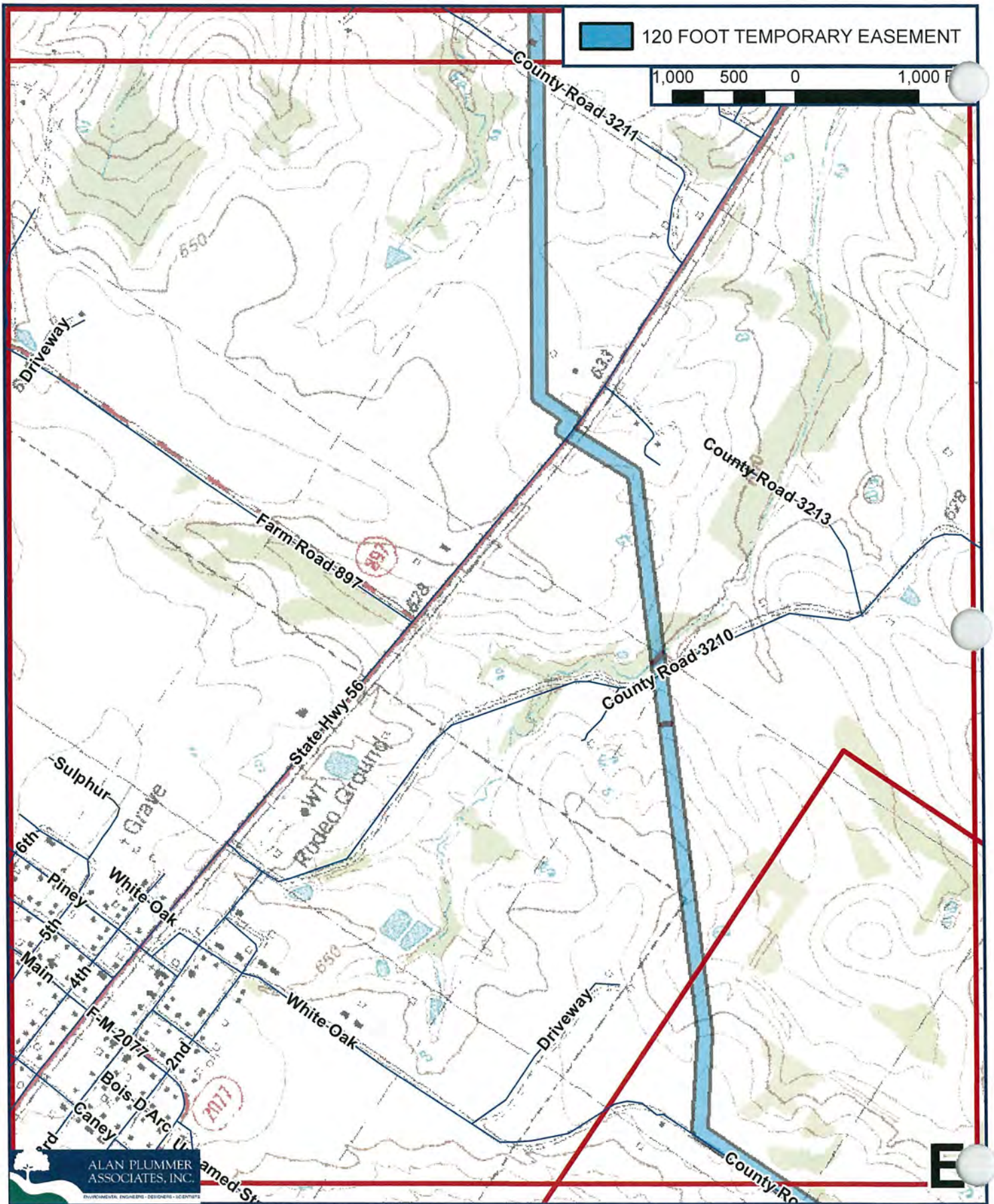

B-6

FIELD INVESTIGATION PHOTOGRAPHS

FIGURE 6 OF 24
MARCH 24, 2008

PROPOSED BOIS D'ARC RESERVOIR - RAW WATER TRANSMISSION PIPELINE

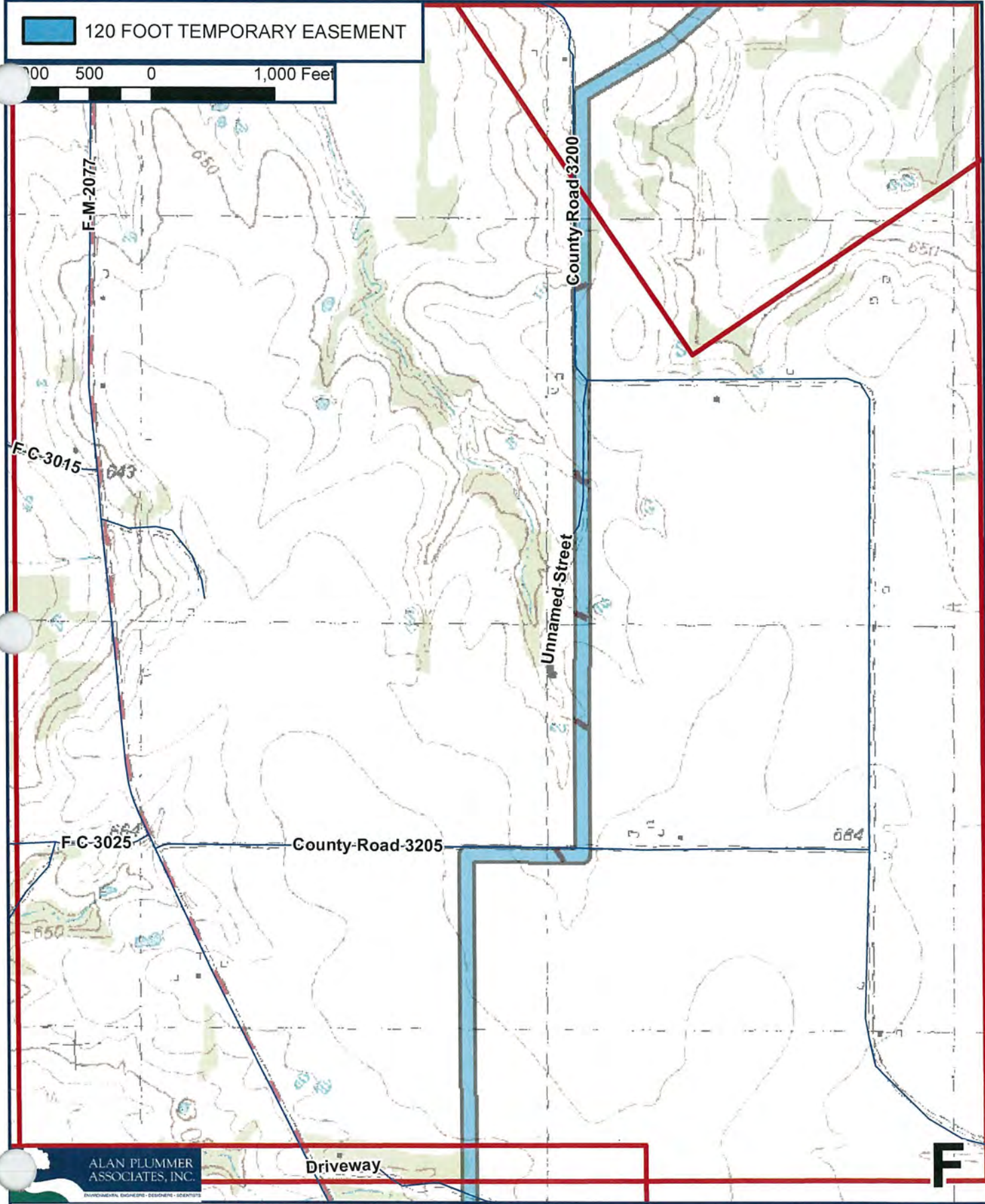

120 FOOT TEMPORARY EASEMENT

0 500 0 1,000 Feet

F-M-2077

County Road 3200

Unnamed Street

F-C-3025

County Road 3205

Driveway

ALAN PLUMMER ASSOCIATES, INC.
ENVIRONMENTAL ENGINEERS - DESIGNERS - SCIENTISTS

F

B-7

FIELD INVESTIGATION PHOTOGRAPHS

FIGURE 7 OF 24
MARCH 24, 2008

PROPOSED BOIS D'ARC RESERVOIR - RAW WATER TRANSMISSION PIPELINE

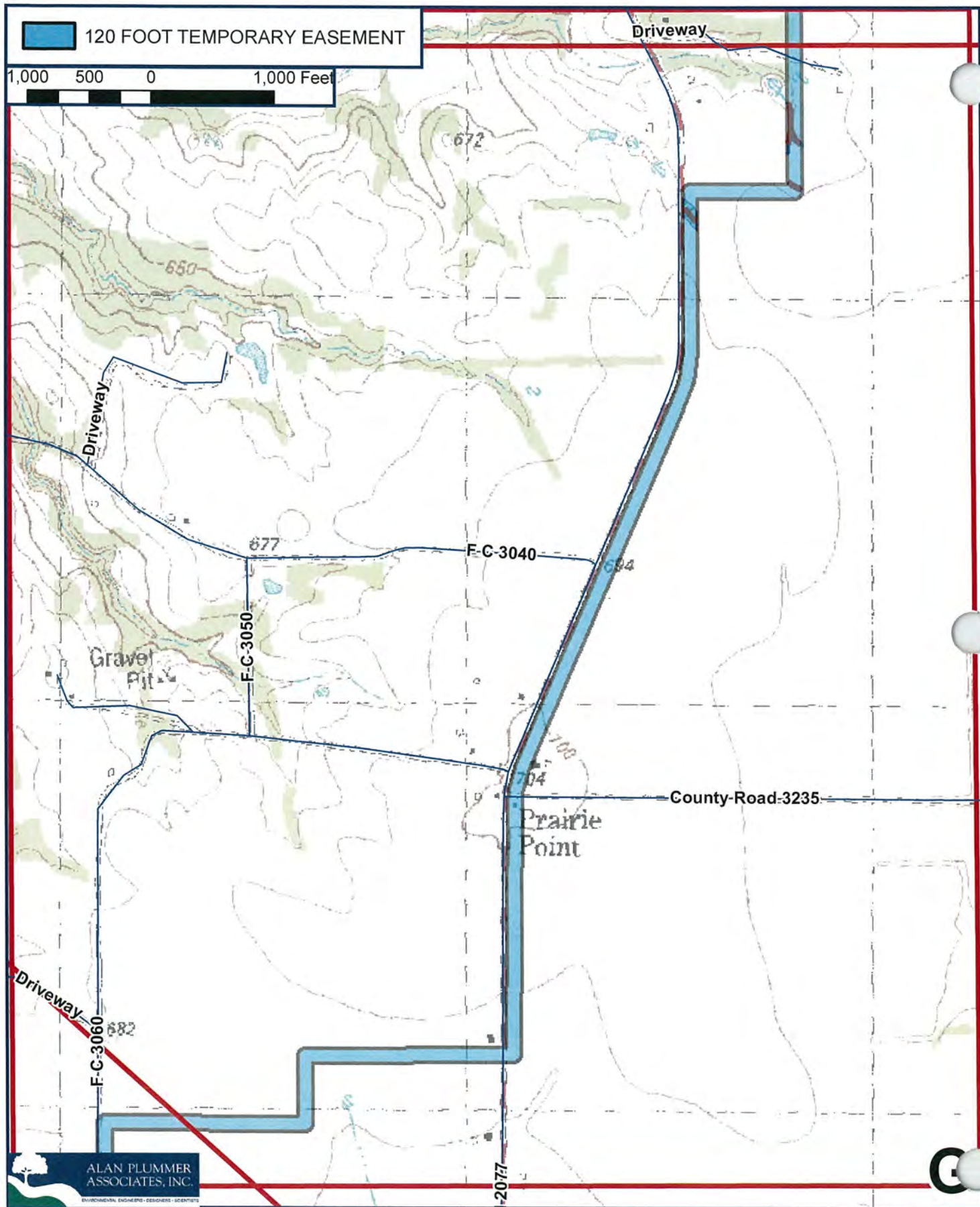

B-8

FIELD INVESTIGATION PHOTOGRAPHS

FIGURE 8 OF 24
MARCH 24, 2008

PROPOSED BOIS D'ARC RESERVOIR - RAW WATER TRANSMISSION PIPELINE

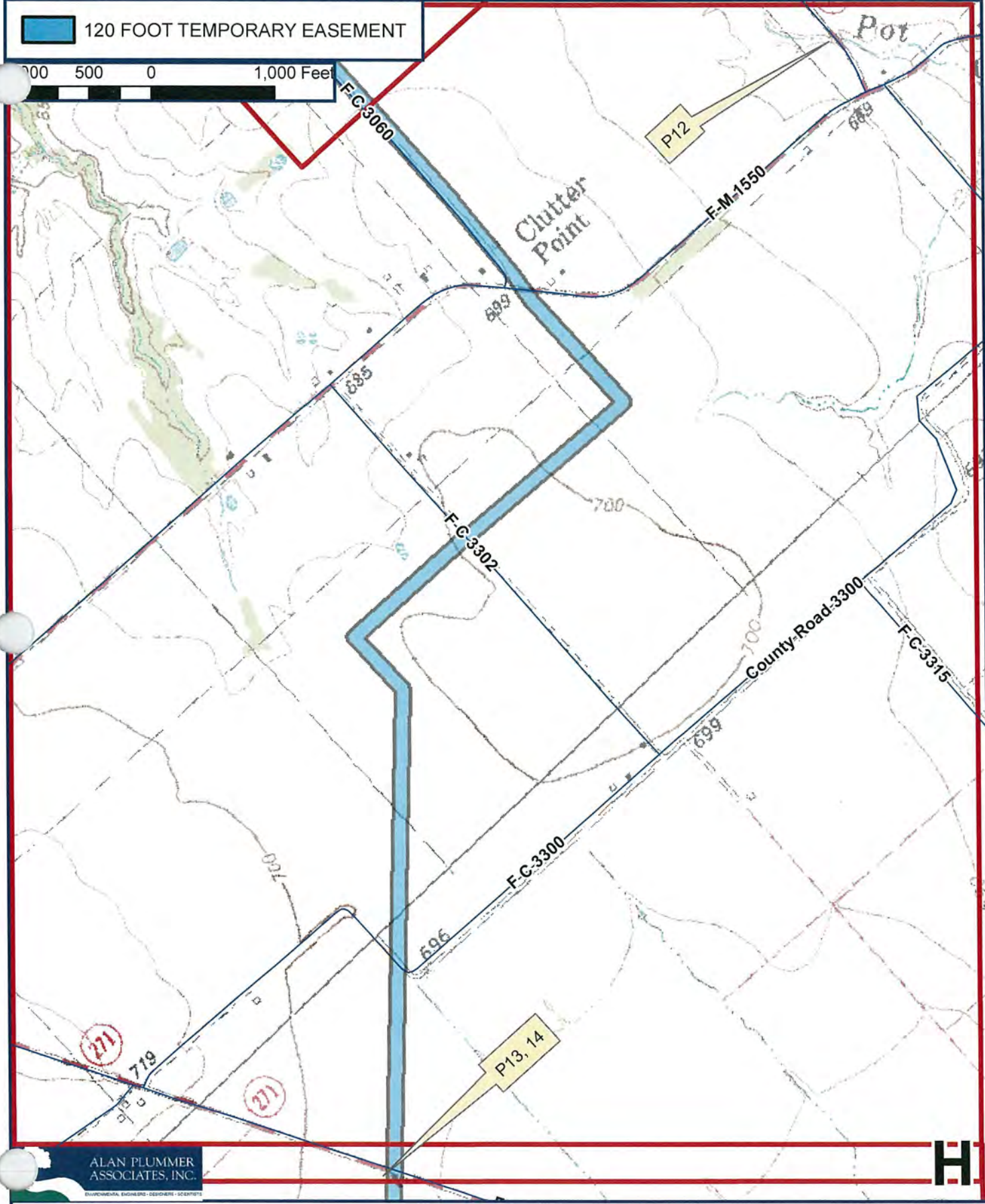

B-9

FIELD INVESTIGATION PHOTOGRAPHS

FIGURE 9 OF 24
MARCH 24, 2008

PROPOSED BOIS D'ARC RESERVOIR - RAW WATER TRANSMISSION PIPELINE

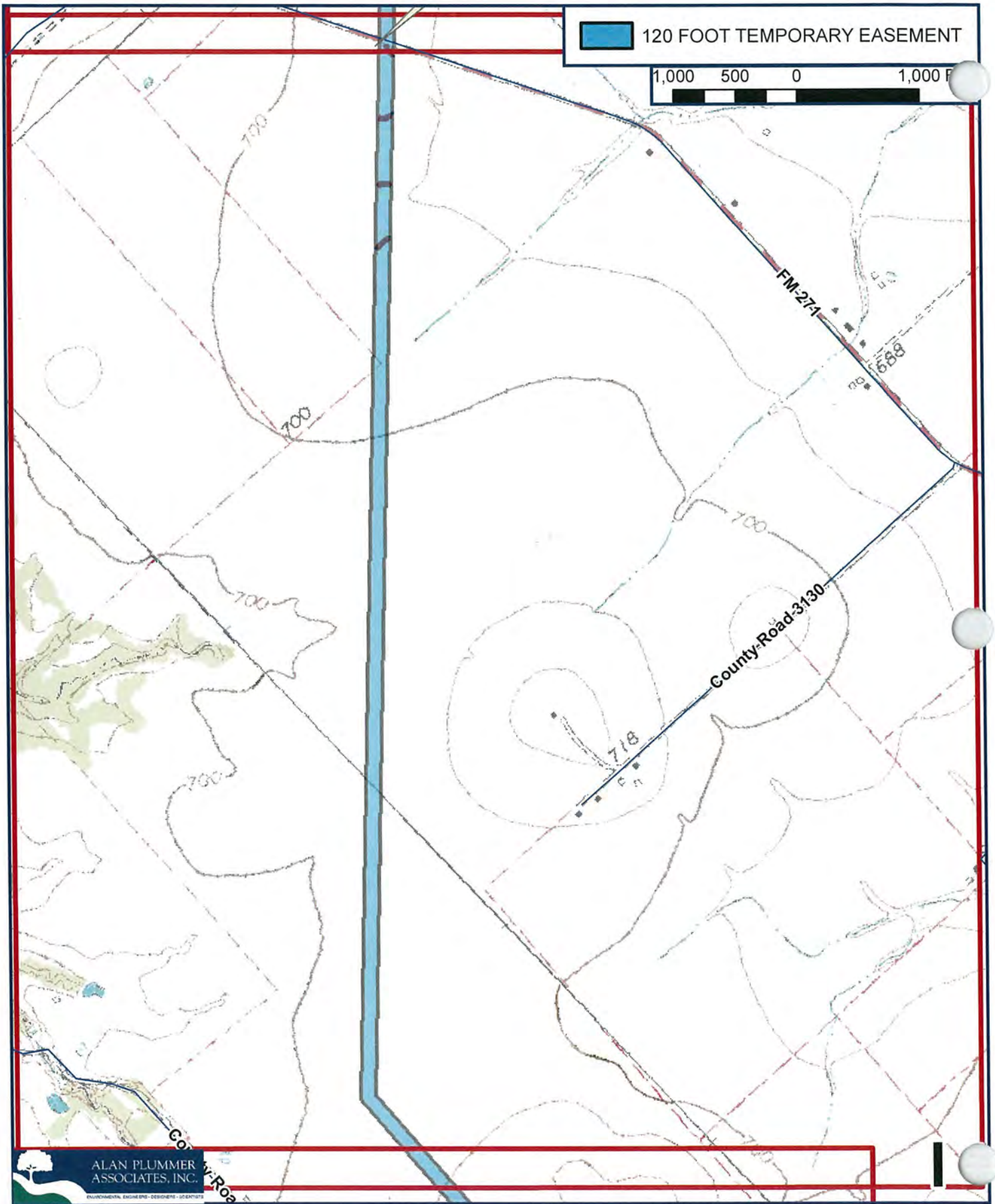

B-10

FIGURE 10 OF 24
MARCH 24, 2008

FIELD INVESTIGATION PHOTOGRAPHS

PROPOSED BOIS D'ARC RESERVOIR - RAW WATER TRANSMISSION PIPELINE

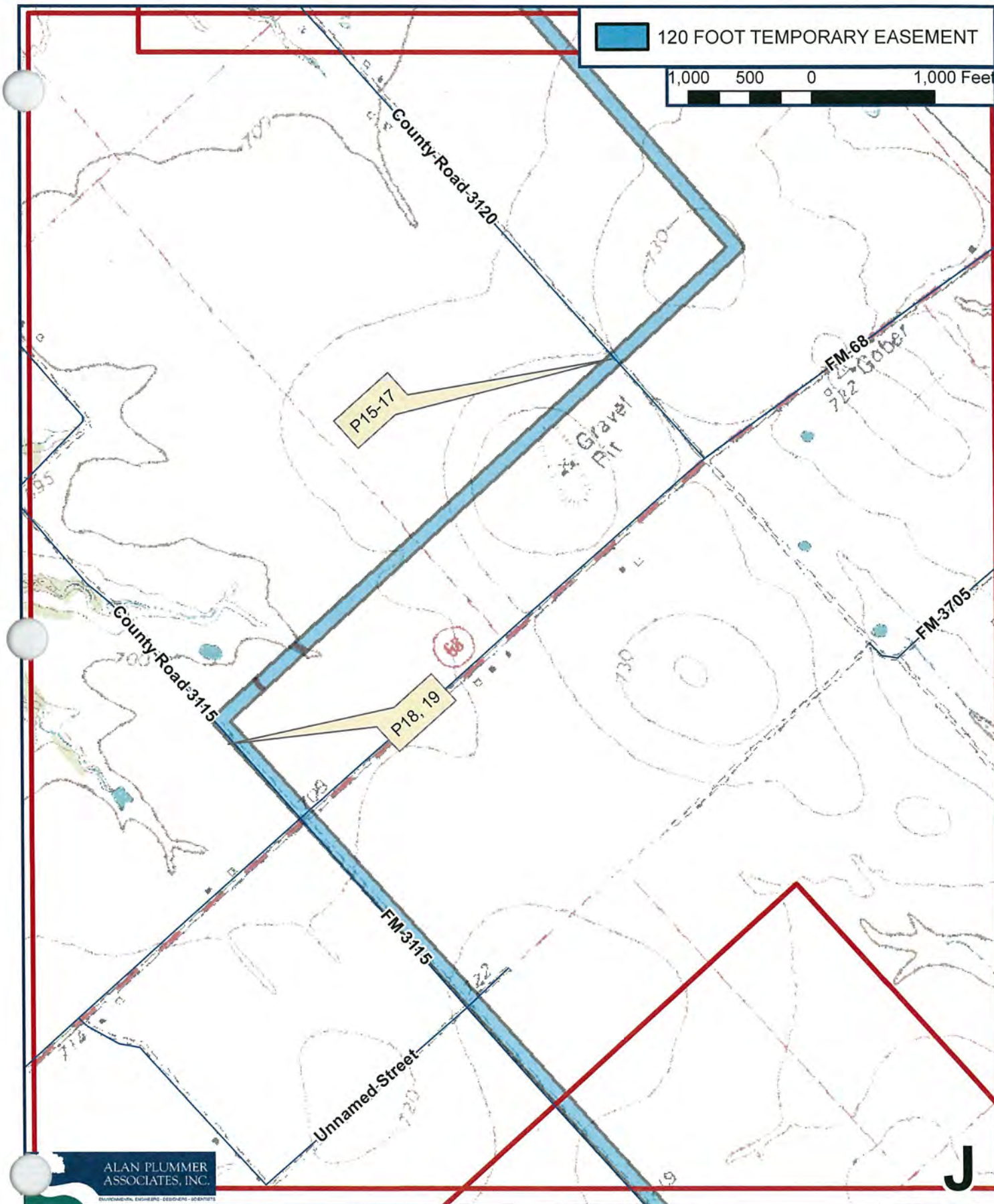

B-11

FIELD INVESTIGATION PHOTOGRAPHS

FIGURE 10 OF 24
MARCH 24, 2008

PROPOSED BOIS D'ARC RESERVOIR - RAW WATER TRANSMISSION PIPELINE

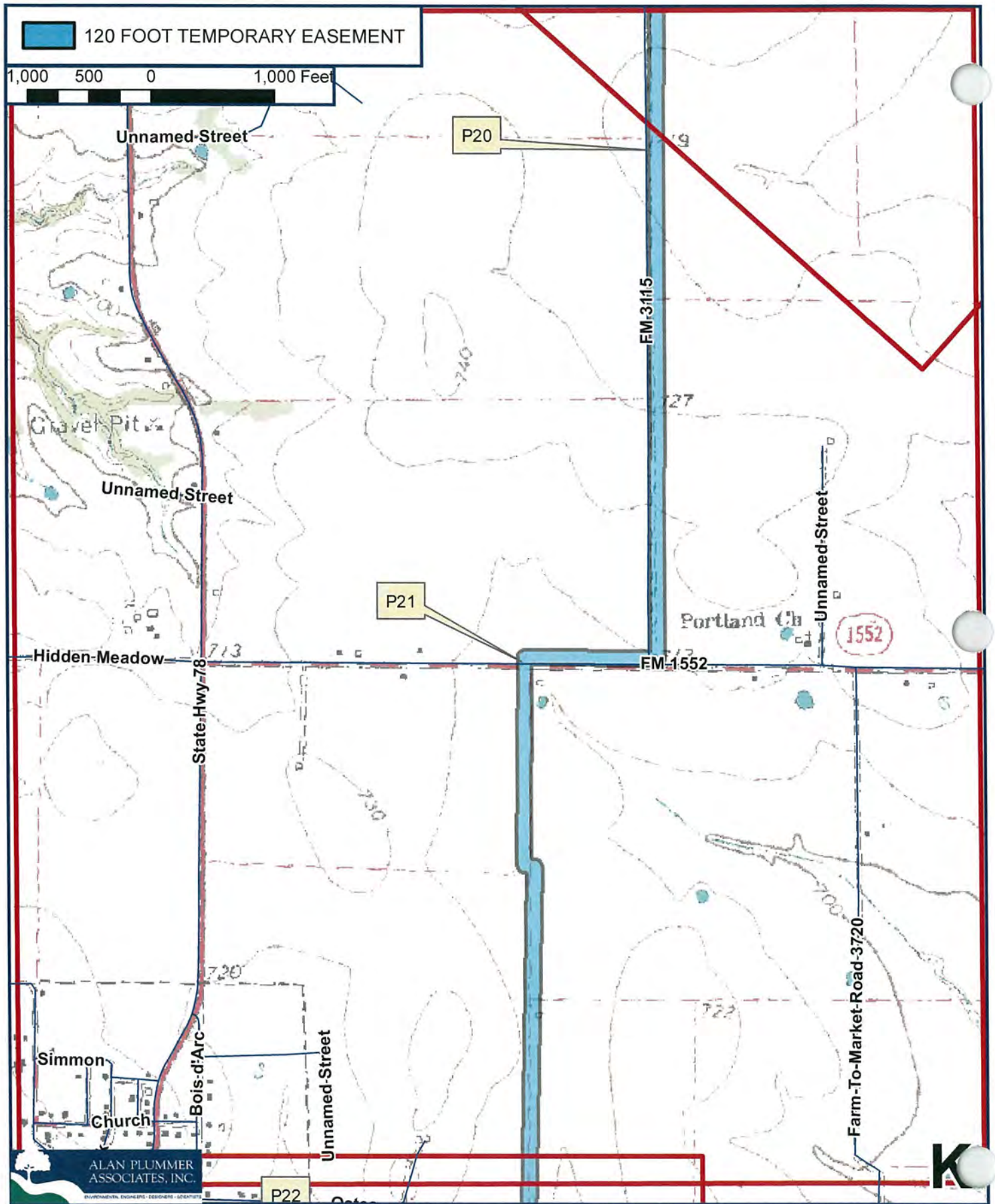

B-12

FIELD INVESTIGATION PHOTOGRAPHS

FIGURE 12 OF 24
MARCH 24, 2008

PROPOSED BOIS D'ARC RESERVOIR - RAW WATER TRANSMISSION PIPELINE

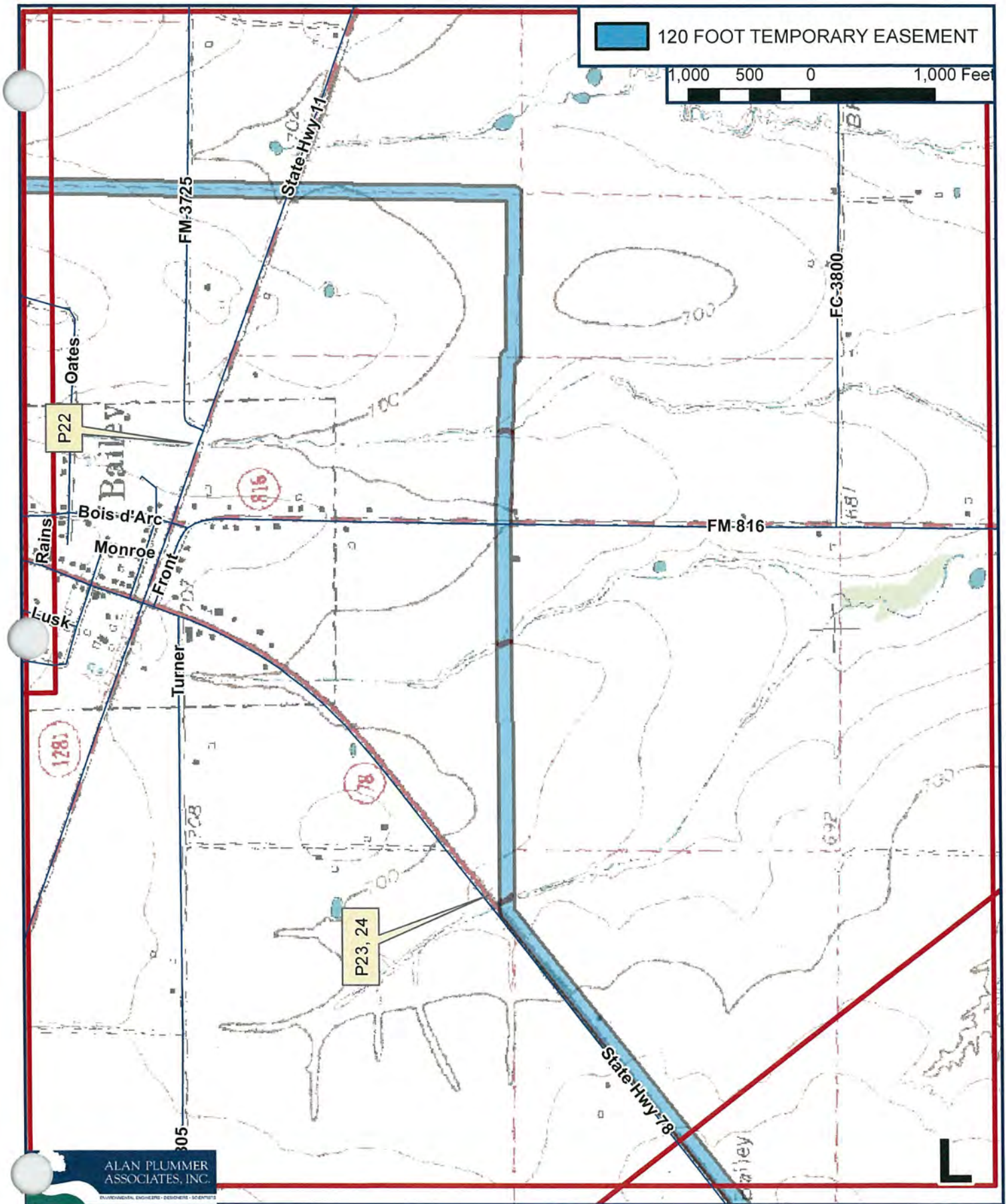

ALAN PLUMMER
ASSOCIATES, INC.

PLANNING ENGINEERS - DESIGNERS - SCIENTISTS

B-13

FIELD INVESTIGATION PHOTOGRAPHS

FIGURE 13 OF 24
MARCH 24, 2008

PROPOSED BOIS D'ARC RESERVOIR - RAW WATER TRANSMISSION PIPELINE

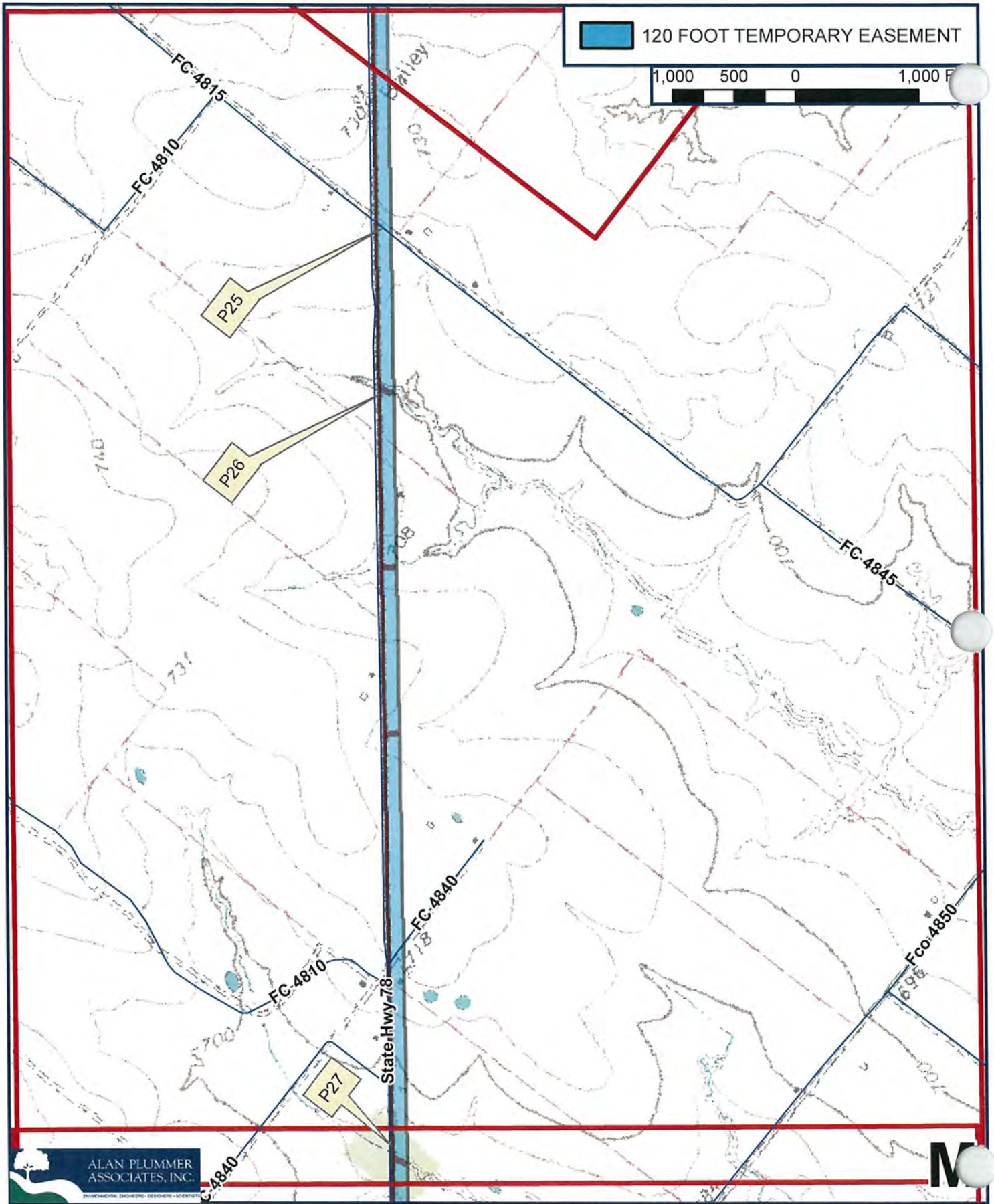

B-14

FIELD INVESTIGATION PHOTOGRAPHS

FIGURE 14 OF 24
MARCH 24, 2008

PROPOSED BOIS D'ARC RESERVOIR - RAW WATER TRANSMISSION PIPELINE

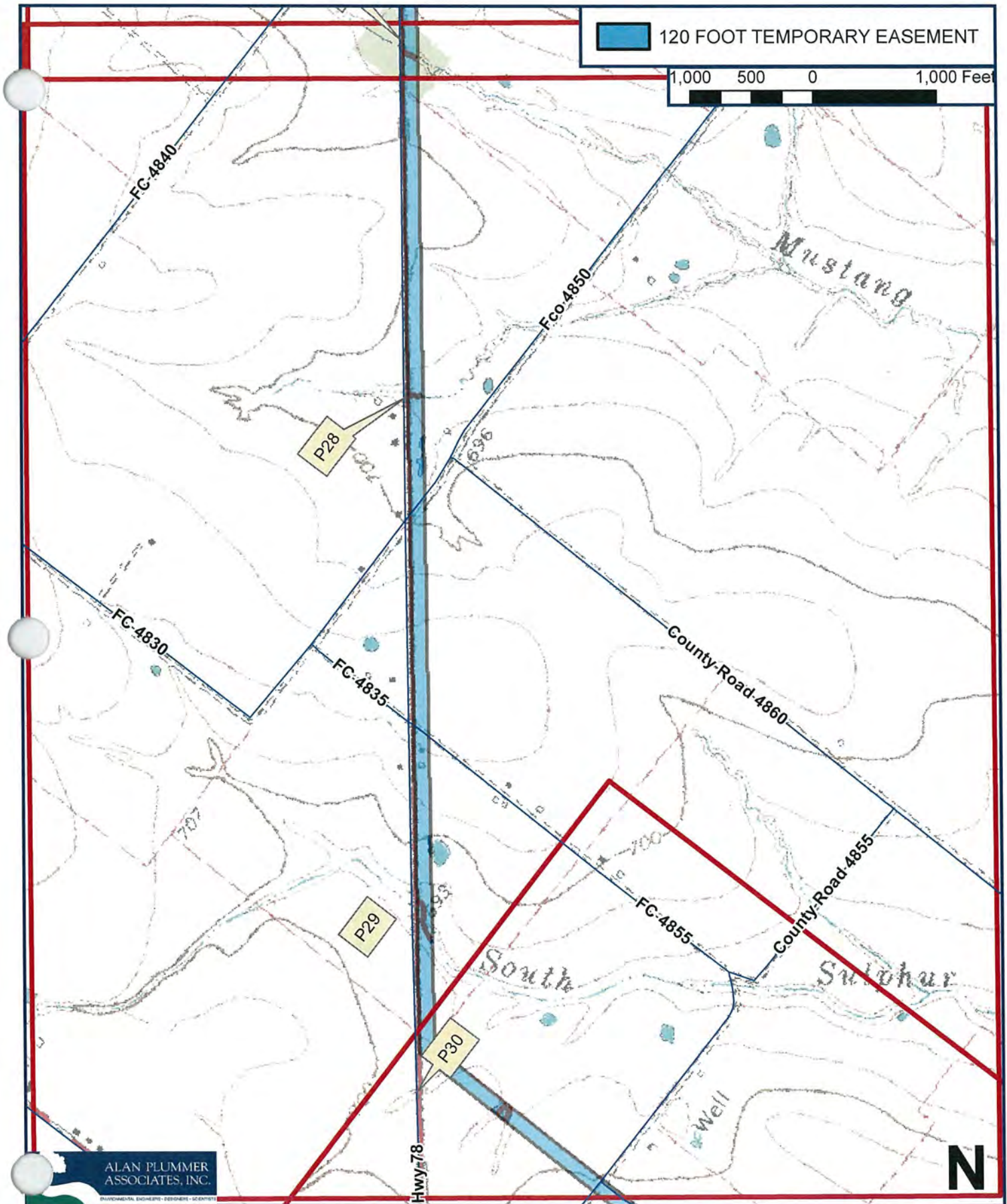

ALAN PLUMMER
ASSOCIATES, INC.

ENVIRONMENTAL ENGINEERS - DESIGNERS - SCIENTISTS

B-15

FIELD INVESTIGATION PHOTOGRAPHS

FIGURE 15 OF 24
MARCH 24, 2008

PROPOSED BOIS D'ARC RESERVOIR - RAW WATER TRANSMISSION PIPELINE

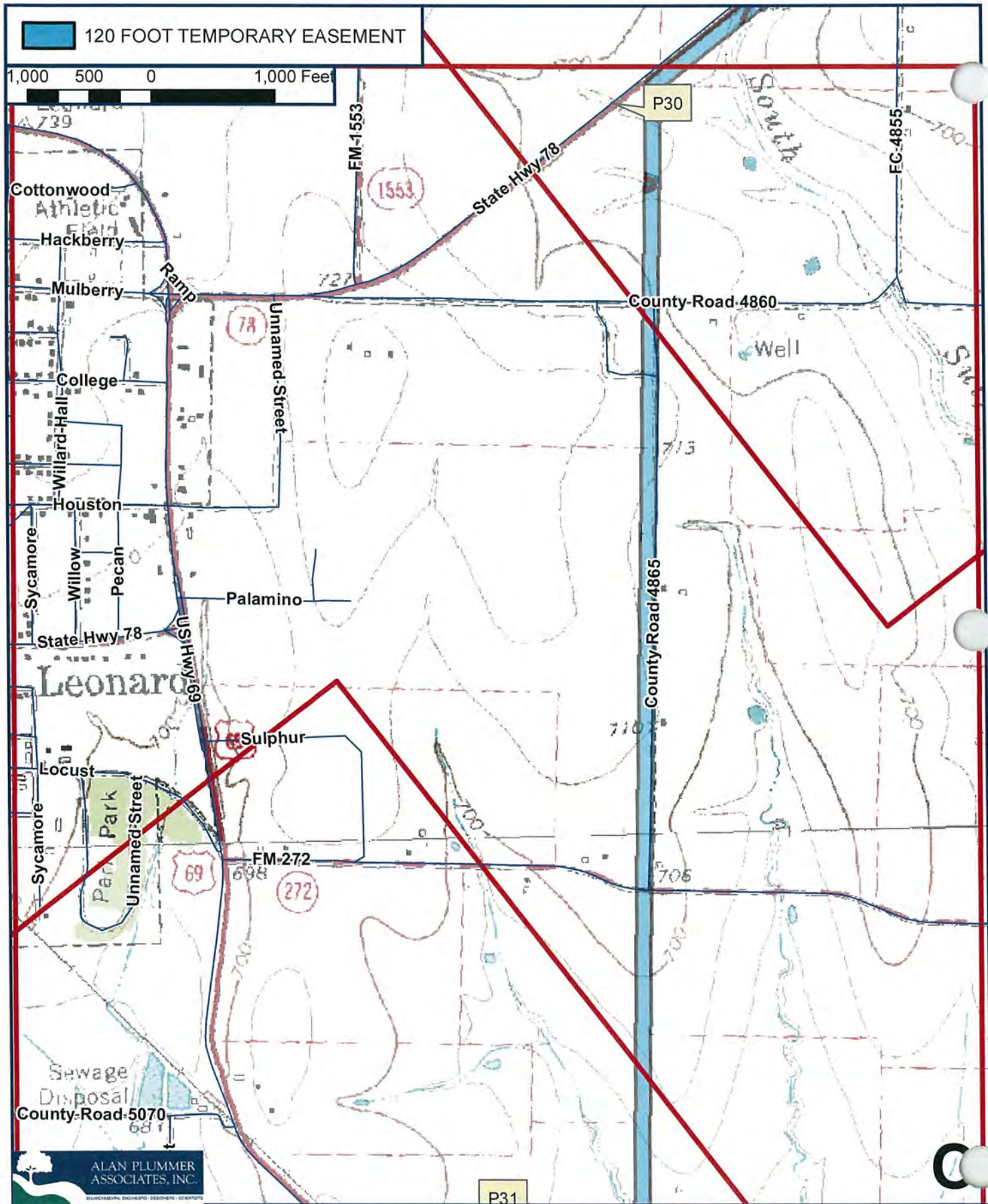

ALAN PLUMMER ASSOCIATES, INC.
ENVIRONMENTAL ENGINEERS • DESIGNERS • SCIENTISTS

P31

B-16

FIELD INVESTIGATION PHOTOGRAPHS

FIGURE 16 OF 24 **PROPOSED BOIS D'ARC RESERVOIR - RAW WATER TRANSMISSION PIPELINE**

MARCH 24, 2008

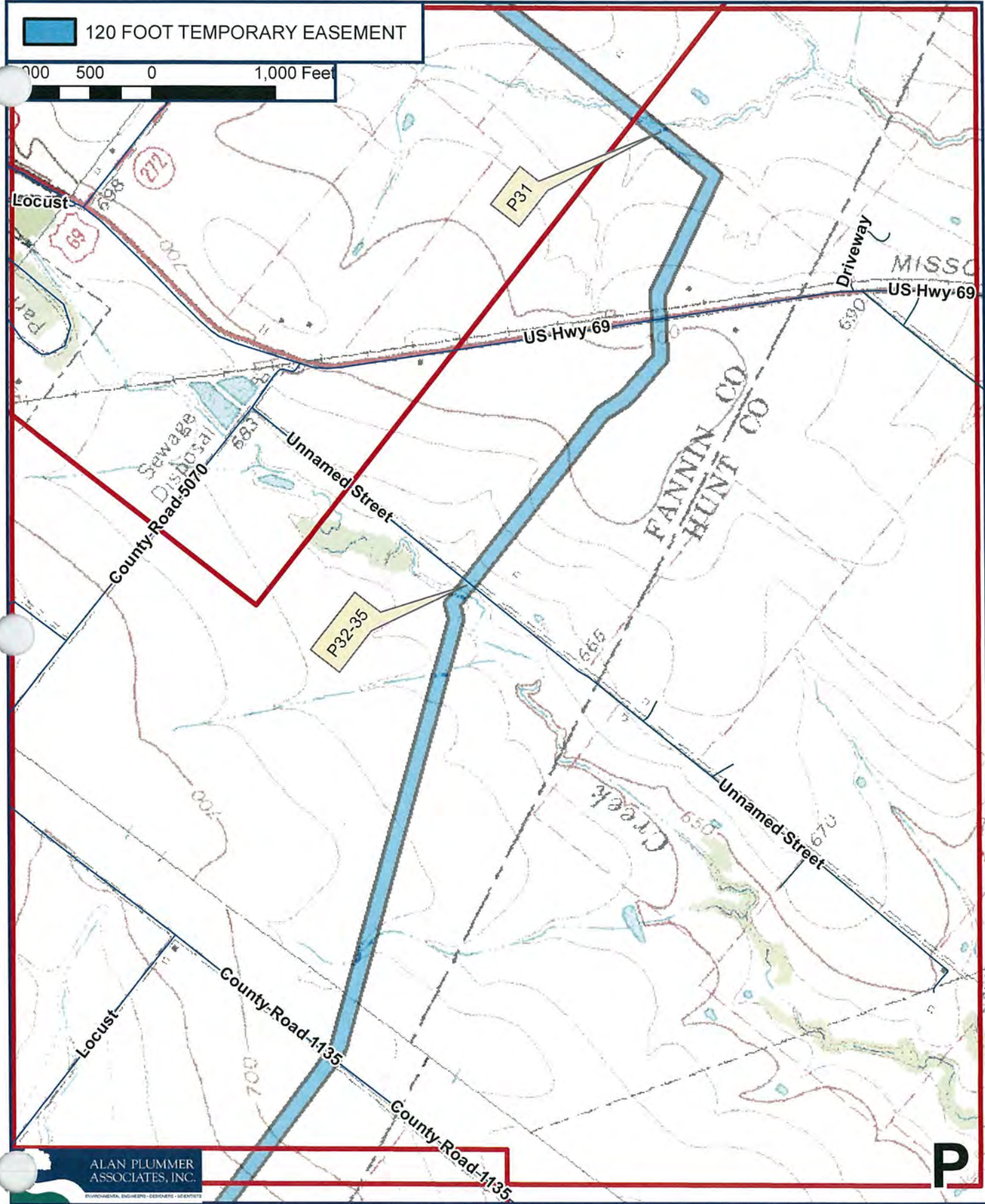

B-17

FIGURE 17 OF 24
MARCH 24, 2008

FIELD INVESTIGATION PHOTOGRAPHS

PROPOSED BOIS D'ARC RESERVOIR - RAW WATER TRANSMISSION PIPELINE

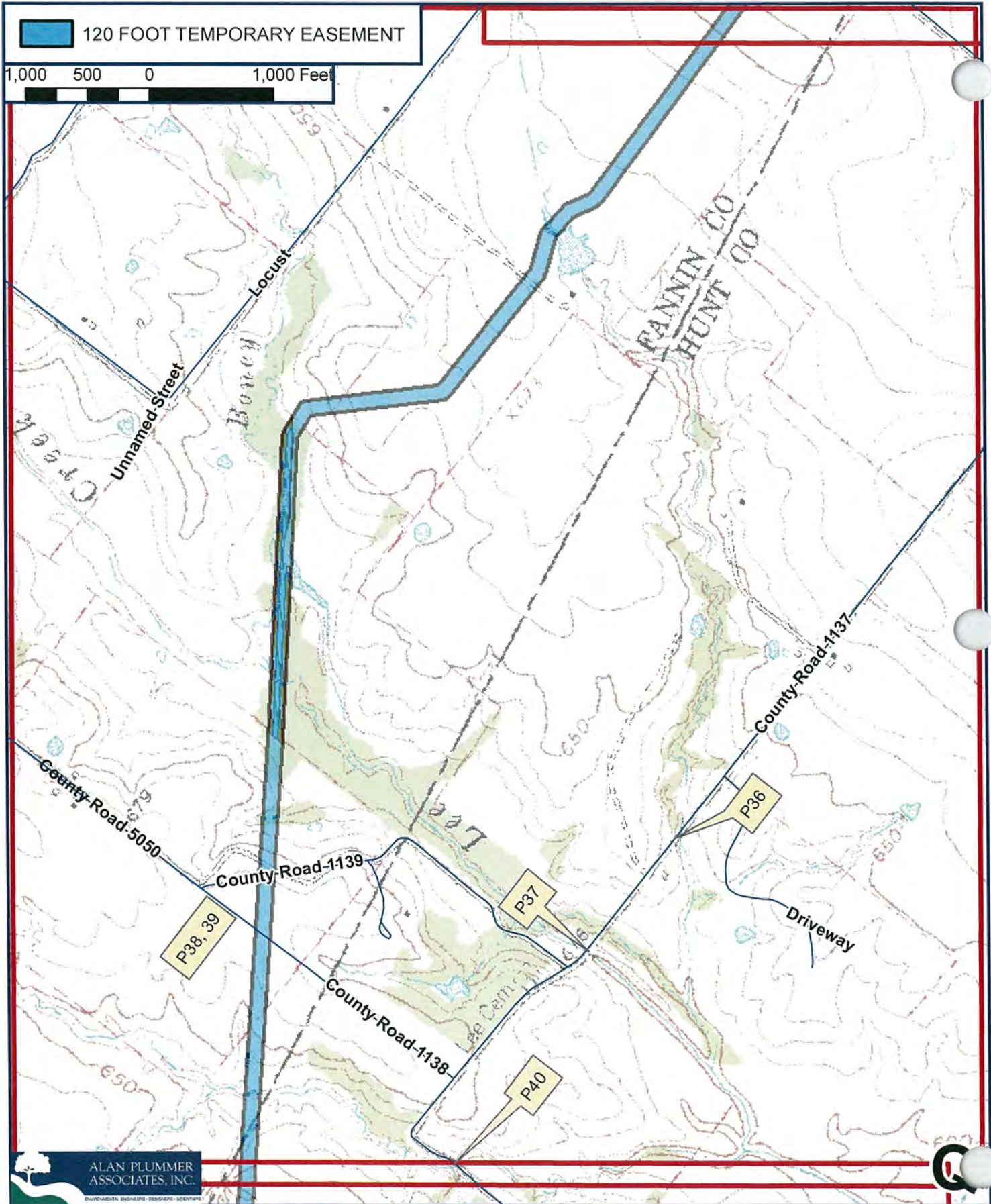

B-18

FIGURE 18 OF 24
MARCH 24, 2008

FIELD INVESTIGATION PHOTOGRAPHS

PROPOSED BOIS D'ARC RESERVOIR - RAW WATER TRANSMISSION PIPELINE

120 FOOT TEMPORARY EASEMENT

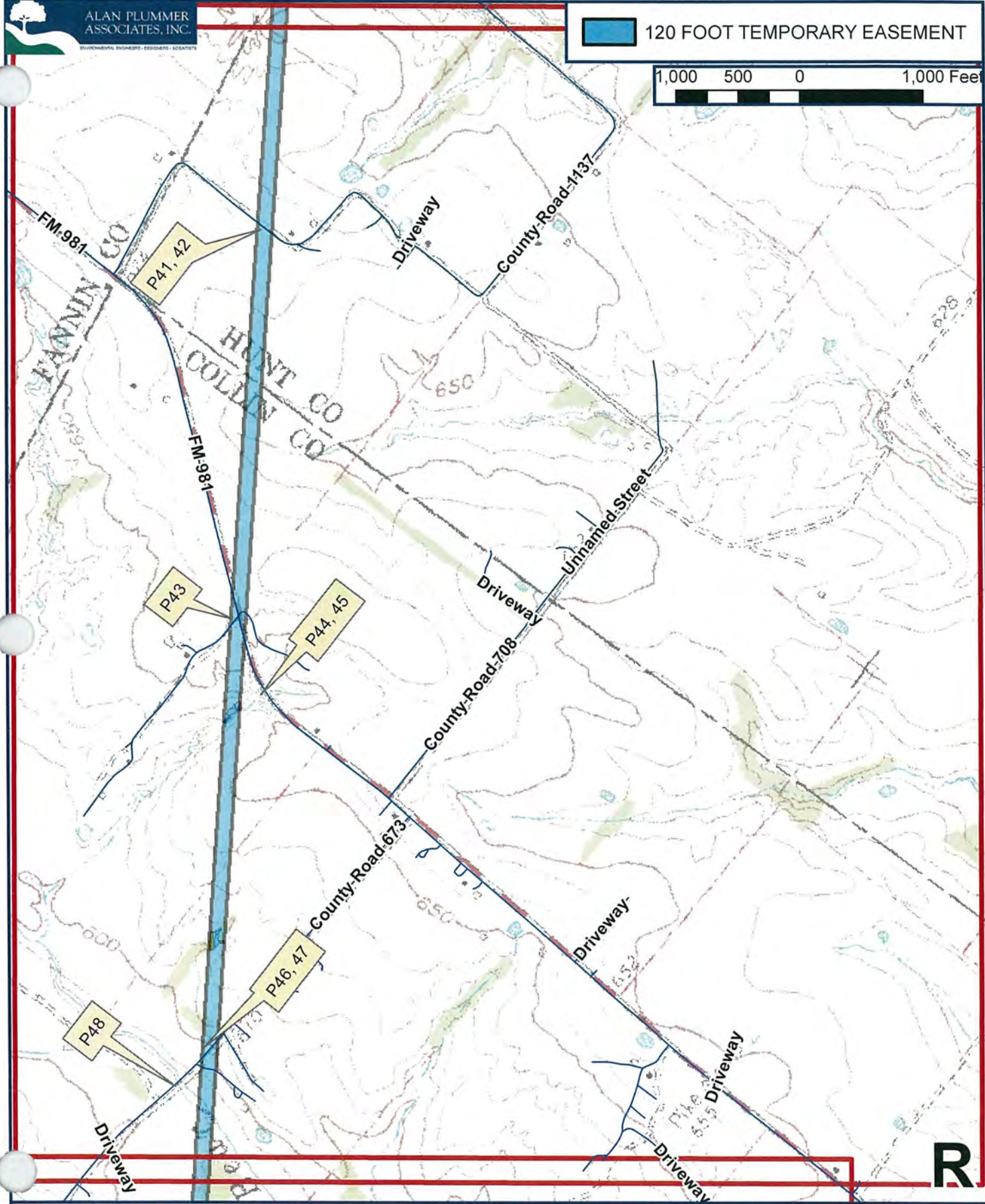
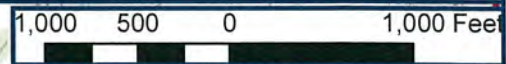

R

B-19

FIELD INVESTIGATION PHOTOGRAPHS

FIGURE 19 OF 24
MARCH 24, 2008

PROPOSED BOIS D'ARC RESERVOIR - RAW WATER TRANSMISSION PIPELINE

120 FOOT TEMPORARY EASEMENT

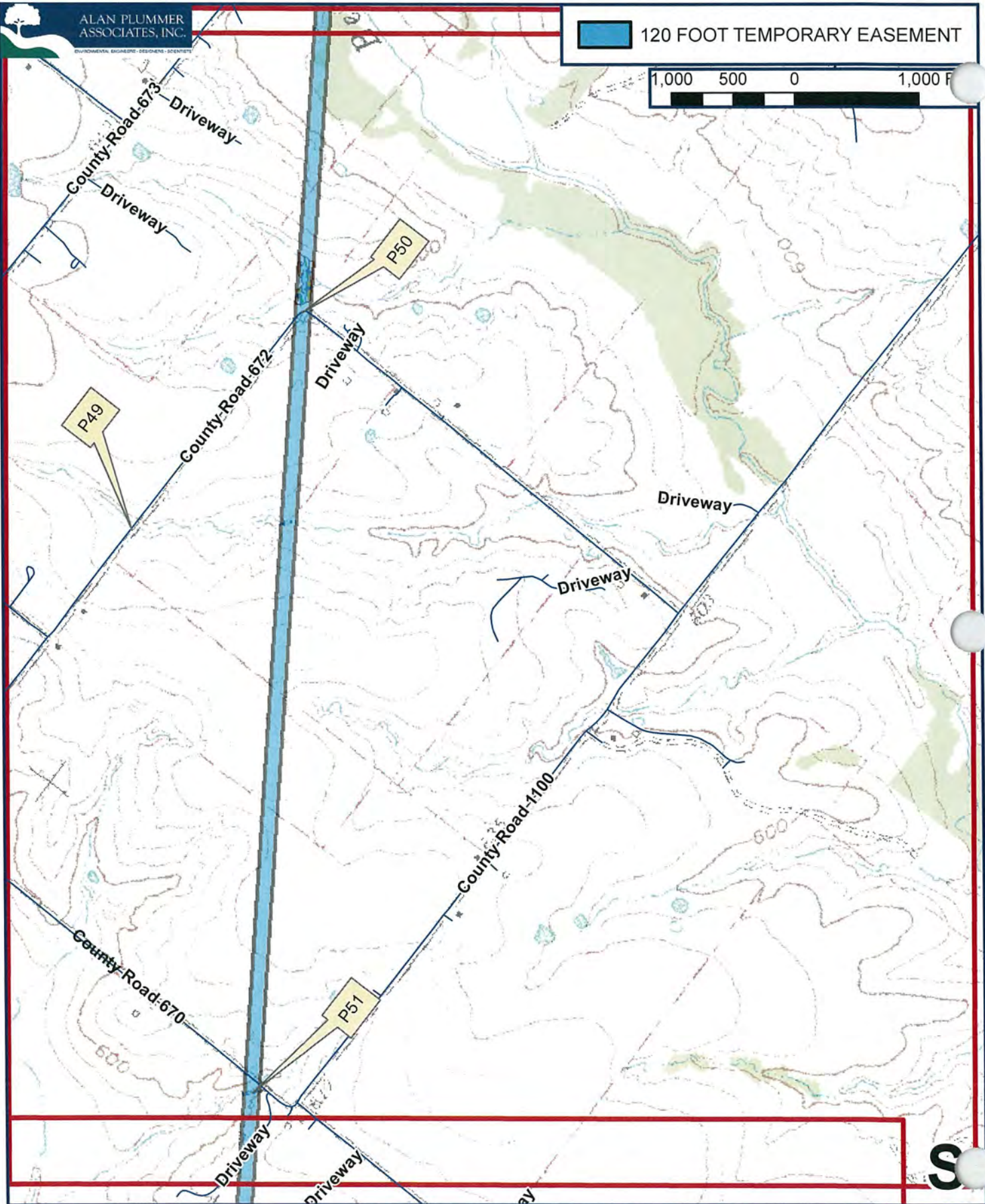
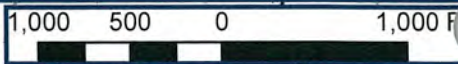

B-20

FIGURE 20 OF 24
MARCH 24, 2008

FIELD INVESTIGATION PHOTOGRAPHS
PROPOSED BOIS D'ARC RESERVOIR - RAW WATER TRANSMISSION PIPELINE

120 FOOT TEMPORARY EASEMENT

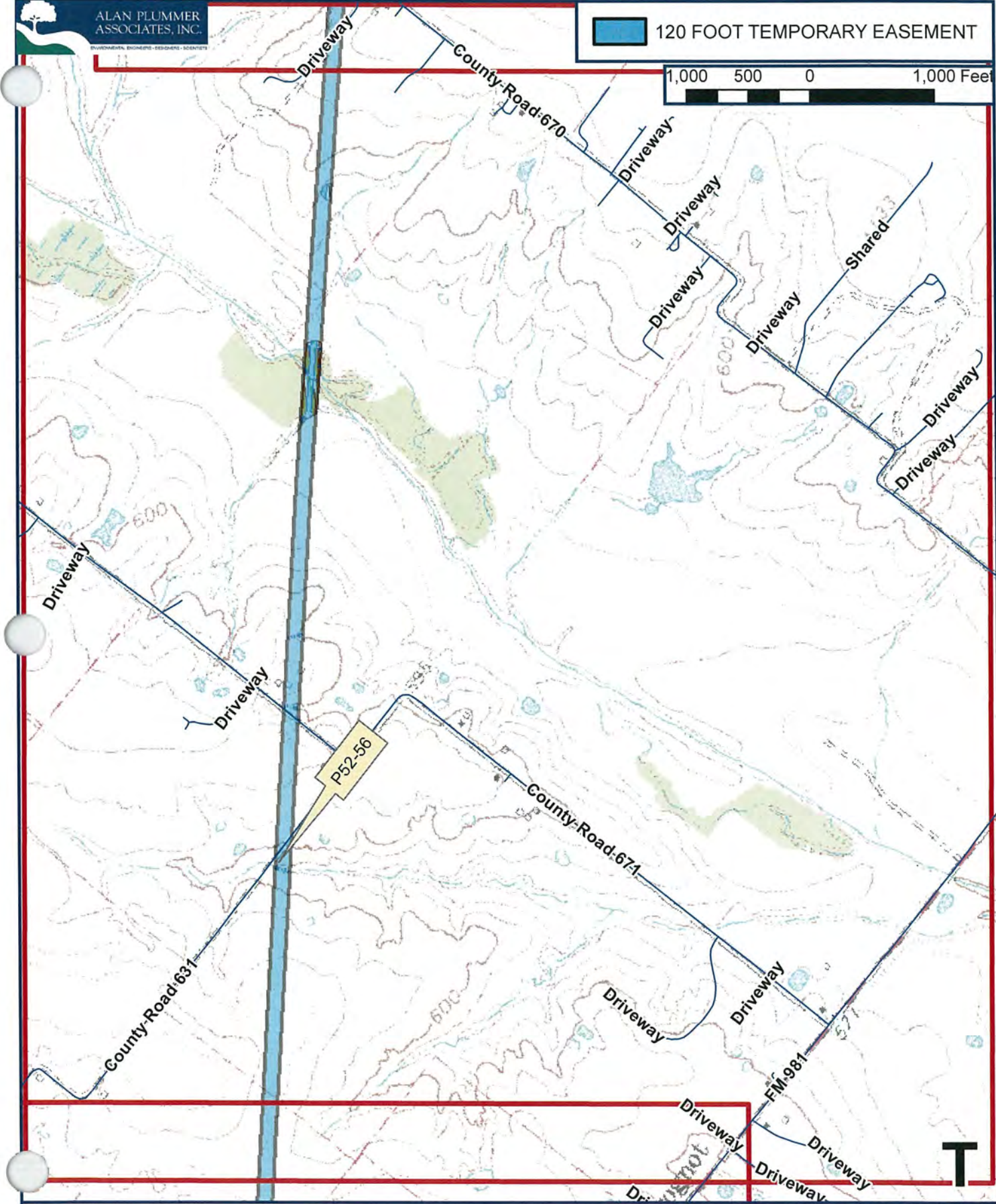

B-21

FIELD INVESTIGATION PHOTOGRAPHS

FIGURE 21 OF 24
MARCH 24, 2008

PROPOSED BOIS D'ARC RESERVOIR - RAW WATER TRANSMISSION PIPELINE

120 FOOT TEMPORARY EASEMENT

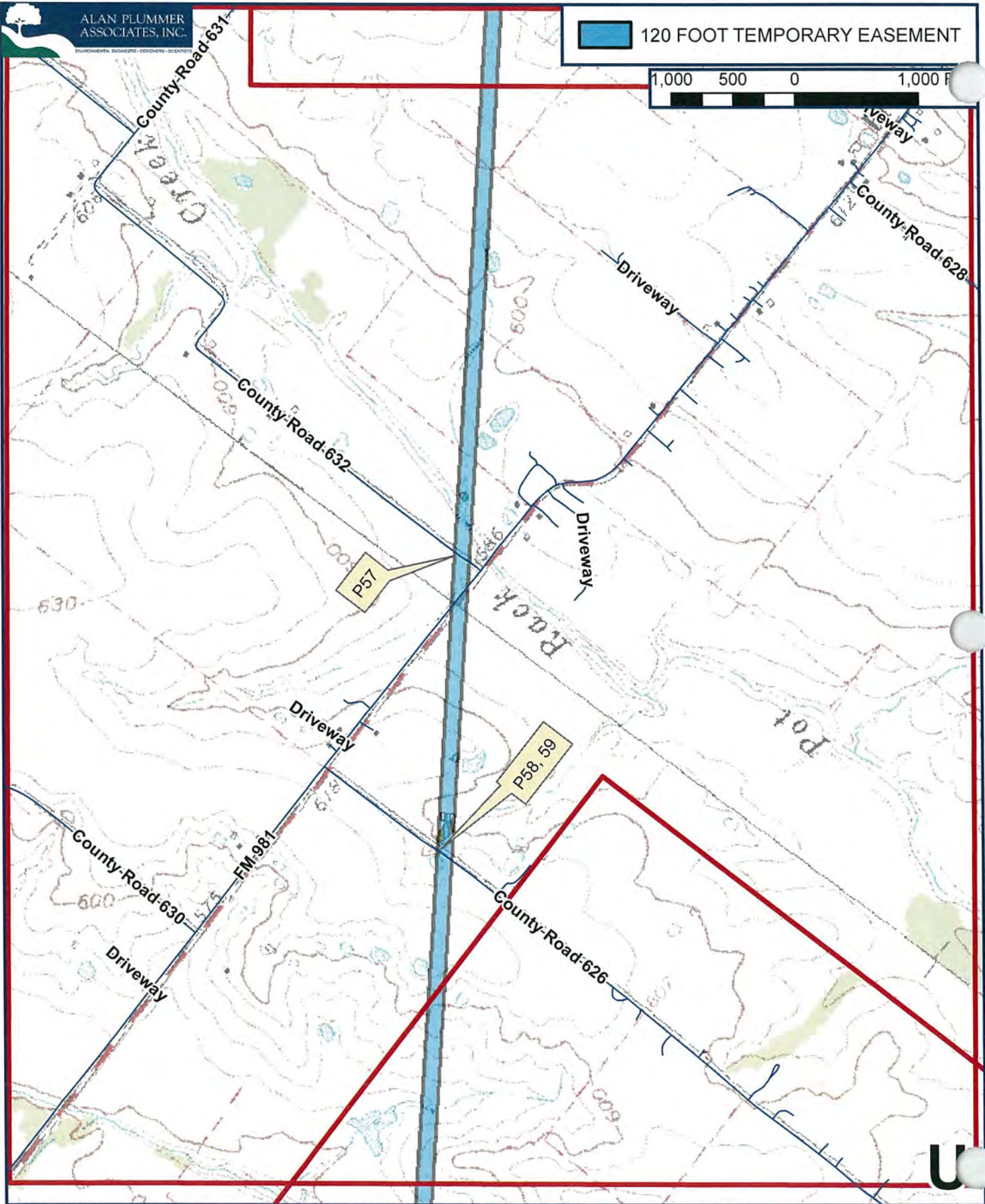

B-22

FIELD INVESTIGATION PHOTOGRAPHS

FIGURE 22 OF 24
MARCH 24, 2008

PROPOSED BOIS D'ARC RESERVOIR - RAW WATER TRANSMISSION PIPELINE

120 FOOT TEMPORARY EASEMENT

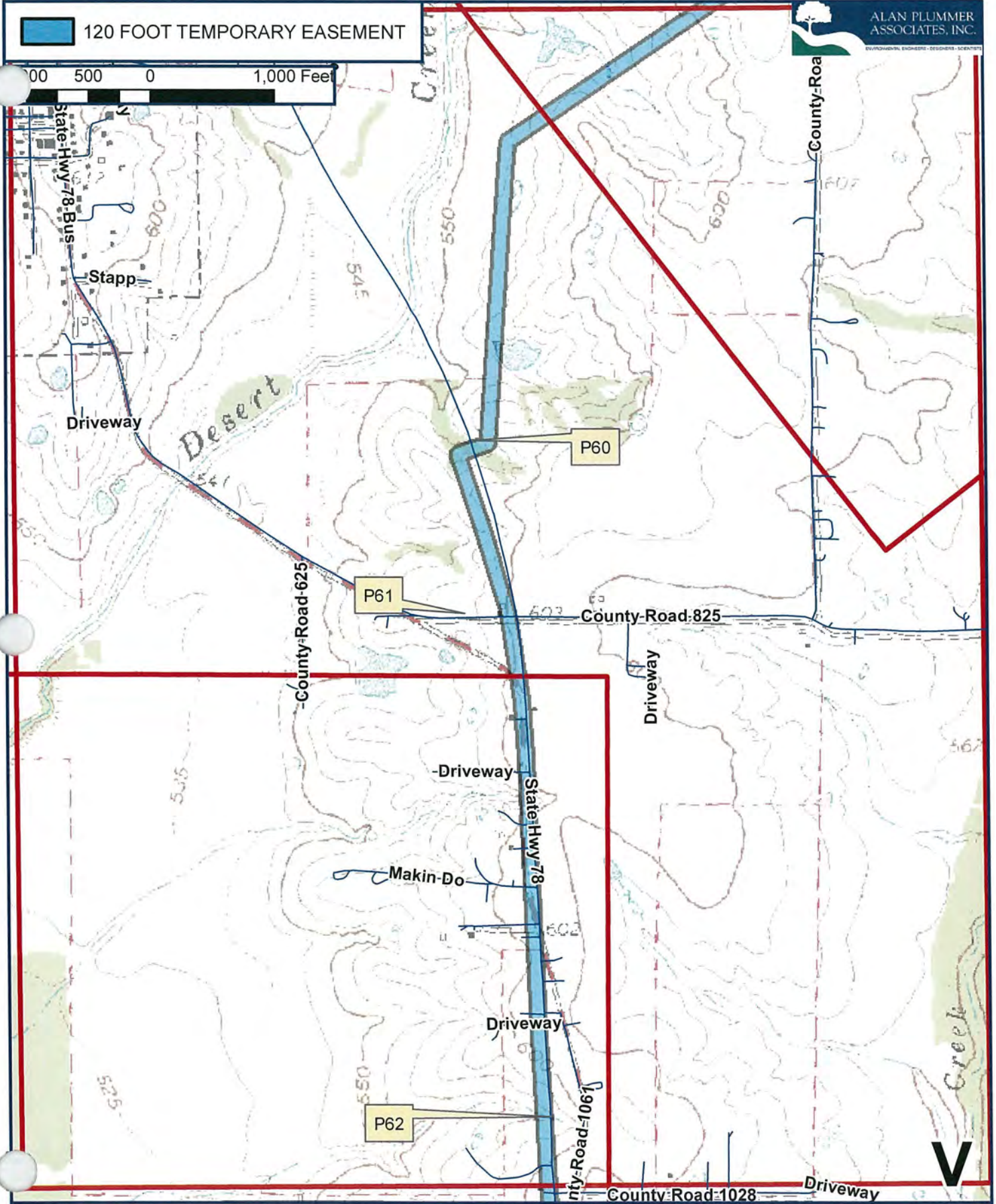

B-23

FIELD INVESTIGATION PHOTOGRAPHS

FIGURE 23 OF 24
MARCH 24, 2008

PROPOSED BOIS D'ARC RESERVOIR - RAW WATER TRANSMISSION PIPELINE

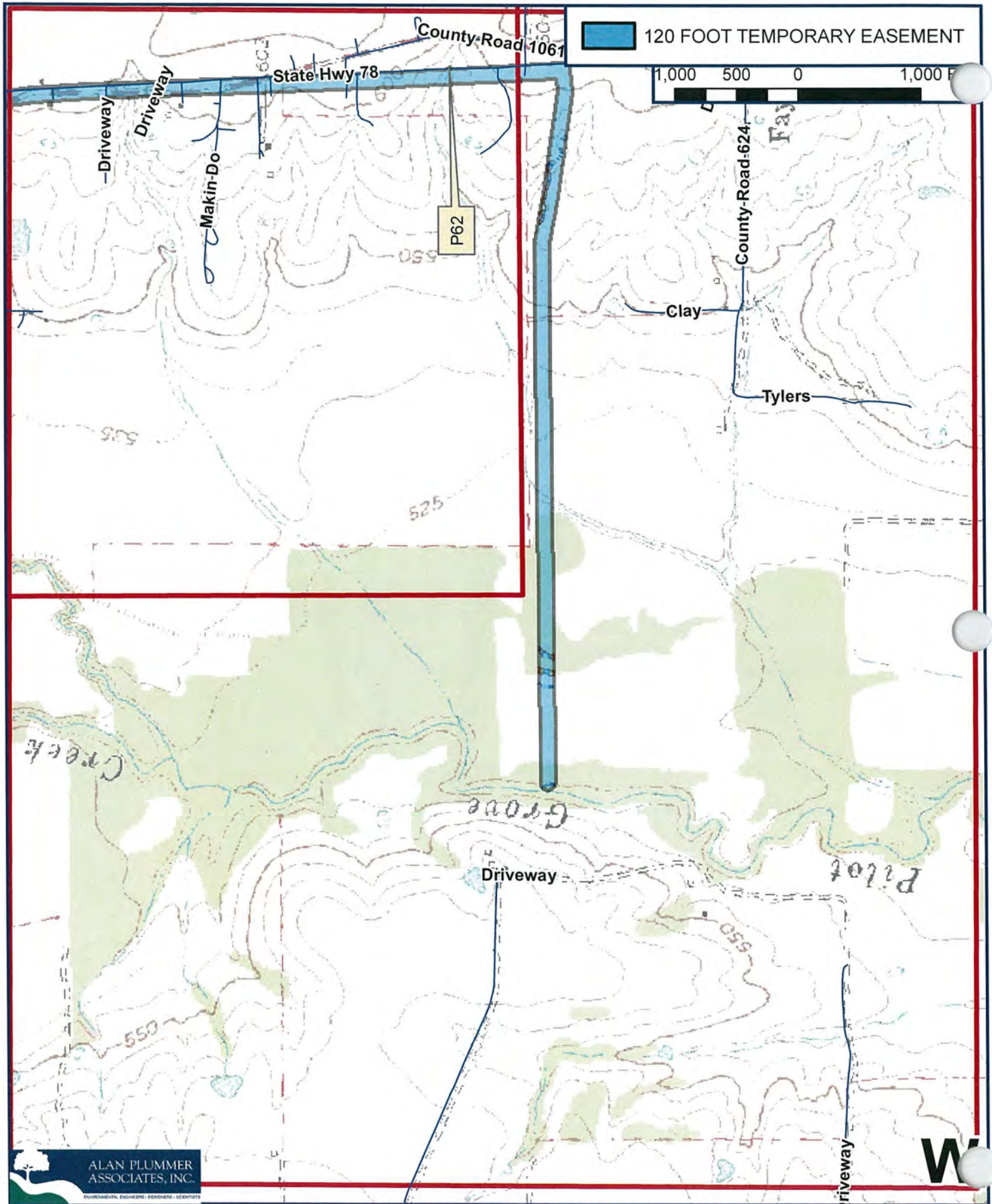

B-24

FIELD INVESTIGATION PHOTOGRAPHS

FIGURE 24 OF 24
MARCH 24, 2008

PROPOSED BOIS D'ARC RESERVOIR - RAW WATER TRANSMISSION PIPELINE



P1. Unnamed tributary to Ward Creek, looking upstream east.



P2. Unnamed tributary to Ward Creek, looking downstream west at pipeline crossing.



P3. Unnamed tributary to Bois d'Arc Creek, looking downstream east towards the pipeline crossing.



P4. Unnamed tributary to Bois d'Arc Creek, looking upstream west.



P5. Powerline right of way where pipeline would follow, looking east.



P6. Pettigrew Branch, looking downstream southeast. Pipeline crosses the stream approximately 1 mile downstream.



P7. Pipeline ROW at crossing of U.S. Highway 82, looking north.



P8. Pipeline ROW at crossing of U.S. Highway 82, looking east.



P9. Pipeline ROW at FM 1743 crossing, looking southwest.



P10. Pipeline ROW at FM 1743 crossing, looking east.



P11. Unnamed tributary to Cottonwood Creek at pipeline crossing, looking upstream northeast.



P12. Pot Creek headwater.

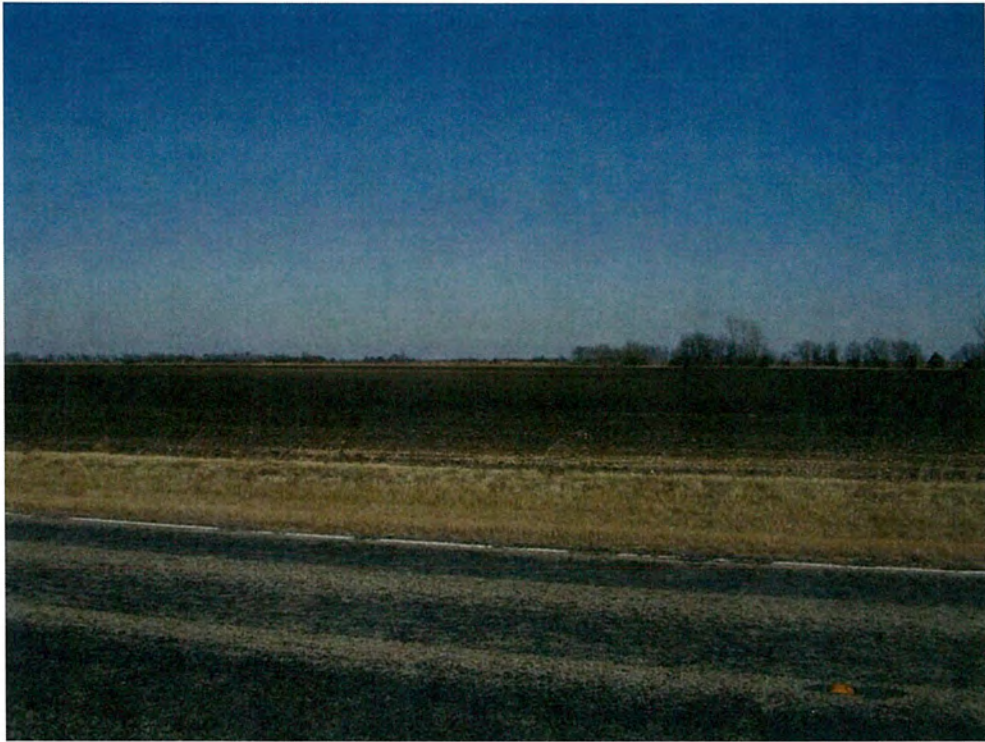

P13. Pipeline crossing of FM 271, looking northeast.



P14. Pipeline crossing of FM 271, looking southwest.



P15. Pipeline crossing of County Road 3120, looking east at gas pipeline marker.



P16. Pipeline crossing of County Road 3120, looking east.



P17. Pipeline crossing of County Road 3120, looking west.



P18. Pipeline at County Road 3115, looking east.



P19. Pipeline at County Road 3115, looking south.



P20. Road drainage off of FM 3115 looking east. The drainage had no identifiable OHWM.



P21. Road drainage off of FM 1552 looking north. The drainage had no identifiable OHWM.



P22. Unnamed tributary to Loring Creek, looking south.



P23. Loring Creek, looking south.



P24. Loring Creek, looking south.



P25. State Highway 78 and County Road 4815 intersection, looking southwest.



P26. Unnamed tributary to Mustang Creek, looking southwest.



P27. Mustang Creek, looking south.



P28. Unnamed tributary to Mustang Creek, looking downstream southeast.



P29. South Sulfur River, looking downstream south.



P30. Drainage to South Sulfur River, looking downstream east.



P31. Unnamed tributary to South Sulfur River, looking downstream east.



P32. Culverted crossing of an Unnamed tributary to South Sulfur River, looking west.



P33. Unnamed tributary to South Sulfur River, looking upstream north.



P34. Unnamed tributary to South Sulfur River, looking downstream south.



P35. Pipeline ROW, looking southwest.



P36. Unnamed tributary to Bear Creek, looking upstream north.



P37. Lee Creek, looking upstream north.



P38. Pipeline ROW following a power line ROW, looking northeast.



P39. Pipeline ROW following a power line ROW, looking southwest.



P40. Impounded unnamed tributary to Lee Creek, looking upstream north.



P41. Pipeline ROW following a power line ROW, looking northeast.



P42. Pipeline ROW following a power line ROW, looking southwest.



P43. Pipe crossing at FM 881 and County Road 5020 intersection, looking northeast.



P44. Head water of unnamed tributary to Bear Creek at pipeline crossing, looking upstream northwest.



P45. Head water of unnamed tributary to Bear Creek at pipeline crossing, looking downstream southeast.



P46. Pipeline ROW following a power line ROW, looking northeast.



P47. Pipeline ROW following a power line ROW, looking southwest.



P48. Bear Creek, looking downstream south towards the pipeline crossing.



P49. Unnamed tributary to Bear Creek, looking downstream southeast.



P50. Impounded tributaries and potential wetlands at pipeline crossing, looking northeast.



P51. Pipeline ROW following a power line ROW, looking northeast.



P52. Indian Creek, looking upstream north towards pipeline crossing.



P53. Unnamed tributary at pipeline crossing, looking downstream southeast.



P54. Unnamed tributary at pipeline crossing, looking downstream southeast.



P55. Unnamed tributary to Indian Creek, looking downstream southeast.



P56. Pipeline ROW following a power line ROW, looking southwest.



P57. Pipeline ROW following a power line ROW, looking northeast.



P58. Pipeline ROW following a power line ROW, looking southwest.



P59. Pipeline ROW following a power line ROW, looking northeast.



P60. Pipeline ROW following a gas pipeline ROW, looking northeast.



P61. Impoundment west of pipeline ROW where pipeline would parallel State Highway 78, looking west.



P62. Impoundment west of pipeline ROW where pipeline would parallel State Highway 78, looking west.

APPENDIX C
SOIL SERIES DESCRIPTIONS



ALAN PLUMMER
ASSOCIATES, INC.

ENVIRONMENTAL ENGINEERS • DESIGNERS • SCIENTISTS

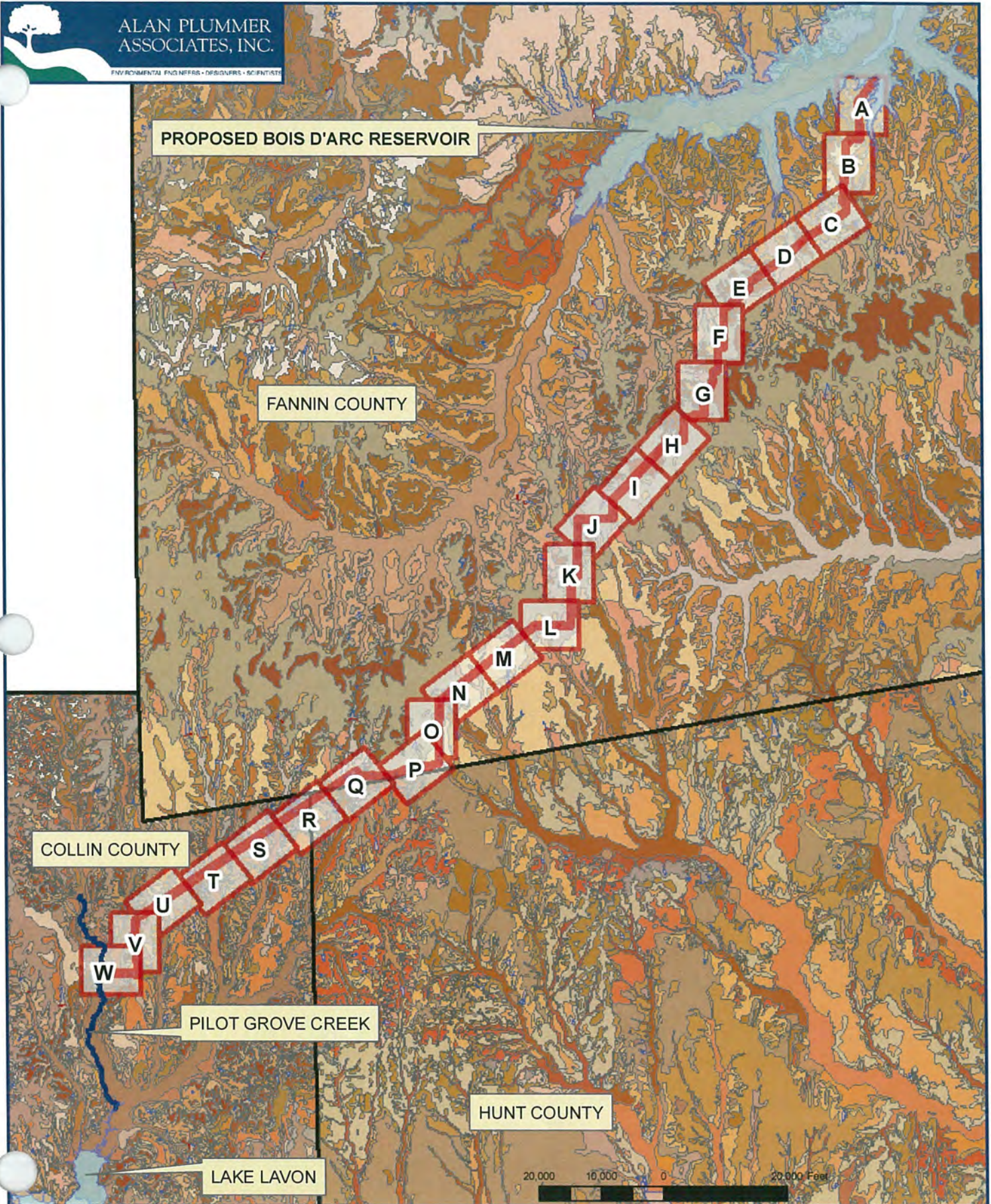

C-1

SOIL MAP UNIT PLATE LOCATIONS

PROPOSED BOIS D'ARC RESERVOIR - RAW WATER TRANSMISSION PIPELINE ■

FIGURE 50 OF 73
MARCH 25, 2008



ALAN PLUMMER
ASSOCIATES, INC.

ENVIRONMENTAL ENGINEERS • DESIGNERS • SCIENTISTS



FIGURE 2 OF 24
MARCH 24, 2008

 LISTED HYDRIC SOIL

A

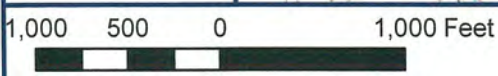

FIGURE C-2
SOIL MAP UNITS
PROPOSED BOIS D'ARC RESERVOIR - RAW WATER TRANSMISSION PIPELINE

LISTED HYDRIC SOIL

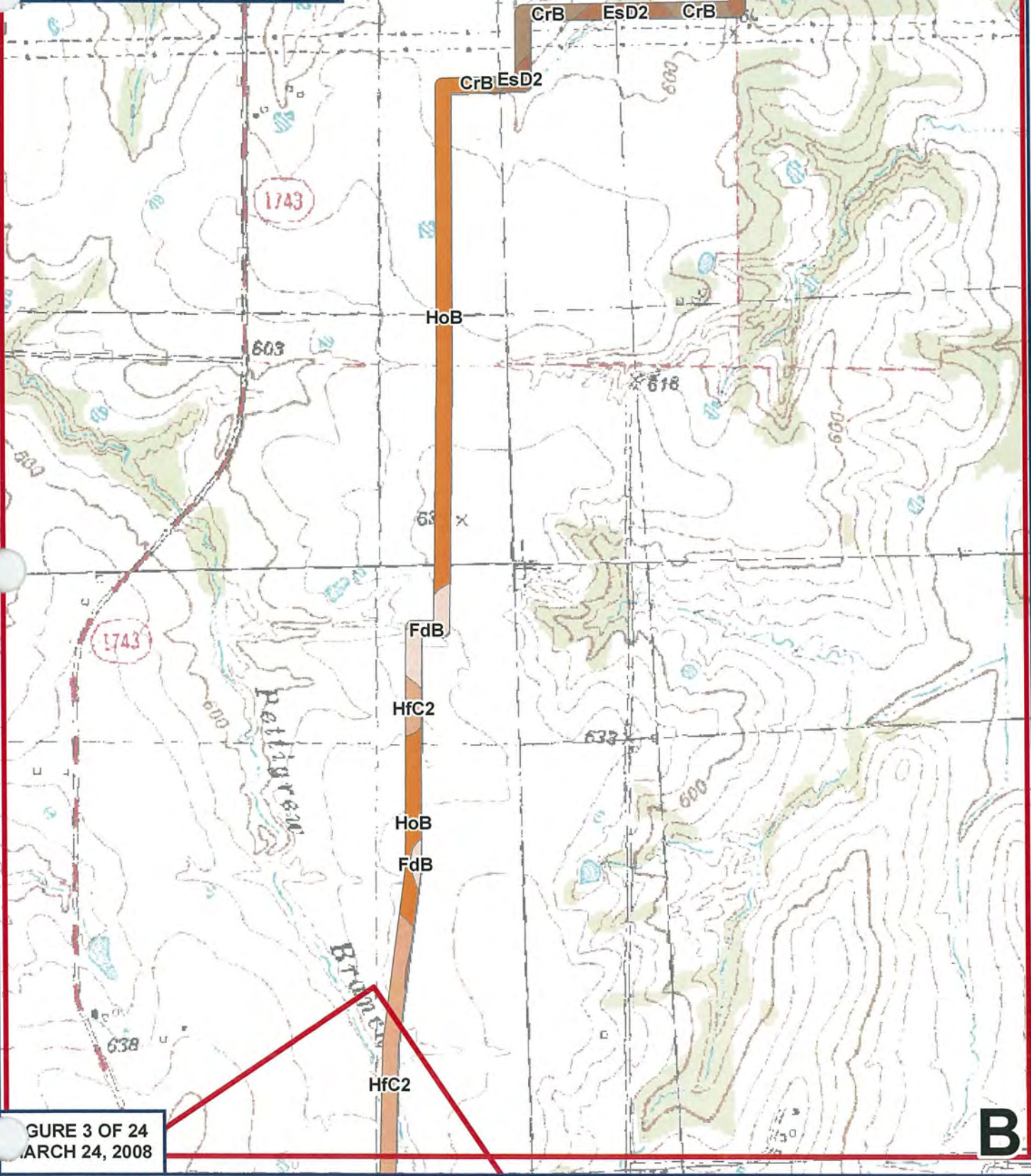

FIGURE 3 OF 24
 MARCH 24, 2008

B

**FIGURE C-3
 SOIL MAP UNITS
 PROPOSED BOIS D'ARC RESERVOIR - RAW WATER TRANSMISSION PIPELINE**

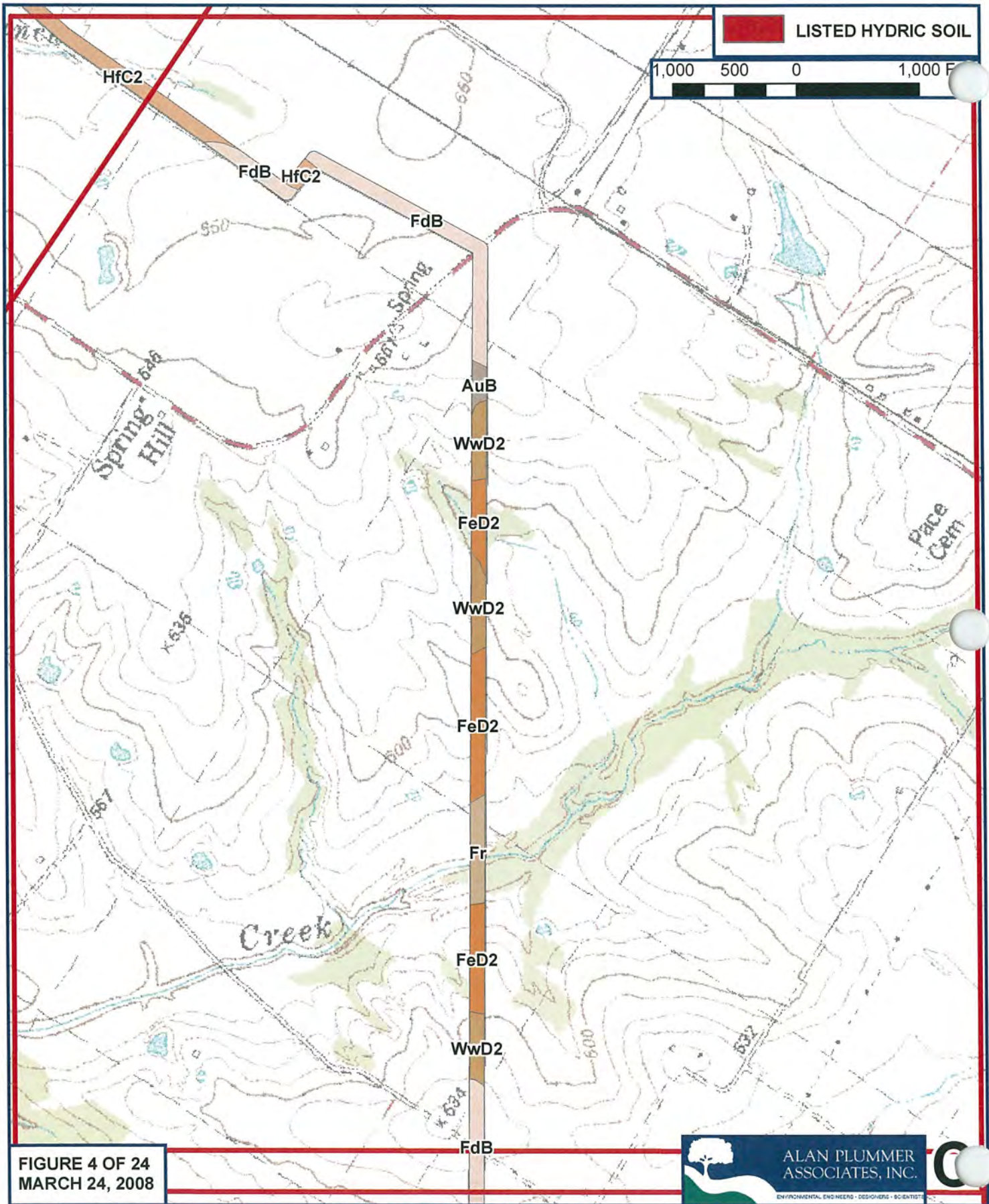

FIGURE C-4
SOIL MAP UNITS
PROPOSED BOIS D'ARC RESERVOIR - RAW WATER TRANSMISSION PIPELINE

LISTED HYDRIC SOIL

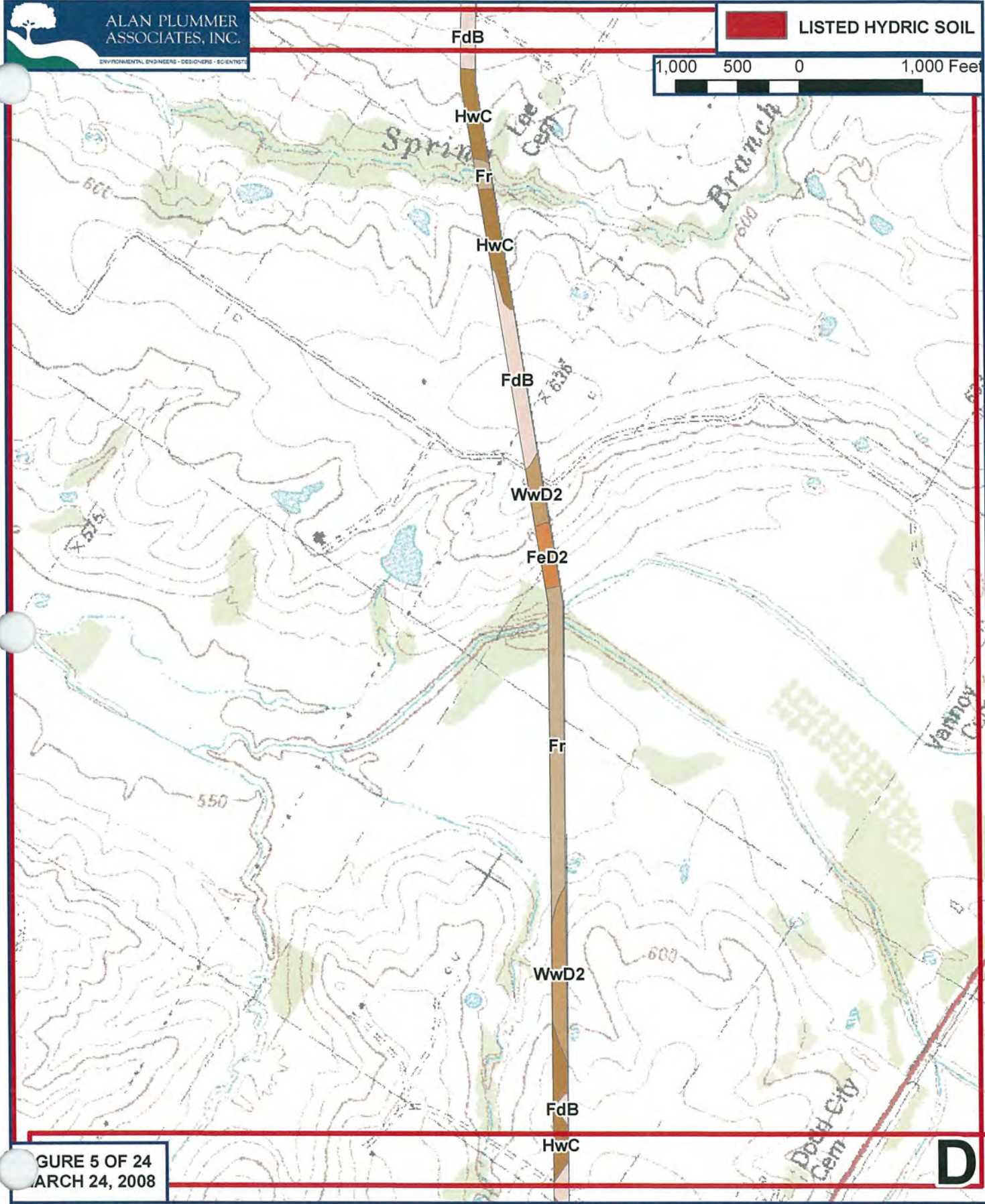

FIGURE 5 OF 24
MARCH 24, 2008

D

FIGURE C-5
SOIL MAP UNITS
PROPOSED BOIS D'ARC RESERVOIR - RAW WATER TRANSMISSION PIPELINE

LISTED HYDRIC SOIL

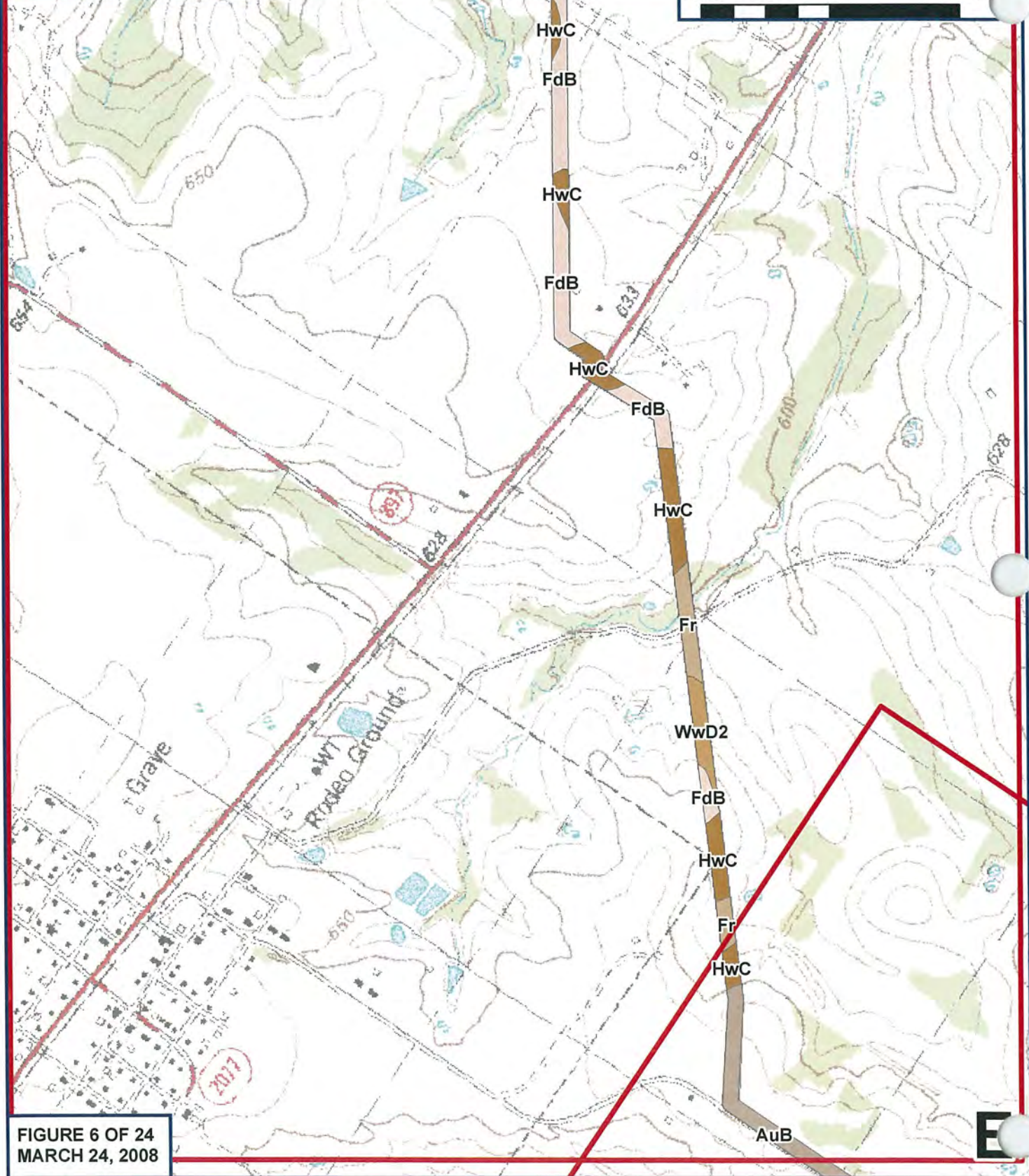
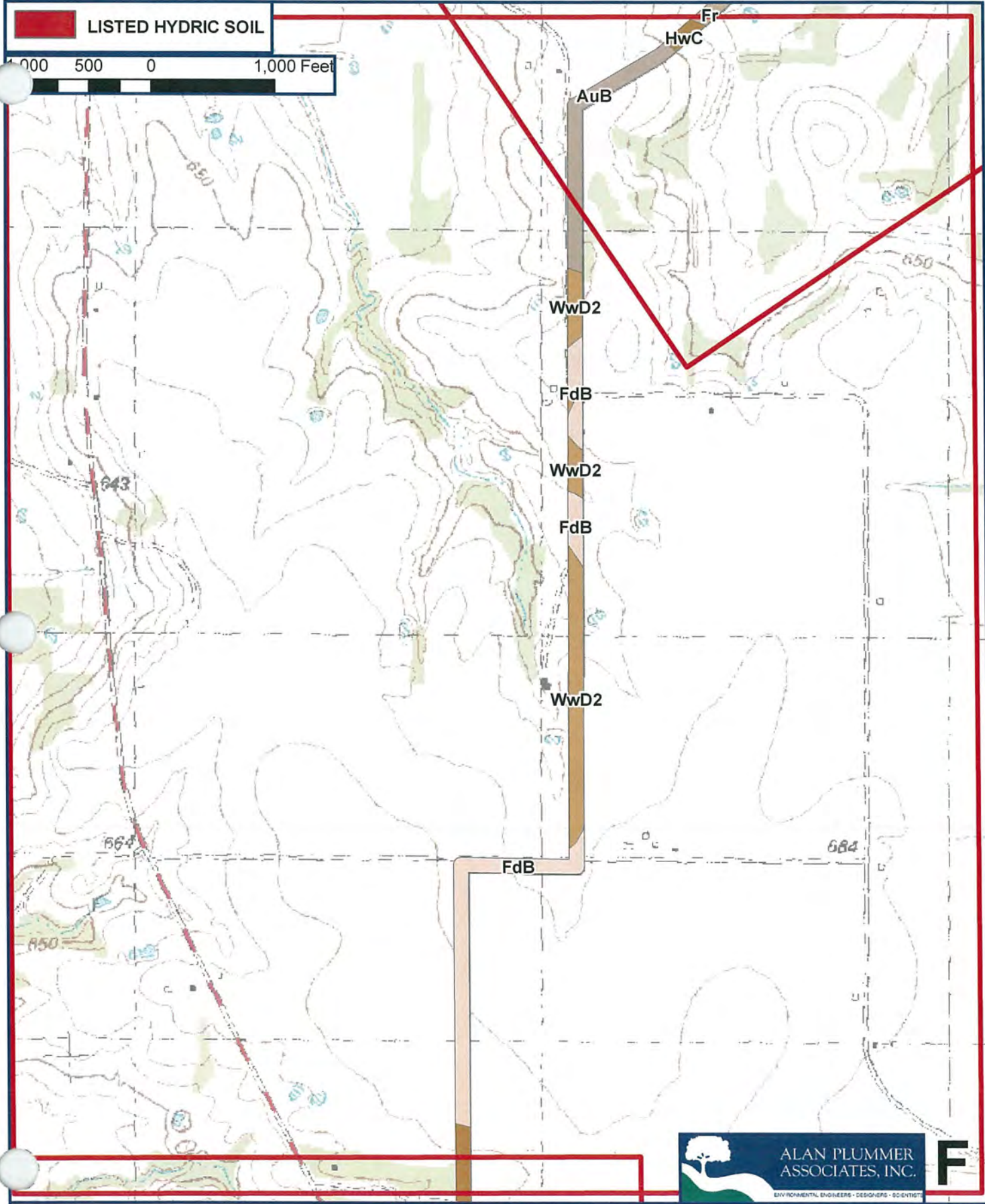

FIGURE 6 OF 24
MARCH 24, 2008

FIGURE C-6
SOIL MAP UNITS
PROPOSED BOIS D'ARC RESERVOIR - RAW WATER TRANSMISSION PIPELINE



**FIGURE C-7
SOIL MAP UNITS
PROPOSED BOIS D'ARC RESERVOIR - RAW WATER TRANSMISSION PIPELINE**

FIGURE 7 OF 24
MARCH 24, 2008

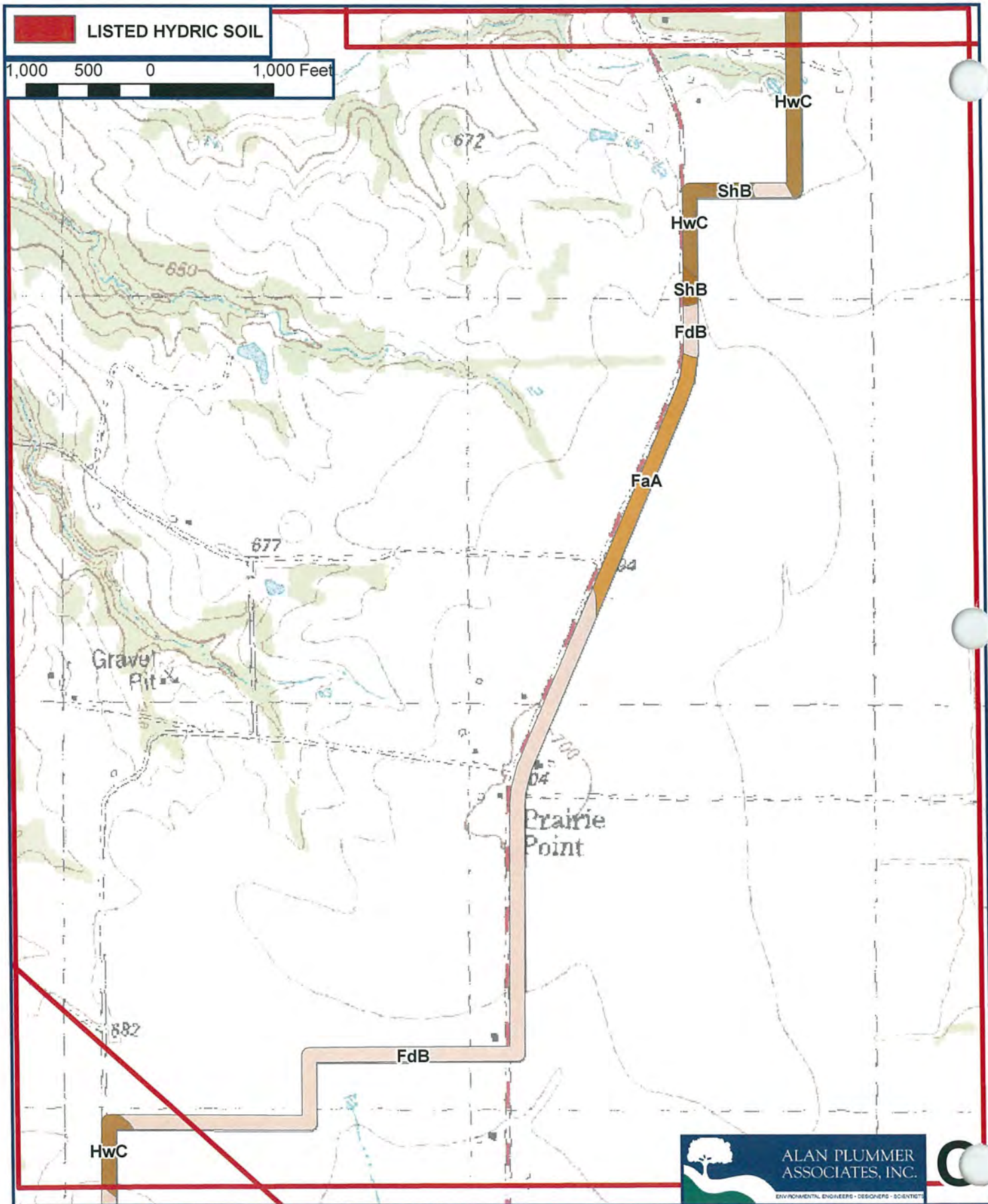

**FIGURE C-8
SOIL MAP UNITS**

LISTED HYDRIC SOIL

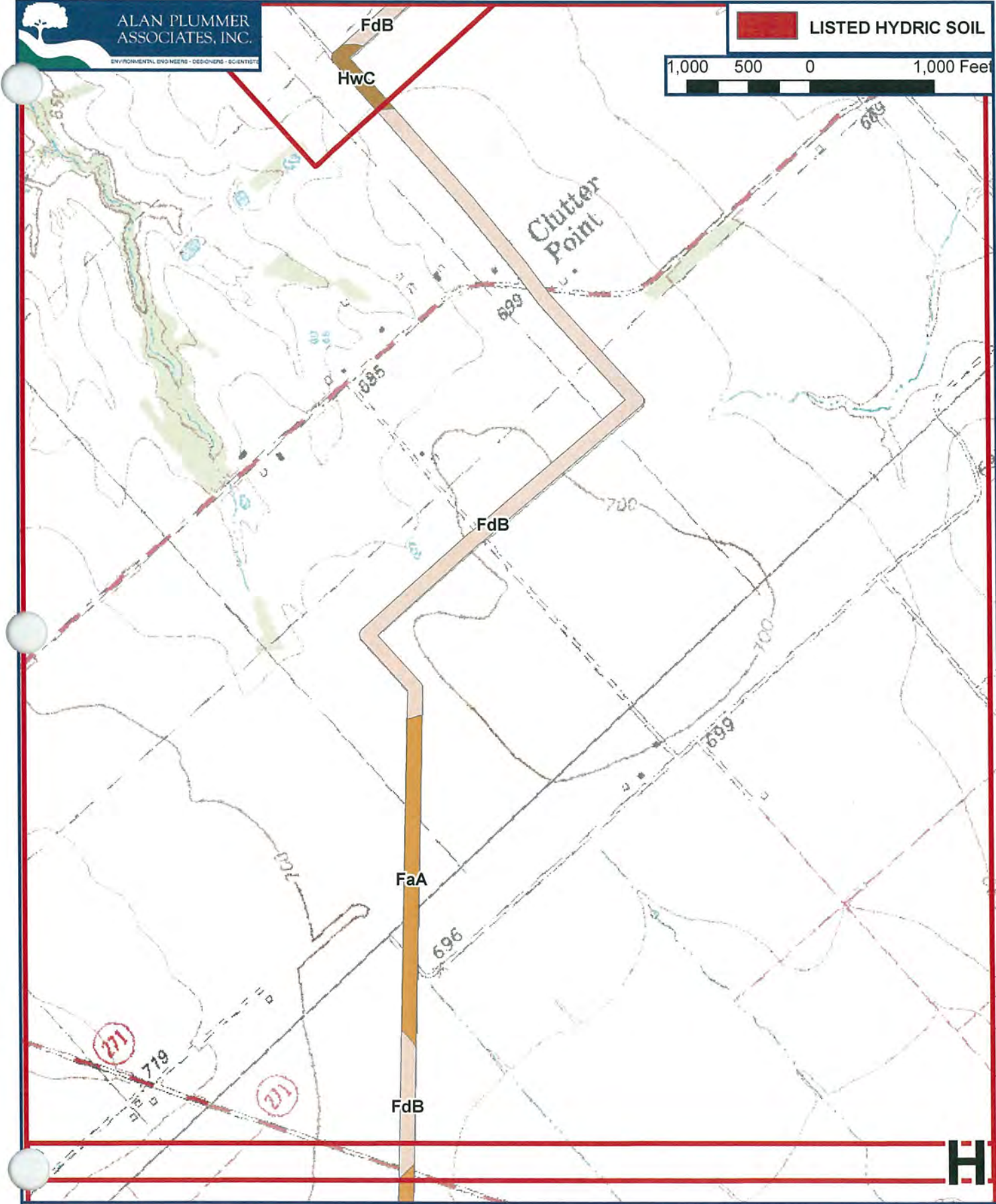
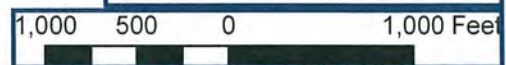

**FIGURE C-9
SOIL MAP UNITS
PROPOSED BOIS D'ARC RESERVOIR - RAW WATER TRANSMISSION PIPELINE**

LISTED HYDRIC SOIL

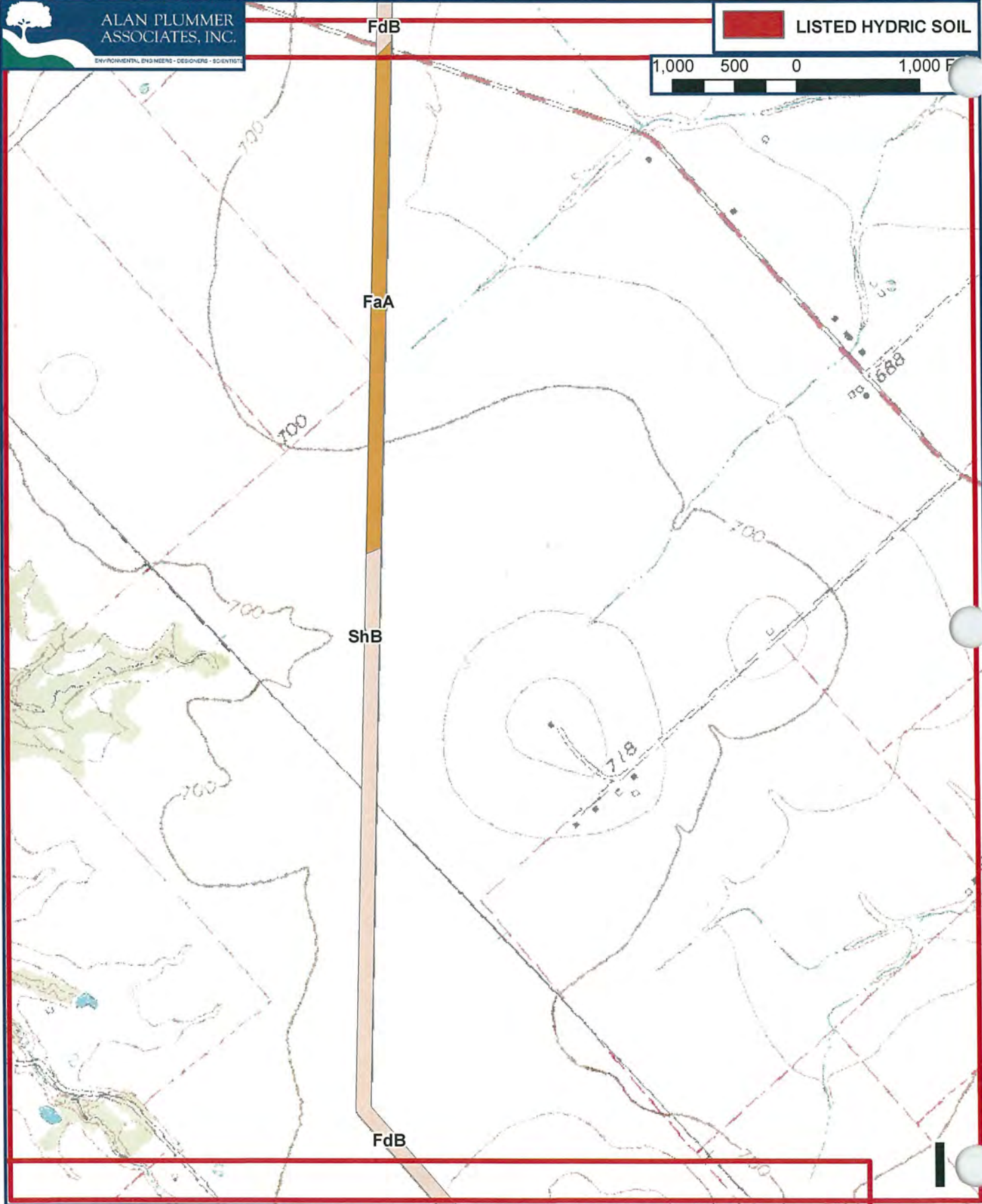

FIGURE C-10
SOIL MAP UNITS

LISTED HYDRIC SOIL

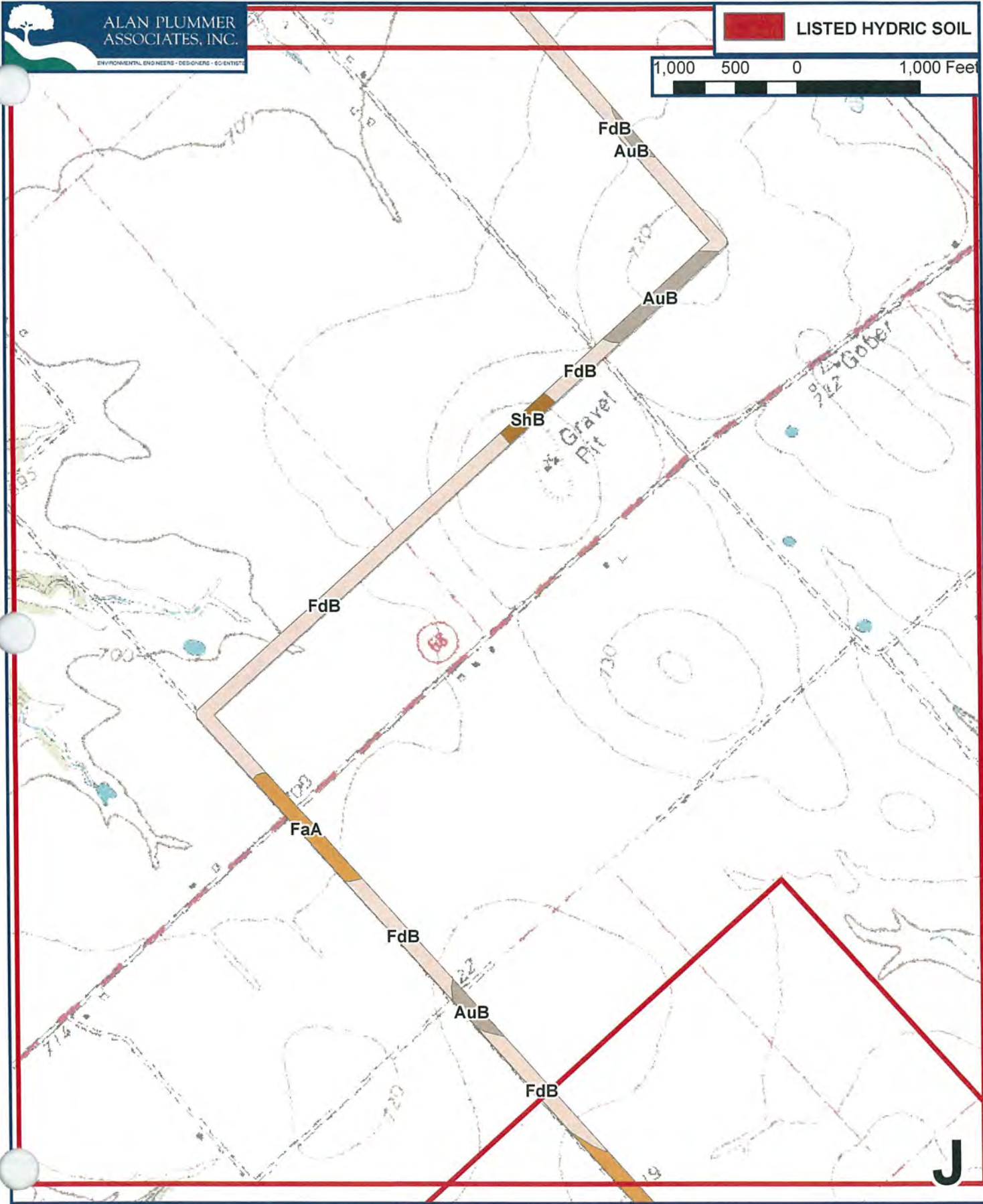
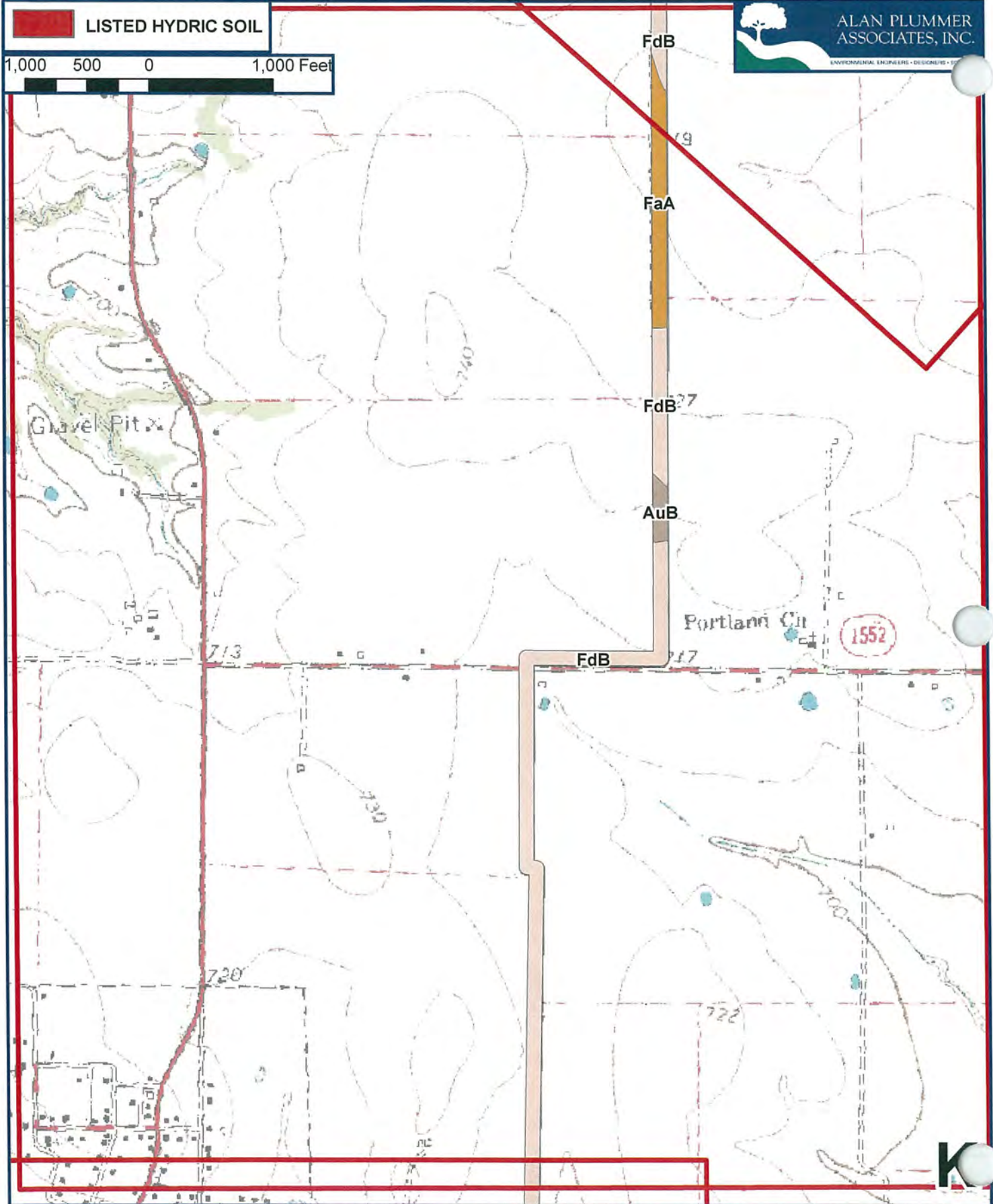

FIGURE C-11
SOIL MAP UNITS



**FIGURE C-12
SOIL MAP UNITS**

FIGURE 12 OF 24
MARCH 24, 2008

PROPOSED BOIS D'ARC RESERVOIR - RAW WATER TRANSMISSION PIPELINE ■

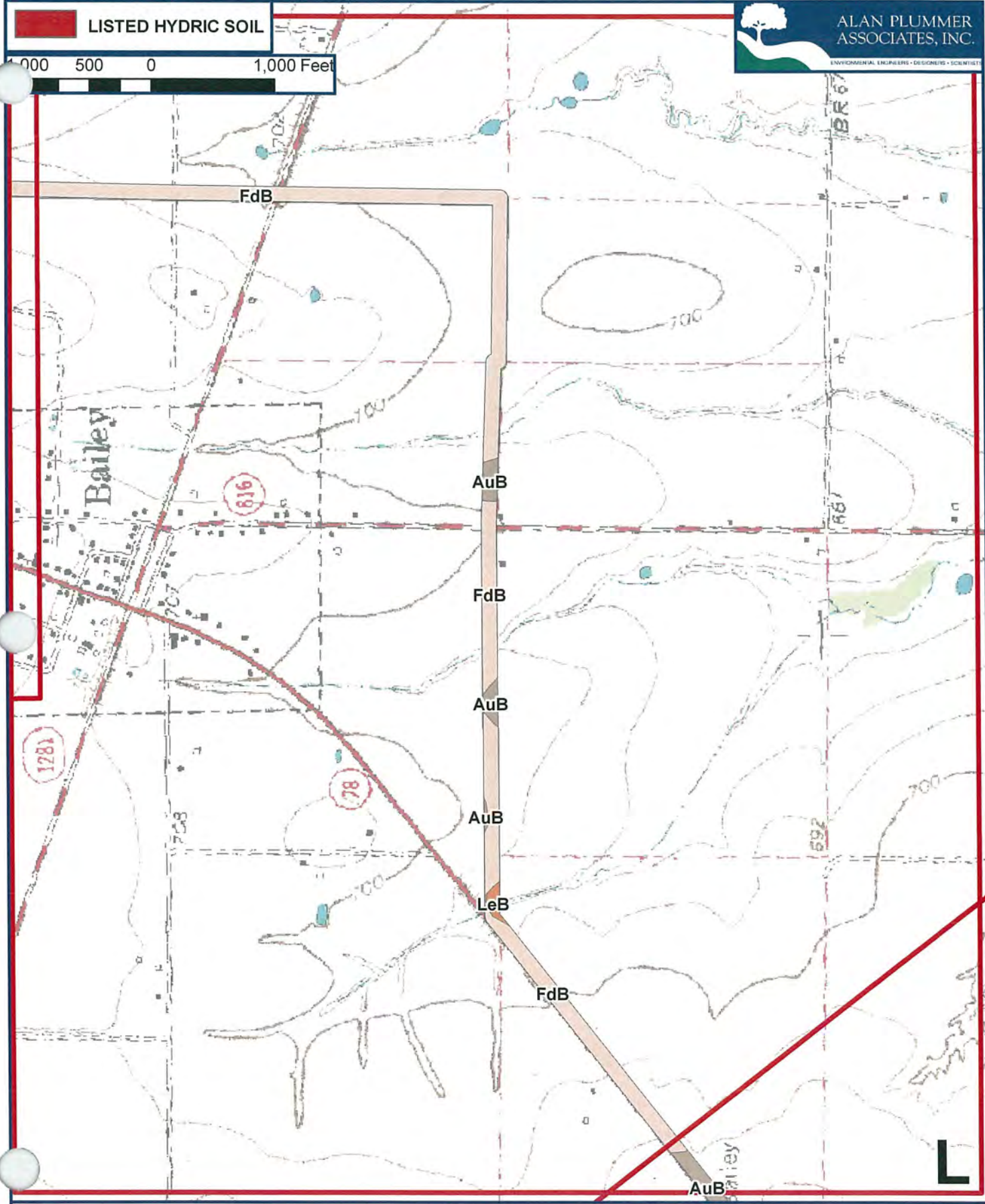
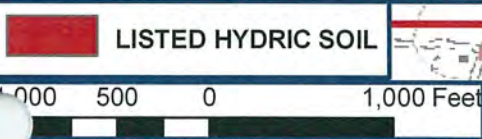
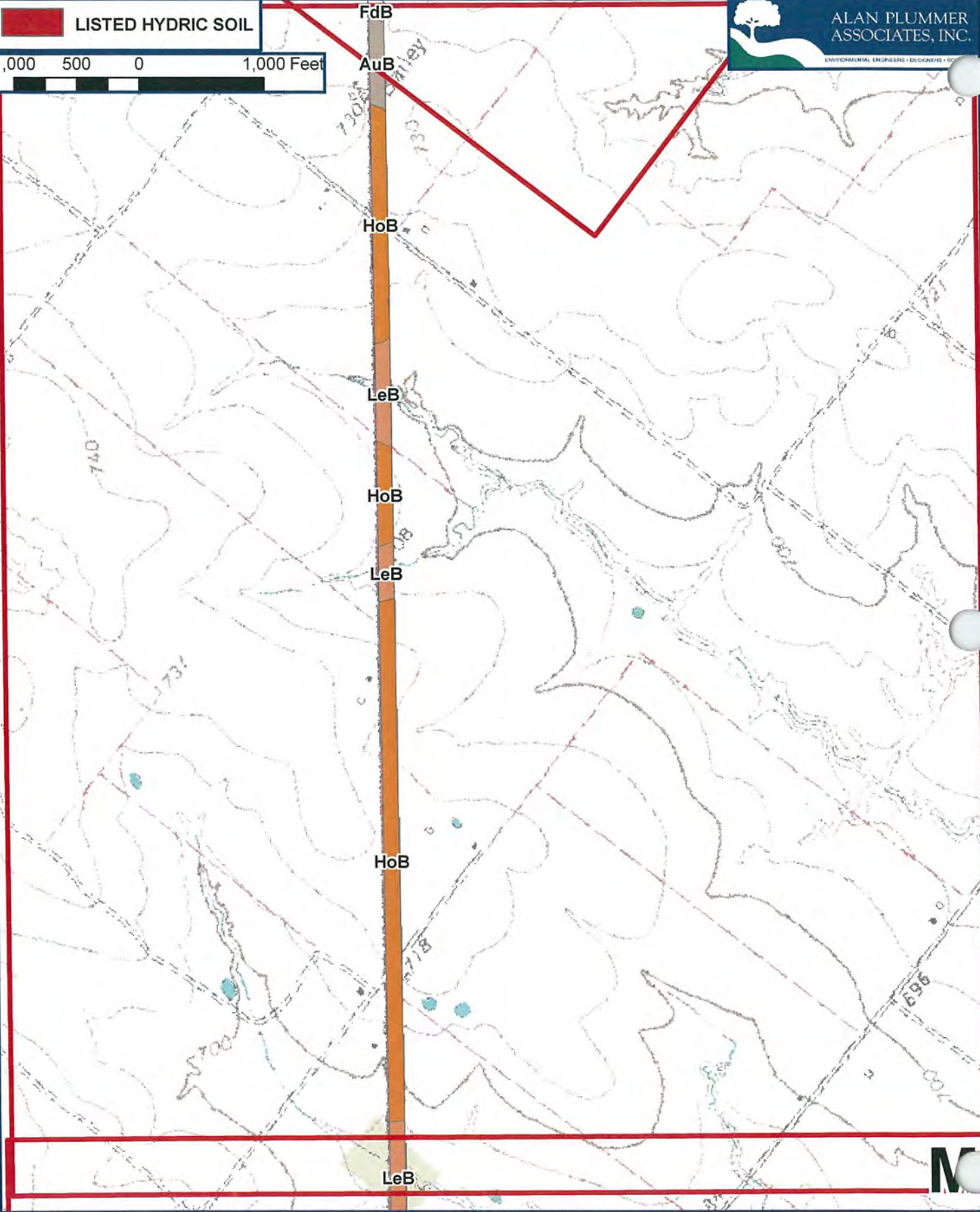

FIGURE C-13
 SOIL MAP UNITS

LISTED HYDRIC SOIL

1,000 500 0 1,000 Feet



**FIGURE C-14
SOIL MAP UNITS**

FIGURE 14 OF 24
MARCH 24, 2008

PROPOSED BOIS D'ARC RESERVOIR - RAW WATER TRANSMISSION PIPELINE

LISTED HYDRIC SOIL

1,000 500 0 1,000 Feet

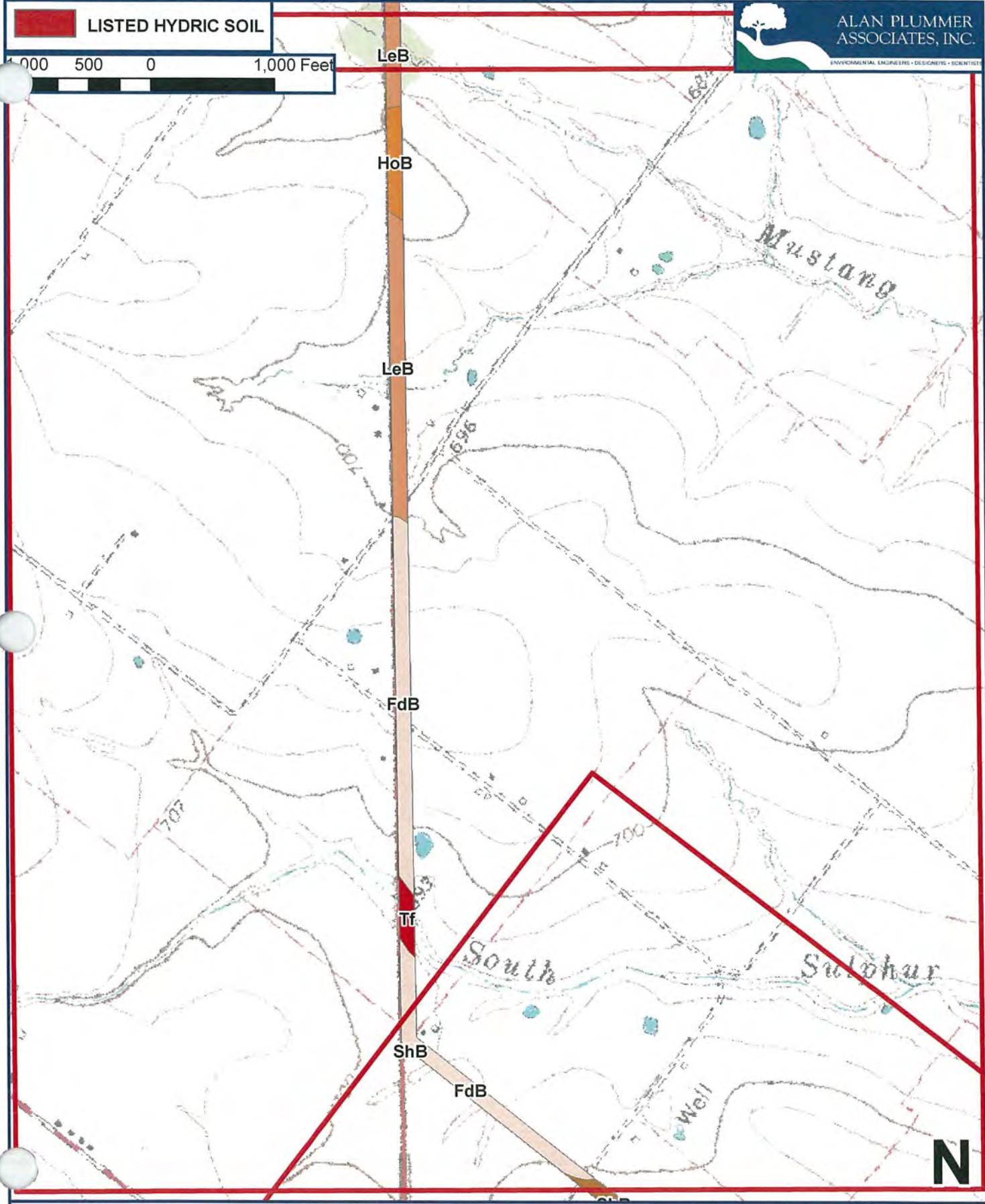

**FIGURE C-15
 SOIL MAP UNITS**

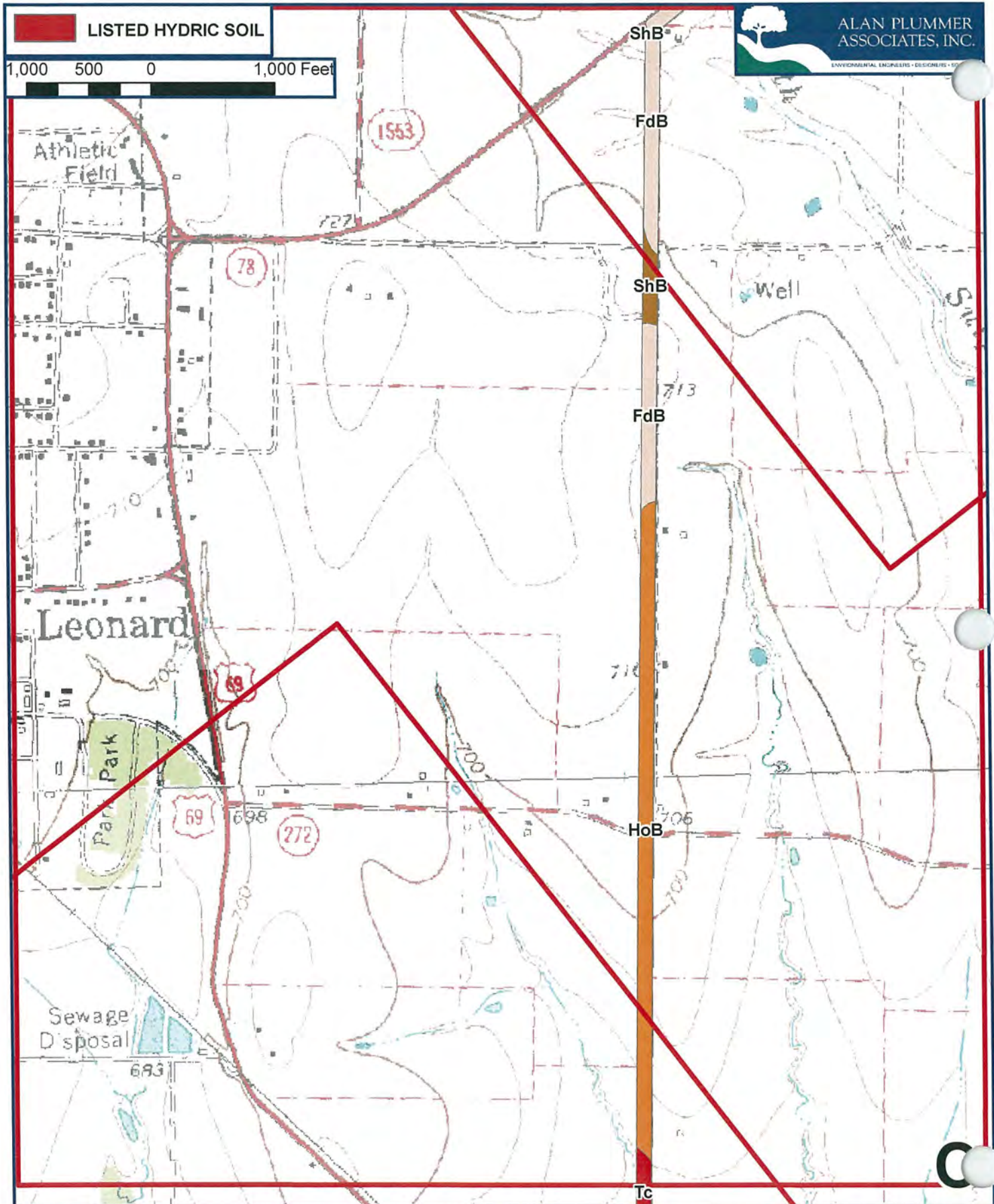

**FIGURE C-16
SOIL MAP UNITS**

FIGURE 16 OF 24
MARCH 24, 2008

PROPOSED BOIS D'ARC RESERVOIR - RAW WATER TRANSMISSION PIPELINE ■

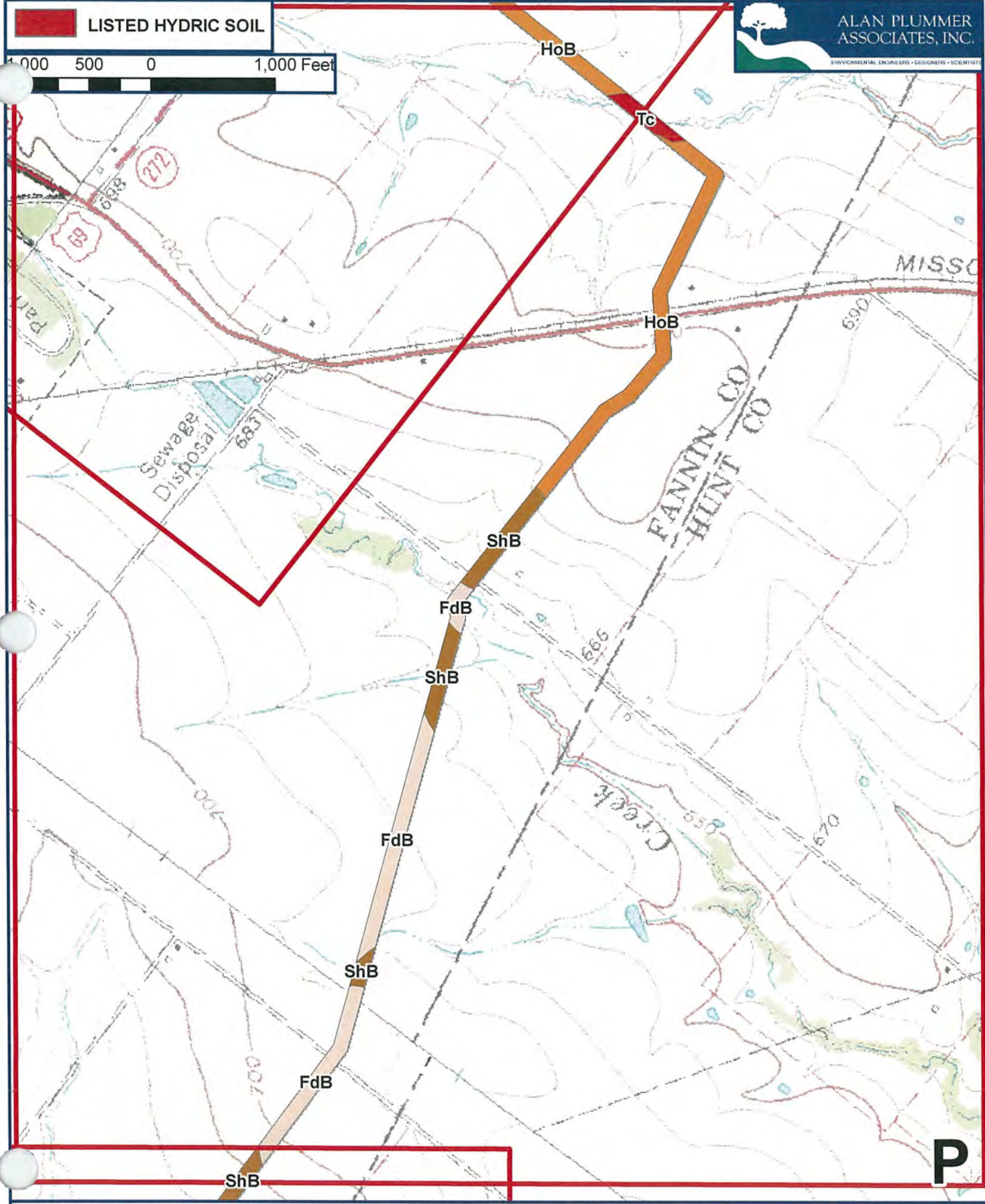
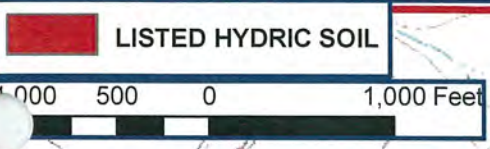
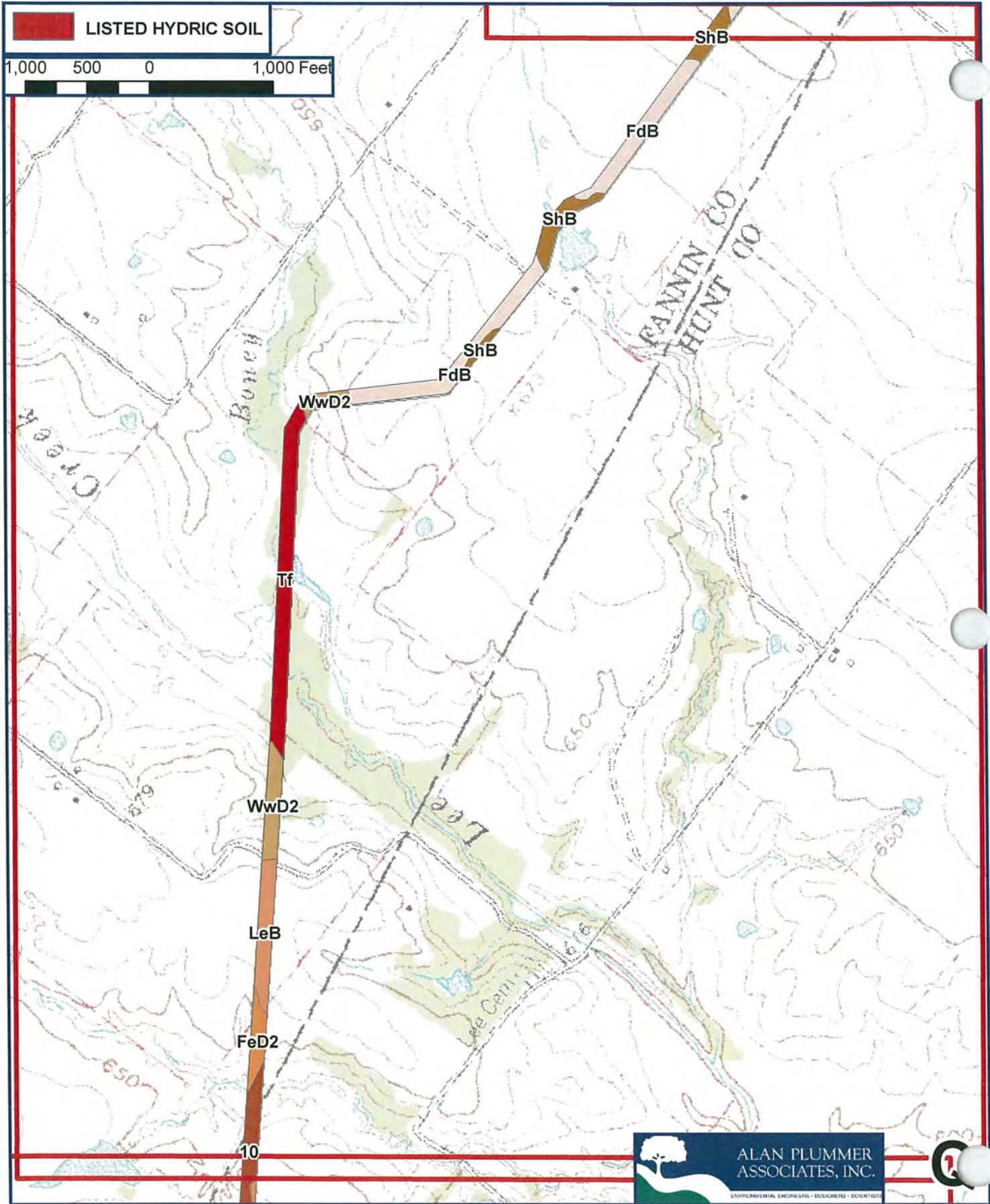

FIGURE C-17
 SOIL MAP UNITS

FIGURE 17 OF 24
 MARCH 24, 2008

PROPOSED BOIS D'ARC RESERVOIR - RAW WATER TRANSMISSION PIPELINE



**FIGURE C-18
SOIL MAP UNITS**

FIGURE 18 OF 24
MARCH 24, 2008

PROPOSED BOIS D'ARC RESERVOIR - RAW WATER TRANSMISSION PIPELINE

LISTED HYDRIC SOIL

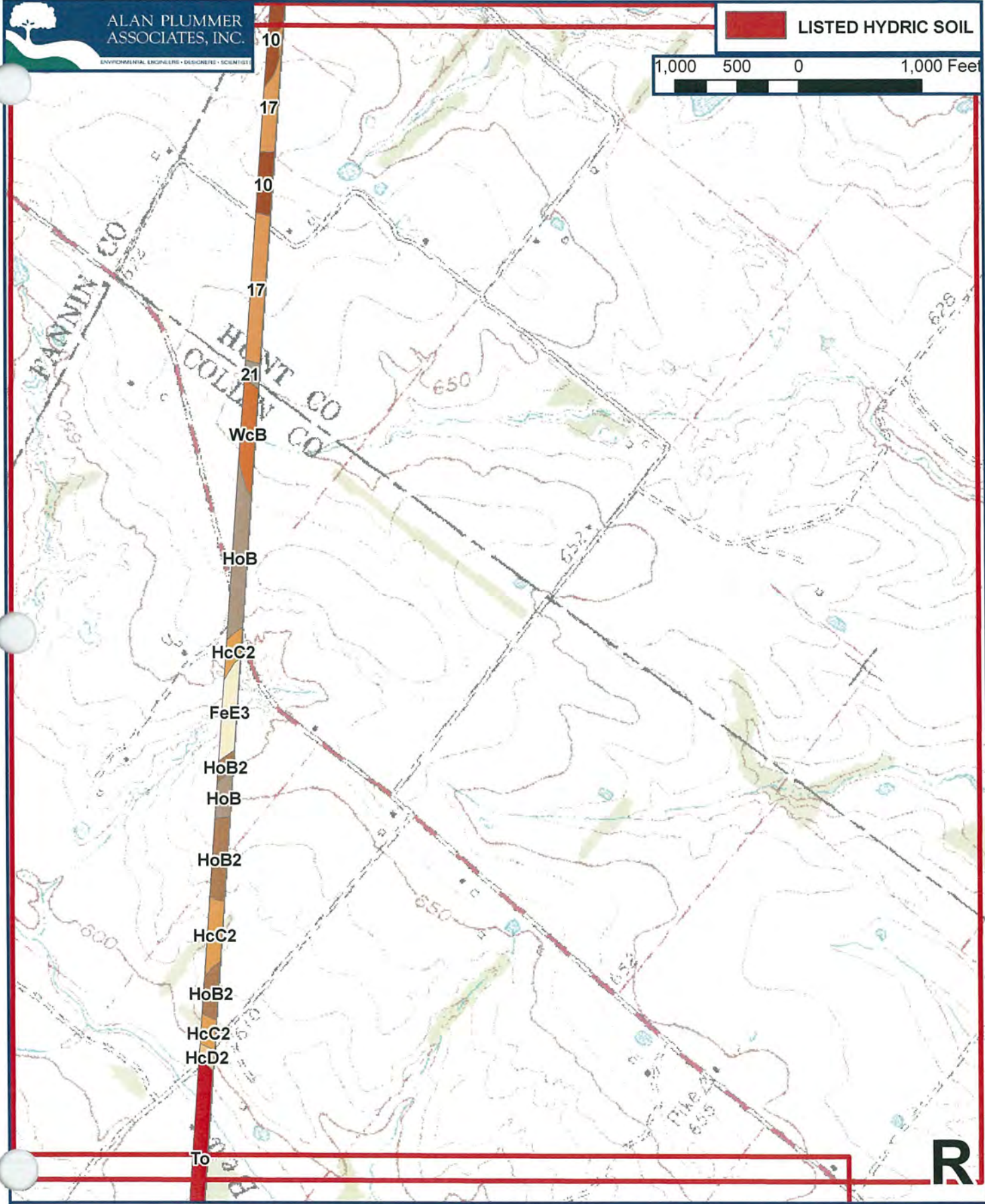

FIGURE C-19
 SOIL MAP UNITS



LISTED HYDRIC SOIL

1,000 500 0 1,000 F

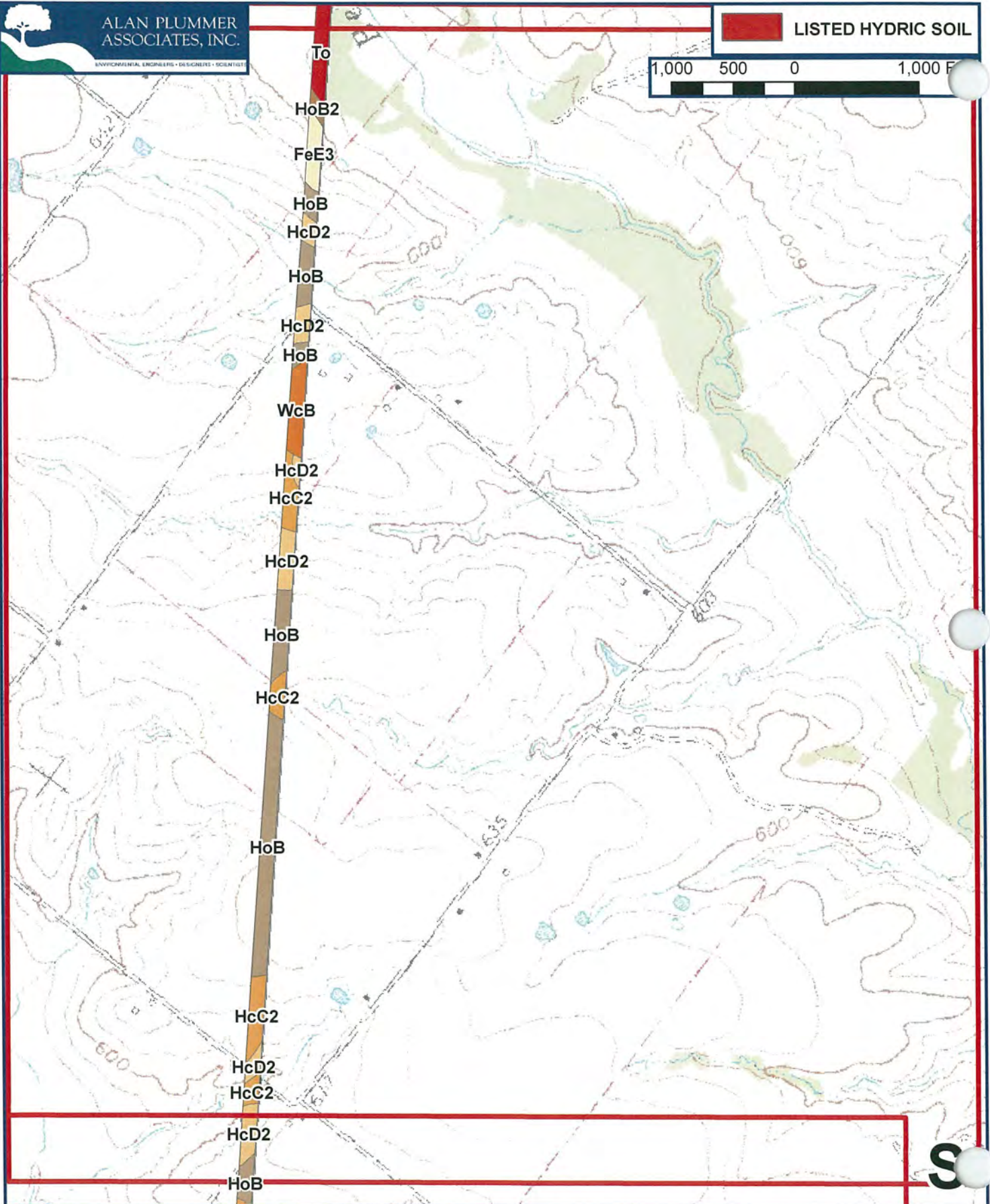
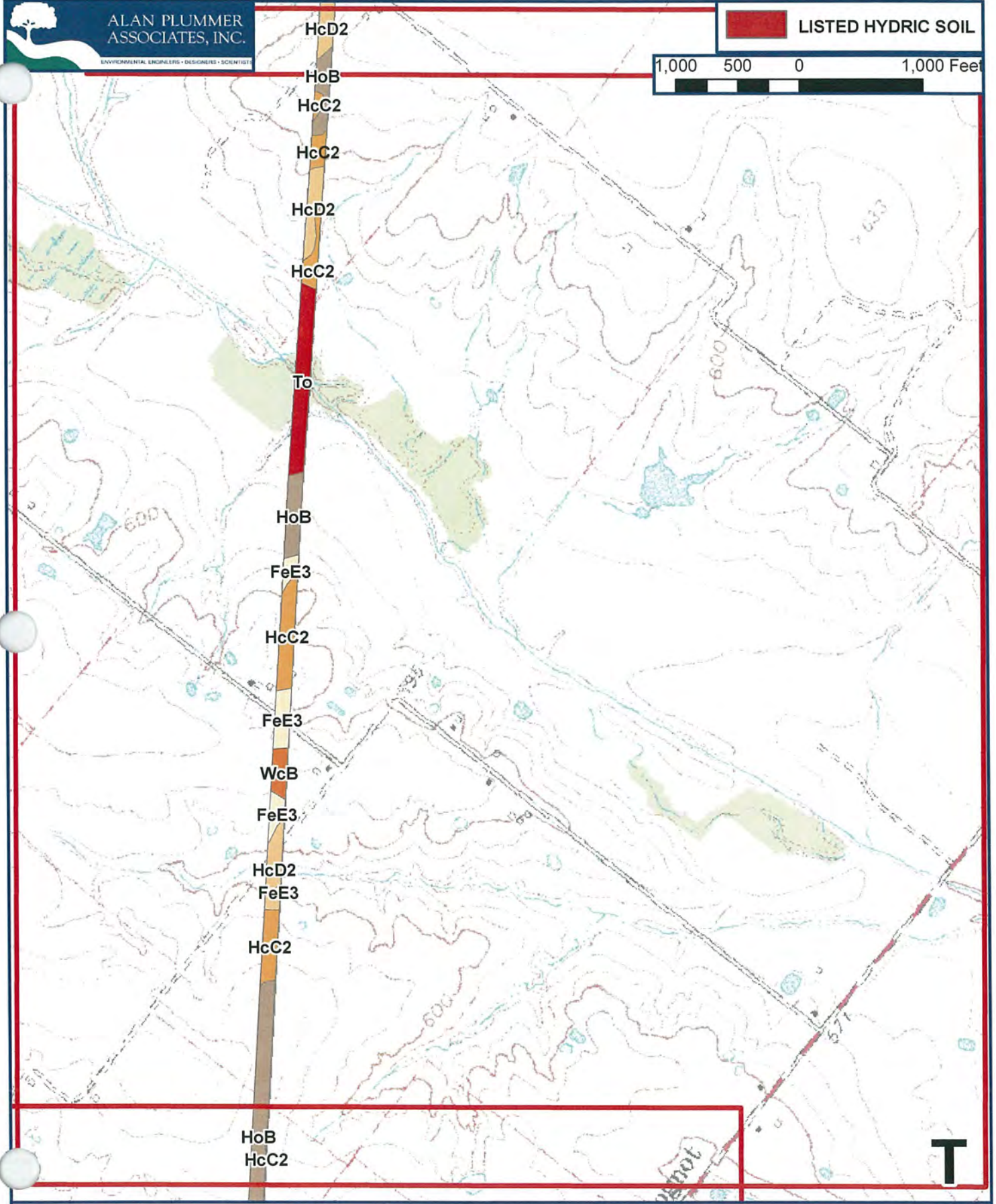

FIGURE C-20
SOIL MAP UNITS

LISTED HYDRIC SOIL



**FIGURE C-21
 SOIL MAP UNITS**

LISTED HYDRIC SOIL

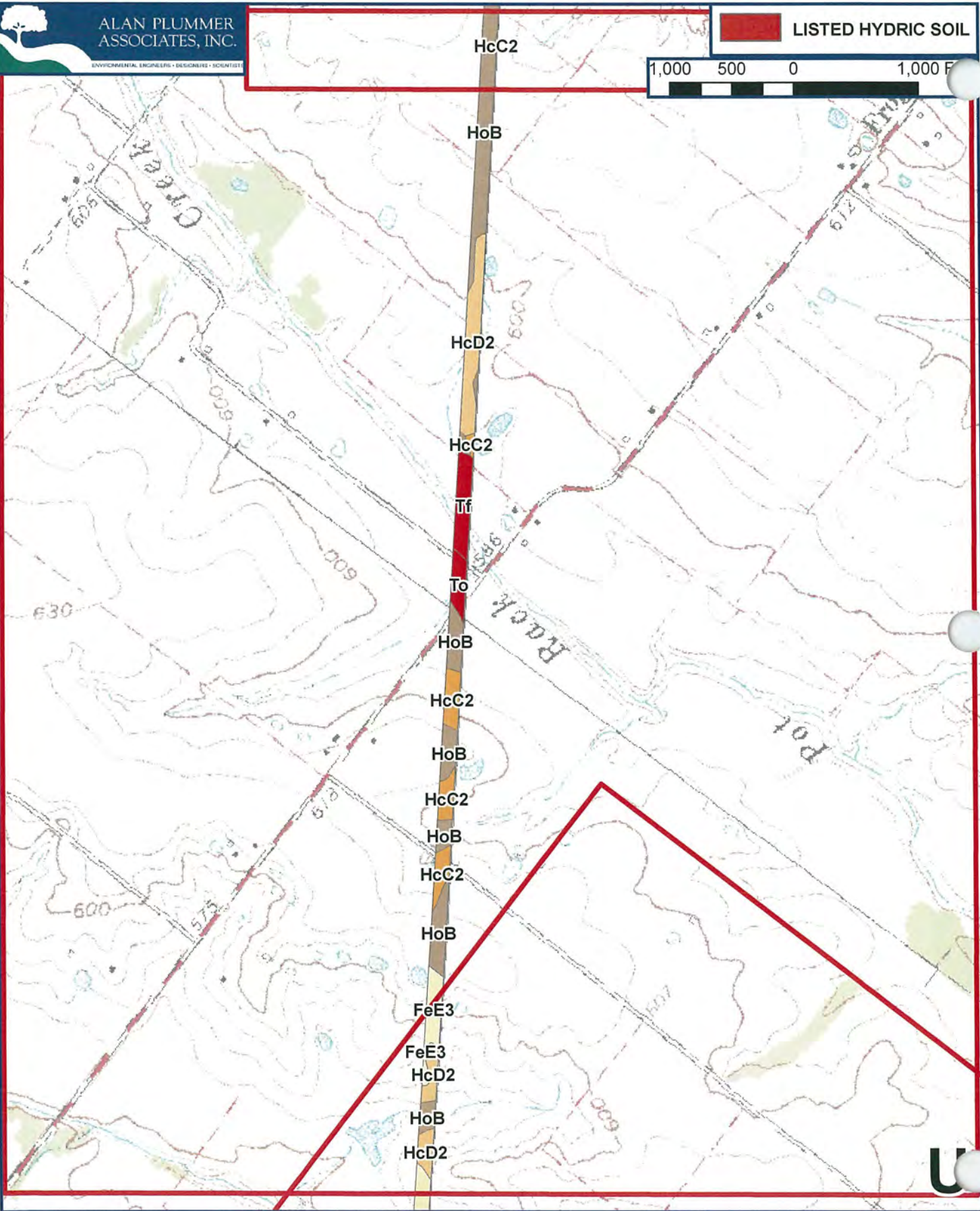
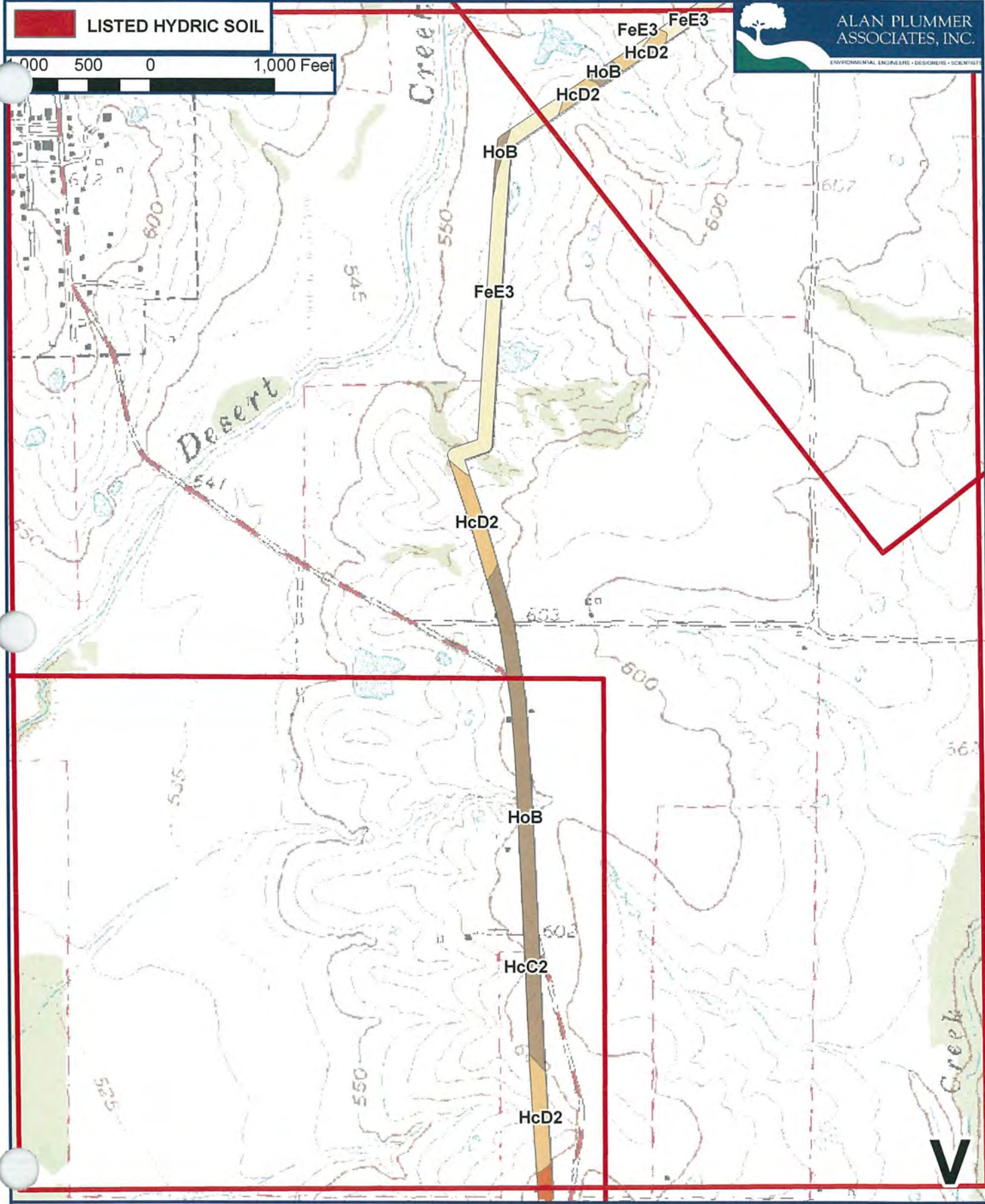

FIGURE C-22
 SOIL MAP UNITS



**FIGURE C-23
SOIL MAP UNITS**

FIGURE 23 OF 24
MARCH 24, 2008

PROPOSED BOIS D'ARC RESERVOIR - RAW WATER TRANSMISSION PIPELINE

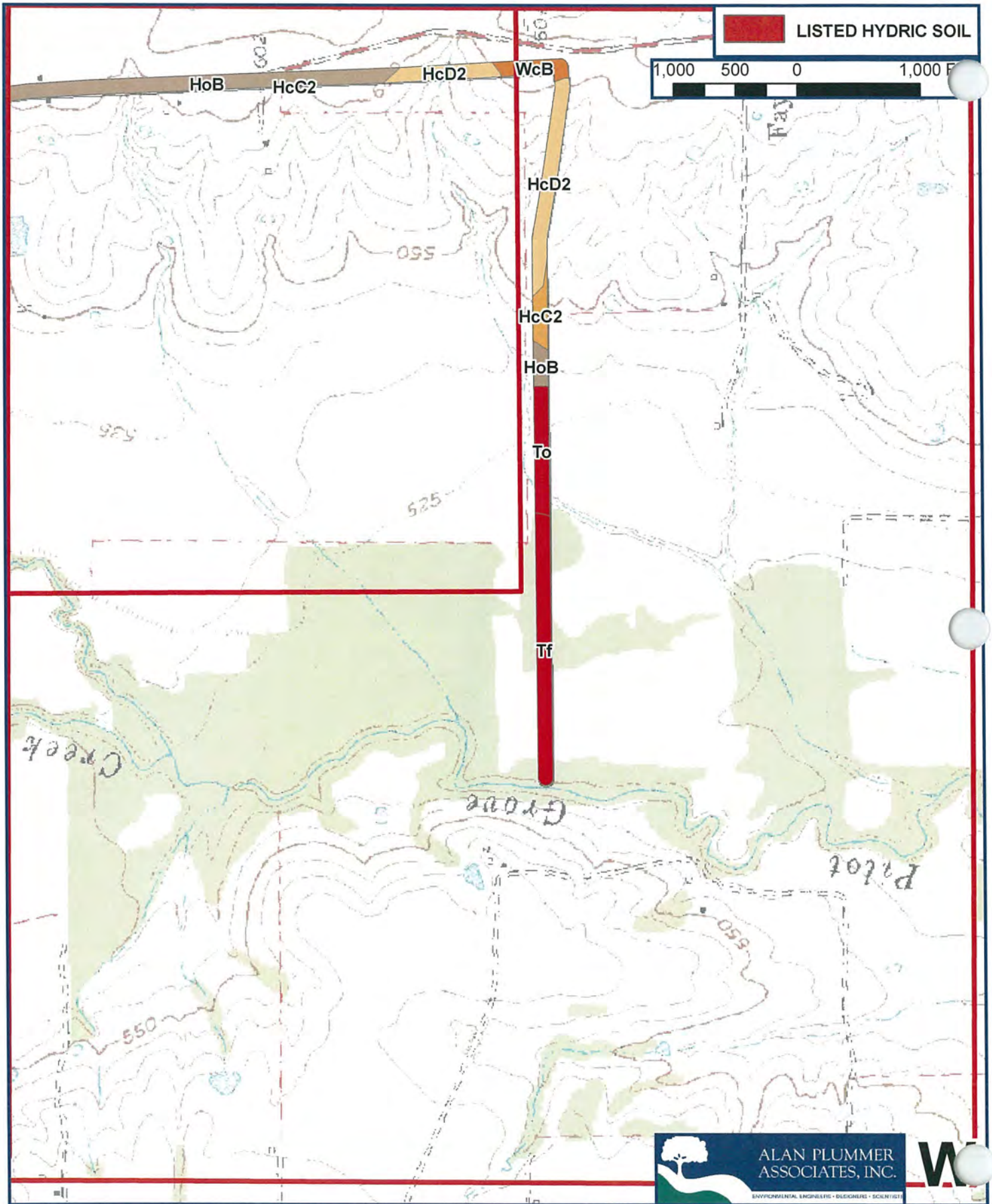

**FIGURE C-24
SOIL MAP UNITS**

FIGURE 24 OF 24
MARCH 24, 2008

PROPOSED BOIS D'ARC RESERVOIR - RAW WATER TRANSMISSION PIPELINE

DESCRIPTIONS OF THE MAPPED SOIL UNITS

From Soil Surveys of Collin, Hunt, and Fannin Counties, Texas. United States Department of Agriculture, Soil Conservation Service in Cooperation with the Texas Agriculture Experiment Station.

AUSTIN SERIES

The Austin series consists of moderately deep, well drained, moderately slowly permeable soils that formed in chalk and interbedded marl. These soils are on nearly level to sloping erosional uplands. Slopes range from 0 to 8 percent.

TAXONOMIC CLASS: Fine-silty, carbonatic, thermic Udorthentic Haplustolls

TYPICAL PEDON: Austin silty clay--cropland. (Colors are for dry soil unless otherwise stated.)

Ap--0 to 6 inches; dark grayish brown (10YR 4/2) silty clay, very dark grayish brown (10YR 3/2) moist; weak fine granular and subangular blocky structure; hard, firm but crumbly, sticky, plastic; many fine roots; many fine and very fine pores; many wormcasts; few fine calcium carbonate concretions; calcareous, moderately alkaline; clear smooth boundary. (4 to 8 inches thick)

A--6 to 15 inches; dark brown (10YR 4/3) silty clay, dark brown (10YR 3/3) moist; moderate very fine subangular blocky and granular structure; hard, firm but crumbly, sticky, plastic; many fine roots; many fine and very fine pores; many wormcasts; common fine calcium carbonate concretions; calcareous, moderately alkaline; gradual smooth boundary. (4 to 12 inches thick)

Bw1--15 to 27 inches; brown (10YR 5/3) silty clay, dark brown (10YR 4/3) moist; moderate fine subangular blocky structure; hard, firm, crumbly, sticky, plastic; few fine roots; many fine pores; many light yellowish brown (2.5Y 6/4) wormcasts; common fine calcium carbonate concretions; few fine fragments of chalk; calcareous, moderately alkaline; clear smooth boundary. (10 to 20 inches thick)

Bw2--27 to 30 inches; brown (10YR 5/3) silty clay, dark brown (10YR 4/3) moist; moderate fine subangular blocky structure; hard, firm, sticky, plastic; few fine roots; common wormcasts; about 30 percent platy fragments of chalk less than 3 inches in the axis; calcareous, moderately alkaline; clear irregular boundary. (0 to 10 inches thick)

Cr--30 to 36 inches; white (10YR 8/2) and very pale brown (10YR 8/4) platy chalk that is less hard than 3, Mohs scale; few thin tongues of brown silty clay in crevices between chalk plates.

TYPE LOCATION: McLennan County, Texas; 0.4 mile northeast of the intersection of Robinson Road and Interstate 35, which is 2 miles northeast of Lorena, 150 feet southeast of Robinson Road and 200 feet south of a metal barn.

RANGE IN CHARACTERISTICS: The solum ranges from 20 to 40 inches thick. It is silty clay loam, silty clay, or clay, with clay contents of 35 to 55 percent. Silicate clay content ranges from 20 to 35 percent. Below the A horizon, the soil ranges from 40 to 70 percent calcium carbonate equivalent. Some pedons have few to common fragments of chalk on the surface and within the sola.

The A horizon is brown, dark grayish brown, grayish brown or very dark grayish brown with hue of 7.5YR, 10YR, or 2.5Y, moist value of 3.5 or less and chroma of 2 or 3. It is 8 to 20 inches thick.

The B horizon has colors in shades of brown or gray with hue of 7.5YR, 10YR or 2.5Y, value of 5 to 7, chroma of 2 to 4.

The substrata are platy chalk, interbedded chalk and marl, or soft limestone bedrock.

COMPETING SERIES: These are the Lott series in the same family and the Altoga, Bolar, Brackett, Denton, Krum, Lewisville, Nuvalde, Patrick, Somervell, Stephen, and Valera series. Altoga and Brackett soils lack mollic epipedons, and Brackett soils have sola less than 20 inches thick. Bolar soils have more than 15 percent coarser than very fine sand in the control section. Denton and Krum soils have cracks 0.4-inch wide at depths of 20 inches when dry. Lewisville soils have less than 40 percent calcium carbonate within depths of 40 inches and are not underlain by chalk. Lott soils have sola more than 40 inches deep and are underlain by marl. Nuvalde soils have more than 35 percent noncarbonate clay in the control section. Patrick soils are sandy in the lower part of the control section. Somervell soils contain more than 35 percent coarse fragments. Stephen soils lack B horizons and are less than 20 inches thick. Valera soils have petrocalcic horizons.

GEOGRAPHIC SETTING: Austin soils are on uplands. Slope gradients are mainly less than 5 percent but range from 0 to 8 percent. The soil formed in mainly chalk or interbedded marl and chalk and is mostly of the Austin Formation. In places, the soil formed in soft limestone. The climate is warm subhumid. Mean annual precipitation ranges from 30 to 45 inches, mean annual temperature from 63 degrees to 70 degrees F, and Thornthwaite P-E indices from 44 to 66.

GEOGRAPHICALLY ASSOCIATED SOILS: These are the competing Stephen series and the Eddy, Dalco, Fairlie, Houston Black, Howe, and Whitewright series. Eddy and Whitewright soils have sola less than 20 inches deep and in addition they have ochric epipedons. Dalco, Fairlie and Houston Black soils have intersecting slickensides. Howe soils have ochric epipedons. Eddy and Stephen soils occupy similar positions to Austin soils. Dalco, Fairlie and Houston Black soils occupy lower positions in the landscape. Howe and Whitewright soils occupy adjacent sideslopes.

DRAINAGE AND PERMEABILITY: Well drained; medium to rapid runoff; moderately slow permeability.

USE AND VEGETATION: Mainly cultivated. Principal crops are small grains, cotton, and grain sorghums. Some areas are used for native range. Original vegetation was mid and tall grasses such as little bluestem, indiagrass, and sideoats grama. Grasses now are mainly grammas and buffalograss.

DISTRIBUTION AND EXTENT: The Blackland Prairies of Texas. The series is extensive.

MLRA OFFICE RESPONSIBLE: Temple, Texas

SERIES ESTABLISHED: Travis County, Texas; 1904.

REMARKS: Classification was changed 11/89 from fine-silty, carbonatic, thermic Entic Haplustolls to fine-silty, carbonatic, thermic Udorthentic Haplustolls.

Diagnostic horizons and features recognized in this pedon are:

Mollic epipedon - 0 to 15 inches, the Ap and A horizons.

Cambic horizon - 15 to 30 inches, the Bw1 and Bw2 horizons.

Paralithic contact of platy chalk at a depth of 30 inches.

Calcium carbonate equivalent in the control section of more than 40 percent.

National Cooperative Soil Survey, U.S.A.

CROCKETT SERIES

The Crockett series consists of soils that are deep to weathered shale. They are moderately well drained, and very slowly permeable. These soils are on uplands. These nearly level to moderately sloping soils formed in alkaline residuum derived from shales and clays. Slopes are dominantly 1 to 5 percent, but range from 0 to 10 percent.

TAXONOMIC CLASS: Fine, smectitic, thermic Udertic Paleustalfs

TYPICAL PEDON: Crockett fine sandy loam--cropland. (Colors are for dry soil unless otherwise stated).

Ap--0 to 8 inches; dark brown (10YR 4/3) fine sandy loam, dark brown (10YR 3/3) moist; massive; very hard, friable; few wormcasts; moderately acid; abrupt wavy boundary. (4 to 15 inches thick)

Bt1--8 to 16 inches; distinctly and coarsely mottled reddish brown (5YR 4/4) and dark brown (10YR 4/3) clay, moderate fine and medium angular blocky structure; extremely hard, very firm; few fine pores; distinct clay films and dark grayish brown stains on surfaces of peds, few fine pressure faces; vertical cracks partially filled with darker soil; few fine black iron-manganese concretions; few fine and medium prominent dark red (10R 3/6) masses of iron accumulation; moderately acid; diffuse wavy boundary.

Bt2--16 to 30 inches; olive (5Y 5/4) clay, moderate medium and coarse angular blocky structure; extremely hard, very firm; few fine pores; thin clay films on surfaces of peds, few fine pressure faces; few small slickensides; few vertical streaks of dark brown soil that is less clayey; few fine black iron-manganese concretions; common medium and coarse distinct reddish brown (5YR 4/4), and yellow (10YR 7/6) masses of iron accumulation, common medium and coarse distinct grayish brown (10YR 5/2) iron depletions; slightly acid; gradual wavy boundary.

Bt3--30 to 42 inches; pale olive (5Y 6/4) clay, olive (5Y 5/4) moist; weak coarse angular blocky structure; extremely hard, very firm; thin patchy clay films; few fine pressure faces; few small slickensides; few fine black concretions; few black streaks or stains on faces of peds; common medium distinct pale yellow (5Y 7/4) masses of iron accumulation, and common medium distinct light brownish gray (2.5Y 6/2) iron depletions; neutral; gradual wavy boundary. (combined thickness of Bt horizons is 14 to 45 inches)

BCtk--42 to 57 inches; distinctly and coarsely mottled light brownish gray (2.5Y 6/2) and pale olive (5Y 6/4) clay; weak coarse angular blocky structure; extremely hard, very firm; few thin clay films on surfaces of peds; few pressure faces and cleavage planes; few calcium carbonate concretions; few masses of calcium carbonate to 1/2-inch in diameter; few fine black iron-manganese concretions; few black streaks along pressure faces and cleavage planes; slightly alkaline; abrupt smooth boundary. (10 to 30 inches thick)

Ck1--57 to 73 inches; pale yellow (2.5Y 7/4) stratified clay loam, light yellowish brown (2.5Y 6/4) moist; massive; extremely hard and very firm in place, friable when broken; 25 percent of weakly cemented, brittle weathered shale fragments; 20 percent white calcium carbonate masses and concretions; common medium distinct dark yellowish brown (10YR 4/4) masses of iron accumulations, mainly along fractures of weathered shale; violently effervescent; moderately alkaline; diffuse smooth boundary. (0 to 30 inches thick)

Ck2--73 to 80 inches; pale yellow (2.5Y 7/4) clay loam containing about 40 percent interbedded weakly consolidated shale in layers of 1/2 to about 2 inches, shale is light olive brown (2.5Y 5/4) in lower part; massive; extremely hard, very firm in place, friable when broken; 10 percent masses of calcium carbonate in the upper part grading to none in the lower part; soil matrix is violently effervescent in spots and shale is noncalcareous; moderately alkaline.

TYPE LOCATION: Kaufman County, Texas; 250 feet east of Farm Road 986; 1.5 miles north of post office in Terrell.

RANGE IN CHARACTERISTICS: Solum thickness ranges from 40 to 60 inches. Depth to secondary carbonates ranges from 30 to 60 inches. Some pedons do not have visible carbonates. When dry, cracks 1/2 to about 2 inches wide extend from the top of the Bt horizon to depths of 2 to 5 feet. If the A horizon is eroded or thin, the soil cracks to the surface. Pressure faces and slickensides range from few to common throughout the Bt horizon and in the BC and C horizon of some pedons. The average clay content of the control section ranges from 40 to 50 percent, and COLE ranges from 0.07 to 0.10.

The thickness of the A horizon averages less than 10 inches in 50 percent or more of the pedon but ranges up to 15 inches in subsoil troughs. It has colors with hue of 7.5YR or 10YR, value of 3 to 6, and chroma of 2 to 4. Texture is fine sandy loam, very fine sandy loam, loam, silt loam or their gravelly counterparts. Siliceous pebbles range from 0 to 35 percent by volume. Reaction ranges from moderately acid to slightly alkaline. The boundary between the A and Bt horizon is commonly wavy. It is abrupt over subsoil crests and clear in subsoil troughs with an abrupt textural between the A and Bt horizons.

The Bt horizon has a base saturation of 75 to 100 percent by sum of the cations. The dominant color, degree, and distinctness of redoximorphic features in the Bt1 horizon may be extremely variable within a distance of a few feet. It ranges from prominently mottled in shades of brown, yellow, red and olive, to a matrix of reddish brown, dark yellowish brown, or brown, with few to common redoximorphic features as described in the mottled matrix. Texture of the Bt horizon is clay loam, clay, or sandy clay. Siliceous pebbles range from 0 to 15 percent by volume. Reaction of the Bt1 horizon ranges from moderately acid to neutral.

The Bt2 and lower Bt horizons have colors in shades of brown, olive, and yellow with or without reddish redoximorphic features. The reddish features decrease with depth and range from none to a few below the Bt2 horizon. Gray iron depletions range from none to common below the Bt2 horizon. Reaction ranges from slightly acid to moderately alkaline and is typically noncalcareous.

The BCtk horizon has matrix colors in shades of brown, olive, gray, yellow or the matrix is mottled with these colors or there are redoximorphic features, strata or fragments with these colors. Texture of the BCk is clay loam, or clay with or without weathered shale fragments, pockets of loamy materials, or strata of these materials interbedded.

The Ck is in shades of brown, olive or gray. It is mainly shale or clayey siltstone stratified with soil material ranging from loam to clay. Silt and clay dominate the shale materials. Siliceous pebbles range from none to about 5 percent by volume. Reaction ranges from slightly acid to moderately alkaline but typically is slightly or moderately alkaline. Masses and concretions of calcium carbonate range from none to many.

COMPETING SERIES: These are the Axtell, Bremond, Crosstell, Kurten, Navo, Tabor, and Zulch series. Similar soils are the Normangee and Ponder series. Axtell, Kurten and Tabor soils

are strongly acid in the Bt1 horizon and have base saturation of less than 75 percent. Bremond soils have sola more than 60 inches thick. Crosstell and Kurten soils have hue of 7.5YR or redder in the upper part of the Bt horizon. Navo soils do not have an abrupt textural change between the A and B horizons. In addition, Axtell, Navo, and Tabor soils also have sola from 60 to greater than 80 inches. Zulch soils have sola 20 to 40 inches thick. Normangee soils do not have an abrupt textural change between the A and Bt horizons. Ponder soils do not have redoximorphic features in the upper part of the Bt horizon.

GEOGRAPHIC SETTING: Crockett soils are on broad nearly level to moderately sloping uplands. Slopes range from 0 to 10 percent, but are mostly between 1 and 5 percent. The soil formed in residuum derived from weathered alkaline marine clays, sandy clays, or shale, interbedded with sandier materials, mainly of Cretaceous age. Mean annual temperatures range from 64 to 70 degrees F., and mean annual precipitation ranges from 32 to 45 inches. Frost free days range from 230 to 275 days, and elevation ranges from 200 to 800 feet. Thornthwaite P- E indices range from 50 to 75.

GEOGRAPHICALLY ASSOCIATED SOILS: These include the Axtell, Bonham, Burleson, Mabank, Normangee, Payne and Wilson series. Bonham soils have mollic epipedons and have sola greater than 60 inches. Burleson soils are clays throughout with slickensides. Mabank and Wilson soils are dominated by chromas or 2 or less. Axtell, Bonham, Normangee, and Payne soils are on similar landscapes with Crockett soils. Burleson, Mabank, and Wilson soils are on lower positions.

DRAINAGE AND PERMEABILITY: Moderately well drained. Permeability is very slow. Runoff is low on slopes less than 1 percent, medium on 1 to 3 percent slopes, high on 3 to 5 percent slopes, and very high on 5 to 10 percent slopes.

USE AND VEGETATION: Mainly used for growing cotton, grain sorghums, and small grain, but more than half the acreage is now in pastures. Native vegetation is prairie grasses such as bluestems, indiagrass, switchgrass, and grammas, with scattered elm, hackberry, and mesquite trees.

DISTRIBUTION AND EXTENT: Mainly in the Blackland Prairies of Texas (MLRA 86A, 86B, 87A) but minor areas are in Oklahoma. The series is extensive.

MLRA OFFICE RESPONSIBLE: Temple, Texas

SERIES ESTABLISHED: Houston County, Texas; 1905.

REMARKS: Diagnostic horizons and features recognized in this pedon are:

Ochric epipedon - 0 to 8 inches, layer is hard and massive when dry. (Ap horizon).

Pale feature - Abrupt textural change at 8 inches.

Argillic horizon - 8 to 57 inches. (Bt1, Bt2, Bt3 and BCtk horizons)

Vertic properties - COLE is 0.07 to 0.10

Crockett and Axtell soils are close competitors. Native vegetation of Crockett was dominantly prairie grasses whereas that of Axtell was trees with an understory of grasses. Morphologically, Crockett soils are less acid and leached in the upper part of the Bt horizon than Axtell soils. At present, this difference is attributed primarily to vegetation.

ADDITIONAL DATA: LSL17760-17767, Kaufman County, Texas.

Soil Interpretation Record: TX0318

National Cooperative Soil Survey, U.S.A.

DALCO SERIES

The Dalco series consists of moderately deep, moderately well drained, very slowly permeable soils. These soils are on nearly level to gently sloping uplands. Slopes range from 0 to 5 percent.

TAXONOMIC CLASS: Fine, smectitic, thermic Leptic Udic Haplusterts

TYPICAL PEDON: Dalco clay--cropland - described at center of microdepression. (Colors are for dry soil unless otherwise stated.)

Ap--0 to 9 inches; very dark gray (10YR 3/1) clay, black (10YR 2/1) moist; weak very fine angular and subangular blocky structure; very hard, very firm, very sticky and plastic; few fine roots; few fine chalk fragments and siliceous pebbles; slight effervescence; slightly alkaline; gradual smooth boundary. (4 to 10 inches thick)

Bss1--9 to 26 inches; black (10YR 2/1) clay, black (10YR 2/1) moist; moderate; very fine angular blocky structure; extremely hard, very firm, very sticky and plastic; few fine roots; common pressure faces; few grooved slickensides; slight effervescence; slightly alkaline; gradual wavy boundary.

Bss2--26 to 35 inches; dark gray (10YR 4/1) clay, very dark gray (10YR 3/1) moist; fine and very fine angular blocky structure; extremely hard, very firm, very sticky and plastic; few fine roots; common pressure faces; common grooved slickensides; few fine fragments of chalk in lower part; strong effervescence; moderately alkaline, abrupt wavy boundary. (combined Bss subhorizons are 18 to 34 inches thick)

Cr--35 to 60 inches; white (10YR 8/2) chalk that is platy in the upper 6 inches and massive below; few crevices between plates of chalk filled with marly soil material; hardness of chalk is less than 3 on Mohs scale.

TYPE LOCATION: Dallas County, Texas; 3.2 miles north of Garland. About 100 feet west of Galaxy Road and 1000 feet south of the intersection of Galaxy and Arapaho Roads.

RANGE IN CHARACTERISTICS: The solum and depth to a paralithic contact with chalk is 24 to 40 inches. It is silty clay or clay throughout. The weighted average clay content of the particle-size control section ranges from 40 to 50 percent. In undisturbed areas, gilgai microrelief consists of knolls 4 to 8 inches higher than depressions; distance between center of knoll and center of depression is 5 to 12 feet. When dry, cracks 1/2 to 2 inches wide extend from the surface to depths of 12 inches or more. Cracks remain open for 90 to 150 cumulative days during most years. Slickensides and/or wedge shaped peds begin at a depth of 8 to 18 inches. The effervescence ranges from very slight to strong. The reaction is slightly alkaline or moderately alkaline throughout.

The A horizon is black or very dark gray in hue of 10YR to 5Y, value of 2 or 3, and chroma of 1.

The Bss horizon has colors in hue of 10YR to 5Y, value of 2 to 5, and chroma of 1 or 2. Most pedons contain a few iron-manganese concretions. Calcium carbonate films, masses, and concretions and/or fragments of chalk range from few to common in most pedons.

The Cr layer is massive chalk bedrock or stratified chalk and marl. The bedrock is platy in the upper part of some pedons and commonly becomes massive within a depth of 6 to 18 inches. It is white, light gray, or very pale brown with or without streaks or coatings in shades of yellow or brown. The hardness is less than 3 on Mohs scale.

COMPETING SERIES: These include the Crawford, Greenvine, San Saba, and the similar Anhalt, Austin, Fairlie, and Vertel series. Crawford and Anhalt soils have subsoils with hue redder than 10YR. Greenvine soils have a paralithic contact with tuffaceous siltstone or shale. San Saba soils have a lithic contact of limestone. Anhalt and Vertel soils have a very-fine particle-size control section and are noneffervescent in the upper part. Austin soils have carbonatic mineralogy and do not have large slickensides. Fairlie soils are 40 to 60 inches deep to a paralithic contact of chalk.

GEOGRAPHIC SETTING: Dalco soils are on nearly level to gently sloping uplands underlain by chalk. These soils formed mainly in the Austin Chalk of Upper Cretaceous Age. Slope gradients are generally less than 3 percent but range from 0 to 5 percent. The climate is warm subhumid. Average annual precipitation ranges from 30 to 42 inches, mean annual temperature from 64 to 68 degrees F. Frost free days range from 230 to 260. Elevation ranges from 550 to 850 above sea level. Thornthwaite P-E indices from from 54 to 70.

GEOGRAPHICALLY ASSOCIATED SOILS: These are the competing Austin and Fairlie series and the Eddy, Heiden, Houston Black, and Stephen series. The Austin soils are on slightly higher positions. Fairlie soils are on similar positions. Eddy and Stephen soils are shallow to chalk and are on similar to slightly lower positions. Heiden and Houston Black soils are very deep and are on similar positions of adjacent areas with different parent material.

DRAINAGE AND PERMEABILITY: Moderately well drained with very slow permeability. Water enters the soil rapidly when it is dry and very slow when it is moist. Runoff is low on 0 to 1 percent slopes; medium on 1 to 3 percent slopes; and high on 3 to 5 percent slopes.

USE AND VEGETATION: Mostly cultivated, some areas are used for pastures with bermudagrass or kleingrass. The main crops are cotton, grain sorghum, corn, and small grain. Native vegetation consists of tall and mid grass prairies of little bluestem, big bluestem, indiangrass, switchgrass, sideoats grama and annual grasses.

DISTRIBUTION AND EXTENT: The Blackland Prairies of Texas (MLRA 86A). The series is moderately extensive.

MLRA OFFICE RESPONSIBLE: Temple, Texas

SERIES ESTABLISHED: Dallas County, Texas; 1974.

REMARKS: The Dalco series were previously included with the Austin, Houston Black, or San Saba series. Classification changed from Udic Pellusterts to Leptic Udic Haplusterts (2/94) based on issue 16, a revision to Soil Taxonomy.

Diagnostic horizons and features recognized in this pedon are:

Mollic epipedon--0 to 35 inches, the A, and Bss horizons.

Vertisol features--Cracks when dry, slickensides in Bss subhorizons.

Paralithic contact of chalk at a depth of 35 inches.

SOIL INTERPRETATION RECORD NUMBER: TX0158

National Cooperative Soil Survey, U.S.A.

ELLIS SERIES

The Ellis series consists of soils that are moderately deep, to weathered shale. They are well drained, very slowly permeable soils that formed in weakly consolidated shale. These gently sloping to moderately steep soils are on erosional uplands. Slopes range from 1 to 20 percent.

TAXONOMIC CLASS: Fine, smectitic, thermic Udic Haplusterts

TYPICAL PEDON: Ellis clay--native pasture. (Colors are for dry soil unless otherwise noted.)

A--0 to 4 inches; grayish brown (2.5Y 5/2) clay, dark grayish brown (2.5Y 4/2) moist; hard surface crust about 1/8-inch thick; moderate medium subangular and angular blocky structure; extremely hard, very firm, sticky, plastic; common fine roots; neutral; gradual smooth boundary. (2 to 10 inches thick)

Bw--4 to 13 inches; olive (5Y5/3) clay, olive (5Y 4/3) moist; moderate medium subangular and angular blocky structure; extremely hard, very firm, sticky, plastic; common fine roots; few fine and medium calcium carbonate concretions; neutral; gradual smooth boundary. (0 to 10 inches thick)

Bss1--13 to 23 inches; distinctly and coarsely mottled olive yellow (2.5Y 6/6) and gray (10YR 6/1) clay; weak coarse subangular blocky structure parting to moderate fine angular blocky structure; few small slickensides; extremely hard, very firm, sticky, plastic; few fine roots; few calcium carbonate concretions; slightly alkaline; gradual smooth boundary. (6 to 20 inches thick)

Bss2--23 to 30 inches; gray (N 6/) clay, few medium distinct mottles of brownish yellow (10YR 6/6) weak medium and fine subangular and angular blocky structure; few small slickensides; extremely hard, very firm, sticky, plastic; few fine roots; few fine calcium carbonate concretions; slightly alkaline; gradual smooth boundary. (0 to 12 inches thick)

C1--30 to 36 inches; distinctly and coarsely mottled light olive gray (5Y 6/2) and yellow (10YR 7/8) weakly consolidated shale that has clay texture; massive but natural cleavage of soft shale fragments form coarse angular rock-like structure; extremely hard, very firm, sticky, plastic; slightly alkaline; clear irregular boundary. (2 to 20 inches thick)

C2--36 to 66 inches; gray (N 6/) weakly consolidated shale that has clay texture; distinct yellow (10YR 7/8) mottles; few roots; material has rock-like angular structure; slightly alkaline.

TYPE LOCATION: Navarro County, Texas; from Kerens, 4.0 miles northwest on FM-636 to Bazette; then from the south side of Bazette, 2.2 miles east-northeast on a straight county road; then 50 feet south into pasture. Latitude 32 degrees 11' 44 N, Longitude 96 degrees 14' 22" W.

RANGE IN CHARACTERISTICS: Depth of solum is 20 to 40 inches. It is clay throughout with clay content ranging from 40 to 60 percent. Siliceous and ironstone pebbles range from none to a few throughout. Indurated iron spheroidal concretions 4 to 24 inches in diameter range from none to 1 to 3 concretions each 400 to 600 feet horizontal distance. Pressure faces and small slickensides range from few to common below the A horizon. When dry, the surface forms a crust up to 1/2-inch thick. Cracks extend from the surface to a depth of more than 12 inches. Cracks remain open 120 to 150 cumulative days in most years.

The A horizon has hue of 10YR or 2.5Y, value of 3 to 6, and chroma of 2 to 4. Horizons with moist value of 3 are less than 7 inches thick. The reaction ranges from slightly acid to moderately alkaline and most pedons are noncalcareous.

The Bw and Bss1 horizons has hue of 10YR or 2.5Y, value of 4 to 7, and chroma of 1 to 4. Gray colors are inherited from the shale. Redox concentrations in shades of brown, yellow and olive

range from none to common or the matrix is mottled with these colors. The reaction ranges from slightly acid to moderately alkaline. It is calcareous in the lower part of some pedons. Calcium carbonate concretions and masses range from none to a few.

The BSS2 horizon is in shades of gray, olive yellow, or brown typically with few to common mottles of these colors. Some pedons have a mottled matrix. The reaction ranges from neutral to moderately alkaline and calcareous in some pedons. Calcium carbonate concretions and masses range from none to common.

The C horizon is mottled or interbedded with colors in shades of gray, brown, yellow, or olive. It is clay intermixed and interbedded with soft shale. Reaction ranges from neutral to moderately alkaline with or without calcium carbonate concretions and soft masses. Some pedons have a few gypsum crystals between the interbedded layers.

COMPETING SERIES: These are Bleiblerville, Branyon, Burleson, Clarita, Dimebox, Fairlie, Heiden, Houston Black, Leson, Luling, Ovan, Sanger, Slidell, Tamford and Watonga . Bleiblerville, Branyon, Burleson, Dimebox, Fairlies, Houston Black, Leson and Slidell soils have moist chroma of 1 throughout. Clarita and Tamford soils have hue of 7.5YR or redder in the subsoil. Fairlie soils are underlain by chalk below 40 inches. Heiden, Luling, Sanger, and Slidell soils have sola over 40 inches thick. Watonga soils have mean temperature cooler than 64 degrees. Ovan soils have sola over 80 inches thick.

GEOGRAPHIC SETTING: Ellis soils are on erosional uplands on dominantly convex slopes or plane surfaces. They are on sideslopes and low escarpments above drainageways. Slopes are mostly between 5 and 12 percent but range from 1 to 20 percent. These soils formed in weakly consolidated shales of Cretaceous Age. The climate is moist subhumid. Mean annual precipitation ranges from 30 to 43 inches and the mean annual temperature ranges from 64 to 67 degrees F. Frost free days range from 230 to 250 days and elevation ranges from 250 to 400 feet. Annual Thornthwaite P-E indices ranges from 44 to 66.

GEOGRAPHICALLY ASSOCIATED SOILS: These are the similar Altoga, Ferris, and Lamar series and the Bazette, Burleson, Crockett, and Heiden soils. Altoga soils have fine-silty, carbonatic control sections and are on similar positions. Ferris soils have sola over 40 inches, and Lamar soils have fine-silty control section and are on similar positions. Bazette and Crockett soils have clayey Bt horizons. Burleson and Heiden soils have mollic colored clayey A horizons with sola thicker than 40 inches. Bazette and Heiden soils are on similar positions. Burleson and Crockett soils are above on broad smooth areas. Burleson soils are also below in slightly depressed positions.

DRAINAGE AND PERMEABILITY: Well drained. Runoff is rapid. Permeability is very slow.

USE AND VEGETATION: Used mainly for growing pasture and hay. Some areas have been cultivated, eroded, and retired to grass. Native vegetation is a moderate stand of little bluestem, indiagrass, sideoats grama and Texas wintergrass and a few small mesquite, elm, and hackberry trees. Prickly pear cacti are common in places.

DISTRIBUTION AND EXTENT: In the Blackland Prairies of Texas(MLRA 86A) and Oklahoma. The series is of moderate extent.

MLRA OFFICE RESPONSIBLE: Temple, Texas

SERIES ESTABLISHED: Ellis County, Texas; 1910.

REMARKS: Diagnostic horizons and features recognized in this pedon are:

Ochric epipedon - the A horizon from 0 to 4 inches.

Cambic horizon - the zone from 4 to 30 inches (Bw, Bss1 and Bss2 horizons)

Vertic properties- slickensides at a depth of 13 to 30 inches. High shrink-swell potential and cracks that are 0.5 to 3 inches wide at a depth of 13 inches or more.

ADDITIONAL DATA: NSSL Data: S72TX701; S72TX1291; S72TX1759.

National Cooperative Soil Survey, U.S.A.

FAIRLIE SERIES

The Fairlie series consists of deep, moderately well drained, very slowly permeable soils. These soils are on nearly level to gently sloping uplands. The slope is typically 1 to 3 percent but ranges from 0 to 5 percent.

TAXONOMIC CLASS: Fine, smectitic, thermic Udic Haplusterts

TYPICAL PEDON: Fairlie silty clay loam, on a smooth plain 2 percent slope, in a cultivated field. (Colors are for moist soil unless otherwise stated.)

Ap--0 to 5 inches; very dark gray (10YR 3/1) silty clay loam, dark gray (10YR 4/1) dry; weak medium platy structure parting to weak fine and medium blocky structure; extremely hard, firm, sticky and plastic; few fine roots; few fine black concretions; slight effervescence in spots; mildly alkaline; abrupt smooth boundary.

A--5 to 12 inches; black (5Y 2/1) silty clay, very dark gray (5Y 3/1) dry; moderate fine and medium angular blocky structure; very hard, firm, sticky and plastic; few fine roots; few pressure faces; strong effervescence; moderately alkaline; gradual wavy boundary. (combined A subhorizons are 6 to 18 inches thick)

Bss1--12 to 24 inches; black (5Y 2/1) silty clay, very dark gray (5Y 3/1) dry; moderate medium angular blocky structure; very hard, firm, sticky and plastic; few fine roots; common pressure

faces; few grooved slickensides; few fine and medium concretions of calcium carbonate; few fine iron-manganese concretions; strong effervescence; moderately alkaline; gradual wavy boundary.

Bss2--24 to 35 inches; very dark gray (5Y 3/1) silty clay, dark gray (5Y 4/1) dry; moderate fine and medium angular blocky structure; very hard, firm, sticky and plastic; few fine roots; few medium distinct olive (5Y 5/3) redox concentrations or masses with sharp boundaries; common grooved slickensides; few fine iron-manganese concretions; few medium and coarse concretions and soft masses of calcium carbonate; few fine and medium pebbles of chert; strong effervescence; moderately alkaline; gradual wavy boundary. (combined Bss subhorizons are 12 to 40 inches thick)

Bkss--35 to 54 inches; dark gray (10YR 4/1) clay, gray (10YR 5/1) dry; moderate fine and medium angular blocky structure; very hard, firm, sticky and plastic; few fine roots; common grooved slickensides; few fine and medium distinct yellowish brown (10YR 5/8) and olive (5Y 5/6) redox concentrations or masses with sharp boundaries; few vertical streaks of black (5Y 2/1) associated with cracks; few fine iron-manganese concretions; common medium and coarse concretions and soft masses of calcium carbonate; few medium pebbles of chert; strong effervescence; moderately alkaline; abrupt wavy boundary. (0 to 30 inches thick)

Cr--54 to 60 inches; white (N 8/0; 2.5Y 8/2) chalk bedrock; with streaks of olive yellow; medium platy in upper 2 inches; massive below; hardness is less than 3 on Mohs' scale.

TYPE LOCATION: Hunt County, Texas; from the intersection of Texas Highways 11 and 34 in Wolfe City, Texas; 3 miles southeast on Texas Highway 11; 1.8 miles south on county road; 0.8 mile west on county road; 0.1 mile south along turn row and 40 feet east in a cultivated field.

RANGE IN CHARACTERISTICS: The range in characteristics includes 50 percent or more of the pedon. Solum thickness and depth to a paralithic contact of chalk ranges from 40 to 60 inches. The weighted average clay content of the control section is 40 to 50 percent. When dry, cracks ranging from 0.4 to 3 inches wide extend from the surface to a depth of more than 12 inches. Cracks are open for 90 to 150 cumulative days in most years. Slickensides and/or wedge shaped peds begin at a depth of 8 to 20 inches. These are cyclic soils, and in undisturbed areas, gilgai microrelief consists of microknolls 4 to 16 inches higher than microdepressions; distance between center of knoll and center of the depression is 5 to 12 feet. Reaction is slightly or moderately alkaline, and ranges from very slight to strong effervescence. There are few to common concretions and soft masses of calcium carbonate and/or chalk fragments in most subhorizons. Iron-manganese concretions and siliceous pebbles range from none to few throughout the solum.

The A horizon has colors in hue of 10YR to 5Y, value of 2 or 3, and chroma of 1. The texture is silty clay loam, silty clay, or clay.

The Bss horizon has colors in hue of 10YR to 5Y, value of 2 to 5, and chroma of 2 or less. Texture is silty clay or clay. Redox concentrations or masses with sharp boundaries in shades of brown, yellow, or olive range from none to common.

The Bkss horizons has colors in hue of 10YR to 5Y, value of 3 to 5, and chroma of 1 or 2. Texture is silty clay or clay. Redox concentrations or masses with sharp boundaries in shades of brown, yellow, or olive range from none to common.

In some pedons, there is a discontinuous C horizon of clay, silty clay, or marly clay with thin strata of weathered chalk. Colors are mainly in shades of gray, olive, or brown. The C horizon is not diagnostic to the series and is absent in most pedons.

The Cr horizon is limestone bedrock. It is mainly chalk, or interbedded chalk and marl. It is light gray or white, and typically platy in the upper few inches, and massive below with a hardness of less than 3 on Mohs' scale.

COMPETING SERIES: These are the Bleiberville, Branyon, Burleson, Dimebox, Heiden, Houston Black, Ovan, Leson, Luling, Sanger, Slidell, and Watonga series. These soils do not have a paralithic contact with chalk within a depth of 40 to 60 inches.

GEOGRAPHIC SETTING: Fairlie soils are on nearly level to gently sloping uplands. They formed mainly in the Pecan Gap, Gober, and Austin Chalk Formations of Upper Cretaceous Age. Slopes are mainly 1 to 3 percent but range from 0 to 5 percent. Mean annual precipitation ranges from 30 to 42 inches, mean annual temperature from 64 degrees to 68 degrees F. Frost free days range from 230 to 260. Elevation ranges from 550 to 850 feet above sea level. Thornthwaite P-E indices range from 54 to 70.

GEOGRAPHICALLY ASSOCIATED SOILS: These include the competing Branyon, Burleson, Heiden, Houston Black, and Leson series. Also the Austin, Dalco, and Lott soils are associated. Austin and Lott soils are mollisols on slightly higher convex areas. Branyon and Burleson soils are on lower lying terrace positions. Dalco soils are 24 to 40 inches thick over a paralithic contact of chalk and are on similar positions. Heiden, Houston Black, and Leson soils are on similar positions of adjacent areas with different parent material.

DRAINAGE AND PERMEABILITY: Fairlie soils are moderately well drained and very slow permeability. Water enters the soil rapidly when it is dry and cracked, and very slow when the soil is saturated. Runoff is low on 0 to 1 percent slopes; moderate on 1 to 3 percent slopes; and high on 3 to 5 percent slopes.

USE AND VEGETATION: Used mainly for cultivated crops of cotton, grain sorghum, corn, and small grain, however, some areas are used for pasture and a few small areas are in rangeland. Pastures are mainly bermudagrasses; rangeland plants include eastern grama, little bluestem, indiagrass, Florida paspalum, sideoats grama, switchgrass, meadow dropseed, forbs and annual grasses.

DISTRIBUTION AND EXTENT: Blackland Prairie of Texas, MLRA 86A. The series is moderately extensive.

MLRA OFFICE RESPONSIBLE: Temple, Texas

SERIES ESTABLISHED: Grayson County, Texas; 1977.

REMARKS: Fairlie soils were previously included with the Houston Black or Austin series. Classification changed from Pellusterts to Haplusterts (2/94) based on Issue 16, a revision of Soil Taxonomy.

Diagnostic horizons and features recognized in this pedon are:

Mollic colors--0 to 35 inches, the Ap, A, Bss horizon.

Cambic horizon - 35 to 54 inches.

Vertisols features--Cracks when dry, slickensides in Bss subhorizons.

Paralithic contact of chalk at a depth of 54 inches.

SOIL INTERPRETATION RECORD NUMBER: TX0726

National Cooperative Soil Survey, U.S.A.

FERRIS SERIES

The Ferris series consists of soils that are deep to weathered shale. They are well drained, very slowly permeable soils that formed from weakly consolidated calcareous dense clays and shales. These soils are on sloping or moderately steep uplands. Slopes range from 1 to 20 percent.

TAXONOMIC CLASS: Fine, smectitic, thermic Chromic Udic Haplusterts

TYPICAL PEDON: Ferris clay--pasture. Pedon described above is an equal distance between its deep and shallow extremes. (Colors are for dry soil unless otherwise stated.)

Ap--0 to 8 inches; olive (5Y 5/3) clay, olive (5Y 4/3) moist; weak medium and fine angular blocky structure; extremely hard, very firm, very sticky and very plastic; surface has a mulch about 1/2 inch thick of fine extremely hard discrete aggregates; many fine roots; few fine calcium carbonate concretions; strongly effervescent; moderately alkaline; gradual smooth boundary. (3 to 12 inches thick)

Bw--8 to 24 inches; pale olive (5Y 6/3) clay; olive (5Y 5/3) moist; moderate fine angular blocky structure; extremely hard, very firm, very sticky and very plastic; few fine roots; common shiny pressure faces; few fine calcium carbonate concretions and masses; strongly effervescent; moderately alkaline. (6 to 20 inches thick)

Bss--24 to 40 inches; pale olive (5Y 6/3) clay; olive (5Y 5/3) moist; common fine faint brownish yellow mottles; moderate fine angular blocky structure forming wedge shaped pedis having long axes tilted up to 45 degrees from the horizontal; extremely hard, very firm, very sticky and very plastic; few fine roots; few fine pores; common coarse slickensides; pressure faces are shiny; vertical cracks 1 to 5 cm wide and 18 inches apart extend to 40 inches; few fine calcium carbonate concretions and few fine powdery masses of calcium carbonate; violently effervescent; moderately alkaline; diffuse wavy boundary. (18 to 30 inches thick)

Ck--40 to 80 inches; coarsely and prominently mottled pale olive (5Y 6/3) and yellow (2.5Y 7/8) weakly consolidated shale that has clay texture; weak coarse angular blocky structure mixed with coarse blocky rock (shale) structure; extremely hard, very firm; few fine roots between blocks of rock structure; few slickensides; common fine masses and concretions of calcium carbonate; violently effervescent; moderately alkaline.

TYPE LOCATION: Navarro County, Texas; about 15 miles west of Corsicana on Texas Highway 22; from the northeast part of Blooming Grove, 3.3 miles northward on a county road; then 190 feet east in a pasture. This location is 1.2 miles north-northwest of FP site 105B.

RANGE IN CHARACTERISTICS: The solum ranges from 40 to 60 inches thick. Texture is clay or silty clay, with clay content ranging from 40 to 60 percent. Water worn siliceous pebbles are on the surface of some pedons. When dry, cracks 1/2 to 3 inches wide extend from the surface to a depth of more than 12 inches. Cracks remain open 120 to 150 cumulative days in most years. Calcium carbonate equivalent in the control section ranges from 2 to about 30 percent.

The A horizon has hue of 10YR to 5Y, value of 3 to 6, and chroma of 2 to 4. The lower values and chromas occur where A horizons are thickest in the pedon. In pedons where the moist color value of the A horizon is less than 3.5, the horizon is less than 12 inches thick.

The Bw and Bss horizons have hue of 10YR to 5Y, value of 4 to 7, and chroma of 2 to 6. Some pedons do not have mottles in the upper part of the Bw. Gray mottles are inherited from the shale (lithochromic). Calcium carbonate concretions range from few to many in the Bw and Bss horizons, with total carbonates ranging from 2 to 30 percent.

The C horizon has hue of 10YR to 5Y, value of 5 to 7, and chroma of 1 to 8. Most pedons are coarsely and prominently mottled. It is strongly weathered calcareous clay, weakly consolidated shale that has clay texture or shales. Gypsum crystals occur in the Ck horizon of some pedons.

COMPETING SERIES: These are the Depalt, Deport, Frelsburg, Latium, and Medlin series. Similar soils are the Ellis and Heiden series. Depalt and Deport soils are non calcareous in the surface layer and, in addition, Depalt soils have dominant hue of 7.5YR or redder, and Deport soils have chroma of less than 2 in the surface horizon. Frelsburg soils have sola 60 to 80 inches thick, and formed in Tertiary Age materials. Latium soils are in slightly more moist climates and have cracks that remain open for longer periods (120 to 150 days). In addition, Latium soils are on Tertiary Age materials. Medlin soils have more than 30 percent calcium carbonate equivalent, and are dry for longer periods of time. Ellis soils have sola 20 to 40 inches thick. Heiden soils

have moist color value of 3.5 or less and chroma of 2.5 or less in the upper 12 inches in most pedons.

GEOGRAPHIC SETTING: Ferris soils are on uplands. The surfaces are convex to plane with slope gradients mostly between 5 and 12 percent, but ranging from 1 to 20 percent. Uncultivated areas often have narrow microridges and microvalleys that extend up and down the slope. The soil formed in weakly consolidated mostly Upper Cretaceous formations of calcareous marine sediments, high in montmorillonitic clays. Mean annual precipitation ranges from 28 to 42 inches, and mean annual temperature ranges from 64 to 70 degrees F. Frost free days range from 230 to 260 days and elevation ranges from 400 to 1,000 feet. The Thornthwaite P-E index is 44 to 66.

GEOGRAPHICALLY ASSOCIATED SOILS: These are the similar Ellis and Heiden series and the Altoga, Houston Black, Lamar and McLennan series. Altoga, Lamar and McLennan soils have fine-silty control sections and are on similar positions. Houston Black soils have moist value of less than 3.5 and chroma of less than 1.5 throughout the upper 12 inches. Altoga, Ellis, and Lamar soils are on similar positions with Ferris. Heiden and Houston Black soils are on smoother slightly higher positions.

DRAINAGE AND PERMEABILITY: Well drained. Permeability is very slow. Runoff is medium on 1 to 3 percent slopes, high on 3 to 5 percent slopes, and very high on slopes greater than 5 percent. Infiltration is rapid when the soil is dry and cracked, but very slow when the soil is wet.

USE AND VEGETATION: Used mainly for pasture and production of hay. Most areas have been cultivated, eroded and are now in grass. Vegetation is mainly bluestems, buffalograss and threawn grasses and scattered mesquite trees.

DISTRIBUTION AND EXTENT: Central and eastern Texas Blacklands (MLRA 86A). The series is of large extent, comprising more than 100,000 acres.

MLRA OFFICE RESPONSIBLE: Temple, Texas

SERIES ESTABLISHED: Travis County, Texas; 1969.

REMARKS: Diagnostic horizons and features recognized in this pedon are:

Ochric epipedon - the A horizon from 0 to 8 inches. (Ap horizon)

Cambic horizon - 8 to 40 inches. (Bw and Bss horizon)

Vertic properties - Slickensides at a depth of 24 to 40 inches. High shrink-swell potential and cracks that are 1/2 to 3 inches wide at a depth of 12 inches or more.

ADDITIONAL DATA: NSSL Data: Hopkins County, TX S68-223-001 (68L895-68L899).

Soil Interpretation Record Number: TX0296 , TX1150 (COOL)

National Cooperative Soil Survey, U.S.A.

FRIOTON SERIES

The Frioton series consists of very deep, well drained, moderately slowly permeable soils. They formed in loamy and clayey sediments of Pleistocene age. These nearly level soils are on smooth flood plains and formed under trees with an understory of native grasses. Slopes are 0 to 1 percent.

TAXONOMIC CLASS: Fine, mixed, active, thermic Cumulic Hapludolls

TYPICAL PEDON: Frioton silty clay loam--pasture. (Colors are for moist soil unless otherwise stated.)

A11--0 to 24 inches; very dark brown (10YR 2/2) silty clay loam, very dark gray (10YR 3/1) dry; strong fine granular structure; hard, friable; 10 percent by volume of fragments of limestone less than 3 inches in diameter in the lower part; calcareous, moderately alkaline; diffuse smooth boundary. (12 to 28 inches thick)

A12--24 to 37 inches; very dark gray (10YR 3/1) silty clay loam, dark gray (10YR 4/1) dry; moderate medium subangular blocky structure; hard, firm; 2 percent by volume of fragments of limestone less than 3 inches in diameter; few fine threads of carbonate; calcareous, moderately alkaline; gradual smooth boundary. (10 to 30 inches thick)

C--37 to 62 inches; very dark gray (10YR 3/1) silty clay loam, dark gray (10YR 4/1) dry; massive; hard, firm; 10 percent by volume of fragments of limestone less than 3 inches in diameter; calcareous, moderately alkaline.

TYPE LOCATION: Bryan County, Oklahoma; about 3 miles southwest of Caddo; 360 feet east and 820 feet south of the northwest corner of sec. 24, T. 5 S., R. 9 E.

RANGE IN CHARACTERISTICS: Thickness of the mollic epipedon ranges from 24 to more than 50 inches. Texture throughout the soil is silty clay loam, clay loam, silty clay, or their gravelly counterparts.

The A horizon is black (10YR 2/1), very dark brown (10YR 2/2), very dark gray (10YR 3/1), very dark grayish brown (10YR 3/2), or dark brown (10YR 3/3; 7.5YR 3/2). Reaction is slightly or moderately alkaline. Some pedons are noncalcareous in the upper 10 inches of the A11 horizon. The clay content of the control section ranges from 35 to 50 percent. The control section of some pedons contains 5 to 15 percent by volume of fragments of limestone or chert. Below a

depth of 24 inches, some pedons have B horizons that have higher value or chroma than the A horizons.

The C horizon is very dark gray (10YR 3/1), very dark grayish brown (10YR 3/2), dark brown (10YR 3/3; 7.5YR 3/2), dark gray (10YR 4/1), dark grayish brown (10YR 4/2), brown (10YR 4/3, 5/3; 7.5YR 4/2, 5/2), or gray (10YR 5/1). Some pedons have thin strata of more loamy or clayey sediments in the C horizon.

COMPETING SERIES: These are the Egan series and the closely competing Buxin, Catalpa, Moreland, Pledger, and Ringo series. Buxin, Moreland, and Pledger soils have vertic properties. Catalpa and Ringo soils have mollic epipedons less than 24 inches thick. In addition, Ringo soils are underlain by shale at depths ranging from 20 to 40 inches. Egan soils lack carbonates within the profile.

GEOGRAPHIC SETTING: These soils occur on nearly level flood plains. Slopes range from 0 to 1 percent. They formed in loamy and clayey sediments. They are flooded for very brief periods during the months of February through July. Mean annual temperature ranges from 62 degrees to 70 degrees F.; average annual precipitation ranges from 40 to 50 inches; Thornthwaite P-E indices range from 64 to 80. Frost free days range from 210 to 240. Elevation ranges from 400 to 800 feet.

GEOGRAPHICALLY ASSOCIATED SOILS: These are the Gowton, Kaufman, and Trinity series. Gowton and Kaufman soils are down stream and usually on larger streams. Trinity soils are a greater distance from the stream channel. Gowton soils are fine-loamy. Kaufman and Trinity soils have vertic properties.

DRAINAGE AND PERMEABILITY: Well drained; low runoff; moderately slow permeability.

USE AND VEGETATION: Used primarily for bermudagrass pasture but some areas are cultivated to wheat, grain sorghum, soybeans, peanuts, and alfalfa. Native vegetation is oak, elm, hackberry, pecan, and ash with an understory of native grass.

DISTRIBUTION AND EXTENT: Adjacent to the drainageways of the Blacklands in southeastern Oklahoma, possibly Texas, southwestern Arkansas, and Louisiana. These soils are moderately extensive.

MLRA OFFICE RESPONSIBLE: Temple, Texas

SERIES ESTABLISHED: Bryan County, Oklahoma; 1975.

REMARKS: This series formerly would have been classified in the Alluvial great soil group and included in the Frio series.

HEIDEN SERIES

The Heiden series consists of soils that are well drained and very slowly permeable ..They are deep to weathered shale. These soils are on nearly level to moderately steep uplands. Slopes are mainly 3 to 8 percent but range from 0.5 to 20 percent.

TAXONOMIC CLASS: Fine, smectitic, thermic Udic Haplusterts

TYPICAL PEDON: Heiden clay--cropland. Pedon described near its deepest part. (Colors are for dry soil unless otherwise stated.)

Ap--0 to 6 inches; dark grayish brown (10YR 4/2) clay, very dark grayish brown (10YR 3/2) moist; weak angular blocky structure; very hard, very firm, very sticky and very plastic; many fine roots; few wormcasts; few fragments of snail shells; strongly effervescent; moderately alkaline; abrupt boundary. (4 to 8 inches thick)

A--6 to 18 inches; dark grayish brown (10YR 4/2) clay, very dark grayish brown (10YR 3/2) moist; moderate fine angular blocky structure; few wedge shaped peds in lower part; extremely hard, very firm ,very sticky and very plastic; few fine roots; shiny faces on peds; strongly effervescent; moderately alkaline; diffuse wavy boundary. (8 to 22 inches thick)

Bssk1--18 to 36 inches; dark grayish brown (10YR 4/2) clay, very dark grayish brown (10YR 3/2) moist; moderate medium and coarse angular blocky structure, wedge shaped peds are about 1 to 3 inches long and axis tilted 10 to 60 degrees from the horizontal; extremely hard, very firm, very sticky and very plastic; many slickensides; common fine calcium carbonate concretions; strongly effervescent; moderately alkaline; diffuse wavy boundary. (0 to 20 inches thick)

Bssk2--36 to 58 inches; olive gray (5Y 5/2) clay, olive gray (5Y 4/2) moist; few fine faint olive mottles and streaks; weak coarse angular blocky structure, wedge shaped peds are about 1 to 3 inches long and axis tilted 10 to 60 degrees from the horizontal; extremely hard, very firm, very sticky and very plastic; many distinct slickensides; common fine calcium carbonate concretions; violently effervescent; moderately alkaline; diffuse wavy boundary. (12 to 40 inches thick)

C--58 to 70 inches; prominently and coarsely mottled olive (5Y 5/3) moist; and yellow (5Y 7/6) moist, clay and weakly consolidated shale; few fine olive and yellow mottles; massive, with a few slickensides in the upper part; extremely hard, very firm and very plastic; violently effervescent; moderately alkaline.

TYPE LOCATION: Bell County, Texas; From the intersection of Texas Highway 36 and Farm Road 436 in Heidenheimer; 0.57 miles southeast on Texas Highway 36; 1 5 feet southwest of fence in cropland.

RANGE IN CHARACTERISTICS: Solum thickness ranges from about 40 to 65 inches. They are thinnest in microknolls or microridges and thickest in centers of microdepressions or microvalleys. Texture throughout the soil is clay or silty clay. Weighted average clay content ranges from 40 to 60 percent. Cracks remain open 90 to 150 cumulative days in most years. Slickensides and wedge-shaped peds begin at a depth of 10 to 24 inches. Undisturbed areas have gilgai microrelief with microknolls about 4 to 10 inches above microdepressions. On slopes above 5 percent gilgai are linear with slope.

The A horizons have hue of 10YR, 2.5Y or 5Y, value of 3 to 5, and chroma of 1 to 3. Moist color values range from 2 to slightly less than 3.5. Where chromas are less than 1.5, the surface layer is less than 12 inches thick in more than one-half of the pedon. The A horizons are dominantly calcareous, but range to noncalcareous and slightly alkaline in the upper 12 inches. Smooth siliceous pebbles or limestone fragments less than 10 inches across are on and in the surface layers of some pedons.

The Bss horizons have hue of 10YR, 2.5Y or 5Y; value of 4 to 7; and chroma of 2 to 4. They are typically mottled with these colors. Calcium carbonate in the form of masses, threads and concretions range from none in the upper part to many in the lower part with total carbonates ranging from 2 to 35 percent. Gypsum crystals are in the lower part of some pedons.

The C horizon varies from clay, strongly weathered shale, to slightly weathered calcareous shales, with an intermingling of soil and rock structure.

COMPETING SERIES: These include the Bleiberville, Branyon, Burleson, Clarita, Dimebox, Fairlie, Houston Black, Leson, Luling, Ovan, Sanger, Slidell, Tamford and Watonga. Bleiberville, Branyon, Burleson, Dimebox, Fairlie, Houston Black, Leson and Slidell have moist chroma of 1 throughout. Clarita and Tamford soils have hue of 7.5YR or redder in the subsoil. Fairlie soils are underlain by chalk below 40 inches. Burleson, Dimebox, Leson and Luling are non-calcareous in the surface. Sanger and Slidell soils contain more calcium carbonate in the control section and are underlain by marl. Watonga soils have mean temperature cooler than 64 degrees. Ovan soils have sola over 80 inches thick and are in flood plains.

GEOGRAPHIC SETTING: Heiden soils are on erosional uplands. Slopes are mostly 3 to 8 percent, but range from 0 percent to 20 percent. Surfaces are dominantly convex but plane surfaces occur in some areas of low gradients. Most untilled areas have a microrelief of microvalleys 4 to 12 feet wide and 3 to about 12 inches deep, and microridges about 4 to 12 feet wide that extend up and down slope. The soils formed, mainly, in weakly consolidated Upper Cretaceous formations of calcareous marine sediments, high in montmorillonite clays. The climate is moist subhumid. The mean annual precipitation ranges from 28 to 42 inches and the mean annual temperature ranges from 64 to 70 degrees F. Frost free days range from 225 to 275 days and elevation ranges from 400 to 1000 feet. Thornthwaite annual P-E indices range from 44 to 66.

GEOGRAPHICALLY ASSOCIATED SOILS: These are the competing Branyon, Burleson, Crockett, Ellis, Fairlie, Ferris, Houston Black, Lott, McLennan, Ovan and Wilson series. Crockett and Wilson soils have argillic horizons. Ferris, Ellis and McLennan soils have color

values higher than 3.5 in the upper 12 inches. Lott and McLennan soils have fine silty control sections. Ferris, Ellis, Lott and McLennan soils are on lower more sloping positions. Branyon, Burleson, Crockett, Wilson and Ovan are on lower positions. Houston Black is on similar positions. Fairlie and Lott soils are on slightly higher positions.

DRAINAGE AND PERMEABILITY: Well drained. Permeability is very slow. Runoff is low on 0 to 1 percent slopes, medium on 1 to 3 percent slopes, high on 3 to 5 percent slopes and very high on 5 to 20 percent slopes. Infiltration is rapid when the soil is dry and cracked, but very slow when the soil is wet.

USE AND VEGETATION: Used mainly for pasture and hay. Many areas have been cultivated but are now in grass. Some areas are used for growing grain sorghum and cotton. Grasses are mainly bluestem, buffalograss, and threeawn grass. Scattered mesquite trees occur in places.

DISTRIBUTION AND EXTENT: Central and eastern Texas in the Blackland MLRA (86A). The series is extensive.

MLRA OFFICE RESPONSIBLE: Temple, Texas

SERIES ESTABLISHED: Travis County, Texas, 1969

REMARKS: These soils formerly were included with the Houston series.

Diagnostic horizons and features recognized in this pedon are:

Mollic epipedon - the A horizons from 0 to 18 inches.

Vertic Properties - slickensides at a depth of 18 to 58 inches. High shrink-swell potential and cracks that are 1/2 to 3 inches wide at a depth of 12 inches during dry periods

SIR Number.- TX0151, TX0152 (Stony), TX1149 (Cool), TX1151 (Stony, Cool).

National Cooperative Soil Survey, U.S.A.

HOUSTON SERIES

The Houston series consists of moderately well drained, slowly permeable, cyclic soils that formed in alkaline clays and chalk of the Blackland Prairies. These clayey soils have very high shrink-swell potential. Slope ranges from 0 to 8 percent.

TAXONOMIC CLASS: Very-fine, smectitic, thermic Oxyaquic Hapluderts

TYPICAL PEDON: Houston clay in the center of a micro-pasture. (Colors are for moist soil unless otherwise stated.)

A11--0 to 10 inches; very dark gray (5Y 3/1) clay; moderate fine and medium granular structure; hard, firm, very plastic; common fine roots; mildly alkaline; gradual smooth boundary. (4 to 11 inches thick)

A12--10 to 25 inches; dark olive gray (5Y 3/2) clay; moderate fine angular and subangular blocky structure; hard, firm, very plastic; common fine roots; mildly alkaline; clear irregular boundary. (0 to 24 inches thick)

AC--25 to 42 inches; olive gray (5Y 4/2) clay; few fine faint mottles of very dark gray; large wedge-shaped aggregates that are bordered by intersecting slickensides; parts to successively smaller angular blocky structure; very hard, firm, very plastic, sticky; few fine black concretions; common medium and coarse calcium carbonate concretions; moderately alkaline; gradual wavy boundary. (5 to 27 inches thick)

C1--42 to 58 inches; olive (5Y 4/3) clay; few fine faint mottles of very dark gray; large wedge-shaped aggregates that are bordered by intersecting slickensides; parts to angular blocky structure; very hard, extremely firm, very firm, very plastic, sticky; few fine black concretions; common medium and coarse calcium carbonate concretions; calcareous; moderately alkaline; gradual wavy boundary. (5 to 26 inches thick)

C2--58 to 72 inches; light olive brown (2.5Y 5/6) clay; common fine distinct olive gray and few fine faint yellowish brown mottles; large wedge-shaped aggregates that are bordered by intersecting slickensides; parts to angular blocky structure; very hard, extremely firm, plastic; few medium and coarse calcium carbonate concretions; calcareous; moderately alkaline.

TYPE LOCATION: Dallas County, Alabama; 1 mile northwest of Black Belt Substation and 100 yards west of the Vaiden plots in a pasture, 1000 feet north and 1000 feet west of the SE corner of the NW 1/4 sec. 2, T. 17 N., R. 8 E.

RANGE IN CHARACTERISTICS: Depth to bedrock ranges from 4 to 9 feet. The soil is clay throughout, ranging from 60 to 80 percent with 60 to 70 percent being most common. Common or many intersecting slickensides are in the AC and C horizons. These are cyclic soils, with cycles of microknolls and microbasins repeated at linear intervals of 6 to 12 feet. The amplitude of waviness of the boundary between the A and AC horizon ranges from about 9 to 26 inches. The A horizon ranges from slightly acid through mildly alkaline. Few, common, or many calcium carbonate concretions occur in the AC and C horizons.

The A11 horizon has hue of 10YR, 2.5Y, or 5Y, value of 2 or 3, and chroma of 1 or 2, or it is (N 2/0) or (N 3/0).

The A12 horizon has hue of 10YR, 2.5Y, or 5Y, value of 2 or 3, and chroma of 2. In some pedons it has value of 4 or 5, and chroma of 2 at depths more than 30 cm from the surface.

The AC horizon has hue of 10YR, 2.5Y, or 5Y, value of 4 or 5, and chroma of 2 or 3. It is slightly acid through moderately alkaline.

The C horizon has hue of 10YR, 2.5Y, or 5Y, value of 4 or 5, and chroma 3 through 6. Many pedons have C horizons mottled with shades of brown, yellow or gray. It ranges from neutral to moderately alkaline. Chalk bedrock is commonly light gray or pale yellow in color.

COMPETING SERIES: There are no other series in this family. Closely similar soils include the Brooksville, LaCerde, Louin, Naclina, Okolona, Redco, Terouge, and Vamont series. All of these soils except LaCerde and Redco have less than 60 percent clay in their control section. LaCerde and Redco soils have values of 4 or more within 30 cm of the surface and have mottles associated with wetness.

GEOGRAPHIC SETTING: Houston soils are on nearly level to sloping uplands with slope gradients of 0 to 8 percent. They are formed in alkaline clays and soft chalk. The climate is warm and humid. Near the type location the average annual temperature is 67 degrees F. and the average annual precipitation is about 51 inches.

GEOGRAPHICALLY ASSOCIATED SOILS: These include the Binnsville, Catalpa, Demopolis, Sumter, and Vaiden series. Binnsville and Demopolis soils have chalk within 20 inches of the surface. Catalpa soils have irregular distribution of organic matter and less than 60 percent clay in the control section. Sumter soils have more than 40 percent calcium carbonate equivalent and lack intersecting slickensides. Vaiden soils are more acid and have distinct or prominent mottles within 20 inches of the surface.

DRAINAGE AND PERMEABILITY: Moderately well drained. Runoff is medium to rapid and permeability is slow.

USE AND VEGETATION: Used mainly for pasture and hay crops. Some acreage is sed for soybeans.

DISTRIBUTION AND EXTENT: The Blackland Prairies of Alabama and Mississippi; possibly Arkansas, Louisiana, and Texas. The series is extensive.

MLRA OFFICE RESPONSIBLE: Auburn, Alabama

SERIES ESTABLISHED: Brazoria County, Texas; 1902.

REMARKS: The Houston series was formerly classified in the Grumusols great soil group.

ADDITIONAL DATA: The typical pedon is characterized in the Southern Cooperative Series N. 130, entitled @Properites of Alabama and Mississippi Black Belt Soils,@ published at Auburn University, February 1968. The pedon is Houston N. 28 - Ala., described on page 34 of that publication.

National Cooperative Soil Survey, U. S. A.

HOUSTON BLACK SERIES

The Houston Black series consists of very deep, moderately well drained, very slowly permeable soils that formed from weakly consolidated calcareous clays and marls of Cretaceous Age. These soils are on nearly level to moderately sloping uplands. Slopes are mainly 1 to 3 percent, but range from 0 to 8 percent.

TAXONOMIC CLASS: Fine, smectitic, thermic Udic Haplusterts

TYPICAL PEDON: At center of microdepression--pasture. (Colors are for dry soil unless otherwise stated.)

A1--0 to 8 inches; very dark gray (10YR 3/1) clay, black (10YR 2/1) moist; moderate fine subangular blocky and moderate medium granular structure; extremely hard, very firm, very sticky and plastic; many fine roots; common very fine pores; common medium wormcasts; few fragments of snail shells; many very fine shiny faces of peds; few fine black concretions; few fine calcium carbonate concretions; strong effervescence; moderately alkaline; clear wavy boundary. (6 to 12 inches thick)

A2--8 to 24 inches; very dark gray (10YR 3/1) clay, black (10YR 2/1) moist; moderate fine and very fine angular blocky natural fragments that form wedge like shapes peds; extremely hard, very firm, very sticky and very plastic; common fine roots; common very fine pores; shiny surfaces on many fine and very fine natural soil fragments; few fine black concretions; few fine calcium carbonate concretions; strong effervescence; moderately alkaline; gradual wavy boundary. (0 to 20 inches thick)

Bss--24 to 38 inches; dark gray (10YR 4/1) clay, very dark gray (10YR 3/1) moist; strong coarse angular blocky natural fragments that form wedge shaped peds: extremely hard, very firm, very sticky and very plastic; few fine roots; common very fine pores; many intersecting slickensides shiny surfaces on many fine, medium, and coarse ped faces; few fine black concretions; few fine calcium carbonate concretions; strong effervescence; moderately alkaline; clear wavy boundary. (0 to 20 inches thick)

Bssk1--38 to 80 inches; grayish brown (10YR 5/2) clay, dark grayish brown (10YR 4/2) moist; few medium distinct olive brown (2.5YR 4/4) and many coarse faint gray (10YR 5/1) mottles; strong coarse angular blocky natural fragments that form wedge shaped peds; extremely hard, very firm, very sticky and very plastic; few fine roots; few very fine pores; many intersecting slickensides shiny surfaces on many fine, medium, and coarse ped faces; few fine dark gray vertical streaks; few fine black concretions and soft brown masses; few fine and medium calcium carbonate concretions and soft masses; violent effervescence; moderately alkaline; gradual wavy boundary. (10 to 50 inches thick)

Bssk2--80 to 104 inches; coarsely and distinctly mottled light olive brown (2.5Y 5/4) and gray (10YR 6/1) clay; common fine faint olive brown mottles; weak medium and coarse angular blocky natural fragments that form wedge shaped pedis; very firm, very sticky and very plastic; few very fine roots and pores; many prominent slickensides; few fine soft brown masses; few medium soft masses of calcium carbonate; violent effervescence; moderately alkaline.

TYPE LOCATION: Travis County, Texas; from intersection of Farm Road 973 and U. S. Highway 290 in Manor, 3.5 miles east on U. S. Highway 290, 2.4 miles northeast on Farm Road 1100, 1.0 mile northwest and 3.0 miles northeast on Manda Road, 0.5 mile southeast on Lund Road, 900 feet southwest on field road, 105 feet east in pasture.

RANGE IN CHARACTERISTICS: Thickness of the combined A and B horizons is more than 80 inches. The weighted average clay content of the particle size control section is 40 to 60 percent. The soil is usually moist, but when dry it has cracks ranging from 0.5 to 4 inches wide extend from the surface to a depth of 12 inches or more. Cracks remain open for 90 to 150 cumulative days in most years. Slickensides begin at depths ranging from about 16 to 24 inches below the soil surface. The soil is clayey throughout with dominant textures being clay or silty clay. Some pedons have 15 to 30 percent by volume of siliceous and other pebbles in the upper 12 inches. Dominant textures are clay or silty clay in the upper 12 inches. When dry the surface has a granular mulch about 1/2 inch thick of extremely hard discrete granules. Cycles of microdepressions and microknolls are repeated each 10 to 24 feet. In virgin areas, microknolls are 3 to 18 inches higher than microdepressions. Chromas are less than 1.5 to depths of 30 to 60 inches in the center of microdepressions and 10 to 18 inches in the center of microknolls. The extremes of amplitude or waviness of the boundary between the A and B horizons vary from about 20 to 48 inches from the center of the microknoll to the center of the microdepression.

The A horizons have hue of 10YR to 5Y, value of 2 to 4, and chroma of 0 or 1. Soil reaction is moderately alkaline and calcareous, however, in the center of the microdepressions, the reaction ranges from slightly alkaline to moderately alkaline.

The Bss horizon has hue of 10YR, value of 2 to 4 and chroma of 0 to 1. Chroma ranges to 2 in some pedons. The lower B horizons have hue of 10YR, 2.5Y or 5Y, value of 4 to 7, and chroma of 2 to 6. The grayish brown and dark grayish brown colors occur in microdepressions and grayish brown to olive or yellow colors occur in microknolls. In some pedons chroma ranges to 8 in microknolls.

The lower B or Bk horizon has olive, brown and yellow mottles or is olive to yellow with gray mottles. Calcium carbonate content in the form of masses, threads and concretions range from few to many with total carbonate content ranging from 2 to 35 percent.

Water worn gravel of chert and quartzite are on the surface or within the A and B horizons of some pedons. Few weakly cemented iron manganese oxide concretions ranging from 1 to 5 mm in diameter occur throughout the soil.

COMPETING SERIES: These are the Bleiberville, Branyon, Burleson, Clarita, Dimebox, Fairlie, Heiden, Leson, Luling, Ovan, Sanger, Slidell, Tamford, and Watonga soils. Bleiberville

soils are formed on Tertiary age sediments. Branyon soils are on terraces and have less amplitude of waviness. Burleson and Leson soils on terraces and are non-calcareous in the surface layer. Clarita soils have hue of 7.5YR or redder in the subsoil.. Dimebox is non-calcareous in the surface. Fairlie soils have a paralithic contact with chalk at 40 to 60 inches. Heiden, Luling, Ovan and Sanger soils have matrix chroma of 2 or more throughout and Ovan soils are on flood plains. Slidell soils contain more calcium carbonate in the control section and are underlain by marl. Tamford soils have hue of 7.5YR or redder in the subsoil. Watonga soils have sola less than 60 inches thick and are in slightly cooler climates

GEOGRAPHIC SETTING: Houston Black soils are on nearly level to sloping uplands. Slopes range from 0 to 8 percent, but are mainly 1 to 3 percent. The soil formed in calcareous clays and marls mainly of the Taylor Marl geological formation. In places, the substrata are chalks or shales. The climate is warm and subhumid. The mean annual precipitation ranges from 28 to 42 inches and the mean annual temperature ranges from 63 to 70 degrees F. Frost free days range from 220 to 250 days and elevation ranges from 400 to 1000 feet. Thornthwaite annual P-E indices range from 44 to 66.

GEOGRAPHICALLY ASSOCIATED SOILS: These are the Burleson, Branyon, Fairlie, Heiden and Ovan in the same family, and the similar Austin and Ferris soils. Burleson, Branyon and Ovan soils are on lower positions. Heiden soils are on similar landscapes with Houston Black. Austin soils are on slightly higher positions. Austin soils are underlain by chalk 20 to 40 inches dry, and prairie soils have chalk at 40 to 60 inches in depth. Ferris soils are on slightly sloping hillsides and have moist color values more than 3.5 and chroma more than 1.5 in the upper 12 inches.

DRAINAGE AND PERMEABILITY: Moderately well drained. Slow to rapid surface runoff. Water enters the soil rapidly when it is dry and cracked, and very slowly when it is moist. Permeability is very slow.

USE AND VEGETATION: Nearly all is cultivated and used for growing cotton, sorghums, and corn. Cotton root rot is prevalent on most areas and limits cotton yields and the use of some legumes in rotations. Native vegetation consists of tall and mid grass prairies of little bluestem, big bluestem, indiagrass, switchgrass, and sideoats grama, with scattered elm, mesquite, and hackberry trees.

DISTRIBUTION AND EXTENT: The Blackland Prairies and eastern part of the Grand Prairies of Texas. The series is extensive.

MLRA OFFICE RESPONSIBLE: Temple, Texas

SERIES ESTABLISHED: Brazoria County, Texas; 1902. The word "Black" was capitalized in the correlation of Kaufman County in 1947.

REMARKS: Diagnostic horizons and features recognized in this pedon are:

Mollic epipedon - 0 to 38 inches

Vertic features - slickensides at a depth of 24 to 80 inches depth. High shrink-swell potential and cracks that are 1/2 to 4 inches wide at 12 inch depths during dry periods.

ADDITIONAL DATA: E. H. Templin, I. C. Mowery, and G. W. Kunze, Houston Black clay the Type Grumusol: Soil Science Society of American Proceedings, Vol. 20, No.1, January 1956. SSIR-30, S53TX-70-1, S54TX-14-90. National Soil Survey Laboratory, S77TS-027-001, S77TX-027-002, S78TX-027-003.

SIR Number. TX0093

National Cooperative Soil Survey, U.S.A.

HOWE SERIES

The Howe series consists of moderately deep, well drained, moderately permeable soils that formed in weakly cemented chalk interbedded with marl of Upper Cretaceous Age. These soils are on gently sloping to strongly sloping uplands. Slopes are dominantly 5 to 12 percent but range from 3 to 12 percent.

TAXONOMIC CLASS: Fine-silty, carbonatic, thermic Udic Haplustepts

TYPICAL PEDON: Howe silty clay loam--pasture. (Colors are for dry soil unless otherwise stated.)

A--0 to 7 inches; grayish brown (10YR 5/2) silty clay loam, dark grayish brown (10YR 4/2) moist; moderate medium subangular blocky and fine granular structure; hard, firm; common fine and medium roots; common wormcasts; few weakly cemented fragments of chalk that are less than 10 mm in diameter; calcium carbonate equivalent is about 60 percent; calcareous, moderately alkaline; gradual smooth boundary. (5 to 13 inches thick)

Bk1--7 to 15 inches; light gray (10YR 7/2) silty clay loam, light brownish gray (10YR 6/2) moist; moderate fine subangular blocky structure; hard, firm; common fine roots; common wormcasts; few weakly cemented fragments of chalk that are less than 5 mm in diameter; calcium carbonate equivalent about 60 percent; calcareous, moderately alkaline; gradual wavy boundary. (7 to 20 inches thick)

Bk2--15 to 26 inches; very pale brown (10YR 7/3) silty clay loam, pale brown (10YR 6/3) moist; moderate fine subangular blocky structure; hard, firm; few fine roots; about 27 percent weakly cemented platy fragments of chalk that are slightly hard dry, but break down on wetting and gentle rubbing; calcium carbonate equivalent about 60 percent; few threads and films of calcium carbonate; calcareous, moderately alkaline; gradual wavy boundary. (4 to 17 inches thick.)

Cr--26 to 32 inches; white (10YR 8/1) weakly cemented platy chalk with few thin seams of very pale brown silty clay loam in the upper part in vertical fractures and between plates of chalk; rock structure, distinct horizontal bedding; slightly hard to hard when dry, but can be easily cut with spade when moist; hardness less than about 2 on Mohs scale; calcareous, moderately alkaline.

TYPE LOCATION: Grayson County, Texas; from the intersection of U. S. Highway 82 and Texas Highway 11 in Sherman, Texas; 3.9 miles southeast on Texas Highway 11 to Luella; 0.1 mile west on paved county road; south 1.7 miles on paved county road to gate at the Holloway Cemetery; 25 feet west of road right-of-way in pasture.

RANGE IN CHARACTERISTICS: Solum thickness ranges from 20 to 40 inches. Calcium carbonate equivalent of the control section ranges from 40 to about 80 percent. The texture of the soil is silty clay loam, silty clay or clay loam, with total clay content ranging from 30 to 45 percent and silicate clay content ranging from 25 to 35 percent.

The A horizon has colors with hue of 10YR, value of 4 to 6, and chroma of 2 or 3. Where moist values and chromas are less than 3.5, the A horizon is less than 7 inches thick. Fragments of weakly cemented chalk range from none to common.

The B horizons have colors with hue of 10YR or 2.5Y, value of 5 or 6, and chroma of 2 to 4. Some pedons have few to common yellow or brown mottles in the lower B horizon. The B horizons are silty clay loam, clay loam or silty clay. Pseudo rock fragments of chalk range from none to about 20 percent by volume in the upper B horizon and from about 5 percent 35 percent by volume in the lower B horizon. The fragments are hard to slightly hard when dry, but disintegrate upon overnight soaking in calgon and water. Platy fragments of calcite range from none to few.

The Cr horizon is white, light gray, very pale brown, or light brownish gray weakly cemented platy chalk or brittle marl. The upper few inches has thin seams of yellowish brown, brownish yellow, very pale brown, or pale yellow silty clay loam in fractures and between plates of chalk. The chalk becomes more massive and less fractured with depth. The chalk is easily cut with a spade when moist.

COMPETING SERIES: These include the Altoga and McLennan in the same family and the similar Austin, Brackett, Cuthand, Ellis, Lamar, Seawillow, and Whitewright series. Altoga, Lamar, McLennan and Seawillow soils lack a paralithic contact with chalk. In addition, Lamar soils have mixed mineralogy and Seawillow soils have fine-loamy control sections. Austin soils have mollic epipedons. Brackett and Whitewright soils have sola less than 20 inches thick. Cuthand soils have coarse-silty control sections. Ellis soils have COLE values of .09 or more and are noncalcareous.

GEOGRAPHIC SETTING: Howe soils are on upland ridges and upper sideslopes. Slope gradients are mostly 5 to 12 percent but range from 3 to 12 percent. The soil formed in weakly cemented marine chalk interbedded with marl, mainly of the Austin Group of Upper Cretaceous

Age. Mean annual precipitation ranges from about 35 to 41 inches. The mean annual temperature ranges from 63 degrees to 66 degrees F. and the Thornthwaite P-E index ranges from 56 to 66.

GEOGRAPHICALLY ASSOCIATED SOILS: These include the competing Altoga, Austin, and Whitewright series and the Eddy, Fairlie and Lewisville series. Altoga and Lewisville soils are on lower lying stream terraces. Lewisville soils have mollic epipedons and lack a paralithic contact with chalk. Austin and Fairlie soils are on higher lying uplands. Fairlie soils have intersecting slickensides and wide cracks when dry. Eddy and Whitewright soils are in similar positions.

DRAINAGE AND PERMEABILITY: Well drained; medium runoff; moderate permeability.

USE AND VEGETATION: Used mostly for pasture. The main grasses are common and improved bermudagrass and K. R. bluestem. Native vegetation includes little bluestem, silver bluestem, sideoats grams, Texas wintergrass, threeawn with scattered elm and oak trees. A few areas are cultivated with cotton, small grain, and grain sorghum being the main crops grown.

DISTRIBUTION AND EXTENT: The Blackland Prairie of north-central Texas. The soil is moderately extensive.

MLRA OFFICE RESPONSIBLE: Temple, Texas

SERIES ESTABLISHED: Grayson County, Texas; 1977.

REMARKS: Howe soils have formerly been included in the Austin series.

Classification was changed 11/89 from Typic Ustochrepts to Udic Ustochrepts.

Diagnostic horizons and features recognized in this pedon are:

Ochric epipedon - 0 to 7 inches, the A horizon.

Cambic horizon - 7 to 26 inches the Bk horizon.

Paralithic contact of chalk at a depth of 26 inches.

National Cooperative Soil Survey, U.S.A.

LESON SERIES

The Leson series consists of very deep, moderately well drained, very slowly permeable soils that formed in alkaline shales and clays. These soils are on nearly level or gently sloping uplands. Slopes range from 0 to 5 percent.

TAXONOMIC CLASS: Fine, smectitic, thermic Udic Haplusterts

TYPICAL PEDON: Leson clay--cropland. Midway between microhigh and microlow. (Colors are for dry soil unless otherwise stated.)

Ap--0 to 10 inches; very dark gray (10YR 3/1) clay, black (10YR 2/1) moist; moderate fine angular blocky structure; on the surface there is a one-half inch layer that has moderate medium granular structure; extremely hard, very firm; common shiny pressure faces; few fine black concretions; moderately alkaline; gradual wavy boundary. (3 to 20 inches thick)

Bss--10 to 30 inches; very dark gray (10YR 3/1) clay, black (10YR 2/1) moist; weak coarse angular blocky structure parting to moderate medium angular blocky; extremely hard, very firm; common intersecting slickensides and wedge-shaped peds having long axis tilted 30 to 45 degrees from the horizontal; few fine iron-manganese concretions; moderately alkaline; gradual wavy boundary. (6 to 40 inches thick)

Bkss--30 to 60 inches; pale olive (5Y 6/3) clay, olive (5Y 5/3) moist; common medium and coarse distinct very dark gray (10YR 3/1) and many fine faint light olive brown (2.5Y 5/6) mottles; moderate fine angular blocky structure; very hard, firm; common slickensides; common fine and medium calcium carbonate concretions and few masses of calcium carbonate; lower part of layer contains few shale fragments; slightly effervescent; moderately alkaline; gradual wavy boundary. (15 to 30 inches thick)

Ck--60 to 80 inches; olive gray (5Y 5/2) weakly consolidated shale that has clay texture; with alternating layers of light olive brown (2.5Y 5/6); evident bedding planes; extremely hard, very firm; few slickensides; contains approximately 10 percent calcium carbonate in the form of concretions and masses; few iron-manganese concretions; strongly effervescent; moderately alkaline.

TYPE LOCATION: Hopkins County, Texas; from intersection of Texas Highway 11 and 19 in Sulphur Springs, 10.8 miles west on Highway 11; 225 feet north in field.

RANGE IN CHARACTERISTICS: Solum thickness range from 60 to 80 inches. The weighted average clay content of the particle size control section ranges from 40 to 60 percent. When dry cracks 1/2 to 3 inches extend from the surface to a depth of more than 12 inches. In undisturbed areas there is gilgai microrelief. Distance between the microknoll and microdepression ranges from 4 to about 16 feet. There are few to many slickensides below a depth of about 15 inches. About 55 to 80 percent of the pedon has matrix colors of chroma 2 or more within 40 inches of the soil surface. Carbonates are below the A horizon and ranges from 9 to 60 inches.

The A horizons have hue of 10YR to 5Y and N, value of 2 to 4, and chroma of 0 or 1. Some pedons contain a few mottles in colors and shades of brown and olive in the lower part. The A horizon ranges from 12 to 20 inches thick on microknolls and 30 to 60 inches thick in microdepressions. It is clay or silty clay and is slightly acid to moderately alkaline.

The Bss horizons have hue of 10YR to 5Y, value of 2 and chroma of 0 to 1 in the upper part and value of 3 to 5, and chroma of 2 to 4 in the lower part. There are few to many mottles in colors and shades of gray, brown, and yellow. It is calcareous or noncalcareous clay or silty clay and typically contains few to common calcium carbonate concretions and soft masses. The Bkss horizon is neutral to moderately alkaline.

The Ck horizon has hue of 10YR to 5Y, value of 4 to 6 and chroma of 2 to 6. It is stratified clay and weakly consolidated shale; bedding planes are evident in most pedons. Few to common concretions and soft masses of calcium carbonate are in most pedons. Gypsum crystals range from none to common. The Ck horizon is mildly or moderately alkaline.

COMPETING SERIES: These are the Bleiberville, Branyon, Burleson, Clarita, Dimebox, Fairlie, Heiden, Houston Black, Luling, Ovan, Sanger, Slidell, Tamford and Watonga series. Bleiberville, Branyon, Fairlie, Heiden, Houston Black, Ovan, Sanger, and Slidell are calcareous in the surface layer. Burleson soils have matrix chromas of 1 or less throughout the upper 40 inches. Clarita and Tamford soils have hue of 7.5YR or redder in the subsoil. Dimebox soils have ironstone pebbles and contain calcium sulfate in all parts of the pedon. Fairlie soils are underlain by chalk at 40 to 60 inches depth. Luling soils have chroma of 1.5 or more in the surface layers. Watonga soils have sola less than 60 inches thick, and are in slightly cooler climates.

GEOGRAPHIC SETTING: Leson soils are on nearly level to gently sloping uplands. Slope gradients range from 0 to 5 percent, but mainly are 1 to 3 percent. The soil formed in alkaline shales and clays. The climate is warm and subhumid. The mean annual precipitation ranges from 34 to 44 inches and mean annual average temperature ranges from 63 to 70 degrees F. Frost free days range from 230 to 260 days and elevation ranges from 350 to 750 feet. Thornthwaite annual P-E indices are 44 to 72.

GEOGRAPHICALLY ASSOCIATED SOILS: These are the competing Branyon, Burleson, Houston Black and Heiden in the same family, also the Ferris and Wilson series. Heiden and Ferris soils have A horizons with chroma 1 or 2. Wilson soils have loamy surface layers and firm textured Bt horizons. Ferris, Heiden, and Houston Black are on higher areas. Branyon, Burleson and Wilson are in similar or slightly lower positions.

DRAINAGE AND PERMEABILITY: Moderately well drained. Runoff is medium; Permeability is very slow. Water enters the soil rapidly when it is dry and cracked, and very slowly when it is moist.

USE AND VEGETATION: Mainly cultivated and used for crops such as cotton, grain sorghums, and corn. Native grasses are mainly bluestem, indiagrass, and gramas. Improved pastures are planted to bermudagrass and lovegrass. Scattered trees include bois d'arc, hackberry, elm, post oak, and locust.

DISTRIBUTION AND EXTENT: The Blackland Prairies of Texas. The series is extensive.

MLRA OFFICE RESPONSIBLE: Temple, Texas

SERIES ESTABLISHED: Hopkins County, Texas; 1973.

REMARKS: The soil was formerly included in the Burleson or Hunt series.

Diagnostic horizons and features recognized in this pedon are:

Mollic epipedon - 0 to 30 inches

cambic horizon - 30 to 60 inches.

Vertic features - Slickensides at a depth of 10 to 60 inches. High shrink-swell potential and cracks that are 1/2 to 3 inches wide at a depth of 12 inches or more during dry periods.

SIR Number. TX0074

National Cooperative Soil Survey, U.S.A.

NORMANGEE SERIES

The Normangee series consists of soils that are deep to weakly consolidated shale. They are moderately well drained, very slowly permeable soils that formed in Cretaceous Age clay materials. These soils are on nearly level to moderately sloping uplands. Slopes range from 0 to 8 percent.

TAXONOMIC CLASS: Fine, smectitic, thermic Udertic Haplustalfs

TYPICAL PEDON: Normangee clay loam - pastureland. (Colors are for dry soil unless otherwise stated.)

Ap--0 to 7 inches; dark grayish brown (10YR 4/2) clay loam, very dark grayish brown (10YR 3/2) moist; weak medium angular blocky structure; very hard, firm; few dark ferromanganese concretions and few rounded pebbles of quartz; slightly acid; clear wavy boundary. (4 to 9 inches thick)

Bt1--7 to 18 inches, brown (10YR 5/3) clay, dark brown (10YR 4/3) moist; few fine distinct mottles of yellowish brown (10YR 5/6), dark grayish brown (10YR 4/2), and reddish brown (5YR 4/4); moderate medium angular blocky structure; extremely hard, extremely firm; few fine ferromanganese concretions and pebbles of quartz; distinct clay films on peds; medium acid; gradual smooth boundary. (8 to 16 inches thick)

Bt2--18 to 34 inches; brown (10YR 5/3) clay, brown (10YR 4/3) moist; few fine faint mottles of olive brown and yellowish brown; moderate medium and fine angular blocky structure; distinct

clay films on peds; extremely hard, extremely firm; distinct clay films on face of peds; neutral; gradual smooth boundary. (12 to 20 inches thick)

Bt3--34 to 44 inches, light yellowish brown (2.5Y 6/4) clay, light olive brown (2.5Y 5/4) moist; common fine and medium distinct mottles of yellowish brown (10YR 5/8) and olive yellow (2.5Y 6/8); weak fine angular blocky structure; extremely hard, extremely firm; few clay films; few fine soft masses of calcium carbonate; moderately alkaline; gradual smooth boundary. (6 to 15 inches thick)

Ck--44 to 64 inches; very pale brown (10YR 7/3) weakly consolidated shale; that has clay texture; yellowish brown (10YR 5/4) moist; massive; few fine distinct mottles of brownish yellow and brown; extremely hard, very firm; common soft masses of calcium carbonate up to about 1/2 inch. i. size; moderately alkaline.

TYPE LOCATION: Anderson County, Texas; about 4.0 miles northwest of Cayuga; about 1.5 miles west of Cayuga, 1.8 miles north of U.S. Highway 287 and 1.75 miles west on county road.

RANGE IN CHARACTERISTICS: Solum thickness ranges from 40 to 60 inches. Depth to secondary carbonates is greater than 30 inches. Some pedons lack visible carbonates. The clay content of the control section averages 40 to 50 percent. The COLE values range from .07. to .10 The soil has cracks 1/2 inch wide to a depth of more than 20 inches when dry.

The A horizon has hue of 7.5YR or 10YR, value of 4 to 6, and chroma of 2 to 4. The texture is sandy clay loam, loam, clay loam or their gravelly counterparts. It is hard or very hard when dry. Reaction ranges from medium acid to neutral.

The upper Bt horizon has matrix with hue of 5YR, 7.5YR to 10YR, value of 4 or 5, and chroma of 3 or 4. Reddish and brownish mottles range from few to common. Lower Bt horizons are in shades of brown or olive in hue of 10YR or 2.5Y with or without mottles in shades of yellow, brown, or red. The texture of the Bt horizon is clay, however, some pedons have clay loam lower B horizons. Reaction of the upper Bt horizon ranges from medium acid to moderate;y alkaline. Reaction of the lower Bt horizon ranges from slightly acid to moderately alkaline. Some pedons are calcareous in the lower part. Calcium carbonate in the form of concretions and masses ranges from none to common.

The C horizon is weakly consolidated shale with clay texture that is stratified with clay loam, clay and shaly clay. Colors are in shades of gray, olive, yellow and brown. The reaction ranges from neutral to moderately alkaline. Some pedons are calcareous. Visible carbonates range from none to common.

COMPETING SERIES: There are no other series in the same family. Similar soils are the Axtell, Bazette, Chaney, Crockett, Payne, Ponder and Steedman series. Axtell, Chaney, and Crockett soils have an abrupt texture change between the A and Bt horizon. Bazette and Payne soils lack vertic properties. Ponder soils have sola more than 60 inches thick and Steedman soils have sola 20 to 40 inches thick.

GEOGRAPHIC SETTING: Normangee soils occur on nearly level to moderately sloping uplands. Slope gradients are predominantly 1 to 6 percent, but range from 0 to 8 percent. The soil formed in alkaline marine sediments of shale, clay, and sandy clay underlain in places by sandstone or limestone. Mean annual temperature ranges from 67 F. and mean annual precipitation ranges from 32 to 42 inches. Frost free days range from 220 to 270 days and elevation ranges from 350 to 800 feet. Thornthwaite annual P-E indices are 50 to 70.

GEOGRAPHICALLY ASSOCIATED SOILS: These include the competing Axtell and Crockett series and the Ellis and Wilson soils. Axtell and Crockett soils are on similar positions. The Ellis soils are clayey throughout and are on similar or more sloping positions. Wilson soils are gray throughout and are on flat, wetter positions.

DRAINAGE AND PERMEABILITY: Moderately well drained. Runoff is slow to rapid; Permeability is very slow.

USE AND VEGETATION: Principal use is pasture. A few areas are farmed to cotton, grain sorghum, small grain, or corn. Native vegetation is thin strands of post oak with bluestems, Indiangrass, switchgrass, and grama grasses in open areas.

DISTRIBUTION AND EXTENT: Blackland Prairie and Texas Claypan areas; possibly in the Cross Timbers areas of Texas and Oklahoma. The series is of moderate extent.

MLRA OFFICE RESPONSIBLE: Temple, Texas

SERIES ESTABLISHED: Anderson County, Texas; 1970.

REMARKS: Formerly included in the Crockett and Payne series.

Diagnostic horizons and features recognized in this pedon are:

Ochric epipedon - 0 to 7 inches, the Ap horizon. (Ap horizon)

Argillic horizon - 7 to 44 inches the Bt horizon. (the Bt horizons)

Soil has high shrink-swell, and cracks when dry.

National Cooperative Soil Survey, U.S.A.

STEPHEN SERIES

The Stephen series consists of shallow, well drained, moderately slowly permeable soils formed in interbedded marl and chalky limestone. These soils are on gently sloping to sloping uplands. Slopes are mainly 1 to 5 percent but range from 1 to 8 percent.

TAXONOMIC CLASS: Clayey, mixed, active, thermic, shallow Udorthentic Haplustolls

TYPICAL PEDON: Stephen silty clay--cropland. (Colors are for dry soil unless otherwise stated.)

Ap--0 to 8 inches; dark brown (7.5YR 4/2) silty clay, dark brown (7.5YR 3/2) moist; moderate fine subangular blocky and granular structure parting to very fine subangular blocky structure; hard, firm, sticky, plastic; many fine roots; few fine chalk fragments; calcareous, moderately alkaline; abrupt wavy boundary. (7 to 20 inches thick)

C/A--8 to 12 inches; about 65 percent platy chalk fragments and platy chalk in place and about 35 percent dark brown (7.5YR 3/3) moist silty clay in the horizontal and vertical crevices and between the loose chalk fragments; few to strongly cemented cobbles and limestone; few fine roots; few fine pores; calcareous, moderately alkaline; abrupt irregular boundary. (0 to 6 inches thick)

Cr--12 to 28 inches; pink (5YR 8/3) and white (10YR 8/2) platy chalk this is less hard than 3, Mohs scale; few thin tongues of dark brown calcareous silty clay in crevices between some chalk plates.

TYPE LOCATION: McLennan County, Texas; from the intersection of Farm Road 1695 and Farm Road 2837 in Lorena, 0.6 mile northwest on Farm Road 2837 to intersection with county road, 300 feet west and 100 feet north of intersection in cropland.

RANGE IN CHARACTERISTICS: Solum thickness to chalky limestone ranges from 7 to 20 inches. The chalky limestone, when moist, can be cut with a spade. The layer below the A horizon ranges from 40 to 80 percent or more calcium carbonate equivalent.

The A horizon has hue of 7.5YR or 10YR; value of 3 to 5, and chroma of 1 to 3. It is clay, silty clay, silty clay loam, or clay loam with 35 to 55 percent clay. Chalk fragments in the A horizon range from 2 to 15 percent by volume. Olive mottles or streaks range from none to common in the lower part to the A horizon. The lower boundary of the A horizon ranges from wavy to irregular.

The C/A or A/C horizons, where present, have color and texture similar to those of the A and Cr horizons.

The Cr horizon is interbedded chalk and limy earths or soft limestone and limy earths. It has hue of 5YR to 10YR in shades of pink, white, and gray.

COMPETING SERIES: There are no series in the same family. Similar soils are Brackett, Castephen, Doss, Eckrant, Purves, Real, and Whitewright series. Brackett and Whitewright soils lack a mollic epipedon. Brackett, Castephen, Doss, Real, and Whitewright soils have carbonatic mineralogy and contain less than 35 percent silicate clay. Eckrant and Purves soils have a Lithic contact with indurated limestone. In addition, Eckrant and Real soils contain more than 35 percent coarse fragments.

GEOGRAPHIC SETTING: Stephen soils are on uplands. Surfaces are plane to convex, with gradients mainly less than 5 percent, but range from 1 to 8 percent. The soils formed in interbedded chalk, marl, or soft limestone rubble, mainly of the Austin Formation. The climate is warm and subhumid; mean annual precipitation ranges from 30 to 42 inches, mean annual temperature from 63 to 69 degrees F., and the Thornthwaite annual P-E indices from 44 to 66.

GEOGRAPHICALLY ASSOCIATED SOILS: These are the Altoga, Austin, Brackett, Eddy, and Lott series. All of these soils have carbonatic

mineralogy and less than 35 percent clay in the control section. In addition; Altoga, Brackett, and Eddy do not have mollic epipedons.

DRAINAGE AND PERMEABILITY: Well drained; medium to rapid runoff; medium internal drainage; moderately slow permeability.

USE AND VEGETATION: Mainly in cultivation and used for growing small grains. A few areas are in native range. Native grasses are little bluestem, sideoats grama, hairy grama, and buffalograss.

DISTRIBUTION AND EXTENT: The Blackland Prairie of Texas. The series is extensive.

MLRA OFFICE RESPONSIBLE: Temple, Texas

SERIES ESTABLISHED: Ellis County, Texas; 1962.

REMARKS: Classification was changed 11/89 from clayey, mixed, thermic, shallow Entic Haplustolls to clayey, mixed, thermic, shallow Udorthentic Haplustolls.

Diagnostic horizons and features recognized in this pedon are:

Mollic epipedon - 0 to 8 inches, the Ap horizon.

Paralithic contact of chalk at a depth of 12 inches.

National Cooperative Soil Survey, U.S.A.

TRINITY SERIES

The Trinity series consists of very deep, moderately well drained, very slowly permeable soils on flood plains. They formed in alkaline clayey alluvium. Slopes are typically less than 1 percent, but range from 0 to 3 percent.

TAXONOMIC CLASS: Very-fine, smectitic, thermic Typic Hapluderts

TYPICAL PEDON: Trinity clay--pasture. (Colors are for moist soil unless otherwise stated.)

Ap--0 to 6 inches; very dark gray (5Y 3/1) clay, dark gray (5Y 4/1) dry; moderate fine and medium granular and moderate fine subangular blocky structure; very hard, firm, sticky, very plastic; many fine roots; common fine pores; strongly effervescent; moderately alkaline; clear smooth boundary. (0 to 8 inches thick)

A--6 to 16 inches; very dark gray (5Y 3/1) clay, dark gray (5Y 4/1) dry; moderate medium subangular blocky structure parting to very fine subangular blocky; very hard, firm, sticky, very plastic; common fine roots; common fine pores; many prominent pressure faces; few very fine concretions of calcium carbonate; strongly effervescent, moderately alkaline; gradual wavy boundary. (8 to 24 inches thick)

Bss1--16 to 36 inches; very dark gray (5Y 3/1) clay, dark gray (5Y 4/1) dry; weak fine and very fine subangular blocky structure; very hard, firm, sticky, very plastic; few fine roots; few fine pores; many prominent pressure faces; common prominent grooved slickensides that increase with depth; few very fine and fine concretions of calcium carbonate; strongly effervescent; moderately alkaline; diffuse wavy boundary.

Bss2--36 to 64 inches; very dark gray (5Y 3/1) clay, dark gray (5Y 4/1) dry; weak coarse blocky structure; very hard, very firm; few fine roots and pores; many prominent grooved slickensides; common fine and medium distinct olive yellow (5Y 6/6) and yellowish brown (10YR 5/8) redox concentrations; common fine and medium concretions of calcium carbonate; few hard black concretions; strongly effervescent; moderately alkaline; diffuse wavy boundary.

Bss3--64 to 75 inches; dark olive gray (5Y 3/2) clay, olive gray (5Y 4/2) dry; weak coarse angular blocky structure; very hard, very firm; common fine and medium distinct olive yellow (2.5Y 6/6; 5Y 6/8) and few coarse distinct light olive brown (2.5Y 5/4) redox concentrations; few prominent slickensides; common very fine and medium concretions of calcium carbonate; common fine black concretions; strongly effervescent, moderately alkaline. (combined thickness of Bss horizons is 40 to 70 inches)

TYPE LOCATION: Kaufman County, Texas; from intersection of old U.S. Hwy. 80 and Farm Road 740 in Forney; 6.1 miles south on Farm Road 740; 0.45 mile south on oil top road which is an extension of Farm Road 740; 54 feet east of fence.

RANGE IN CHARACTERISTICS: Solum thickness is more than 80 inches. Gilgai microrelief is present in undisturbed areas but is subdued with the micro highs 2 to 6 inches higher than the micro lows. When dry, cracks 1/4 to more than 1 inch wide extend to a depth of 20 inches or more for less than 90 cumulative days. Grooved slickensides typically begin at a depth of 12 to 24 inches and increase in number and size with depth. Clay content of the control section ranges from 60 to 80 percent. The soil is slightly alkaline or moderately alkaline and slightly or strongly effervescent throughout.

The A horizon has hue of 10YR, 2.5Y, or 5Y, with values of 2 to 3 and chroma of 1.

The Bss or Bkss horizons have hue of 10YR, 2.5Y, or 5Y, value of 2 to 5, and chroma of 2 or less. Few to common masses of redox concentrations in shades of yellow, brown, or olive are in the lower part. Calcium carbonate in the form of masses, concretions, and threads range from none to common.

COMPETING SERIES: These are the Billyhaw, Kaufman, and Wiergate series in the same family and the Hallsbluff, Kaman, Pledger, Texark, Tinn, and Zilaboy series in similar families. The Billyhaw soils have a solum less than 60 inches thick and colors with hue redder than 10YR. Kaman, Kaufman, Texark, and Wiergate soils are noncalcareous in the A horizon. Hallsbluff, Kaman, Tinn, and Zilaboy soils average less than 60 percent clay in the particle-size control section. Kaman and Zilaboy soils are wet for longer periods. Pledger soils have a hyperthermic temperature regime and, in addition, Pledger soils have sola less than 60 inches thick and colors with hue redder than 10YR.

GEOGRAPHIC SETTING: Trinity soils are on nearly level, wide flood plains of major rivers and streams. Slopes are mainly less than 1 percent but range up to 3 percent. The soil formed in calcareous clayey alluvium. The climate is warm and humid to subhumid. The mean annual precipitation ranges from 34 to 52 inches and mean annual temperatures range from 62 to 70 degrees F. Frost free days range from 230 to 280 days and elevation ranges from 100 to 550 feet. Thornthwaite P-E indices range from 52 to about 70.

GEOGRAPHICALLY ASSOCIATED SOILS: These are the competing Kaufman, Tinn, and Zilaboy series and the Gladewater and Ovan series. Ovan soils have less than 60 percent clay in the particle-size control section, have colors with chroma of 2 or 3 in the A horizon, and have cracks that stay open longer than 90 cumulative days. Gladewater soils have aquic soil conditions within a depth of 20 inches. Gladewater and Zilaboy soils are on slightly lower and wetter positions. Kaufman, Tinn, and Ovan soils are on similar flood plain positions.

DRAINAGE AND PERMEABILITY: Moderately well drained. Runoff is low on 0 to 1 percent slopes and medium on 1 to 3 percent slopes. Permeability is very slow. Flooding is common except where the soil is protected.

USE AND VEGETATION: Most areas are in pasture or planted to crops such as cotton, corn, sorghums, or small grains. Native vegetation is hardwood forest of elm, hackberry, oak, and ash.

DISTRIBUTION AND EXTENT: North Central, Central, and South Central Texas. The series is extensive.

MLRA OFFICE RESPONSIBLE: Temple, Texas

SERIES ESTABLISHED: Monroe County, Mississippi; 1908.

REMARKS: Diagnostic horizons and features recognized in this pedon are:

Mollic epipedon - the A horizon from 0 to 16 inches. Cambic horizon - the Bss horizon from 16 to 75 inches. Vertic properties - gilgai microrelief in undisturbed areas, slickensides at a depth of 16 to 75 inches, and cracks that remain open less than 90 cumulative days.

ADDITIONAL DATA: National Soil Survey Laboratory: S77TX-175-(78P068).

Soil Interpretation Record - Trinity (TX0101), commonly flooded (TX1189), frequently flooded (TX1124), depressional (TX0919).

National Cooperative Soil Survey, U.S.A.

TINN SERIES

The Tinn series consists of very deep, moderately well drained, very slowly permeable soils that formed in calcareous clayey alluvium. These soils are on flood plains of streams that drain the Blackland Prairies. Slopes are dominantly less than 1 percent but range from 0 to 2 percent.

TAXONOMIC CLASS: Fine, smectitic, thermic Typic Hapluderts

TYPICAL PEDON: Tinn clay--cultivated. (Colors are for moist soil unless otherwise noted.)

Ap--0 to 6 inches; black (10YR 2/1) clay, very dark gray (10YR 3/1) dry; moderate coarse angular blocky structure parting to moderate very fine and fine angular blocky structure; very hard, very firm; plastic; few fine roots; few fine and medium pores; slightly effervescent; moderately alkaline; abrupt smooth boundary. (4 to 8 inches thick)

A--6 to 18 inches; black (10YR 2/1) clay, very dark gray (10YR 3/1) dry; moderate coarse angular blocky structure parting to moderate very fine and fine angular blocky; very hard, very firm; few fine roots; few fine and medium pores; common pressure faces; few fine slickensides; about 2 percent fine siliceous pebbles, and about 2 percent fine ironstone pebbles; few worm casts; few medium grayish brown (2.5Y 5/2) streaks along root channels; slightly effervescent; moderately alkaline; gradual wavy boundary. (6 to 15 inches thick)

Bss1--18 to 28 inches; black (10YR 2/1) clay, very dark gray (10YR 3/1) dry; moderate coarse angular blocky structure parting to moderate fine and medium angular blocky; very hard, very firm; few fine roots; few fine and medium pores; common fine pressure faces; common fine slickensides; about 2 percent fine siliceous pebbles, and about 2 percent fine ironstone pebbles; few worm casts; few medium grayish brown (2.5Y 5/2) streaks along root channels; slightly effervescent; moderately alkaline; gradual wavy boundary. (8 to 20 inches thick)

Bss2--28 to 54 inches; black (10YR 2/1) clay, very dark gray (10YR 3/1) dry; moderate coarse angular blocky structure parting to moderate fine and medium angular blocky structure; very hard, very firm; few fine roots; few fine and medium pores; many prominent grooved

slickensides that range from 5 to 10 cm across; most slickensides are oriented at 45 degrees; few fine black concretions; few medium calcium carbonate concretions that are pitted; about 2 percent siliceous pebbles; about 2 percent shell fragments; few worm casts; few coarse very dark gray (10YR 3/1) masses; slightly effervescent; moderately alkaline; gradual wavy boundary. (0 to 30 inches thick)

Bss3--54 to 72 inches; very dark gray (10YR 3/1) clay, dark gray (10YR 4/1) dry; moderate coarse angular blocky structure parting to moderate fine and medium angular blocky; very hard, very firm; few fine roots; few fine and medium pores; common prominent grooved slickensides up to 1 meter across, slickensides are oriented at 45 to 60 degrees; few fine and medium calcium carbonate concretions that are pitted; few worm casts; slightly effervescent; moderately alkaline; gradual wavy boundary. (10 to 24 inches thick)

Bkss--72 to 80 inches; very dark grayish brown (2.5Y 3/2) clay, dark grayish brown (2.5Y 4/2) dry, moderate coarse angular blocky structure parting to moderate fine and medium angular blocky; very hard, very firm; few fine roots; few fine and medium pores; few fine grooved slickensides up to 50 cm across, slickensides are oriented at 45 to 60 degrees; common fine and medium calcium carbonate concretions; few fine and medium masses of gypsum; few black (10YR 2/1) streaks; slightly effervescent; moderately alkaline.

TYPE LOCATION: Limestone County, Texas; from the intersection of Farm Road 171 and Farm Road 73 in Coolidge, 2.8 miles northeast on Farm Road 73, 0.6 miles north on county road, and 400 feet east on Pin Oak Creek floodplain in cropland.

RANGE IN CHARACTERISTICS: Solum thickness is greater than 80 inches. Reaction is slightly alkaline or moderately alkaline. Effervescence ranges from very slight to strong. Weighted average clay content of the particle size control section ranges from 40 to 60 inches. Texture is silty clay or clay throughout. Undisturbed areas have subdued gilgai, with microhighs 2 to 6 inches higher than microlows. Slickensides and/or wedge-shaped aggregates begin at depths from 6 to 20 inches, becoming more distantly expressed between 20 and 60 inches. The soil cracks when dry and the cracks are 0.5 inch to about 2 inches wide and extend to a depth of more than 12 inches. The cracks remain open from 60 to 90 cumulative days in most years.

The A horizon has dark colors in hue of 10YR to 5Y, value of 2 or 3, and chroma of 1. Texture is silty clay or clay.

A Bw horizon is present in some pedons. Where present, the colors and textures are similar to those of the A horizon.

The Bss and Bkss horizons have hue of 10YR to 5Y, value of 3 to 6, and chroma of 1 to 4. Redox concentrations in shades of brown, olive or yellow range from none to common. Calcium carbonate masses and concretions range from none to common.

COMPETING SERIES: These are the Eastham and Hallsbluff series. Similar soils are the Branyon, Burleson, Kaufman, and Trinity soils. Eastham soils are not calcareous in the upper 20 inches. Hallsbluff soils have a mollic epipedon with chroma of 2. Branyon and Burleson soils are

Usterts. In addition, Burleson soils are noncalcareous in the upper 20 inches. Kaufman and Trinity soils have very-fine control sections.

GEOGRAPHIC SETTING: Tinn soils are on nearly level flood plains. Slopes are mainly less than 1 percent, but some are as much as 2 percent. The soil formed in calcareous clayey alluvium. Mean annual precipitation ranges from 32 to 42 inches, and mean annual temperature ranges from 64 to 68 degrees F. Frost free days range 230 to 270 days and elevation ranges from 250 to 550 feet. Thornthwaite P-E indices exceed 44.

GEOGRAPHICALLY ASSOCIATED SOILS: These are the Branyon, Burleson, Ferris, Heiden, Houston Black, and Trinity series. Branyon and Burleson soils are on higher terrace positions. Ferris and Heiden soils have chroma of 2 or more in the upper 12 inches. Houston Black soils have greater amplitude of waviness and are on uplands in a higher position. Trinity soils have very-fine particle-size control sections and are in similar positions.

DRAINAGE AND PERMEABILITY: Moderately well drained. Permeability is very slow. Runoff is low. Flooding is common except where the soil is protected. Duration of flooding is very brief or brief.

USE AND VEGETATION: Most areas are in pasture or cultivated to crops such as cotton, corn, sorghums, or small grains. Native vegetation is elm, hackberry, oak, and ash, with an understory of grasses such as species of paspalums and panicums.

DISTRIBUTION AND EXTENT: Mainly in central Texas on streams draining the Blackland Prairies (MLRA 86A). The series is extensive.

MLRA OFFICE RESPONSIBLE: Temple, Texas

SERIES ESTABLISHED: Hill County, Texas; 1975.

REMARKS: Classification of the Tinn series was changed from Vertic Haplaquolls to Typic Pelluderts (3/88). This change was based on several years study and analysis of the soils mapped in the Tinn series. The series type location was moved from Hill County to Limestone County to a pedon that is near the center of the series range in characteristics and near the center of the geographic distribution. Classification change from Typic Pelluderts to Typic Hapluderts based on Amendment 16, SOIL TAXONOMY (2/94).

Diagnostic horizons and features recognized in this pedon are:

Mollic colors - throughout this pedon.

Vertic Properties - slickensides from 6 to 80 inches.

SOIL INTERPRETATION RECORD NO: TX0456

National Cooperative Soil Survey, U.S.A.

WILSON SERIES

The Wilson series consists of very deep, moderately well drained, very slowly permeable soils that formed in alkaline clayey sediments. These soils are on nearly level to gently sloping stream terraces or terrace remnants on uplands. Slopes are mainly less than 1 percent but range from 0 to 5 percent.

TAXONOMIC CLASS: Fine, smectitic, thermic Oxyaquic Vertic Haplustalfs

TYPICAL PEDON: Wilson silt loam--cropland. (Colors are for moist soil unless otherwise stated.)

Ap--0 to 5 inches; very dark gray (10YR 3/1) silt loam, gray (10YR 5/1) dry; weak fine granular structure; massive when dry; very hard, firm, sticky and plastic; common fine roots; moderately acid; abrupt wavy boundary. (3 to 10 inches thick)

Bt--5 to 20 inches; very dark gray (10YR 3/1) silty clay, gray (10YR 5/1) dry; moderate medium angular blocky structure; extremely hard, very firm, very sticky and very plastic; few fine roots; few fine pores; thin continuous clay films 1/2 unit of value darker than interior of peds; vertical cracks 1/2 inch wide are filled with material from the Ap horizon; slightly acid; gradual wavy boundary. (10 to 20 inches thick)

Btssg1--20 to 32 inches; grayish brown (2.5Y 5/2) silty clay, light brownish gray (2.5Y 6/2) dry; moderate medium angular blocky structure; extremely hard, very firm, very sticky and very plastic; few fine roots; few fine pores; few slickensides; few medium pressure faces; thin continuous clay films on surface of peds; vertical cracks 1/4 inch wide partly filled with material from above; few fine crystals of gypsum; few fine calcium carbonate concretions; slightly alkaline; diffuse wavy boundary.

Btssg2--32 to 65 inches; grayish brown (2.5Y 5/2) silty clay, light brownish gray (2.5Y 6/2) dry; weak coarse angular blocky structure; extremely hard, very firm, very sticky and very plastic; few fine roots; few fine pores; few slickensides; patchy clay films on surface of peds; common fine crystals of gypsum; few fine masses of calcium carbonate; slightly alkaline; gradual smooth boundary. (combined Btss subhorizons are 25 to 60 inches thick)

BCKss--65 to 80 inches; olive gray (5Y 5/2) silty clay, light gray (5Y 7/2) dry; weak coarse angular blocky structure; extremely hard, very firm, very sticky and very plastic; few fine roots; few fine pores; few slickensides; few coarse masses of calcium carbonate; few small fragments of clay; very slightly effervescent; moderately alkaline.

TYPE LOCATION: Kaufman County, Texas; 4 miles southeast of the intersection of Texas Highway 34 and U. S. Highway 175 in Kaufman, 0.15 mile northeast and 0.2 mile southeast of intersection of county road and U. S. Highway 175, 150 feet southwest in field.

RANGE IN CHARACTERISTICS: Solum thickness ranges from 60 to more than 80 inches. The weighted average clay content of the upper 20 inches of the argillic horizon ranges from 35 to 50 percent. When dry, cracks at least 1/4 inch wide extend from the top of the argillic horizon through a thickness of 12 inches or more within the upper 50 inches of the soil. Slickensides and/or wedged-shaped aggregates and pressure faces range from few to common and begin at a depth of 14 to 26 inches. Linear extensibility is greater than 2.5 inches (6 cm) within 40 inches (100 cm) of the soil surface. COLE ranges from 0.07 to 0.10 in the upper 50 inches of the argillic horizon. The surface layer is variable in thickness with a series of micro crests and troughs in the Bt horizon that range from 4 to about 20 feet apart. Redoximorphic features are contemporary in the upper Bt1 horizon and are mainly relic in the lower part of the Bt horizon. The soil does not have aquic soil conditions in the upper 20 inches in most years.

The A horizon is less than 10 inches thick in more than 50 percent of the pedon, but it is as much as 15 inches thick in some subsoil troughs. It has hue of 10YR or 2.5Y, value of 3 to 5, and chroma of 1 or 2. Texture is loam, silt loam, silty clay loam, clay loam or their gravelly counterparts. Siliceous pebbles and small cobbles range from 0 to 35 percent. It is massive and hard or very hard when dry but is soft or friable with structure when moist. Some pedons have a thin E horizon in subsoil troughs. Reaction ranges from moderately acid to neutral.

The Bt horizon has hue of 10YR or 2.5Y, value of 2 to 4, and chroma of 1 or less. Texture is clay loam, silty clay loam, silty clay, or clay. Some pedons have iron concentrations in shades of brown or yellow that range from few to common. Siliceous pebbles range from 0 to about 15 percent by volume. Reaction ranges from slightly acid to slightly alkaline.

The Btss horizon has hue of 10YR to 5Y, value of 3 to 7, and chroma of 2 or less. Iron concentrations in shades of yellow, brown or olive range from none to common. Texture is commonly silty clay or clay and less commonly silty clay loam or clay loam. Reaction ranges from moderately acid to slightly alkaline and is typically noncalcareous.

The Bck or BC horizon has colors in shades of gray or brown. Redoximorphic features of these colors and in other shades of yellow, red or olive range from few to many. Texture is clay loam, silty clay loam, silty clay, or clay. Some pedons have fragments or thin strata of shale or marl. These materials make up less than 35 percent of the matrix. Reaction ranges from neutral to moderately alkaline. Concretions and masses of calcium carbonate range from none to common.

The C horizon, where encountered, is shale or marl or stratified layers of shale, marl and clay.

COMPETING SERIES: There are no competing series. Similar soils are the Dacosta, Herty, Lufkin, Mabank, and Steedham series. Dacosta soils have a mollic epipedon and are members of the hyperthermic family. Herty, Lufkin and Mabank soils have an abrupt texture change between the A and Bt horizon. In addition, Herty soils are in the udic moisture regime. Steedham soils have sola from 20 to 40 inches thick, and are well drained.

GEOGRAPHIC SETTING: Wilson soils are on nearly level to gently sloping terraces or remnants of terraces. Slope gradients are 0 to 5 percent but dominantly less than 1 percent. The soil formed in alkaline clayey alluvium. Mean annual temperature ranges from 64 to 70 degrees F., and mean annual precipitation ranges from 32 to 45 inches. Frost free days range from 220 to 270 days and elevation ranges from 250 to 700 feet. Thornthwaite P-E indices from 50 to 70.

GEOGRAPHICALLY ASSOCIATED SOILS: These are the Bonham, Burleson, Crockett, Houston Black, Lufkin, Mabank, and Normangee series. Bonham soils have mollic epipedons. Burleson soils are on similar positions. Burleson and Houston Black soils are clayey to the surface and have slickensides (Vertisols). Crockett and Normangee soils have Bt horizons with chroma of more than 2. Bonham, Houston Black, Crockett and Normangee soils are on slightly higher positions above Wilson. Lufkin soils are on similar or slightly lower concave positions. Mabank soils are on similar positions.

DRAINAGE AND PERMEABILITY: Moderately well drained. Permeability is very slow. Runoff is low on 0 to 1 percent slopes, medium on 1 to 3 percent slopes, and high on 3 to 5 percent slopes. Very slow internal drainage. The soil is seasonally wet and is saturated in the surface layer and upper part of the Bt horizon during the winter and spring seasons for periods of 10 to 30 days.

USE AND VEGETATION: Wilson soils are cropped to cotton, sorghums, small grain, and corn. Many areas are now idle or are used for unimproved pasture. Original vegetation was tall prairie grasses, mainly andropogon species, and widely spaced motts of elm and oak trees. Most areas that are not cropped have few to many mesquite trees.

DISTRIBUTION AND EXTENT: Mainly in the Blackland Prairies of Texas, with small areas in Oklahoma. The soil is extensive, probably exceeding 1,000,000 acres.

MLRA OFFICE RESPONSIBLE: Temple, Texas

SERIES ESTABLISHED: Wilson County, Texas; 1907.

REMARKS: Classification change from Udertic Haplustalfs to Oxyaquic Vertic Haplustalfs based on knowledge that these soils are saturated for 2 to 4 weeks in most years. This period of time is within the definition of saturation for one month or more if rules of rounding are applied, i.e., 2 to 6 weeks saturation is considered inclusive.

Diagnostic horizons and features recognized in this pedon are:

Ochric epipedon - 0 to 5 inches. (A horizon; very hard and massive when dry).

Argillic horizon - 5 to 65 inches. (Bt horizons)

Vertic feature - Cracks in the upper part of the argillic horizon (5 to 32 inches), few slickensides between 20 and 77 inches, and linear extensibility greater than 6.0 cm.

ADDITIONAL DATA: Type location pedon NSSL S62TX-(129)257-2 Kaufman County, Texas. Texas Ag. Exp. Station Lab. S63TX-145-1; S82TX-289-32

National Cooperative Soil Survey, U.S.A.

WHITEWRIGHT SERIES

The Whitewright series consists of shallow, well drained, moderately permeable soils that formed in weakly cemented chalk and marl of Upper Cretaceous Age. These gently sloping to moderately steep soils are on convex upland ridges. Slopes are dominantly 4 to 10 percent but range from 1 to 15 percent.

TAXONOMIC CLASS: Loamy, carbonatic, thermic, shallow Typic Haplustepts

TYPICAL PEDON: Whitewright silty clay loam--pasture. (Colors are for dry soil unless otherwise stated.)

A--0 to 5 inches; light brownish gray (10YR 6/2) silty clay loam, grayish brown (10YR 5/2) moist; moderate medium subangular blocky and granular structure; hard, friable; common medium and fine roots; few fine and medium pores; common wormcasts; few fragments of weakly cemented chalk that are 2 mm to 10 mm in size; few strongly cemented fragments of calcite that are 5 to 15 mm across the long axis; calcium carbonate equivalent is about 60 percent; calcareous, moderately alkaline; clear smooth boundary. (6 to 14 inches thick)

Bk--5 to 16 inches; very pale brown (10YR 7/3) silty clay loam, pale brown (10YR 6/3) moist; few medium distinct brownish yellow (10YR 6/6) mottles; moderate fine and medium subangular blocky structure; hard, friable; common fine and medium roots; few fine pores; common wormcasts; about 20 percent by volume of weakly cemented platy fragments of chalk 5 to 20 mm across the long axis; most of the chalk fragments disintegrate upon moistening and gentle rubbing; few fine shell fragments; calcium carbonate equivalent is about 65 percent; few films and threads of calcium carbonate; calcareous, moderately alkaline; abrupt wavy boundary. (6 to 14 inches thick)

Cr--16 to 34 inches; white (10YR 8/1) weakly cemented fractured chalk, interbedded with thin horizontal strata of olive yellow (2.5Y 6/6) silty clay loam; cleavage planes of rock structure are evident in the chalk; the chalk becomes less fractured and more massive below 30 inches depth; few fine roots in the upper part in vertical crevices and between horizontal plates; calcareous, moderately alkaline.

TYPE LOCATION: Grayson County, Texas; from the intersection of Texas Highway 5 and Farm Road 121 in Van Alstyne, Texas, 0.75 mile east on Farm Road 121; 1.25 miles north on an unpaved county road; 100 feet west of road in pasture.

RANGE IN CHARACTERISTICS: Solum thickness ranges from 10 to 20 inches. Silicate clay ranges from 20 to 35 percent in the control section. The soil is calcareous and ranges from 40 to more than 80 percent calcium carbonate equivalent.

The A horizon has colors in hues of 10YR, value 4 to 6, and chroma of 2 to 4. Where the horizon has moist values and chromas of 3 or less, it is less than 7 inches thick. It is silty clay loam or clay loam. Fragments of weakly cemented chalk range from none to about 15 percent by volume. They are platy and range from 2 mm to 3 cm across the long axis. The fragments are weakly to strongly cemented when dry but most of the fragments slake or soften on soaking in water.

The Bw horizon has colors with hue of 10YR, value of 5 to 7, and chroma of 2 to 4. Some pedons have mottles of brown or yellow that are believed to be inherited from the parent material. It is silty clay loam, or clay loam, or their gravelly counterparts. Fragments of weakly to strongly cemented chalk range from a few to 35 percent by volume. However, upon soaking in water, the chalk fragments slake to where the percentage of strongly cemented fragments range from a few to about 20 percent by volume.

The Cr horizon has colors in shades of gray, brown or white. It is weakly cemented platy chalk interbedded with thin strata of light yellowish brown, pale yellow, brownish yellow, or olive yellow clay loam or silty clay loam. The platy fragments of chalk are weakly to strongly cemented but can be readily cut with a spade when moist. In most pedons the chalk becomes less fractured and more massive at 25 to 40 inches depth.

COMPETING SERIES: There are no other series in this family, similar families include the Altoga, Brackett, Cuthand, Dugout, Eddy, Howe, Seawillow, Shiner, Stephen, and Quinlan series. Altoga, Cuthand, Howe, and Seawillow soils have sola more than 20 inches thick. Brackett, Dugout, and Quinlan soils are dry in the moisture control section for longer periods of time. In addition, Brackett soils contain fragments of hard limestone, Dugout soils have a lithic contact to limestone and Quinlan soils have mixed mineralogy and B horizons with redder hues. Eddy soils lack B horizons and have more than 35 percent chalk fragments in the control section. Shiner soils have a mean annual soil temperature of more than 72 degrees F. Stephen soils have mollic epipedons and mixed mineralogy.

GEOGRAPHIC SETTING: Whitewright soils occupy gently sloping to moderately steep uplands. Slopes are mainly 4 to 10 percent but range from 1 to 15 percent. The soil formed in chalk and interbedded marl of the Austin Group of Upper Cretaceous Age. The mean annual temperature is 63 degrees to 66 degrees F. Average annual precipitation ranges from about 35 to 41 inches, and the Thornthwaite P-E index ranges from 56 to 66.

GEOGRAPHICALLY ASSOCIATED SOILS: These include the competing Eddy, Howe, and Stephen series as well as the Austin series. Eddy and Howe soils occupy similar positions. Stephen and Austin soils occupy slightly higher less sloping positions. Stephen and Austin soils have mollic epipedons, and in addition, Austin soils have sola thicker than 20 inches.

DRAINAGE AND PERMEABILITY: Well drained; rapid runoff; moderate permeability.

USE AND VEGETATION: Used mainly for pasture. A few areas are planted to small grain and sorghum. Dominant pasture grasses are King Ranch bluestem, common and improved bermudagrass. Areas that were formerly in cropland are growing silver bluestem, sideoats grama, hairy grama, little bluestem, threeawn, and annual weeds. Woody vegetation is mainly scattered elm, hackberry, and small oak trees.

DISTRIBUTION AND EXTENT: North-central Texas; in the Blackland Prairie Land Resource area. The series is of moderate extent.

MLRA OFFICE RESPONSIBLE: Temple, Texas

SERIES ESTABLISHED: Grayson County, Texas; 1977.

REMARKS: These soils were formerly as a shallow phase of the Austin series and in more recent years they were included in the Brackett series.

Diagnostic horizons and features recognized in this pedon are:

Ochric epipedon - 0 to 5 inches, the A horizon.

Calcic horizon - 5 to 16 inches, the Bk horizon.

Paralithic contact of chalk at a depth of 16 inches.

National Cooperative Soil Survey, U.S.A.

**APPENDIX J: HABITAT EVALUATION PROCEDURE
(HEP) REPORT FOR THE PROPOSED LOWER BOIS
D'ARC CREEK RESERVOIR SITE**

**DRAFT
HABITAT
EVALUATION
PROCEDURE
(HEP) REPORT**

Lower Bois d'Arc
Creek Reservoir

NTD06128

April 2008

Prepared for

North Texas Municipal
Water District

Prepared by

Freese and Nichols, Inc.
4055 International Plaza, Suite 200
Fort Worth, Texas 76109
(817) 735-7300



TABLE OF CONTENTS
HABITAT EVALUATION PROCEDURE

1.0 INTRODUCTION.....1

2.0 APPROACH AND METHODS.....3

 2.1 Study Limits.....3

 2.2 Cover Type Determination and Delineation.....4

 2.3 Evaluation Species Selection and Descriptions.....4

3.0 BASELINE CONDITIONS DETERMINATION11

 3.1 Cover Type Descriptions and Habitat Variable Measurements.....11

 3.2 Baseline Habitat Suitability Indices.....32

 3.3 Baseline Habitat Units33

REFERENCES.....34

TABLES	Page
Table 1. HEP Field Data Summary: Habitat Variable Measurements at Upland Deciduous Forest Sites.....	15
Table 2. HEP Field Data Summary: Habitat Variable Measurements at Evergreen Forest Sites	17
Table 3. HEP Field Data Summary: Habitat Variable Measurements at Tree Savanna Sites	19
Table 4. HEP Field Data Summary: Habitat Variable Measurements at Shrubland Sites	21
Table 5. HEP Field Data Summary: Habitat Variable Measurements at Cropland Sites	23
Table 6. HEP Field Data Summary: Habitat Variable Measurements at Grassland/Old Field Sites.....	25
Table 7. HEP Field Data Summary: Habitat Variable Measurements at Riparian Woodland/Bottomland Hardwood Forest Sites	27
Table 8. HEP Field Data Summary: Habitat Variable Measurements at Shrub Wetland Sites.....	29
Table 9. HEP Field Data Summary: Habitat Variable Measurements at Herbaceous Wetland Sites	31
Table 10. Habitat Suitability Indices by Cover Type.....	32
Table 11. Baseline Habitat Units by Cover Type.	33

APPENDICES

- Appendix A Determination of HSI Values for HEP Analyses
- Appendix B Photographs of Evaluation Sites

FIGURES

Figure 1	HEP Cover Type Mapping.....	12
Figure 2	2007 Aerial Imagery	13

1.0 INTRODUCTION

The Habitat Evaluation Procedure (HEP) is a habitat-based evaluation methodology developed by USFWS in 1974 for use as an analytical tool in impact assessments and project planning. HEP is a species-habitat analysis of the ecological value of a study area; its approach is to quantify the value of habitat available to a selected set of wildlife species within a specified geographic area of interest. The method is designed to describe wildlife habitat values at baseline and future conditions to allow for comparisons of the relative values of different areas at the same point in time or of the same area at different points in time. Because HEP provides a quantitative method for such comparisons, it may be used in planning applications such as the assessment of current and future wildlife habitat, trade-off analyses, or compensation analyses.

HEP appraises a study area by quantifying its Habitat Value, calculated as the product of habitat quantity and habitat quality; this value is expressed in Habitat Units (HU). Habitat quantity is simply the total area of habitat available within the study area, usually expressed in number of acres. If the study area is subdivided into Cover Types (i.e., discrete areas with similar ecological characteristics that are adequately homogeneous), habitat quantities used in evaluation may be subsets of the study area. Habitat quality is expressed in terms of a Habitat Suitability Index (HSI), which is determined by comparing the ecological characteristics of the study area to the habitat characteristics that are optimum for Evaluation Species, representative wildlife species with known habitat requirements selected to provide a basis to assess habitat suitability.

<p>HABITAT VALUE (HU) = Habitat Quantity (Acres) × Habitat Quality (HSI)</p>
--

HSI values are based on two components: the habitat characteristics that provide ideal conditions for an evaluation species, and the habitat characteristics existing in the study area. These characteristics are described by a set of measurable Habitat Variables, such as the height and percent cover of various vegetation types, the distance to water or grain, the availability of perching or nesting sites, or the frequency of flooding. The set of habitat variables needed to determine HSI values are obtained from documented habitat suitability models for each evaluation species. These models describe the species' Life Requisites (i.e., its habitat requirements for food, cover and reproduction), the relationship between the habitat variables' values and the suitability of the area to meet its life

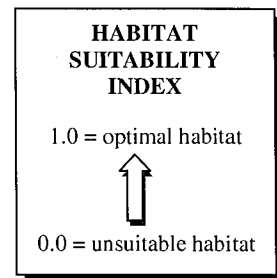

requisites, and the method to integrate these suitability relationships into an HSI value. HSI values range from 0.0 to 1.0, with a ranking of 0.0 being unsuitable and 1.0 being optimum conditions, which are those associated with the highest potential densities of the species. Each increment of change in HSI value must be identical to any other, i.e., HSI must be linearly correlated to carrying capacity.

Habitat values may be calculated for each evaluation species within all its available habitat or for each cover type within the study area. Calculations based on existing ecological conditions can be used to describe baseline conditions and serve as a reference point for resource monitoring or for comparison to predicted future habitat values with or without proposed actions or mitigation measures. HEP provides a consistent means of assessing project impacts by demonstrating, in HUs gained or lost, the beneficial or adverse impacts anticipated as a result of various courses of action. Furthermore, HEP aids mitigation analysis by identifying which factors negatively impact habitat values in various scenarios, e.g., habitat variables resulting in low HSI values, thus suggesting means for improving habitat or selecting mitigation lands.

In summary, the generalized process for conducting a HEP study involves the following components (USFWS 1980):

- Determine the applicability of HEP and define the study area;
- Delineate habitat or vegetation cover types;
- Select the relevant evaluation species;
- Determine each species' life requisites and measure habitat variables for suitability;
- Determine baseline and future habitat units; and
- Develop compensation/mitigation plans for the proposed project.

2.0 APPROACH AND METHODS

The Lower Bois d'Arc Creek Reservoir HEP team included the U.S. Army Corps of Engineers (USACE), the U.S. Environmental Protection Agency (EPA), the U.S. Fish and Wildlife Service (USFWS), the U.S. Forest Service (USFS), Texas Parks and Wildlife Department (TPWD), Texas Water Development Board (TWDB), Texas Commission on Environmental Quality (TCEQ), North Texas Municipal Water District (NTMWD), and Freese and Nichols, Inc. The HEP team had oversight for the tasks that were required for the analysis, including defining the study area, delineating cover types, field sampling, and selecting evaluation species.

LOWER BOIS D'ARC CREEK RESERVOIR HEP TEAM
USACE
EPA
USFS
USFWS
TPWD
TWDB
TCEQ
NTMWD
FNI

The HEP methodology incorporated into this study is recommended by the USFWS as their basic tool for evaluating project impacts and developing mitigation recommendations (USFWS 1993). HEP has been used as a method to evaluate impacts to wildlife habitat for similar projects in Texas. The steps include defining the study limits, describing the baseline conditions in habitat units, and the projection of future habitat conditions. The following describes this method as applied in the present study.

2.1 Study Limits

The process to define the study limits includes the delineation of the study area, determination of cover types, and selection of the evaluation species.

The study area is the geographic area where ecological changes associated with the project are expected to occur and for which evaluation of habitat conditions is conducted. The proposed study area for the Lower Bois d'Arc Creek Reservoir Project is the approximately 17,068-acre area, which includes the area that will be inundated at the normal pool elevation of 534 feet NGVD, and the footprints of the dams, spillways and pump station.

2.2 Cover Type Determination and Delineation

Cover types were delineated using digital color infrared photography flown on January 10, 2007. Nine cover types were identified for HEP analysis within the Lower Bois d'Arc Creek Reservoir project area. The upland cover types included *Upland Deciduous Forest*, *Evergreen Forest*, *Tree Savanna*, *Shrubland*, *Cropland*, and *Grassland / Old Field*. The wetland cover types included *Riparian Woodland / Bottomland Hardwood* (included forested wetland habitat), *Shrub Wetland*, and *Emergent / Herbaceous Wetland*. In addition, the project area included *Shrub Savanna*, *Riverine* and *Lacustrine* cover types that were not used in HEP analysis. Table 1 provides the number of acres in each cover type.

COVER TYPES
Upland Deciduous Forest
Evergreen Forest
Tree Savanna
Shrubland
Cropland
Grassland / Old Field
Riparian Woodland / Bottomland Hardwood
Shrub Wetland
Emergent / Herbaceous Wetland

Table 1. Cover Type Areas.

Cover Type	Area (acres)
Upland Deciduous Forest	2216
Evergreen Forest	228
Tree Savanna	132
Shrubland	63
Cropland	1757
Grassland / Old Field	4761
Riparian Woodland / Bottomland Hardwood	6330
Shrub Wetland	49
Emergent / Herbaceous Wetland	1223

2.3 Evaluation Species Selection and Descriptions

Sixteen evaluation species were selected by the HEP team based on their ecological significance and the availability of applicable HSI models. The species models used in this study were the American kestrel, barred owl, brown thrasher, Carolina chickadee, downy woodpecker, eastern cottontail, eastern meadowlark, eastern turkey, field sparrow, fox squirrel, green heron, raccoon, racer, scissortailed flycatcher, swamp rabbit, and the wood duck.

EVALUATION SPECIES

- American kestrel
- Barred owl
- Brown thrasher
- Carolina chickadee
- Downy woodpecker
- Eastern cottontail
- Eastern meadowlark
- Eastern turkey
- Field sparrow
- Fox squirrel
- Green heron
- Raccoon
- Racer
- Scissortailed flycatcher
- Swamp rabbit
- Wood duck

The following are descriptions of the habitat preferences and life requisites for the study species, along with the cover types that make up their available habitat. Detailed HSI calculations for each species in each cover type, along with any assumptions or exceptions made for the applications of the species models are reported in Appendix A.

American Kestrel (*Falco sparverius*)

The American kestrel is a small, predatory bird associated with open prairies and agricultural lands as well as where these areas border forested habitats. This

raptor hunts insects, birds, small mammals and reptiles in areas of low, open vegetation from adjacent perch sites such as fence posts, trees, and utility lines. Nest sites are found near their hunting habitat, often in mature trees with cavities excavated by other species, as well as in cliffs and on the roofs of old buildings (Author Unknown 1980a).

AMERICAN KESTREL

- COVER TYPES:
 - Tree Savanna
 - Cropland
 - Grassland / Old Field
- LIFE REQUISITES:
 - Open fields with perches
 - Cavities in lone trees or cliffs

Barred Owl (*Strix varia*)

Barred owls are forest-dwelling birds that prefer expansive, mature forests with open sub-canopies allowing for the flying space needed for hunting small game. The species shows no marked preference between upland and bottomland forests. However, since upland forests are

more accessible to logging, forested wetland sites less accessible to timber harvest are currently more likely to provide for their needs. Specifically, barred owl habitat must provide large, decadent trees with adequate numbers of nesting cavities, although nesting has been recorded in abandoned raptor nests. Due to the foliage cover, live trees provide superior nesting sites compared to snags (Allen 1987).

BARRED OWL

- COVER TYPES:
 - Upland Deciduous Forest
 - Riparian Woodland /
 - Bottomland Hardwood
- LIFE REQUISITES:
 - Large, living trees
 - Adequate nesting cavities

Brown Thrasher (*Toxostoma rufum*)

The brown thrasher is a bird species often associated with thickets, hedgerows, midsuccessional forests, and habitats that provide trees in low density and support dense understory growth of shrubs. They primarily forage in the deep leaf litter, using bill sweeps to locate insects and other arthropods, but will also feed in shrubs for seeds and berries. Shrubs are most often used as nest sites, but the presence of evergreen and deciduous trees increases nesting success and provides alternative nest sites (Cade 1986).

BROWN TRASHER
COVER TYPE:
Evergreen Forest

LIFE REQUISITES:
Available but sparse trees
Dense understory & leaf litter

Carolina Chickadee (*Poecile carolinensis*)

Carolina chickadees are residents of forests and forest boundaries, preferring the well-developed canopies and open understories of these habitats, but also utilizing shrub layers. This bird captures moths, caterpillars and other arthropods from the bark and foliage of the trees within these habitats as well as exploiting shrubs for berries and seeds. Carolina chickadees are cavity nesters that utilize natural and excavated sites in tree limbs, snags, and fence posts (Author Unknown 1980b)

CAROLINA CHICKADEE
COVER TYPE:
Upland Deciduous Forest
Evergreen Forest

LIFE REQUISITES:
Forests with deciduous /
evergreen mix
Closed canopies and open
understories
Snags for nesting

Downy Woodpecker (*Picoides pubescens*)

Downy woodpeckers show a preference for open woodlots, but the species is found across North America wherever there are trees that they can drill and glean for the insects they eat. They inhabit both coniferous and deciduous forests. These woodpeckers are not strong excavators, so their nest cavity placement is limited by the availability of soft snags, often with both surface sap rot and fungal heart rot. Living trees with broken crowns are also chosen as nesting sites (Schroeder 1983).

DOWNY WOODPECKER
COVER TYPE:
Upland Deciduous Forest
Riparian Woodland /
Bottomland Hardwood

LIFE REQUISITES:
Open woodlots
Soft snags

Eastern Cottontail (*Sylvilagus floridanus*)

Eastern cottontails are habitat generalists within a wide range of early- to mid-succession

EASTERN COTTONTAIL

COVER TYPE:
 Evergreen Forest
 Tree Savanna
 Shrubland
 Cropland
 Grassland / Old Field

LIFE REQUISITES:
 Fields with shrubby edges
 Dense thickets or hedgerows
 Thick grass or hayfields

habitats. They require an abundance of both well-distributed escape cover and open areas for nocturnal browsing; this combination often consists of old-field bordered by shrubby edge habitat. Eastern cottontails also need dense thickets or hedgerows for resting and daytime shelter. Nests are usually located in areas of thick grass cover, such as hayfields and fallow fields that lie near escape cover (Allen 1984).

Eastern Meadowlark (*Sturnella magna*)

Eastern meadowlarks inhabit grasslands, meadows, pastures, and fallow fields in the south and central United States. While they do need numerous perch sites, such as tall forbs, shrubs, small trees and fences, their preferred habitat consists of relatively open grasslands with low shrub and forb coverage. The eastern meadowlark is a ground-nesting species, so groundcover must be thick for nest concealment (Schroeder and Sousa 1982).

EASTERN MEADOWLARK

COVER TYPE:
 Tree Savanna
 Grassland / Old Field

LIFE REQUISITES:
 Herbaceous or grassy canopy
 Nearby perch sites

Eastern Turkey (*Meleagris gallopavo sylvestris*)

The eastern turkey prefers habitats that provide diverse vegetation regimes, such as riparian or upland forests adjacent to grass or agricultural fields. The diets of these opportunistic

EASTERN TURKEY

COVER TYPE:
 Upland Deciduous Forest
 Evergreen Forest

LIFE REQUISITES:
 Sparse shrub cover
 Nearby mature forests

omnivores are dominated by plant material including fruits, seeds and leaves, but insects and other arthropods are eaten as well. Acorns are particularly important components of the turkey's fall and winter diet. These ground-nesters rely on habitats with dense brush and herbaceous cover for nesting and for raising their young (Schroeder 1985).

Field Sparrow (*Spizella pusilla*)

The field sparrow prefers brushy fencerows and old fields with scattered woody vegetation, and can also be found in grasslands and forested areas. The diet of this ground-foraging species is predominated by vegetative plant material in the spring and summer and by seeds in the fall, but they also forage for insects, especially for the feeding of nestlings. Small trees and shrubby vegetation are used for roosting and winter cover, while a mix of herbaceous vegetation with short, sparse shrubs provides ideal breeding and ground-nesting cover (Sousa 1983).

FIELD SPARROW
 COVER TYPE:
 Shrubland
 LIFE REQUISITES:
 Short, sparse shrubs
 Small trees
 Thick grass cover in Spring

Fox Squirrel (*Sciurus niger*)

While fox squirrels prefer open forest stands with little understory vegetation, they will inhabit a wide variety of forest types. Upland and well-drained bottomland forest habitats are used more often than poorly-drained lowland areas. Small stands of large trees situated in agricultural areas allow fox squirrels to supplement their diet, which consists of mast and a variety of other plant and animal foods, with grains as needed. Mature mast trees provide both food and nesting sites. Fox squirrels will nest in tree cavities, but also build leaf nests; therefore, quality habitat is not limited by the availability of nesting cavities (Allen 1982a).

FOX SQUIRREL
 COVER TYPE:
 Upland Deciduous Forest
 Riparian Woodland /
 Bottomland Hardwood
 LIFE REQUISITES:
 Open forests
 Little understory
 Nearby grain

Green Heron (*Butorides virescens*)

Green herons are predators that wade in or perch above the shallow waters of rivers, lakes, ponds, lagoons, ditches, marshes and swamps, where they hunt for fish, frogs, crawfish and other aquatic animals. They are adaptable generalists within these aquatic environments and inhabit both freshwater and saltwater ecosystems. Their preferred feeding habitat consists of open, permanent, shallow waters that are free of emergent aquatic vegetation. Ideally, adequate cover such as dense stands of reeds and cattails, which also provide nesting areas, are available in proximity to hunting sites. More often, nests are built in shrubs or small trees near the shoreline (Author Unknown 1980c).

GREEN HERON
 COVER TYPE:
 Shrub Wetland
 Herbaceous wetland
 LIFE REQUISITES:
 Shallow, open water
 Nearby shrubs or small trees

Raccoon (*Procyon lotor*)

Costal swamps, marshes and bottomland hardwood forests maintain the greatest numbers of raccoons by supplying their daily need for water and cover. Upland populations are limited by their access to water, preferring hardwood forests near rivers, streams or swamps. Raccoons

RACCOON
COVER TYPE: Riparian Woodland / Bottomland Hardwood Shrub Wetland Herbaceous Wetland
LIFE REQUISITES: Daily access to water Mature forests

forage nocturnally on a limitless variety of food, including fruits, insects, aquatic animals, small mammals and reptiles; access to open areas increases the availability of many of their food sources. These solitary mammals prefer to locate their dens in overmature hardwood trees, especially for raising their young, but will also utilize rock crevices, caves and brush piles (Author Unknown

1980d).

Racer (*Coluber constrictor*)

Racers are snakes that live in grasslands, open woods, and brushy areas. Tall-grass prairie is ideal summer habitat, but pastureland, brushy ravines, hay or grain fields, and open woodlands with adequate cover are widely used by the species. Eggs are often

RACER
COVER TYPE: Shrubland Grassland / Old Field
LIFE REQUISITES: Herbaceous canopy cover Tunnels or other refuge sites

laid in the tunnels of burrowing mammals as well as in rotten logs and stumps. In the fall, racers migrate to rocky outcroppings and ledges with southern exposures where they hibernate in deep crevices (Author Unknown 1980e).

Scissor-tailed Flycatcher (*Tyrannus forficatus*)

Scissor-tailed flycatchers prefer open, tall-grass prairies with small, isolated groups of

SCISSOR-TAILED FLYCATCHER
COVER TYPE: Tree Savanna Cropland Grassland / Old Field
LIFE REQUISITES: Tall, dense herbaceous cover Perch sites in forage habitat Nearby tall trees

deciduous trees. These birds primarily feed on flying and ground-dwelling insects they hunt from perch sites such as tall prairie plants, utility lines, fences or dead tree limbs, although seeds and berries are eaten as well. Isolated groups of trees within herbland savannas or croplands are preferred for nesting sites (Author Unknown 1980f).

Swamp Rabbit (*Sylvilagus aquaticus*)

Swamp rabbits are associated with wetland habitats in the southeastern United States, including bottomland hardwood forests and coastal marshes. In forested settings they prefer open overstory canopies and dense understories that provide for abundant browse. Brush-piles, downfalls, dense herbaceous vegetation such as vine tangles, and even standing, hollow trees provide for swamp rabbit cover. They use tree stumps, logs, and low tree crotches for their resting sites (called forms). The forms must be situated near adequate escape cover (Allen 1985).

SWAMP RABBIT
COVER TYPE:
Shrub Wetland

LIFE REQUISITES:
Open overstory canopies
Dense understories
Fallen trees, stumps, or logs

Wood Duck (*Aix sponsa*)

Year-around residents in the southeastern United States, wood ducks inhabit wooded areas near slow-moving creeks and rivers, as well as those near floodplain lakes, swamps, and beaver ponds. Since wood ducks nest in tree cavities, ideal nesting habitat is mature hardwood forest proximal to aquatic feeding sites. Mast and aquatic vegetation make up the majority of their food-sources. Wood ducks also require adequate loafing sites adjacent to water that have good visibility and proximate cover (Sousa and Farmer 1983).

WOOD DUCK
COVER TYPE:
Riparian Woodland /
Bottomland Hardwood
Shrub Wetland
Herbaceous Wetland

LIFE REQUISITES:
Slow moving waters
Aquatic vegetation
Mature hardwood forest
Protected "loafing" sites

3.0 BASELINE CONDITIONS DETERMINATION

Field sampling was conducted by the HEP team members on June 19-20, July 30, and August 14-17, 2007. HEP site observation and habitat assessment forms completed during this effort are provided in Appendix B. Photographs taken at each site are presented in Appendix C.

The location of sampling sites and the distribution of cover types used in the current study are shown in Figure 1. The distribution of the sampling sites is shown on an aerial photograph of the project site in Figure 2. Field measurements were made within a 0.1-acre quadrant at each site.

3.1 Cover Type Descriptions and Habitat Variable Measurements

The following descriptions of cover types are based on the results of field measurements and observations made during June-August 2007. A table follows each cover type description detailing the results of field measurements for each of the habitat variables needed for calculation of suitability indices (SIs) and HSI values.

Upland Deciduous Forest

Upland forests are defined as non-wetland areas dominated by trees of at least 5 meters in height with a minimum tree canopy closure of 25 percent. In upland deciduous forests, at least 50 percent of that canopy is composed of deciduous species, or those that completely shed their foliage during part of the year (USFWS 1980c). Upland deciduous forests in the project area are composed of 90 percent deciduous trees on average and with an average height of overstory trees of 43 feet. The upland forest cover type makes up approximately 2,216 acres of the proposed Lower Bois d'Arc Creek Reservoir.

UPLAND DECIDUOUS FORESTS

Non-wetland areas dominated by trees and with a minimal tree canopy closure of 25%.

EVALUATION SPECIES:

Barred Owl
 Carolina Chickadee
 Downy Woodpecker
 Eastern Turkey
 Fox Squirrel

Dominant tree species include post oak (*Quercus stellata*), water oak (*Q. nigra*), southern red oak (*Q. falcata*), cedar elm (*Ulmus crassifolia*), sugarberry (*Celtis laevigata*), bois d'arc (*Maclura pomifera*), green ash (*Fraxinus pennsylvanica*) and eastern red cedar (*Juniperus virginiana*). Average tree canopy closure and overstory tree height equal approximately 68 percent and 43 feet, respectively. Deciduous trees comprised 92 percent of the tree canopy on average.

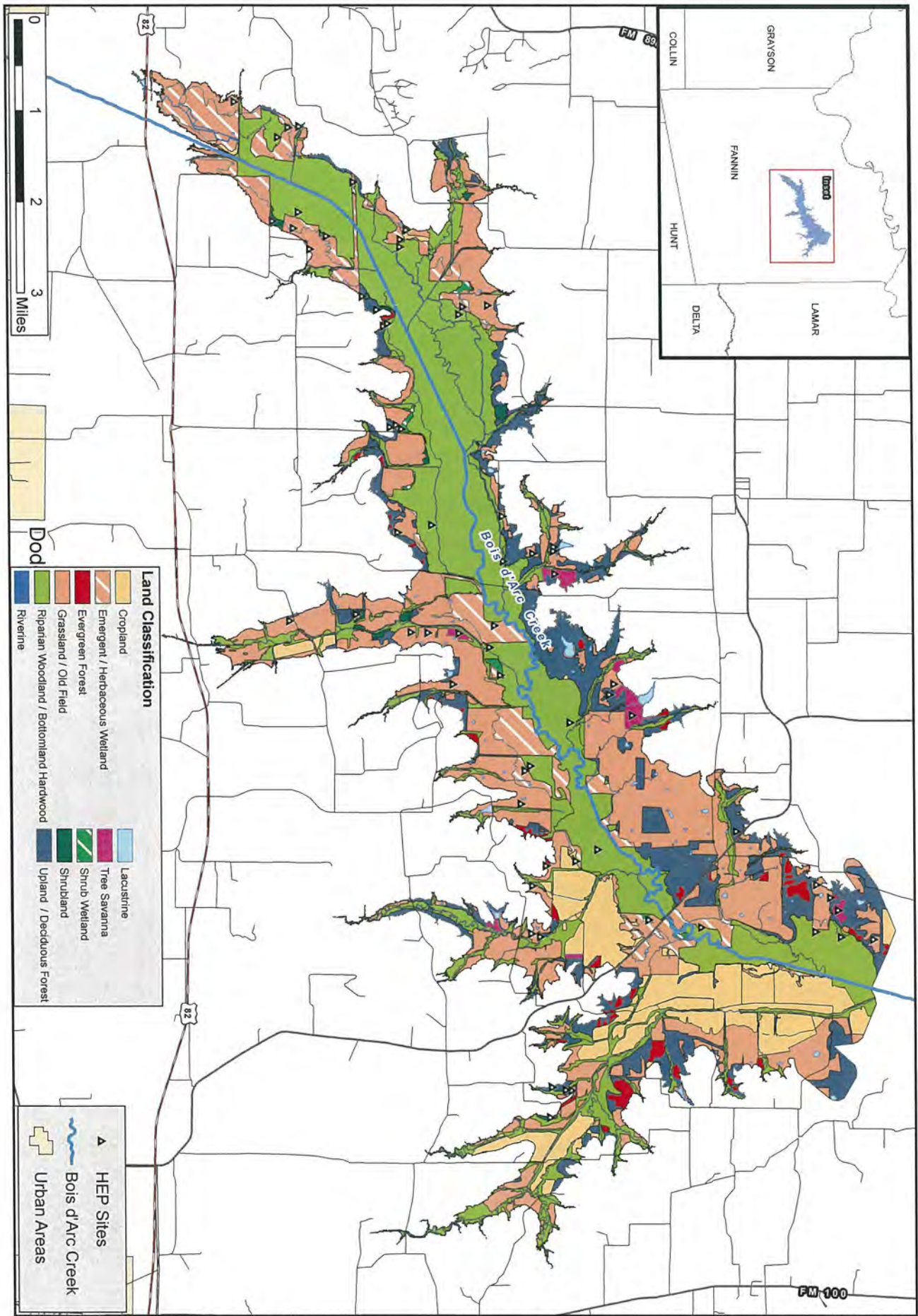

Land Classification

	Cropland		Lacustrine
	Emergent / Herbaceous Wetland		Tree Savanna
	Evergreen Forest		Shrub Wetland
	Grassland / Old Field		Shrubland
	Riparian Woodland / Bottomland Hardwood		Upland / Deciduous Forest
	Riverine		

HEP Sites

Bois d'Arc Creek

Urban Areas

Freese and Nichols
 4055 International Plaza, Suite 200
 Fort Worth, Texas 76109-4895
 817-725-7300



North Texas Municipal Water District
 Proposed Lower Bois d'Arc Creek Reservoir

HEP Cover Type Mapping

FAN JOB NO.	NTD06128
DATE	March 2008
SCALE	1:60,000
DESIGNED	BME
DRAFTED	BME

FILE: Figure1.mxd

FIGURE 1



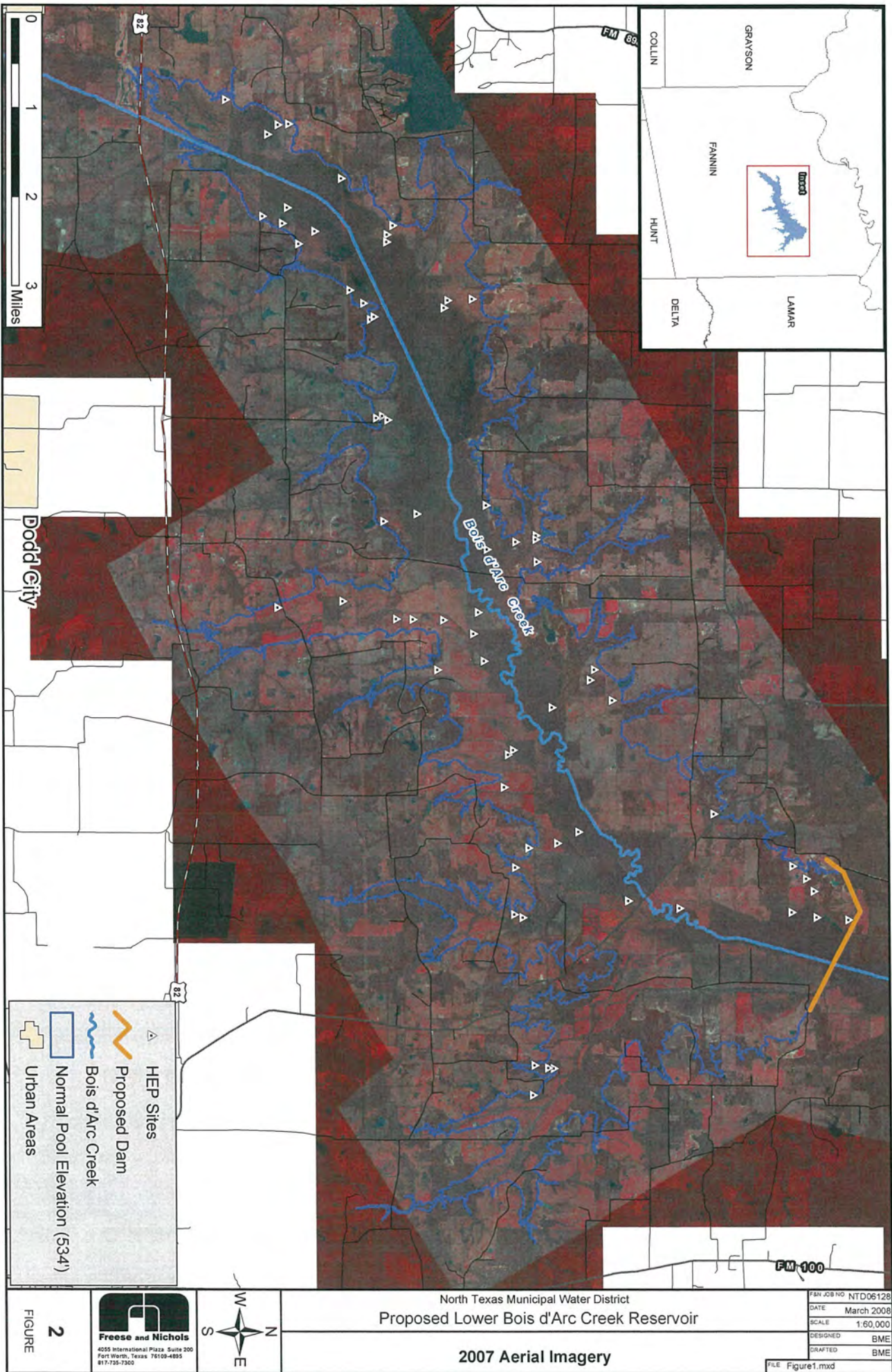

Dodd City

	HEP Sites
	Proposed Dam
	Bois d'Arc Creek
	Normal Pool Elevation (534')
	Urban Areas

Freese and Nichols
 4055 International Plaza Suite 200
 Fort Worth, Texas 76109-4895
 817.755.7300



North Texas Municipal Water District
Proposed Lower Bois d'Arc Creek Reservoir

2007 Aerial Imagery

FSN JOB NO.	NTD06128
DATE	March 2008
SCALE	1:60,000
DESIGNED	BME
DRAFTED	BME

FILE Figure1.mxd

FIGURE 2

Common shrub and vine species include coralberry (*Symphoricarpos orbiculatus*), greenbrier (*Smilax* spp.), honey locust (*Gleditsia triacanthos*), poison ivy (*Toxicodendron radicans*), Virginia creeper (*Parthenocissus quinquefolia*), and dogwood (*Cornus drummondii*). Shrub canopy closure in the typical upland forest averages about 33 percent.

Dominant herbs include sedge (*Carex* spp.), flatsedge (*Cyperus* spp.), panicgrass (*Dichanthelium* spp.), corn salad (*Valerianella* sp.), Virginia wildrye (*Elymus virginicus*), ironweed (*Vernonia* spp.), Venus' looking-glass (*Triodanis* sp.), and wild onion (*Allium ascalonicum*). Average herbaceous canopy cover equals approximately 38 percent. Complete results of HEP field measurements for this cover type are shown in Table 2.

Wildlife observed in this cover type included a variety of bird species such as northern cardinal (*Cardinalis cardinalis*), blue-grey gnatcatcher (*Polioptila caerulea*), downy woodpecker (*Picoides pubescens*), yellow-billed cuckoo (*Coccyzus americanus*), great blue heron (*Ardea herodias*), American crow (*Corvus brachyrhynchos*), brown-headed cowbird (*Molothrus ater*), Carolina chickadee (*Poecile carolinensis*), barred owl (*Strix varia*). Also resident in these areas are various reptiles such as turtles (Order: Testudines), frogs (Order: Anura), snake such as racers (*Coluber constrictor*), and mammals including the eastern fox squirrel (*Sciurus niger*).

**Table 2. HEP Field Data Summary:
Habitat Variable Measurements at Upland Deciduous Forest Sites.**

Cover Type: Upland Deciduous Forest						
Species: Barred Owl, Carolina Chickadee, Downy Woodpecker, Eastern Turkey, Fox Squirrel						
Habitat Variable	Sample Site Number					
	1	2	3	4	5	20
% tree canopy closure	85	50	45	85	95	50
% tree canopy closure of hard mast producers >10" dbh*	0	0	35	10	70	50
% tree canopy closure of soft mast producing trees	60	50	10	90	20	5
% canopy closure deciduous trees in stand	85	25	45	85	80	50
% canopy closure of overstory trees	40	40	35	85	70	50
Average dbh of overstory trees (in)	15	12	18	8	15	16
Average height of overstory trees (ft)	30	35	35	35	60	60
# per acre of snags <10" dbh	200	3	90	10	10	1
# per acre of snags >6" dbh	40	3	0	2	0	1
% shrub crown cover	20	20	15	5	90	45
% herbaceous canopy cover	95	25	15	60	0	30
Average height of herbaceous canopy cover in summer (in)	18	12	12	14	0	6
# per acre of trees >20" dbh	0	0	30	0	0	0
Distance to grain (yd)	660	660	660	660	660	660
Basal Area: area of exposed woody stems if cut horizontally at 4.5 ft height (ft ² /ac)	120	140	60	80	5	160
Average dbh of hard mast producing trees that are >10" dbh (in)	0	0	18	0	40	16
# per hectare of hard mast producing trees >10" dbh	0	0	124	0	99	8
% of shrub crown cover comprised of soft mast producing shrubs	100	5	90	100	15	30
% of forest canopy comprised of evergreens	0	25	0	2	20	0

*dbh: diameter at breast height - the diameter of the stem/trunk measured at a distance of 4.5 feet above the ground.

Evergreen Forest

Evergreen forests also meet the requisites of upland forests, being dominated by trees of at least 5 meters in height with a minimum tree canopy closure of 25 percent. Upland forests in which at least 50 percent of the tree canopy cover is composed of trees that retain their green foliage year-round are designated as evergreen forest (USFWS 1980c). Evergreen forests in the project area have a tree canopy with very few deciduous trees and with little understory. The evergreen forest cover type makes up approximately 228 acres of the proposed Lower Bois d'Arc Creek Reservoir.

<p>EVERGREEN FORESTS</p> <p>Tree canopy closure of 25%. Evergreens make up 50% of canopy.</p> <p>EVALUATION SPECIES: Brown Thrasher Carolina Chickadee Eastern Cottontail Eastern Turkey</p>

These forests are dominated by the evergreen eastern red cedar (*Juniperus virginiana*) mixed with deciduous tree species including red oak (*Quercus falcata*), post oak (*Q. stellata*), and blackjack oak (*Q. marilandica*). Average tree canopy closure equals approximately 70 percent, with evergreens comprising 98 percent of the tree canopy on average.

Shrub and herbaceous cover is sparse in these areas, averaging about 5 and 8 percent, respectively. Shrub and vine species occurring in these forests include coral berry (*Symphoricarpos orbiculatus*), greenbrier (*Smilax* spp.), gum bumelia (*Sideroxylon* (syn. *Bumelia lanuginosum*), and possumhaw holly (*Ilex decidua*). Herbaceous species include Cherokee sedge (*Carex cherokeensis*), panicgrass (*Dichanthelium* sp.), johnsongrass (*Sorghum halepense*), and KR bluestem (*Bothriochloa ischaemum* var. *songarica*). Details of the HEP field measurements for this cover type are shown in Table 3.

Wildlife observed in the evergreen forests of the project area include tufted titmouse (*Baeolophus bicolor*), northern cardinal (*Cardinalis cardinalis*), painted bunting (*Passerina ciris*), Carolina chickadee (*Poecile carolinensis*), pileated woodpecker (*Dryocopus pileatus*), and American crow (*Corvus brachyrhynchos*).

**Table 3. HEP Field Data Summary:
Habitat Variable Measurements at Evergreen Forest Sites**

Cover Type: Evergreen Forest			
Species: Brown Thrasher, Carolina Chickadee, Eastern Cottontail, Eastern Turkey			
Habitat Variable	Sample Site Number		
	1	3	20
% tree canopy closure	80	80	50
# per hectare of hard mast producing trees >10" dbh	1	0	0
% tree canopy closure of soft mast producing trees	80	80	0
Average dbh of overstory trees (in)	6	6	4
% shrub crown cover	5	10	0
% canopy cover of persistent herb vegetation	5	5	5
# per hectare of woody stems >1 m tall	450	1,284	1,729
Average dbh of hard mast producing trees that are >10" dbh (in)	0	0	0
% of shrub crown cover comprised of soft mast producing shrubs	3	100	0
% of forest canopy comprised of evergreens	99	95	100
% ground surface covered by litter >0.4" deep	40	10	20
% canopy closure deciduous trees in stand	5	5	0
Average height of overstory trees (ft)	20	30	30
# per acre snags <10" dbh	20	20	0
% herbaceous canopy cover in summer	10	5	10
Average height of herbaceous canopy in summer (in)	6	6	0

Tree Savanna

In tree savannas, trees taller than 5 meters make up a sparser canopy – between 5 to 25 percent – than in upland forests. Total canopy cover of all vegetation in this cover type is at least 25 percent (USFWS 1980c). Tree savannas in the project site have sparse tree and shrub canopies and abundant herbaceous cover. This cover type makes up about 132 acres of the proposed Lower Bois d'Arc Creek Reservoir.

<p>TREE SAVANNA</p> <p>Tree canopy cover 5-25%. Vegetation canopy cover at least 25%.</p> <p>EVALUATION SPECIES: American Kestrel Eastern Cottontail Eastern Meadowlark Scissor-tailed Flycatcher</p>
--

Tree canopy cover within this cover type averages 12 percent and primarily consists of large lone trees. These trees are most often cedar elms (*Ulmus crassifolia*), bois d'arc (*Maclura pomifera*), or eastern red cedars (*Juniperus virginiana*). Shrub canopy cover is also low in these areas, averaging about 9 percent. The shrub and vine species commonly seen in these areas include gum bumelia (*Sideroxylon* (syn *Bumelia*) *lanuginosum*), coralberry (*Symphoricarpos orbiculatus*), greenbrier (*Smilax* spp.), poison ivy (*Toxicodendron radicans*), and southern dewberry (*Rubus trivialis*).

Herbaceous cover in tree savannas within the project area is both diverse and abundant, averaging 89 percent cover. Species frequently occurring in the herbaceous layer include ironweed (*Vernonia* spp.), western ragweed (*Ambrosia psilostachya*), sedge (*Carex* spp.), flatsedge (*Cyperus* spp.), bermudagrass (*Cynodon dactylon*), panicgrass (*Dichanthelium* spp.), KR bluestem (*Bothriochloa ischaemum* var. *songarica*), indian plantain (*Arnoglossum* spp.), prairie plantain (*Plantago* sp.), croton (*Croton* spp.), and dock (*Rumex* spp.). Complete habitat variable measurements for this cover type are shown in Table 4.

Bird species observed in tree savannas include the Carolina chickadee, yellow-billed cuckoo, painted bunting, white-eyed vireo (*Vireo griseus*), northern cardinal, brown-headed cowbird, and downy woodpecker.

**Table 4. HEP Field Data Summary:
Habitat Variable Measurements at Tree Savanna Sites**

Cover Type: Tree Savanna				
Species: American Kestrel, Eastern Cottontail, Eastern Meadowlark, Scissor-tailed Flycatcher				
Habitat Variable	Sample Site Number			
	1	2	3	4
% herbaceous canopy cover	95	97	75	90
Average height of herbaceous canopy in spring (in)	16	12	12	12
Distance to perch sites: trees, forest edge, fence post, wire, etc (yd)	10	1.7	3.3	0
% herbaceous canopy cover that is grass	50	90	30	80
% shrub canopy cover	1	25	3	5
% tree canopy closure	1	25	15	5
# per acre of deciduous trees	10	150	20	1
Distance to nearest deciduous trees, clumps, forest edge, wing breaks, isolated trees, etc (yd)	10	15	3.3	13.3
% herbaceous canopy <12" tall	80	90	75	90
Availability of large lone trees >12" dbh or groves <1 ac in size containing large trees within 1 mi: A) Abundant: >10 B) Moderate: 4-9 C) Few to None: 0-1	A	A	A	A
Availability of cliff ledges, earth banks, or old abandoned buildings within 1 mi: A) Abundant B) Moderate C) Few to None	C	C	C	B
% canopy cover of persistent herbaceous vegetation (non-woody vegetation that remains after growing season, i.e. over-winter crop)	50	75	30	5

Shrubland

Shrublands are defined as upland areas that are dominated by a shrub layer, which may be composed of shrub species and/or small trees shorter than 5 meters. This covertype should have a shrub canopy cover of at least 25 percent (USFWS 1980c).

Shrublands in the project area represent a midpoint in the successional transition from upland old fields to forests, with a shrub layer dominated by tree species such as green ash (*Fraxinus pennsylvanica*), bois d'arc and eastern red cedar. Shrub species also within this layer include honey locust, persimmon (*Diospyros* sp.), and coralberry. Shrub canopy cover averages approximately 44 percent, while tree canopy cover averages about 3 percent. The diverse herbaceous layer was dominated by cherokee sedge, goldenrod (*Solidago* spp.), johnsongrass, silver bluestem (*Bothriochloa laguroides*), wild pea (*Lathyrus* spp.), and snow on the prairie (*Euphorbia bicolor*). The herbaceous cover is abundant, averaging approximately 89 percent. Complete results of HEP habitat measurements for this cover type are shown in Table 5. There are approximately 63 acres of shrubland within the proposed Lower Bois d'Arc Creek Reservoir.

Shrubland bird species observed in the project area include the northern cardinal, painted bunting, American crow, bluejay (*Cyanocitta cristata*), and white-eyed vireo. The racer snake and garden orbweaver spider (*Argiope aurantia*) was also observed.

<p>SHRUBLAND</p> <p>Dominated by shrubs (including small trees < 5 meters tall)</p> <p>Shrub canopy cover of at least 25 percent</p> <p>EVALUATION SPECIES: Eastern Cottontail Field Sparrow Racer</p>
--

**Table 5. HEP Field Data Summary:
Habitat Variable Measurements at Shrubland Sites**

Cover Type: Shrubland				
Species: Eastern Cottontail, Field Sparrow, Racer				
Habitat Variable	Sample Site Number			
	1	2	3	5
% herbaceous canopy cover	90	100	95	70
% shrub canopy cover	40	75	35	25
# per acre of refuge sites	30	100	10	40
Average height of herbaceous vegetation (in)	15	36	36	8
Distance to shrubby edges or shrub thickets (ft)	20	300	0	20
% of total shrubs that are <4.9' tall	15	50	15	30
% canopy cover of grasses	20	40	75	90
% tree canopy closure	10	0	0	0
% canopy cover of persistent herbaceous vegetation (non-woody vegetation that remains after growing season, i.e. over-winter crop)	75	50	60	50

Cropland

Croplands are defined as agricultural uplands which are planted and harvested annually with agricultural crops; pasture and hayland are excluded from this covertype (USFWS 1980c). The croplands in the project area are primarily planted with oats (*Avena sativa*), soybeans, and hay crops, often alternated with winter wheat (*Triticum aestivum*) cover. Trees and shrubs are excluded from these areas, but are often present in adjacent fencerows. This cover type makes up about 1,757 acres of the proposed Lower Bois d'Arc Creek Reservoir.

<p>CROPLAND</p> <p>Annually planted and harvested uplands.</p> <p>EVALUATION SPECIES:</p> <p>American Kestrel</p> <p>Eastern Cottontail</p> <p>Scissor-tailed Flycatcher</p>

Fallow fields are dominated by johnsongrass (*Sorghum halepense*), but also often include panicgrass, knotroot bristlegrass (*Setaria parviflora*), tall fescue (*Lolium arundinaceum*), and bermudagrass. Forbs are also common in the herbaceous layer, including dock (*Rumex* spp.), pigweed (*Amaranthus* spp.), spurge (*Euphorbia* spp.), morning glory (*Ipomoea* sp.), and black-eyed susan (*Rudbeckia hirta*). This herbaceous cover stands at an average of 22 inches in the spring, with an average canopy cover of approximately 47 percent. Complete results of habitat variable field measurements are shown in Table 6.

Croplands support wildlife populations primarily by providing food sources, and are especially valuable when located adjacent to tree or shrub cover. Bird species observed in the croplands of the project area include the wild turkey (*Meleagris gallopavo*), northern cardinal, painted bunting, white-eyed vireo, tufted titmouse, and blue-gray gnatcatcher.

**Table 6. HEP Field Data Summary:
Habitat Variable Measurements at Cropland Sites**

Cover Type: Cropland			
Species: American Kestrel, Eastern Cottontail, Scissor-tailed Flycatcher			
Habitat Variable	Sample Site Number		
	1	4	20
% herbaceous canopy cover	20	95	25
Average height of herbaceous canopy in spring (in)	18	36	12
Distance to perch sites: trees, forest edge, fence post, wire, etc (yd)	50	109	100
% shrub canopy cover	0	0	0
% tree canopy closure	0	0	0
# per acre of deciduous trees	0	0	0
Distance to nearest deciduous trees, clumps, forest edge, wind breaks, isolated trees, etc (yd)	50	109	100
% canopy cover of persistent herbaceous vegetation (non-woody vegetation that remains after growing season, i.e. over-winter crop)	40	90	10
Availability of large lone trees >12" dbh or groves <1 ac in size containing large trees within 1 mi: A) Abundant: >10 B) Moderate: 4-9 C) Few to None: 0-1	A	A	A
Availability of cliff ledges, earth banks, or old abandoned buildings within 1 mi: A) Abundant: >10 B) Moderate: 4-9 C) Few to None: 0-3	C	C	C
Availability of fence rows, roadside ditches, and grassy-uncultivated areas: A) Abundant B) Moderate C) Scarce to None	A	A	A

Grassland / Old Field

The grassland / old field cover type consists of upland areas with at least a 25 percent canopy cover of predominantly non-woody vegetation in which grasses, whether native or introduced, are dominant. This cover type includes mostly prairies and rangeland (USFWS 1980c). The grassland/old fields in the project area are generally upland improved pastures and are typically the result of forest clearing. These areas may be currently or recently grazed or thickly grown over by grasses and forbs. Grassland in the proposed Lower Bois d'Arc Creek Reservoir covers an area of approximately 4,761 acres.

<p>GRASSLAND</p> <p>Dominated by grasses & non-woody vegetation. Canopy cover of at least 25 percent.</p> <p>EVALUATION SPECIES: American Kestrel Eastern Cottontail Eastern Meadowlark Racer Scissor-tailed Flycatcher</p>
--

Dominant grass species include tall fescue, perennial rye (*Lolium perenne*), bahia grass (*Bahia absinthifolia*), bermudagrass, Texas wintergrass (*Nassella leucotricha*), and dallisgrass (*Paspalum dilatatum*). Common forbs include western ragweed, ironweed), dock, vetch (*Vicia* spp.), and wild pea (*Lathyrus* spp.). Herbaceous canopy cover averages approximately 87 percent, while the herbaceous canopy height in spring averages about 13 inches. Complete results of HEP field measurements for this cover type are shown in Table 7.

Bird species observed in grassland/old field areas include the downy woodpecker, yellow-billed cuckoo, tufted titmouse, Carolina chickadee, northern cardinal, white-eyed vireo, painted bunting, great blue heron, and American crow. Turtle eggs (Order: Testudines) were also observed in this covertime.

**Table 7. HEP Field Data Summary:
Habitat Variable Measurements at Grassland/Old Field Sites**

Cover Type: Grassland / Old Field																
Species: American Kestrel, Eastern Cottontail, Eastern Meadowlark, Racer, Scissor-tailed Flycatcher																
Habitat Variable	Sample Site Number															
	CR 2	CR 3	1	2	3	4	5	6	7	8	11	12	13	14	15	16
% herbaceous canopy cover	75	90	90	90	100	60	95	95	97	98	100	90	30	98	95	90
Average height of herbaceous canopy in spring (in)	12	24	6	12	24	8	12	12	8	8	24	16	12	12	8	16
Distance to perch sites: trees, forest edge, fence post, wire, etc (yd)	29	50	30	25	61	70	58	39	100	13	17	42	50	5.67	76	63
% herbaceous canopy cover that is grass	99	25	88	80	75	5	90	95	98	80	10	40	80	92	95	20
% shrub canopy cover	0	1	0	0	0	0	0	0	0	0	15	0	0	2	0	0
tree canopy closure	0	0	0	0	0	0	0	0	0	0	0	0	0	0	0	0
# per acre of deciduous trees	0	0	0	0	0	0	0	0	0	0	0	0	0	0	0	0
Distance to nearest deciduous trees, clumps, forest edge, wing breaks, isolated trees, etc (yd)	29	130	30	25	61	70	58	64	100	27	17	42	50	40	103	63
Distance to shrubby edge or thickets (ft)	825	537	600	75	100	810	450	321	300	100	50	120	150	273	500	200
# per acre of refuge sites: ground crevice, brush piles, wind throws, etc	0	0	0	10	0	0	0	0	0	0	100	0	10	0	0	0
% herbaceous canopy <12" tall	90	90	90	88	100	0	90	95	97	85	100	85	100	92	95	50
Availability of large lone trees >12" dbh or groves <1 ac in size containing large trees within 1 mi: A) Abundant: >10 B) Moderate: 4-9 C) Few to None: 0-1	A	A	A	A	A	A	A	A	A	A	A	A	A	A	A	A
Availability of cliff ledges, earth banks, or old abandoned buildings within 1 mi: A) Abundant B) Moderate C) Few to None	C	C	C	C	C	C	C	C	C	C	C	C	C	B	C	C
% canopy cover of persistent herbaceous vegetation (non-woody vegetation that remains or growing season, i.e. over-winter crop)	0	90	0	50	100	25	35	75	30	70	75	25	10	40	5	80

Riparian Woodland / Bottomland Hardwood Forest

The riparian woodland / bottomland hardwood cover type includes wetland areas dominated by woody vegetation at least 6 meters tall, with a total vegetation cover of more than 30 percent; this designation is synonymous with the Forested Wetland cover type described in ESM 103 (USFWS 1980c). The riparian woodland / bottomland hardwood cover type in the project area includes the predominantly deciduous forests of riparian zones and wetlands, and is associated with the floodplains of Lower Bois d'Arc Creek and Honey Grove Creek. The condition of the forest floors in these areas varied from standing water to dry, cracking mud. Average tree canopy cover equals approximately 68 percent, while the shrub cover equals approximately 19 percent. There are approximately 6,330 acres of riparian woodland / bottomland hardwood forest in the proposed Lower Bois d'Arc Creek Reservoir pool area.

<p>RIPARIAN WOODLAND / BOTTOMLAND HARDWOOD FOREST</p> <p>Wetland areas dominated by trees. Vegetation cover greater than 30%.</p> <p>EVALUATION SPECIES: Barred Owl Downy Woodpecker Fox Squirrel Raccoon Wood Duck</p>
--

Dominant trees include black willow (*Salix nigra*), boxelder (*Acer negundo*), green ash (*Fraxinus pennsylvanica*), sugarberry (*Celtis laevigata*), and cedar elm (*Ulmus crassifolia*). Average diameter at breast height (dbh) of overstory trees equals approximately 9 inches and basal area in the forest averages 97 square feet per acre. Dominant shrubs are often small trees of the species listed above, as well as honey locust, poison ivy, coralberry, buttonbush (*Cephalanthus occidentalis*), and Virginia creeper. Common herbaceous plants in the bottomland hardwood forest include baccharis (*Baccharis* spp.), cherokee sedge, ragweed (*Ambrosia* spp.), and Virginia wildrye (*Elymus virginicus*). Complete results of HEP field measurements for this cover type are shown in Table 8.

Common avian species observed in the area include the indigo bunting (*Passerina cyanea*), white-eye vireo, yellow-billed cuckoo, American crow, Carolina wren (*Thryothorus ludovicianus*), barred owls, egret (Family: Ardeidae), Carolina chickadee, and northern cardinal. Evidence of mammalian residents included racoon tracks, hog tracks, and beaver chew marks on trees. Reptiles such as the ornate box turtle (*Terrapene ornata*) and unidentified frogs (Order: Anura) were also found in these forests, as were numerous invertebrate species, including crayfish (Family: Cambaridae) and land snails (Class: Gastropoda).

**Table 8. HEP Field Data Summary:
Habitat Variable Measurements at Riparian Woodland/Bottomland Hardwood Forest Sites**

Cover Type: Riparian Woodland															
Species: Barred Owl, Downy Woodpecker, Fox Squirrel, Raccoon, Wood Duck															
Habitat Variable	Sample Site Number														
	1	2	3	4	5	6	7	8	9	11	12	14	15	20	30
% tree canopy closure	60	85	90	50	10	80	95	80	85	50	80	60	70	70	60
% tree canopy closure of hard mast producers >10" dbh	0	0	0	0	0	0	0	0	0	0	0	0	0	0	0
Average dbh of overstory trees (in)	8	8	8	9	8	4	5	8	8	15	10	8	12	20	5
Overstory forest size class A) <6" dbh B) 6-10" dbh C) 10-20" dbh D) >20" dbh	B	B	B	B	B	A	A	B	B	C	B	B	C	C	A
# per acre of snags >6" dbh	40	120	20	20	30	0	10	0	10	30	1	0	40	30	0
% shrub crown cover	10	5	5	5	80	5	10	20	10	60	10	10	10	25	15
# per acre of refuge sites	10	10	70	3	60	20	120	30	100	20	20	0	20	40	0
Distance to water (yd)	0	467	17	40	3	100	67	100	133	0	100	567	33	3	200
Water regime: A) Permanent B) Semi-permanent: 3 mo Apr-Sept C) Semi-permanent: 3-5 mo Apr-Sept D) None or Ephemeral	B	B	B	B	B	B	B	B	A	C	B	B	B	B	B
# per acre of potential nest cavities	0	0	0	1	0	0	30	20	0	40	10	0	0	20	0
% water area covered by logs, trees limbs, shrub cover or herbaceous vegetation (live or dead & overhanging within 1 m of surface) in summer	15	0	5	0	10	15	5	25	5	80	10	5	5	5	10
% water surface covered by logs, tree or shrub overhangs, etc in winter (persistent)	8	0	3	0	10	15	5	15	5	65	8	5	5	5	10
# per acre of trees >20" dbh	0	10	0	10	0	0	0	10	0	20	0	0	0	0	0
Basal Area: area of exposed woody stems if cut horizontally at 4.5 ft height (ft ² /ac)	120	170	180	120	10	80	50	90	2	150	60	150	150	20	110
Distance to grain (yd)	660	660	660	660	660	660	660	660	660	660	660	660	660	660	660
% canopy closure of overstory trees	50	60	60	20	10	75	80	80	40	40	75	55	40	30	60

Shrub Wetland

Shrub (or shrub-scrub) wetlands are defined as areas dominated by woody vegetation that is less than 5 meters tall, with greater than 30 percent total vegetation cover. Shrub-dominated riparian zones are included in this cover type (USFWS 1980c). Shrub wetlands in the study area can be considered wetlands in successional transition between herbaceous wetlands and bottomland hardwood forests. Approximately 49 acres of the proposed Lower Bois d'Arc Creek Reservoir consist of the shrub wetland cover type.

<p>SHRUB WETLAND</p> <p>Vegetation dominated by shrubs; includes shrub-dominated riparian zones</p> <p>EVALUATION SPECIES: Green Heron Raccoon Swamp Rabbit Wood Duck</p>
--

The shrub layer is dominated by small trees such as green ash (*Fraxinus pennsylvanica*), sugarberry (*Celtis laevigata*), and cedar elm (*Ulmus crassifolia*), as well as shrub species such as honey locust (*Gleditsia triacanthos*) and baccharis (*Baccharis* spp.). Shrub canopy cover averages approximately 48 percent. Dominant herbaceous plants include sedge (*Carex* spp.), ragweed (*Ambrosia* spp.), ironweed (*Vernonia* spp.), goldenrod (*Solidago* spp.), evening primrose (*Oenothera speciosa*), round-leaf groundsel (*Packera obouta*), trumpet vine (*Campsis radicans*), and wild pea (*Lathyrus* spp.). Herbaceous canopy cover averages about 66 percent. Complete results of HEP field measurements for this cover type are shown in Table 9.

Birds observed in the shrub wetlands of the project area included northern cardinal, painted bunting, American crow, great egret (*Ardea alba*), solitary warbler (Family: Parulidae), common yellow throat (*Geothlypis trichas*). Evidence of mammalian residents includes tracks of the raccoon and bite marks of beaver (*Castor canadensis*). The southern leopard frog (*Rana sphenoccephala*) and crayfish (Family: Cambaridae) were also observed in the shrub wetlands.

**Table 9. HEP Field Data Summary:
Habitat Variable Measurements at Shrub Wetland Sites**

Cover Type: Shrub Wetland					
Species: Green Heron, Raccoon, Swamp Rabbit, Wood Duck					
Habitat Variable	Sample Site Number				
	1	2	3	4	5
Distance to water (yd)	567	3	0	200	50
Water regime: A) Permanent water B) Semi-permanent water C) None or ephemeral flooding	B	B	B	A	B
Water Regime: 1) Permanent 2) Intermittently exposed 3) Semi-permanent 4) Seasonally flooded 5) None or ephemeral	4	3	3	4	3
Water Current: A) Still or Slow B) Moderately slow C) Moderately fast D) Fast	A	A	A	A	A
# per acre of refuge sites	0	0	30	0	50
% water area <10" deep in average summer conditions	100	100	100	100	100
% emergent herbaceous cover in littoral zone	25	60	100	60	0
% water area covered by logs, trees limbs, shrub cover or herbaceous vegetation (live or dead & overhanging within 1 m of surface) in summer	25	0	95	50	40
% water surface covered by logs, tree or shrub overhangs, etc in winter (persistent)	25	0	60	25	40
Aquatic substrate composition: A) Muddy B) Sandy C) Rocky	A	A	A	A	A
# per acre of potential nest cavities	0	0	0	0	0
% shrub crown closure	65	60	45	90	40
% herbaceous canopy cover	10	67	100	60	100

Emergent / Herbaceous Wetland

Herbaceous wetlands are defined as wetland areas with a total vegetation cover of greater than 30 percent that is dominated by hydrophytic plants growing on or below the water surface (USFWS 1980c). The “emergent wetlands” of Cowardin et al. (1979) are included in this cover type. There are approximately 1,223 acres of herbaceous wetland within the proposed Lower Bois d'Arc Creek Reservoir site.

**EMERGENT /
HERBACEOUS
WETLAND**

Vegetative cover >30%
dominated by hydrophytic
plants.

EVALUATION SPECIES:

Green Heron
Raccoon
Wood Duck

Emergent wetlands in the project area are dominated by an herbaceous layer made up of wetland obligates such as rushes, sedges, smartweed, and redstem (*Ammannia* sp.). The shrub layer is primarily made up of black willow, green ash, baccharis, swampprivet (*Forestiera* sp.), buttonbush, honeylocust, cocklebur (*Xanthium strumarium*), and desert false indigo (*Amorpha fruticosa*). The herbaceous canopy includes numerous grass species, such as barnyard grass (*Echinochloa crus-galli*), crowngrass (*Paspalum* sp.), and eastern gammagrass (*Tripsacum dactyloides*). Other plants found in the herbaceous wetlands include rushes (*Juncus* spp.), blue sedge (*Carex glaucoidea*), spikerush (*Eleocharis* spp.), flatsedge (*Cyperus* spp.), smartweed (*Polygonum* spp.), sumpweed (*Iva annua*), frog fruit (*Phyla* spp.), water primrose (*Ludwigia* sp.), balloon vine (*Cardiospermum halicacabum*), dock (*Rumex* spp.), and buttercup (*Ranunculus* spp.). Complete results of HEP field measurements for this cover type are shown in Table 10.

Many species of birds were found in the herbaceous wetlands, including the northern cardinal, American crow, indigo bunting, tufted titmouse, great blue heron, great egret, red-tailed hawk (*Buteo jamaicensis*), and northern harrier (*Circus cyaneus*). Other wildlife resident in the areas include several mammals, such as raccoon (*Procyon lotor*), beaver (*Castor canadensis*), feral hog (*Sus scrofa*), and white-tailed deer (*Odocoileus virginianus*); aquatic species including frogs (Order: Anura), mosquitofish (*Gambusia affinis*), crayfish (Family: Cambaridae), and clams (Class: Bivalvia); and plentiful flying insects such as butterflies (Order: Lepidoptera), bees (Order: Hymenoptera) and dragonflies (Order: Odonata).

**Table 10. HEP Field Data Summary:
Habitat Variable Measurements at Herbaceous Wetland Sites**

Cover Type: Emergent Wetlands						
Species: Green Heron, Raccoon, Wood Duck						
Habitat Variable	Sample Site Number					
	1	2	3	4	5	6
Distance to water (yd)	0	0	10	0	0	0
Water regime: A) Permanent water B) Semi-permanent water C) None or ephemeral flooding	B	B	B	C	B	A
Water Current: A) Still or Slow: <6" per sec B) Moderately slow: 6-24" per sec C) Moderately fast: 24-40" per sec D) Fast: >40" per sec	A	A	A	A	A	A
# per acre of refuge sites	0	0	0	20	50	0
% water area <10" deep in average summer conditions	100	100	100	100	25	15
% emergent herbaceous cover in littoral zone	75	90	50	95	50	20
% water area covered by logs, trees limbs, shrub cover or herbaceous vegetation (live or dead & overhanging within 1 m of surface) in summer	75	90	0	2	15	5
% water surface covered by logs, tree or shrub overhangs, etc in winter (persistent)	20	75	0	2	15	5
Aquatic substrate composition: A) Muddy B) Sandy C) Rocky	A	A	A	A	A	A
Distance to forested/shrub wetland, i.e. large trees (yd)	80	214	47	75	40	17
# per acre of potential nest cavities	0	0	0	10	0	0

3.2 Baseline Habitat Suitability Indices

After species selection, cover types were sampled for the appropriate habitat variables required for each species' HSI model. The sampling site locations illustrated relative to cover types is shown in Figure 1, and on color IR aerial imagery in Figure 2.

Calculation of HSI values were performed according to standard models developed for each evaluation species. Exceptions and assumptions for each species model and the specific HSI calculations for each species evaluated by cover type are described in Appendix A. To compute the HSI for a cover type, site measurements for each variable were averaged for each cover type and then were used in the HSI model for each species. The HSI for each cover type was calculated as the arithmetic mean of all the individual species' HSIs (Table 11).

Table 11. Habitat Suitability Indices by Cover Type

Species	Cover Types								
	Upland Deciduous Forest	Evergreen Forest	Tree Savanna	Shrubland	Cropland	Grassland / Old Field	Riparian Woodland / Bottomland Hardwood	Shrub Wetland	Emergent / Herbaceous Wetland
American kestrel	--	--	1.00	--	1.00	1.00	--	--	--
Barred owl	0.20	--	--	--	--	--	0.14	--	--
Brown thrasher	--	0.02	--	--	--	--	--	--	--
Carolina chickadee	0.75	0.40	--	--	--	--	--	--	--
Downy wood-pecker	0.29	--	--	--	--	--	0.34	--	--
Eastern cottontail	--	0.31	0.31	0.31	0.31	0.31	--	--	--
Eastern meadowlark	--	--	0.59	--	--	0.53	--	--	--
Eastern turkey	0.68	0.68	--	--	--	--	--	--	--
Field sparrow	--	--	--	0.43	--	--	--	--	--
Fox squirrel	0.42	--	--	--	--	--	0.03	--	--
Green heron	--	--	--	--	--	--	--	0.81	0.87
Raccoon	--	--	--	--	--	--	0.52	0.28	0.17
Racer	--	--	--	0.98	--	0.18	--	--	--
Scissor-tailed flycatcher	--	--	1.00	--	0.83	0.98	--	--	--
Swamp rabbit	--	--	--	--	--	--	--	0.52	--
Wood duck	--	--	--	--	--	--	0.22	0.22	0.22
Average HSI Values	0.47	0.35	0.73	0.57	0.72	0.60	0.25	0.46	0.42

3.3 Baseline Habitat Units

Baseline Habitat Units (HUs) were calculated for each cover type within the Lower Bois d'Arc Creek Reservoir project area by multiplying the average cover type Habitat Suitability Index (HSI) values (Table 10) by the cover type acreage (Table 12).

Table 12. Baseline Habitat Units by Cover Type.

Cover Type	Average HSI Values	Area (acres)	Habitat Units (HUs)
Upland Deciduous Forest	0.47	2,216	1,042
Evergreen Forest	0.35	228	80
Tree Savanna	0.73	132	96
Shrubland	0.57	63	36
Cropland	0.72	1,757	1,265
Grassland / Old Field	0.60	4,761	2,857
Riparian Woodland / Bottomland Hardwood	0.25	6,330	1,583
Shrub Wetland	0.46	49	23
Emergent / Herbaceous Wetland	0.42	1,223	514
TOTAL HABITAT UNITS			7,494

REFERENCES

- Allen, A. W. 1982a. Habitat Suitability Index Models: Fox Squirrel. U.S. Department of Interior, Fish and Wildlife Service. FWS/OBS-82/10.18. 11p.
- Allen, A. W. 1984. Habitat Suitability Index Models: Eastern Cottontail. U.S. Department of Interior, Fish and Wildlife Service. FWS/OBS-82/10.66. 23 pp.
- Allen, A. W. 1985. Habitat Suitability Index Models: Swamp Rabbit. U.S. Department of Interior, Fish and Wildlife Service. FWS/OBS-82/107. 20p.
- Allen, A.W. 1987. Habitat Suitability Models: Barred Owl. U.S. Department of Interior, Fish and Wildlife Service. FWS/OBS-82/10.143. 17 pp.
- Author Unknown. 1980a. Habitat Suitability Index Models: American Kestrel (Review Copy; p. 174-184). U.S. Department of Interior, Fish and Wildlife Service. 11 pp.
- Author Unknown. 1980b. Habitat Suitability Index Models: Carolina Chickadee (Review Copy; p.233-239). U.S. Department of Interior, Fish and Wildlife Service. 7 pp.
- Author Unknown. 1980c. Habitat Suitability Index Models: Green Heron (Review Copy; p.138-146). U.S. Department of Interior, Fish and Wildlife Service. 9 pp.
- Author Unknown. 1980d. Habitat Suitability Index Models: Raccoon (Review Copy; p.99-108). U.S. Department of Interior, Fish and Wildlife Service. 10 pp.
- Author Unknown. 1980e. Habitat Suitability Index Models: Racer (Review Copy; p.259-264). U.S. Department of Interior, Fish and Wildlife Service. 6 pp.
- Author Unknown. 1980f. Habitat Suitability Index Models: Scissor-tailed Flycatcher (Review Copy; p.227-232). U.S. Department of Interior, Fish and Wildlife Service. 6 pp.
- Cade, B. S. 1986. Habitat Suitability Index Models: Brown Thrasher. U.S. Department of Interior, Fish and Wildlife Service. FWS/OBS-82/10.118. 14 pp.
- Cowardin, L.M., F.C. Golet and E.T. LaRoe. 1979. Classification of Wetlands and Deepwater Habitats of the United States. U.S. Fish and Wildlife Service, Washington, D.C. FWS/OBS-79/31. *Cited In:* USFWS 1980c.
- Natural Resources Conservation Service (NRCS). 2007. The PLANTS Database (Online). Available URL: <http://plants.usda.gov> [Accessed 7 December 2007]. U.S. Department of Agriculture, National Plant Data Center, Baton Rouge, LA.
- Schroeder, R. L. 1983. Habitat Suitability Index Models: Downy Woodpecker. U.S. Department of Interior, Fish and Wildlife Service. FWS/OBS-82/10.38. 10 pp.
- Schroeder, R. L. 1985. Habitat Suitability Index Models: Eastern Turkey. U.S. Department of Interior, Fish and Wildlife Service. FWS/OBS-82/10.106. 33 pp.
- Schroeder, R. L., and P. J. Sousa. 1982. Habitat Suitability Index Models: Eastern Meadowlark. U.S. Department of Interior, Fish and Wildlife Service. FWS/OBS-82/10.29. 9 pp.
- Sousa, P. J. 1983. Habitat Suitability Index Models: Field Sparrow. U.S. Department of Interior, Fish and Wildlife Service. FWS/OBS-82/10.62. 14 pp.

- Sousa, P. J., and A. H. Farmer. 1983. *Habitat Suitability Index Models: Wood Duck*. U.S. Department of Interior, Fish and Wildlife Service. FWS/OBS-82/10.43. 27 pp.
- U.S. Fish and Wildlife Service (USFWS). 1980a. *Habitat as a Basis for Environmental Assessment*. Ecological Services Manual (ESM) 101. Division of Ecological Services, U.S. Fish and Wildlife Service, Department of the Interior. Washington, D.C.
- U.S. Fish and Wildlife Service (USFWS). 1980b. *Habitat Evaluation Procedures (HEP)*. Ecological Services Manual (ESM) 102. Division of Ecological Services, U.S. Fish and Wildlife Service, Department of the Interior. Washington, D.C.
- U.S. Fish and Wildlife Service (USFWS). 1980c. *Standards for the Development of Habitat Suitability Index Models*. Ecological Services Manual (ESM) 103. Division of Ecological Services, U.S. Fish and Wildlife Service, Department of the Interior. Washington, D.C.
- U.S. Geological Society. USGS, NBII. 2007. *The Integrated Taxonomic Information System (ITIS) Database* (Online <http://www.itis.gov>). Accessed 26 December 2007. USGS Biological Informatics Office, Reston, VA.

Appendix A

Determination of HSI Values for HEP Analyses

Table A-1. HSI Calculation: Upland Deciduous Forest Cover Type

Cover Type: Upland Deciduous Forest									
Species: Barred Owl, Carolina Chickadee, Downy Woodpecker, Eastern Turkey, Fox Squirrel									
Variable		Area / Site Number							
		1	2	3	4	5	20		
Barred Owl									
Variable name	#	Value	Value	Value	Value	Value	Value		
Number of trees >20" dbh/acre	V1	0	0	30	0	0	0		
Average dbh of overstory trees (in)	V2	15	12	18	8	15	16		
Percent canopy cover of overstory trees	V3	40	40	35	85	70	50		
		SI	SI	SI	SI	SI	SI		
	SI1	0.1	0.1	1.0	0.1	0.1	0.1		
	SI2	0.7	0.5	0.9	0.2	0.7	0.7		
	SI3	0.5	0.5	0.4	1.0	1.0	0.8	Average	
HSI = Reproductive Suitability Index $= (SI1 \times SI2)^{1/2} \times SI3$		HSI =	0.13	0.11	0.35	0.14	0.26	0.20	0.20
Carolina Chickadee									
Variable name	#	Value	Value	Value	Value	Value	Value		
Average height of overstory trees (m)	V1	9.1	10.7	10.7	10.7	18.3	18.3		
Percent tree canopy closure	V2	85	50	45	85	95	50		
Percent canopy closure of deciduous trees in stand	V3	85	25	45	85	80	50		
Number of snags < 25 cm (10 in) dbh per 0.4 ha (1 acre)	V4	200	3	90	10	10	1		
		SI	SI	SI	SI	SI	SI		
	SI1	0.6	0.7	0.7	0.7	1.0	1.0		
	SI2	1.0	0.7	0.6	1.0	1.0	0.7		
	SI3	0.8	0.9	1.0	0.8	0.9	1.0		
Reproduction Value	SI4	1.0	1.0	1.0	1.0	1.0	0.4		
Cover Value = (SI1 × SI2 × SI3)^{1/3}			0.8	0.8	0.7	0.8	1.0	0.9	Average
Lowest Life Requisite Value		HSI=	0.78	0.77	0.75	0.84	0.95	0.43	0.75
Downy woodpecker									
Variable name	#	Value	Value	Value	Value	Value	Value		
Basal area (ft ² per acre)	V1	120	140	60	80	5	160		
Number of snags >6 in dbh/acre	V2	40	3	0	2	0	1		
		SI	SI	SI	SI	SI	SI		
Food Value	SI1	0.6	0.5	1.0	1.0	0.1	0.5		
Reproduction Value	SI2	1.0	0.6	0.0	0.4	0.0	0.2	Average	
Lowest Life Requisite Value		HSI=	0.62	0.50	0.00	0.40	0.00	0.20	0.29

(Table A-1. HSI Calculation: Upland Deciduous Forest Cover Type, Continued)

Cover Type: Upland Deciduous Forest								
Species: Barred Owl, Carolina Chickadee, Downy Woodpecker, Eastern Turkey, Fox Squirrel								
Variable		Area / Site Number						
		1	2	3	4	5	20	
Eastern Wild Turkey								
Variable name	#	Value	Value	Value	Value	Value	Value	
Percent herbaceous canopy cover	V1	95	25	15	60	0	30	
Average height of herbaceous canopy in summer (cm)	V2	45.7	30.5	30.5	35.6	0	15.2	
Average dbh of hard mast producing trees ≥25.4 cm (cm)	V4a	0	0	45.7	0	101.6	40.6	
Number of hard mast producing trees/ha that are ≥25.4 cm (# / ha)	V4b	0	0	123.5	0	99	8	
Percent canopy closure of soft mast producing trees	V5	60	50	10	90	20	5	
Percent shrub crown cover	V6 & V7	20	20	15	5	90	45	
Percent shrub crown cover comprised of soft mast producing shrubs	V8	100	5	90	100	15	30	
Percent tree canopy closure	V11	85	50	45	85	95	50	
Average dbh of overstory trees (in)	V12	15	12	18	8	15	16	
Percent of forest canopy comprised of evergreens	V13	0	25	0	2	20	0	
<i>Deciduous Forest Model</i>		SI	SI	SI	SI	SI	SI	
	SI1	0.6	0.1	0.0	1.0	0.0	0.3	
	SI2	1.0	1.0	1.0	1.0	0.0	0.7	
	SI4	0.0	0.0	1.0	0.0	0.8	0.1	
	SI5	1.0	1.0	0.3	1.0	0.5	0.1	
	SI6	1.0	1.0	0.8	0.3	1.0	1.0	
	SI7	1.0	1.0	1.0	1.0	0.0	0.9	
	SI8	1.0	0.4	0.9	1.0	0.5	0.6	
	SI11	1.0	1.0	0.9	1.0	1.0	1.0	
	SI12	1.0	1.0	1.0	0.5	1.0	1.0	
	SI13	1.0	1.0	1.0	1.0	1.0	1.0	
							Average	
	Summer Food/Brood Value = $(SI1 \times SI2)^{1/2}$	0.8	0.4	0.0	1.0	0.0	0.4	0.43
	Fall/Winter/Spring Food Value = $([(SI4 + SI5) + (SI6 \times SI8)] \div 2) \times SI7$	1.0	0.7	0.9	0.6	0.0	0.3	0.59
	Cover Value = $SI11 \times SI12 \times SI13$	1.0	1.0	0.9	0.5	1.0	1.0	0.89
	<i>See Eastern Wild Turkey Multi-cover Type Worksheet</i>	HSI=						0.68
Fox Squirrel								
Variable name	#	Value	Value	Value	Value	Value	Value	
Percent canopy closure of trees that produce hard mast >10 in dbh	V1	0	0	35	10	70	50	
Distance to available grain (yd)	V2	660	660	660	660	660	660	
Average dbh of overstory trees (in)	V3	15	12	18	8	15	16	
Percent tree (>16.5 ft height) canopy closure	V4	85	50	45	85	95	50	
Percent shrub (<16.5 ft height) crown cover	V5	20	20	15	5	90	45	
		SI	SI	SI	SI	SI	SI	
	SI1	0.0	0.0	0.9	0.3	0.9	1.0	
	SI2	0.1	0.1	0.1	0.1	0.1	0.1	
	SI3	1.0	0.6	1.0	0.1	1.0	1.0	
	SI4	0.7	1.0	1.0	0.7	0.6	1.0	
	SI5	1.0	1.0	1.0	1.0	0.1	0.7	
	Winter Food Value = $(3 \times SI1 + SI2) \div 3$	0.0	0.0	0.9	0.3	0.9	1.0	
	Cover/Reproduction Value = $(SI3 \times SI4 \times SI5)^{1/3}$	0.9	0.8	1.0	0.4	0.4	0.9	
							Average	
	<i>Lowest Life Requisite Value</i>	HSI=						0.42

Table A-2. HSI Calculation: Evergreen Forest Cover Type					
Cover Type: Evergreen Forest					
Species: Brown Thrasher, Carolina Chickadee, Eastern Cottontail, Eastern Turkey					
Variable	Area / Site Number				
	1	3	20		
Brown Thrasher					
Variable name	#	Value	Value	Value	
Density of wood stems ≥ 1.0m (3.3 ft) tall (1000s/ha)	V1	0.5	1.3	1.7	
Percent canopy cover of trees	V2	80	80	50	
Percent of ground surface covered by litter ≥ 1 cm (0.4 in) deep	V3	40	10	20	
		SI	SI	SI	
	SI1	0.1	0.2	0.3	
	SI2	0.4	0.4	0.7	
	SI3	0.4	0.1	0.1	Average
HSI = Food/Cover/Reproduction Value = SI1 × SI2 × SI3	HSI=	0.02	0.01	0.02	0.02
Carolina Chickadee					
Variable name	#	Value	Value	Value	
Average height of overstory trees (m)	V1	6.1	9.1	9.1	
Percent tree canopy closure	V2	80	80	50	
Percent canopy closure of deciduous trees in stand	V3	5	5	0	
Number of snags < 25 cm (10 in) dbh per 0.4 ha (1 acre)	V4	20	20	0	
		SI	SI	SI	
	SI1	0.2	0.6	0.6	
	SI2	1.0	1.0	0.7	
	SI3	0.7	0.7	0.6	
Reproduction Value	SI4	1.0	1.0	0.0	
Cover Value = (SI1 × SI2 × SI3)^{1/3}		0.5	0.7	0.6	Average
Lowest Life Requisite Value	HSI =	0.47	0.73	0.00	0.40
Eastern Cottontail					
Variable name	#	Value	Value	Value	
Percent shrub (<16.5 ft height) crown cover	V1	5	10	0	
Percent tree (>16.5 ft height) canopy closure	V2	80	80	50	
Percent canopy closure of persistent herbaceous vegetation	V3	5	5	5	
		SI	SI	SI	
	SI1	0.3	0.5	0.0	
	SI2	0.5	0.5	1.0	
	SI3	0.0	0.0	0.0	Average
Winter Cover / Food Index = WCFI = ((4 × SI1 + SI2) ÷ 5) + SI3		0.3	0.5	0.2	0.37
<i>See Eastern Cottontail Multi-cover Type Worksheet</i>	HSI =				0.31
Eastern Wild Turkey					
Variable name	#	Value	Value	Value	
Average dbh of hard mast producing trees ≥25.4 cm (cm)	V4a	0	0	0	
Number of hard mast producing trees per hectare ≥25.4 cm dbh (# / ha)	V4b	1	0	0	
Percent canopy closure of soft mast producing trees	V5	80	80	0	
Percent shrub crown cover	V6 & V7	5	10	0	
Percent shrub crown cover of soft mast producing shrubs	V8	3	100	0	
Percent tree canopy closure	V11	80	80	50	
Average dbh of overstory trees (in)	V12	6	6	4	
Percent of forest canopy comprised of evergreens	V13	99	95	100	
		SI	SI	SI	
	SI4	0.0	0.0	0.0	
	SI5	1.0	1.0	0.0	
	SI6	0.3	0.5	0.0	
	SI7	1.0	1.0	1.0	
	SI8	0.4	1.0	0.4	
	SI11	1.0	1.0	1.0	
	SI12	0.2	0.2	0.1	
	SI13	0.2	0.3	0.2	Average
Fall/Winter/Spring Food Value = ((SI4 + SI5) + (SI6 × SI8)) ÷ 2)		0.6	0.8	0.0	0.43
Cover Value = SI11 × SI12 × SI13		0.0	0.1	0.0	0.04
<i>See Eastern Wild Turkey Multi-cover Type Worksheet</i>	HSI=				0.68

Table A-3. HSI Calculation: Tree Savanna Cover Type

Cover Type: Tree Savanna						
Species: American Kestrel, Eastern Cottontail, Eastern Meadowlark, Scissor-tailed Flycatcher						
Variable	Area / Site Number					
	1	2	3	4		
American Kestrel						
Variable name	#	Value	Value	Value	Value	
Percent herbaceous canopy cover	V1	95	97	75	90	
Percent herbaceous canopy cover ≤ 30 cm (12 in) tall	V2	80	90	75	90	
Distance to nearest trees, fence post or utility poles/lines (km)	V4	0	0	0	0	
Availability of large lone trees (≥30 dbh) or groves (≤ 0.4 ha in size) containing large trees within a diameter of 1.6 km: A) Abundant: >10, B) Moderate: 4-9, C) Few to None: 0-1	V7	A	A	A	A	
Availability of cliff ledges, earth banks, or abandoned buildings within 1.6 km (1.0 mi): A) Abundant, B) Moderate, or C) Few to None	V8	C	C	C	B	
<i>Herbland / Savanna Model</i>		SI	SI	SI	SI	
	SI1	0.9	0.9	1.0	0.9	
	SI2	1.0	1.0	1.0	1.0	
	SI4	1.0	1.0	1.0	1.0	
	SI7	1.0	1.0	1.0	1.0	
	SI8	0.1	0.1	0.1	0.5	Average
<i>Food Value = (SI1 × SI2 × SI4)^{1/3}</i>		1.0	1.0	1.0	1.0	0.98
<i>Reproduction Value = SI7 + SI8 (max = 1.0)</i>		1.0	1.0	1.0	1.0	1.00
<i>See American Kestrel Multi-cover Type Worksheet</i>	HSI =					1.00
Eastern Cottontail						
Variable name	#	Value	Value	Value	Value	
Percent shrub (<16.5 ft height) crown cover	V1	1	25	3	5	
Percent tree (>16.5 ft height) canopy closure	V2	1	25	15	5	
Percent canopy closure of persistent herbaceous vegetation	V3	50	75	30	5	
		SI	SI	SI	SI	
	SI1	0.1	1.0	0.2	0.3	
	SI2	0.0	1.0	0.6	0.2	
	SI3	0.3	0.5	0.2	0.0	Average
<i>Winter Cover / Food Index = WCFI = ((4 × SI1 + SI2) ÷ 5) + SI3 [max=1.0]</i>		0.3	1.0	0.4	0.3	0.51
<i>See E. Cottontail Multi-cover Type Worksheet</i>	HSI =					0.31
Eastern Meadowlark						
Variable name	#	Value	Value	Value	Value	
Percent herbaceous canopy cover	V1	95	97	75	90	
Proportion of herbaceous canopy cover that is grass	V2	50	90	30	80	
Average height of herbaceous canopy (spring conditions) (cm)	V3	40.6	30.5	30.5	30.5	
Distance to perch site (m)	V4	9.1	1.5	3	0	
Percent shrub (<16.5 ft height) crown cover	V5	1	25	3	5	
		SI	SI	SI	SI	
	SI1	1.0	1.0	0.8	1.0	
	SI2	0.5	1.0	0.2	1.0	
	SI3	0.9	1.0	1.0	1.0	
	SI4	1.0	1.0	1.0	1.0	
	SI5	1.0	0.3	1.0	1.0	Average
<i>HSI = Food / Reproduction = (SI1 × SI2 × SI3 × SI4)^{1/2} × SI5</i>	HSI =	0.66	0.33	0.36	1.00	0.59
Scissor-tailed flycatcher						
Variable name	#	Value	Value	Value	Value	
Percent herbaceous canopy cover	V1	95	97	75	90	
Average height of herbaceous vegetation (cm)	V2	40.6	30.5	30.5	30.5	
Number of deciduous trees per acre (#/acre)	V3	10	150	20	1	
Distance to nearest deciduous trees (m)	V4	9.1	13.7	3.0	12.2	
<i>Model developed for Herbland/Savanna</i>		SI	SI	SI	SI	
	SI1	1.0	1.0	1.0	1.0	
	SI2	1.0	1.0	1.0	1.0	
	SI3	1.0	1.0	1.0	0.3	
	SI4	1.0	1.0	1.0	1.0	
<i>Food Value = (SI1 × SI2)^{1/2}</i>		1.0	1.0	1.0	1.0	
<i>Cover and Reproduction Value = SI3 + SI4 (max = 1.0)</i>		1.0	1.0	1.0	1.0	Average
<i>Lowest Life Requisite Value</i>	HSI =	1.00	1.00	1.00	1.00	1.00

Table A-4. HSI Calculation: Shrubland Cover Type

Cover Type: Shrubland						
Species: Eastern Cottontail, Field Sparrow, Racer						
Variable	#	Area / Site Number				
		SH 1	SH 2	SH 3	SH 5	
Eastern Cottontail						
Variable name	#	Value	Value	Value	Value	
Percent shrub (<16.5 ft height) crown cover	V1	40	75	35	25	
Percent tree (>16.5 ft height) canopy closure	V2	10	0	0	0	
Percent canopy closure of persistent herbaceous vegetation	V3	75	50	60	50	
		SI	SI	SI	SI	
	SI1	1.0	0.8	1.0	1.0	
	SI2	0.4	0.0	0.0	0.0	
	SI3	0.5	0.3	0.4	0.3	Average
Winter Cover / Food Index = WCFI <i>= ((4 × SI1 + SI2) ÷ 5) + SI3 [max=1.0]</i>		1.0	0.9	1.0	1.0	0.99
See Eastern Cottontail Multi-cover Type Worksheet		HSI =				0.31
Field Sparrow						
Variable name	#	Value	Value	Value	Value	
Percent shrub crown cover	V1	40	75	35	25	
Percent of total shrubs that are less than 1.5 m (4.9 ft) tall	V2	15	50	15	30	
Percent canopy cover of grasses	V3	20	40	75	90	
Average height of herbaceous canopy in spring (cm)	V4	38.1	91.4	91.4	20.3	
		SI	SI	SI	SI	
	SI1	0.9	0.0	1.0	1.0	
	SI2	0.4	1.0	0.4	0.7	
	SI3	0.4	0.8	1.0	1.0	
	SI4	0.6	0.5	0.5	1.0	Average
HSI = Cover/Reproduction Value <i>= [Min(SI1,SI2) × Min(SI3,SI4)]^{1/2}</i>		HSI = 0.42	0.00	0.47	0.82	0.43
Racer						
Variable name	#	Value	Value	Value	Value	
Percent herbaceous canopy cover	V1	90	100	95	70	
Average height of herbaceous canopy (meters)	V2	0.4	0.9	0.9	0.2	
Distance to shrubby edges or shrub thickets (feet)	V3	20	300	0	20	
Number of refuge sites per acre (#/acre)	V4	30	100	10	40	
		SI	SI	SI	SI	
	SI1	1.0	1.0	1.0	1.0	
	SI2	0.3	0.8	0.8	0.2	
	SI3	1.0	1.0	1.0	1.0	
Winter Cover Value		SI4	1.0	1.0	1.0	1.0
Food Value = [2 × (SI1 × SI2)^{1/2} + SI3] ÷ 2			1.0	1.0	1.0	0.9
Lowest Life Requisite Value		HSI=	1.00	1.00	1.00	0.92
						0.98

Table A-5. HSI Calculation: Cropland Cover Type

Cover Type: Cropland					
Species: American Kestrel, Eastern Cottontail, Scissor-tailed Flycatcher					
Variable	Area / Site Number				
	1	4	20		
American Kestrel					
Variable name	#	Value	Value	Value	
Distance to nearest trees, forest edge, fence post or utility poles and lines (km)	V4	0.0	0.1	0.1	
Availability of fence rows, roadside ditches, and grassy-uncultivated areas: A) Abundant, B) Moderate, C) Scarce to None	V5	A	A	A	
Availability of large lone trees (≥30 dbh) or groves (≤ 0.4 ha in size) containing large trees within a diameter of 1.6km: A) Abundant: >10, B) Moderate: 4-9, C) Few to None: 0-1	V7	A	A	A	
Availability of cliff ledges, earth banks, or abandoned buildings w/in 1.6 km (1. mi): A) Abundant, B) Moderate, C) Few to None	V8	C	C	C	
		SI	SI	SI	
	SI4	1.0	1.0	1.0	
	SI5	1.0	1.0	1.0	
	SI7	1.0	1.0	1.0	
	SI8	0.1	0.1	0.1	Average
Food Value = $0.5 \times (SI4 + SI5) \div 2$		0.5	0.5	0.5	0.50
Reproduction Value = $SI7 + SI8$ (max = 1.0)		1.0	1.0	1.0	1.00
See American Kestrel Multi-cover Type Worksheet	HSI =				1.00
Eastern Cottontail					
Variable name	#	Value	Value	Value	
Percent shrub (<16.5 ft height) crown cover	V1	0	0	0	
Percent tree (>16.5 ft height) canopy closure	V2	0	0	0	
Percent canopy closure of persistent herbaceous vegetation	V3	40	90	10	
		SI	SI	SI	
	SI1	0.0	0.0	0.0	
	SI2	0.0	0.0	0.0	
	SI3	0.2	0.5	0.1	Average
Winter Cover / Food Index = WCFI = $((4 \times SI1 + SI2) \div 5) + SI3$ [max=1.0]		0.2	0.5	0.1	0.28
See E. Cottontail Multi-cover Type Worksheet	HSI =				0.31
Scissor-tailed flycatcher					
Variable name	#	Value	Value	Value	
Percent herbaceous canopy cover	V1	20	95	25	
Average height of herbaceous vegetation (cm)	V2	45.7	91.4	30.5	
Number of deciduous trees per acre (#/acre)	V3	0	0	0	
Distance to nearest deciduous trees (m)	V4	45.7	99.7	91.4	
		SI	SI	SI	
	SI1	0.5	1.0	0.6	
	SI2	1.0	1.0	1.0	
	SI3	0.0	0.0	0.0	
	SI4	1.0	1.0	1.0	
Food Value = $(SI1 \times SI2)^{1/2}$		0.7	1.0	0.8	
Cover and Reproduction Value = $SI3 + SI4$ (max = 1.0)		1.0	1.0	1.0	Average
Lowest Life Requisite Value	HSI=	0.71	1.00	0.79	0.83

Table A-6. HSI Calculation: Grassland / Old Field Cover Type

Cover Type: Grassland / Old Field

Species: American Kestrel, Eastern Cottontail, Eastern Meadowlark, Racer, Scissor-tailed Flycatcher

Variable	#	Area / Site Number															
		CR2	CR3	1	2	3	4	5	6	7	8	11	12	13	14	15	16
American Kestrel																	
Variable name	#	Field Variable Values															
Percent herbaceous canopy cover	V1	75	90	90	90	100	60	95	95	97	98	100	90	30	98	95	90
Percent herbaceous canopy cover ≤ 12 in tall	V2	90	90	90	88	100	0	90	95	97	85	100	85	100	92	95	50
Distance to nearest trees, forest edge, fence post or utility poles and lines (km)	V4	0.0	0.0	0.0	0.0	0.1	0.1	0.1	0.0	0.1	0.0	0.0	0.0	0.0	0.1	0.1	
Availability of large lone trees (≥30 dbh) or groves (≤ 0.4 ha in size) with large trees within 1.6 km: A) Abundant: >10, B) Moderate: 4-9, or C) Few to None: 0-1	V7	A	A	A	A	A	A	A	A	A	A	A	A	A	A	A	
Availability of cliff ledges, earth banks, or old abandoned buildings within 1.6 km (1.0 mi): A) Abundant, B) Moderate, or C) Few to None	V8	C	C	C	C	C	C	C	C	C	C	C	C	B	C	C	
<i>Herbland / Savanna Madel</i>																	
		SI Values															
	SI1	1.0	0.9	0.9	0.9	0.9	1.0	0.9	0.9	0.9	0.9	0.9	0.9	0.4	0.9	0.9	0.9
	SI2	1.0	1.0	1.0	1.0	1.0	0.3	1.0	1.0	1.0	1.0	1.0	1.0	1.0	1.0	1.0	0.6
	SI4	1.0	1.0	1.0	1.0	1.0	1.0	1.0	1.0	1.0	1.0	1.0	1.0	1.0	1.0	1.0	1.0
	SI7	1.0	1.0	1.0	1.0	1.0	1.0	1.0	1.0	1.0	1.0	1.0	1.0	1.0	1.0	1.0	1.0
	SI8	0.1	0.1	0.1	0.1	0.1	0.1	0.1	0.1	0.1	0.1	0.1	0.1	0.5	0.1	0.1	0.1
<i>Food Value = (SI1 × SI2 × SI4)^{1/3}</i>		1.0	1.0	1.0	1.0	1.0	0.7	1.0	1.0	1.0	1.0	1.0	1.0	0.8	1.0	1.0	0.8
<i>Reproduction Value = SI7 + SI8 (max = 1.0)</i>		1.0	1.0	1.0	1.0	1.0	1.0	1.0	1.0	1.0	1.0	1.0	1.0	1.0	1.0	1.0	1.0
	HSI =	<i>See American Kestrel Multi-cover Type Worksheet</i>															
Eastern Cottontail																	
Variable name	#	Field Variable Values															
Percent shrub (<16.5 ft height) crown cover	V1	0	1	0	0	0	0	0	0	0	0	15	0	0	2	0	0
Percent tree (>16.5 ft height) canopy closure	V2	0	0	0	0	0	0	0	0	0	0	0	0	0	0	0	0
Percent canopy closure of persistent herbaceous vegetation	V3	0	90	0	50	100	25	35	75	30	70	75	25	10	40	5	80
		SI Values															
	SI1	0.0	0.1	0.0	0.0	0.0	0.0	0.0	0.0	0.0	0.0	0.8	0.0	0.0	0.1	0.0	0.0
	SI2	0.0	0.0	0.0	0.0	0.0	0.0	0.0	0.0	0.0	0.0	0.0	0.0	0.0	0.0	0.0	0.0
	SI3	0.0	0.5	0.0	0.3	0.6	0.2	0.2	0.5	0.2	0.4	0.5	0.2	0.1	0.2	0.0	0.5
<i>Winter Cover / Food Index (WCFI) = ((4 × SI1 + SI2) ÷ 5) + SI3 [max=1.0]</i>		0.0	0.6	0.0	0.3	0.6	0.2	0.2	0.5	0.2	0.4	1.0	0.2	0.1	0.3	0.0	0.5
	HSI =	<i>See Eastern Cottontail Multi-cover Type Worksheet</i>															
Eastern Meadowlark																	
Variable name	#	Field Variable Values															
Percent herbaceous canopy cover	V1	75	90	90	90	100	60	95	95	97	98	100	90	30	98	95	90
Proportion of herbaceous cover that is grass	V2	99	25	88	80	75	5	90	95	98	80	10	40	80	92	95	20
Average height of herbaceous canopy in spring conditions (cm)	V3	30.5	61.0	15.2	30.5	61.0	20.3	30.5	30.5	20.3	20.3	61.0	40.6	30.5	30.5	20.3	40.6
Distance to perch site (m)	V4	26.5	45.7	27.4	22.9	55.8	64.0	53.0	35.7	91.4	12.2	15.2	38.4	45.7	5.2	69.5	57.6
Percent shrub (<16.5 ft height) crown cover	V5	0	1	0	0	0	0	0	0	0	0	15	0	0	2	0	0
		SI Values															
	SI1	0.8	1.0	1.0	1.0	1.0	0.6	1.0	1.0	1.0	1.0	1.0	1.0	0.1	1.0	1.0	1.0
	SI2	1.0	0.1	1.0	1.0	0.9	0.0	1.0	1.0	1.0	1.0	0.0	0.3	1.0	1.0	1.0	0.0
	SI3	1.0	0.4	1.0	1.0	0.4	1.0	1.0	1.0	1.0	1.0	0.4	0.9	1.0	1.0	1.0	0.9
	SI4	1.0	0.6	1.0	1.0	0.3	0.2	0.4	0.8	0.2	1.0	1.0	0.8	0.6	1.0	0.2	0.3
	SI5	1.0	1.0	1.0	1.0	1.0	1.0	1.0	1.0	1.0	0.7	1.0	1.0	1.0	1.0	1.0	1.0
<i>HSI = Food / Reproduction = (SI1 × SI2 × SI3 × SI4)^{1/2} × SI5</i>	HSI =	0.89	0.13	1.00	1.00	0.32	0.00	0.62	0.92	0.45	1.00	0.00	0.47	0.29	1.00	0.45	0.00
	Average																

(Table A-6. HSI Calculation: Grassland / Old Field Cover Type, Continued)

Cover Type: Grassland / Old Field																	
Species: American Kestrel, Eastern Cottontail, Eastern Meadowlark, Racer, Scissor-tailed Flycatcher																	
Variable		Area / Site Number															
		CR2	CR3	1	2	3	4	5	6	7	8	11	12	13	14	15	16
Racer																	
Variable name	#	Field Variable Values															
Percent herbaceous canopy cover	V1	75	90	90	90	100	60	95	95	97	98	100	90	30	98	95	90
Average height of herbaceous canopy (m)	V2	0.3	0.6	0.2	0.3	0.6	0.2	0.3	0.3	0.2	0.2	0.6	0.4	0.3	0.3	0.2	0.4
Dist. to shrubby edges or shrub thickets (ft)	V3	825	537	600	75	100	810	450	321	300	100	50	120	150	273	500	200
Number of refuge sites per acre (#/acre)	V4	0	0	0	10	0	0	0	0	0	0	100	0	10	0	0	0
		SI Values															
	SI1	1.0	1.0	1.0	1.0	1.0	0.9	1.0	1.0	1.0	1.0	1.0	1.0	0.5	1.0	1.0	1.0
	SI2	0.3	0.5	0.1	0.3	0.5	0.2	0.3	0.3	0.2	0.2	0.5	0.4	0.3	0.3	0.2	0.4
	SI3	0.5	0.8	0.7	1.0	1.0	0.5	0.9	1.0	1.0	1.0	1.0	1.0	1.0	1.0	0.8	1.0
	SI4	0.0	0.0	0.0	1.0	0.0	0.0	0.0	0.0	0.0	0.0	1.0	0.0	1.0	0.0	0.0	0.0
Winter Cover Value	SI4	0.0	0.0	0.0	1.0	0.0	0.0	0.0	0.0	0.0	0.0	1.0	0.0	1.0	0.0	0.0	0.0
Food Value = $[2 \times (SI1 \times SI2)^{1/2} + SI3] \div 2$		0.8	1.0	0.7	1.0	1.0	0.7	1.0	1.0	0.9	0.9	1.0	1.0	0.9	1.0	0.8	1.0
Lowest Life Requisite Value	HSI=	0.00	0.00	0.00	1.00	0.00	0.00	0.00	0.00	0.00	0.00	1.00	0.00	0.86	0.00	0.00	0.00
Scissor-tailed flycatcher																	
Variable name	#	Field Variable Values															
Percent herbaceous canopy cover	V1	75	90	90	90	100	60	95	95	97	98	100	90	30	98	95	90
Average height of herbaceous vegetation (cm)	V2	30.5	61.0	15.2	30.5	61.0	20.3	30.5	30.5	20.3	20.3	61.0	40.6	30.5	30.5	20.3	40.6
Number of deciduous trees per acre (#/acre)	V3	0	0	0	0	0	0	0	0	0	0	0	0	0	0	0	0
Distance to nearest deciduous trees (m)	V4	26.5	118.9	27.4	22.9	55.8	64.0	53.0	58.5	91.4	24.4	15.2	38.4	45.7	36.6	94.2	57.6
Model developed for Herbland/Savanna		SI Values															
	SI1	1.0	1.0	1.0	1.0	1.0	1.0	1.0	1.0	1.0	1.0	1.0	1.0	0.8	1.0	1.0	1.0
	SI2	1.0	1.0	0.9	1.0	1.0	1.0	1.0	1.0	1.0	1.0	1.0	1.0	1.0	1.0	1.0	1.0
	SI3	0.0	0.0	0.0	0.0	0.0	0.0	0.0	0.0	0.0	0.0	0.0	0.0	0.0	0.0	0.0	0.0
	SI4	1.0	1.0	1.0	1.0	1.0	1.0	1.0	1.0	1.0	1.0	1.0	1.0	1.0	1.0	1.0	1.0
Food Value = $(SI1 \times SI2)^{1/2}$		1.0	1.0	0.9	1.0	1.0	1.0	1.0	1.0	1.0	1.0	1.0	1.0	0.9	1.0	1.0	1.0
Cover and Reproduction Value = $SI3 + SI4$ (max = 1.0)		1.0	1.0	1.0	1.0	1.0	1.0	1.0	1.0	1.0	1.0	1.0	1.0	1.0	1.0	1.0	1.0
Lowest Life Requisite Value	HSI=	1.00	0.96	0.92	1.00	1.00	1.00	1.00	1.00	1.00	1.00	1.00	1.00	0.87	1.00	1.00	1.00

Table A-7. HSI Calculation: Riparian Woodland Cover Type

Cover Type: Riparian Woodland																	
Species: Barred Owl, Downy Woodpecker, Fox Squirrel, Raccoon, Wood Duck																	
Variable	Area / Site Number																
	1	2	3	4	5	6	7	8	9	11	12	14	15	20	30		
Barred Owl																	
Variable name	#	Field Variable Values															
Number of tree >20" dbh/acre	V1	0	10	0	10	0	0	0	10	0	20	0	0	0	0	0	
Average dbh of overstory trees (in)	V2	8	8	8	9	8	4	5	8	8	15	10	8	12	20	5	
Percent canopy cover of overstory trees	V3	50	60	60	20	10	75	80	80	40	40	75	55	40	30	60	
		SI Values															
	SI1	0.1	1.0	0.1	1.0	0.1	0.1	0.1	1.0	0.1	1.0	0.1	0.1	0.1	0.1	0.1	
	SI2	0.2	0.2	0.2	0.3	0.2	0.0	0.0	0.2	0.2	0.7	0.3	0.2	0.5	1.0	0.0	
	SI3	0.8	1.0	1.0	0.0	0.0	1.0	1.0	1.0	0.5	0.5	1.0	0.9	0.5	0.3	1.0	
<i>HSI = Repr. Suitability Index</i> <i>= (SI1 × SI2)^{1/2} × SI3</i>	HSI =	0.11	0.45	0.14	0.00	0.00	0.00	0.00	0.45	0.07	0.41	0.18	0.12	0.11	0.08	0.00	0.14
Downy Woodpecker																	
Variable name	#	Field Variable Values															
Basal area (ft ² per acre)	V1	120	170	180	120	10	80	50	90	2	150	60	150	150	20	110	
Number of snags >6 in dbh/acre	V2	40	120	20	20	30	0	10	0	10	30	1	0	40	30	0	
		SI Values															
<i>Food Value</i>	SI1	0.6	0.5	0.5	0.6	0.2	1.0	1.0	1.0	0.0	0.5	1.0	0.5	0.5	0.5	0.7	
<i>Reproduction Value</i>	SI2	1.0	1.0	1.0	1.0	1.0	0.0	1.0	0.0	1.0	0.2	0.0	1.0	1.0	0.0	0.0	
<i>Lowest Life Requisite Value</i>	HSI =	0.62	0.50	0.50	0.62	0.23	0.00	1.00	0.00	0.05	0.50	0.20	0.00	0.50	0.45	0.00	0.34
Fox Squirrel																	
Variable name	#	Field Variable Values															
Percent canopy closure of trees that produce hard mast >10 in dbh	V1	0	0	0	0	0	0	0	0	0	0	0	0	0	0	0	
Distance to available grain (yd)	V2	660	660	660	660	660	660	660	660	660	660	660	660	660	660	660	
Average dbh of overstory trees (in)	V3	8	8	8	9	8	4	5	8	8	15	10	8	12	20	5	
Percent tree (>16.5 ft height) canopy closure	V4	60	85	90	50	10	80	95	80	85	50	80	60	70	70	60	
Percent shrub (<16.5 ft height) crown cover	V5	10	5	5	5	80	5	10	20	10	60	10	10	10	25	15	
		SI Values															
	SI1	0.0	0.0	0.0	0.0	0.0	0.0	0.0	0.0	0.0	0.0	0.0	0.0	0.0	0.0	0.0	
	SI2	0.1	0.1	0.1	0.1	0.1	0.1	0.1	0.1	0.1	0.1	0.1	0.1	0.1	0.1	0.1	
	SI3	0.1	0.1	0.1	0.2	0.1	0.0	0.0	0.1	0.1	1.0	0.3	0.1	0.6	1.0	0.0	
	SI4	1.0	0.7	0.6	1.0	0.5	0.8	0.6	0.8	0.7	1.0	0.8	1.0	0.9	0.9	1.0	
	SI5	1.0	1.0	1.0	1.0	0.2	1.0	1.0	1.0	1.0	0.5	1.0	1.0	1.0	1.0	1.0	
<i>Winter Food</i> <i>= (3 × SI1 + SI2) ÷ 3</i>		0.0	0.0	0.0	0.0	0.0	0.0	0.0	0.0	0.0	0.0	0.0	0.0	0.0	0.0	0.0	
<i>Cover/Reproduction Value</i> <i>= (SI3 × SI4 × SI5)^{1/3}</i>		0.4	0.4	0.3	0.6	0.2	0.0	0.0	0.4	0.4	0.8	0.6	0.4	0.8	1.0	0.0	
<i>Lowest Life Requisite Value</i>	HSI =	0.03	0.03	0.03	0.03	0.03	0.00	0.00	0.03	0.03	0.03	0.03	0.03	0.03	0.03	0.00	0.03

(Table A-7. HSI Calculation: Riparian Woodland Cover Type, Continued)

Cover Type: Riparian Woodland																	
Species: Barred Owl, Downy Woodpecker, Fox Squirrel, Raccoon, Wood Duck																	
Variable	Area / Site Number																
	1	2	3	4	5	6	7	8	9	11	12	14	15	20	30		
Raccoon																	
Variable name	#	Field Variable Values															
Distance to water (mi)	V1	0.0	0.3	0.0	0.0	0.0	0.1	0.0	0.1	0.1	0.0	0.1	0.3	0.0	0.0	0.1	
Water regime: A) Permanent water, B) Semi-permanent water, or C) No water or ephemeral flooding	V2	B	B	B	B	B	B	B	B	A	C	B	B	B	B	B	
Overstory forest size class: A) Saplings (<15cm dbh), B) Pole timber (≥ 15 cm to 25 cm dbh), C) Saw timber (≥ 25 cm to 50 cm dbh), or D) Mature trees (≥ 50 cm dbh).	V3	B	B	B	B	B	A	A	B	B	C	B	B	C	C	A	
Number of refuge sites per 0.4 ha (#/acre)	V4	10	10	70	3	60	20	120	30	100	20	20	0	20	40	0	
<i>Deciduous Forested Wetlands Model</i>	SI Values																
	SI 1	1.0	1.0	1.0	1.0	1.0	1.0	1.0	1.0	1.0	1.0	1.0	1.0	1.0	1.0	1.0	
	SI 2	0.5	0.5	0.5	0.5	0.5	0.5	0.5	0.5	1.0	0.1	0.5	0.5	0.5	0.5	0.5	
	SI 3	0.2	0.2	0.2	0.2	0.2	0.1	0.1	0.2	0.2	0.7	0.2	0.2	0.7	0.7	0.1	
	SI 4	1.0	1.0	1.0	0.9	1.0	1.0	1.0	1.0	1.0	1.0	0.0	0.0	1.0	1.0	0.0	
<i>Water Value = (SI1 × SI2)^{1/2}</i>		0.7	0.7	0.7	0.7	0.7	0.7	0.7	0.7	1.0	0.3	0.7	0.7	0.7	0.7	0.7	
<i>Cover Reproduction Value = (SI3 + SI4) ÷ 2</i>		0.6	0.6	0.6	0.6	0.6	0.6	0.6	0.6	0.6	0.9	0.6	0.1	0.9	0.9	0.1	
<i>Lowest Life Requisite Value</i>	HSI=	0.60	0.60	0.60	0.55	0.60	0.55	0.55	0.60	0.60	0.32	0.60	0.10	0.71	0.71	0.05	0.52
Wood Duck																	
Variable name	#	Field Variable Values															
Number of potentially suitable tree cavities per acre (min entrance size of 7.6 × 10 cm)	V1	0	0	0	1	0	0	30	20	0	40	10	0	0	20	0	
Number of nest boxes per acre	V2																
Number of potential nest sites per acre = (0.18 × V1) + (0.95 × V2)	V3	0.0	0.0	0.0	0.2	0.0	0.0	5.4	3.6	0.0	7.2	1.8	0.0	0.0	3.6	0.0	
Percent of water surface covered by potential brood cover	V4	15	0	5	0	10	15	5	25	5	80	10	5	5	5	10	
Percent of water surface covered by potential winter cover	V5	8	0	3	0	10	15	5	15	5	65	8	5	5	5	10	
	SI Values																
<i>Nesting Value</i>	SI3	0.0	0.0	0.0	0.0	0.0	0.0	1.0	0.7	0.0	1.0	0.4	0.0	0.0	0.7	0.0	0.26
<i>Brooding Value</i>	SI4	0.3	0.0	0.1	0.0	0.2	0.3	0.1	0.5	0.1	0.8	0.2	0.1	0.1	0.1	0.2	0.21
<i>Winter Cover Value</i>	SI5	0.2	0.0	0.1	0.0	0.2	0.3	0.1	0.3	0.1	1.0	0.2	0.1	0.1	0.1	0.2	0.19
	HSI =	See Wood Duck Multi-cover Type Worksheet														0.22	

Table A-8. HSI Calculation: Shrub Wetland Cover Type

Cover Type: Shrub Wetland

Species: Green Heron, Raccoon, Swamp Rabbit, Wood Duck

Variable	#	Area / Site Number					
		1	2	3	4	5	
Green Heron							
Variable name	#	Value	Value	Value	Value	Value	
Aquatic substrate composition in littoral zone: A) Muddy, B) Sandy, or C) Rocky	V1	A	A	A	A	A	
Percent water area <10 in deep	V2	100	100	100	100	100	
Percent emergent herbaceous canopy cover in littoral zone	V3	25	60	100	60	0	
Percent water surface obstruction	V4	25	0	95	50	40	
Water regime: A) Permanent water, B) Semi-permanent water, or C) No water or ephemeral flooding	V5	B	B	B	A	B	
Water current in summer: A) Still to slow (<6 in/sec), B) Moderately slow (2-24 in/sec), C) Moderately fast (24-40 in/sec), or D) Fast (>40 in/sec)	V6	A	A	A	A	A	
		SI	SI	SI	SI	SI	
	SI1	1.0	1.0	1.0	1.0	1.0	
	SI2	1.0	1.0	1.0	1.0	1.0	
	SI3	0.6	1.0	0.0	1.0	0.1	
	SI4	1.0	0.2	0.2	1.0	1.0	
	SI5	0.9	0.9	0.9	1.0	0.9	
	SI6	1.0	1.0	1.0	1.0	1.0	
Food Value = (SI1 × SI2 × SI3) ^{1/3} + SI4		1.0	1.0	0.2	1.0	1.0	
Water Value = (SI5 × SI6) ^{1/2}		0.9	0.9	0.9	1.0	0.9	Average
Lowest Life Requisite Value	HSI =	0.95	0.95	0.20	1.00	0.95	0.81
Raccoon							
Variable name	#	Value	Value	Value	Value	Value	
Distance to water (mi)	V1	0.3	0.0	0.0	0.1	0.0	
Water regime: A) Permanent water, B) Semi-permanent water, or C) No water or ephemeral flooding	V2	B	B	B	A	B	
Number of refuge sites per 0.4 ha (#/acre)	V4	0	0	30	0	50	
<i>Deciduous Shrub Wetland Model</i>		SI	SI	SI	SI	SI	
	SI 1	1.0	1.0	1.0	1.0	1.0	
	SI 2	0.5	0.5	0.5	1.0	0.5	
Cover / Reproduction Value	SI 4	0.0	0.0	1.0	0.0	1.0	
Water Value = (SI1 × SI2) ^{1/2}		0.7	0.7	0.7	1.0	0.7	Average
Lowest Life Requisite Value	HSI=	0.00	0.00	0.71	0.00	0.71	0.28
Swamp Rabbit							
Variable name	#	Value	Value	Value	Value	Value	
Percent shrub crown closure	V2	65	60	45	90	40	
Percent herbaceous canopy cover	V3 / V4	10	67	100	60	100	
Water Regime: 1) Permanently flooded, 2) Intermittently exposed, 3) Semi-permanently flooded, 4) seasonally flooded, 5) Temporarily flooded, or 6) Intermittently flooded	V6	4	3	3	4	3	
<i>Deciduous Shrub Wetland Model</i>		SI	SI	SI	SI	SI	
	SI2	1.0	1.0	0.9	1.0	0.8	
	SI3 / SI4	0.1	0.9	1.0	0.8	1.0	
	SI6	0.8	0.5	0.5	0.8	0.5	
Food/Cover Value = (SI1 + SI2) ÷ 2		0.6	0.9	1.0	0.9	0.9	Average
HSI = Food/Cover Index × SI6	HSI =	0.45	0.47	0.48	0.72	0.46	0.52
Wood duck							
Variable name	#	Value	Value	Value	Value	Value	
Number of potentially suitable tree cavities per acre (min entrance size of 7.6 × 10 cm)	V1	0	0	0	0	0	
Number of nest boxes per acre	V2	0	0	0	0	0	
Number of potential nest sites per acre = (0.18 × V1) + (0.95 × V2)	V3	0	0	0	0	0	
Percent of water surface covered by potential brood cover	V4	25	0	95	50	40	
Percent of water surface covered by potential winter cover	V5	25	0	60	25	40	
		SI	SI	SI	SI	SI	Average
Nesting Value	SI3	0.0	0.0	0.0	0.0	0.0	0.00
Brooding Value	SI4	0.5	0.0	0.2	1.0	0.8	0.50
Winter Cover Value	SI5	0.5	0.0	1.0	0.5	0.8	0.56
See Wood Duck Multi-cover Type Worksheet	HSI =						0.22

Table A-9. HSI Calculation: Emergent Wetlands Cover Type

Emergent Wetlands								
Species: Green Heron, Racoon, Wood Duck								
Variable		Area / Site Number						
		1	2	3	4	5	75	
Green Heron								
Variable name	#	Value	Value	Value	Value	Value	Value	
Aquatic substrate composition in littoral zone A) Muddy, B) Sandy, or C) Rocky	V1	A	A	A	A	A	A	
Percent water area <10 in deep	V2	100	100	100	100	25	15	
Percent emergent herbaceous canopy cover in littoral zone	V3	75	90	50	95	50	20	
Percent water surface obstruction	V4	75	90	0	2	15	5	
Water regime (average summer conditions): A) No water or ephemeral flooding, B) Semi-permanent water, or C) Permanent water	V5	B	B	B	C	B	A	
Water current (average summer conditions): A) Still to slow (<6 in/sec), B) Moderately slow (2-24 in/sec), C) Moderately fast (24-40 in/sec), or D) Fast (>40 in/sec)	V6	A	A	A	A	A	A	
Distance to deciduous forested or deciduous shrub wetland (mi)	V7	0.0	0.1	0.0	0.0	0.0	0.0	
		SI	SI	SI	SI	SI	SI	
	SI1	1.0	1.0	1.0	1.0	1.0	1.0	
	SI2	1.0	1.0	1.0	1.0	0.5	0.3	
	SI3	1.0	0.4	1.0	0.2	1.0	0.5	
	SI4	1.0	0.4	0.2	0.3	0.7	0.4	
	SI5	0.9	0.9	0.9	0.3	0.9	1.0	
	SI6	1.0	1.0	1.0	1.0	1.0	1.0	
Reproduction Value	SI7	1.0	1.0	1.0	1.0	1.0	1.0	
Food Value = (SI1 × SI2 × SI3) ^{1/3} + SI4		1.0	1.0	1.0	0.8	1.0	0.9	
Water Value = (SI5 × SI6) ^{1/2}		0.9	0.9	0.9	0.5	0.9	1.0	Average
Lowest Requisite Life Value	HSI =	0.95	0.95	0.95	0.55	0.95	0.87	0.87
Racoon								
Variable name	#	Value	Value	Value	Value	Value	Value	
Distance to water (mi)	V1	0	0	0	0	0	0	
Water regime: A) Permanent water, B) Semi-permanent water, or C) No water or ephemeral flooding	V2	B	B	B	C	B	A	
Number of refuge sites per 0.4 ha (#/acre)	V4	0	0	0	20	50	0	
<i>Herbaceous Wetland Model</i>		SI	SI	SI	SI	SI	SI	
	SI 1	1.0	1.0	1.0	1.0	1.0	1.0	
	SI 2	0.5	0.5	0.5	0.1	0.5	1.0	
Cover / Reproduction Value	SI 4	0.0	0.0	0.0	1.0	1.0	0.0	
Water Value = (SI1 × SI2) ^{1/2}		0.7	0.7	0.7	0.3	0.7	1.0	Average
Lowest Requisite Life Value	HSI=	0.00	0.00	0.00	0.32	0.71	0.00	0.17
Wood Duck								
Variable name	#	Value	Value	Value	Value	Value	Value	
Number of potentially suitable tree cavities per acre (min entrance size of 7.6 × 10 cm)	V1	0	0	0	10	0	0	
Number of nest boxes per acre	V2							
Number of potential nest sites per acre = (0.18 × V1) + (0.95 × V2)	V3	0	0	0	1.8	0	0	
Percent of water surface covered by potential brood cover	V4	75	90	0	2	15	5	
Percent of water surface covered by potential winter cover	V5	20	75	0	2	15	5	
		SI	SI	SI	SI	SI	SI	Average
Nesting Value	SI3	0.0	0.0	0.0	0.4	0.0	0.0	0.06
Brooding Value	SI4	1.0	0.4	0.0	0.0	0.3	0.1	0.31
Winter Cover Value	SI5	0.4	1.0	0.0	0.0	0.3	0.1	0.31
<i>See Wood Duck Multi-cover Type Worksheet</i>	HSI =							0.22

Table A-10. American Kestrel Multi-cover Type Worksheet

American Kestrel	Cover Type			
Relative Abundance of Cover Types	Cropland	Grassland	Tree Savanna	Total
Area Used By Species (acres)	1757.0	4761.0	132.0	6650.00
Relative Area = Cover Type Area ÷ Total Area	0.3	0.7	0.0	1.00
Food Value Calculation				
Food Value 1 From Cover Type Worksheet	0.5	0.9	1.0	
Mean Distance to Covertype Providing Food (mi)	0.0	0.0	0.0	
Interspersion Index Value of Index at Distance	1.0	1.0	1.0	
Food Value 2 At Cover Type Providing Food Habitat	0.5	0.9	1.0	
Modified Food Value = Interspersion Index × Food Value 2	0.5	0.9	1.0	Total
% Food Support Provided = Modified Food Value × Relative Area	0.1	0.7	0.0	0.82
Reproduction Value Calculation				
Reproduction Value 1 From Cover Type Worksheet	1.0	1.0	1.0	
Mean Distance to Covertype Providing Reproduction (mi)	0.0	0.0	0.0	
Interspersion Index Value of Index at Distance	1.0	1.0	1.0	
Reproduction Value 2 At Cover Type Providing Reproduction Habitat	1.0	1.0	1.0	
Modified Reproduction Value = Interspersion Index × Reproduction Value 2	1.0	1.0	1.0	Total
% Reproduction Support Provided = Modified Reproduction Value × Relative Area	0.3	0.7	0.0	1.00
Overall Life Requisite Calculation	% Provided Calculated Above	Optimal % Provided in Model	Overall Life Requisite Value = Provided ÷ Optimal	
Food Value	0.8	0.6	1.0	
Reproduction Value	1.0	0.1	1.0	
HSI = Lowest Requisite Life Value			1.00	

Table A-11. Wood Duck Multi-cover Type Worksheet

Wood Duck	Cover Type			Total
	Riparian Woodland	Shrub Wetland	Herbaceous Wetland	
Relative Abundance of Cover Types				
Area Used By Species (acres)	6330.0	49.0	1223.0	7602.0
Relative Area = Cover Type Area ÷ Total Area	0.8	0.0	0.2	1.0
Winter Cover Value Calculation				
Winter Cover Value (SI5) From Cover Type Worksheet	0.2	0.6	0.3	Total
Winter Cover Value Adjusted by Area = SI5 × Relative Area	0.2	0.00	0.0	0.2

Nesting Value Calculation

Nesting Value (SI3) From Cover Type Worksheet	0.3	0.0	0.1		
Interspersion Index for Nesting* =1 if Nesting Provided in Covertype or Within 0.5 mi	1.0	1.0	1.0		
Usable Relative Area = Relative Area × Interspersion Index	0.8	0.0	0.2	Total	
Nesting Value Adjusted by Usable Area = SI3 × Usable Relative Area	0.2	0.0	0.0	0.2	
% Area in Optimum Condition for Nesting (V7) = Sum of Adjusted Nesting Values × 100				V7	22.3
Overall Nesting Value (SI7) = Calculated for V7 from Model				SI7	1.0

Brooding Value Calculation

Brooding Value (SI4) From Cover Type Worksheet	0.2	0.5	0.3		
Interspersion Index for Brooding =1 if Brooding Provided in Covertype or Within 0.5 mi	1.0	1.0	1.0		
Usable Relative Area = Relative Area × Interspersion Index	0.8	0.0	0.2	Total	
Brooding Value Adjusted by Area = SI4 × Relative Area	0.2	0.0	0.0	0.2	
% Area in Optimum Condition for Brooding (V8) = Sum of Adjusted Brooding Values × 100				V8	22.5
Overall Brooding Value (SI8) = Calculated for V8 from Model				SI8	0.2

Year-Round HSI Calculation

Breeding Suitability Value = Lowest Life Requisite Value for Breeding (Nesting or Brooding)	0.2
Winter Cover Suitability Value = Sum of Adjusted Winter Cover Values	0.2
Highest Life Requisite Value = HSI =	0.22

Table A-12. Eastern Cottontail Multi-cover Type Worksheet

Eastern Cottontail	Cover Type					Total
	Evergreen Forest	Tree Savanna	Shrubland	Grassland	Cropland	
Winter Cover / Food Value Calculation						
Area Used By Species (acres)	228.0	132.0	63.0	4761.0	1757.0	6941.0
Relative Area = Cover Type Area ÷ Total Area	0.03	0.02	0.01	0.69	0.25	1.00
Winter Cover / Food Value (WCFI) From Cover Type Worksheet	0.37	0.51	0.99	0.31	0.28	Total
Weighted WCFI = WCFI × Relative Area	0.01	0.01	0.01	0.21	0.07	0.31
HSI = Weighted WCFI Total if all cover types provide WCFI						0.31

Table A-13. Eastern Wild Turkey Multi-cover Type Worksheet

Eastern Wild Turkey	Cover Type		Totals
	Evergreen Forest	Upland Deciduous Forest	
Area Used By Species (acres)	228.0	2216.0	2444.0
Relative Area = Cover Type Area ÷ Total Area	0.09	0.91	1.00
Summer Food / Brood Value (FBSI) From Cover Type Worksheet	0.00	0.43	Total
Adjusted FBSI = FBSI × Relative Area	0.00	0.39	0.39
Fall/Winter/Spring Food (FWSSI) Value From Cover Type Worksheet	0.43	0.59	Total
Adjusted FWSSI = FWSSI × Relative Area	0.04	0.53	0.57
Cover (CSI) Value From Cover Type Worksheet	0.04	0.89	Total
Adjusted CSI = CSI × Relative Area	0.00	0.81	0.81

% Area Providing Optimum Habitat for Life Requisite		
Summer Food/Brood = Sum of Adjusted FBSI	V14	38.6
Fall/Winter/Spring Food = Sum of Adjusted FWSSI	V15	57.4
Cover = Sum of Adjusted CSI	V16	81.4

Overall Life Requisite Values		
Summer Food/Brood Calculated for V14 from Model	SI14	1.00
Fall/Winter/Spring Food Calculated for V15 from Model	SI15	0.68
Cover Calculated for V16 from Model	SI16	1.00
<i>Lowest Requisite Life Value</i>	HSI=	0.68

Appendix B

Photographs of Evaluation Sites

Upland Deciduous Forest HEP Evaluation Sites



DOMINANT VEGETATION

TREES

Post Oak, Water Oak, Red Oak, Cedar Elm, Sugarberry, Bois d'Arc, Green Ash, and Eastern Red Cedar

SHRUBS & VINES

Coralberry, Greenbrier, Honey Locust, Poison Ivy, Virginia Creeper, and Dogwood

HERBACEOUS

Carex Sedges, Flatsedges, Panicgrass, Corn Salad, Virginia Wildrye, Ironweed, Venus' Looking-Glass, and Wild Onion

Photo 1. Evaluation site UPDEC 2. Photo taken facing south in August 2007.



Photo 2. Evaluation site UPDEC 3. Photo taken facing south in August 2007.

Evergreen Forest HEP Evaluation Sites



DOMINANT VEGETATION

TREES

Eastern Red Cedar, Red Oak,
and Post Oak

SHRUBS & VINES

Coral Berry, Greenbrier,
Gum Bumelia, and
Possumhaw Holly

HERBACEOUS

Cherokee Sedge, Panicgrass,
Johnsongrass, and
KR Bluestem

Photo 3. Evaluation site EF 3. Photo taken facing north in August 2007.



Photo 4. Evaluation site EF 1. Photo taken facing east in June 2007.

Tree Savanna HEP Evaluation Sites



DOMINANT VEGETATION

TREES

Cedar Elm, Bois d'Arc, and Eastern Red Cedar

SHRUBS & VINES

Gum Bumelia, Coralberry, Greenbrier, Poison Ivy, and Southern Dewberry

HERBACEOUS

Ironweed, Western Ragweed, Sedge, Flatsedge, Bermudagrass, Panicgrass, KR Bluestem, Indian Plantain, Prairie Plantain, Croton, and Dock.

Photo 5. Evaluation site TS 4. Photo taken facing east in August 2007.



Photo 6. Evaluation site TS 4. Photo taken facing north in August 2007.

Shrubland HEP Evaluation Sites



DOMINANT VEGETATION

IMMATURE TREES

Green Ash, Bois d'Arc, and
Eastern Red Cedar

SHRUBS & VINES

Honey Locust, Persimmon, and
Coralberry

HERBACEOUS

Cherokee Sedge, Goldenrod,
Johnsongrass, Silver Bluestem,
Wild Pea, and Snow-On-The-
Prairie

Photo 7. Evaluation site SH 5. Photo taken facing east in August 2007.



Photo 8. Evaluation site SH 5. Photo taken facing north in August 2007.

Cropland HEP Evaluation Sites



DOMINANT VEGETATION

PLANTED FIELDS

Oats, Soybeans, Hay, and
Winter Wheat

FALLOW FIELDS

Johnsongrass, Panicgrass,
Knotroot Bristlegrass, Tall
Fescue, Bermudagrass, Dock,
Pigweed, Spurge, Morning
Glory, and Black-Eyed Susan.

Photo 9. Evaluation site CROP 2. Photo taken facing east in August 2007.



Photo 10. Evaluation site CROP 2. Photo taken facing north in August 2007.

Grassland / Old Field HEP Evaluation Sites



DOMINANT VEGETATION

HERBACEOUS
Tall Fescue, Perennial Rye,
Bahia Grass, Bermudagrass,
Texas Wintergrass, Dallisgrass,
Western Ragweed, Ironweed,
Dock, Vetch, and Wild Pea

Photo 11. Evaluation site GOF 13. Photo taken facing north in August 2007.



Photo 12. Evaluation site GOF 16. Photo taken facing north in August 2007.

Riparian Woodland / Bottomland Hardwood HEP Evaluation Sites



DOMINANT VEGETATION

TREES

Black Willow, Boxelder, Green Ash, Sugarberry, and Cedar Elm

SHRUBS & VINES

Honey Locust, Poison Ivy, Coralberry, Buttonbush, and Virginia Creeper

HERBACEOUS

Baccharis, Cherokee Sedge, Ragweed, and Virginia Wildrye

Photo 13. Evaluation site RWBH 1. Photo taken facing north in July 2007.



Photo 14. Evaluation site RWBH 15. Photo taken facing south in August 2007.

Shrub Wetland HEP Evaluation Sites



DOMINANT VEGETATION

TREES

Green Ash, Sugarberry, and
Cedar Elm

SHRUBS & VINES

Honey Locust and Baccharis

HERBACEOUS

Sedges, Ragweed, Ironweed,
Goldenrod, Evening Primrose,
Round-Leaf Groundsel,
Trumpet Vine, and Wild Pea

Photo 15. Evaluation site SHWET 2. Photo taken facing north in July 2007.



Photo 16. Evaluation site SHWET 1. Photo taken facing west in August 2007.

Emergent / Herbaceous Wetland HEP Evaluation Sites



DOMINANT VEGETATION

HERBACEOUS
Rushes Blue Sedge, Spikerush,
Flatsedge, Smartweed,
Sumpweed, Frog Fruit, Water
Primrose, Balloon Vine, Dock,
Buttercup, Crowngrass, and
Eastern Gammagrass

Photo 17. Evaluation site EHW 3. Photo taken facing east in July 2007.



Photo 18. Evaluation site EHW 1. Photo taken facing north in July 2007.

APPENDIX K: HYDROGEOMORPHIC APPROACH (HGM) REPORT FOR THE PROPOSED LOWER BOIS D'ARC CREEK RESERVOIR SITE

K-1: Modifying the East Texas HGM for the Lower Bois d'Arc Creek Reservoir Project

K-2: Functional Assessment of Forested Wetlands at Lower Bois d'Arc Creek Reservoir Site using the Modified East Texas HGM

**Modifying the East Texas HGM for the Lower Bois D' Arc Creek Reservoir Project
Final Report**

Prepared by:

Amy Camp, Hans Williams, Amy Urbanovsky, Jason Grogan

Waters of East Texas Center,

Arthur Temple College of Forestry and Agriculture

Stephen F. Austin State University

Nacogdoches, TX 75962-6109

and

Elizabeth Murray

Research Biologist

Wetlands and Coastal Ecology Branch

Environmental Laboratory (CEERD-EE-W)

U.S. Army Engineer Research and Development Center

At San Francisco District

1455 Market St., San Francisco, CA 94103

Presented to:

U. S. Army Corps of Engineers, Tulsa District

Regulatory Office (CESWT-RO)

1645 S 101 E Ave.

Tulsa, OK 74128-4609



**STEPHEN F. AUSTIN
STATE UNIVERSITY**

NACOGDOCHES, TEXAS



July 2016

Contents

Introduction	3
Objectives	4
Methods	6
The Reference Domain	6
General Sample Locations in Reference Domain	6
Wetland Assessment Area and Plot Data Measurements.....	7
Use of 2011 Study Data	8
Field Data Summary and Recalibration of Spreadsheet Calculator	8
Results	9
Field Data and Variable Subindex Curves	9
Changes to Curves.....	10
Introduction of Flats Models	11
Literature Cited	13
Appendix	14
Figures	14
Sampling Locations	14
Original East Texas HGM Variable Curves	19
Modified Fannin County HGM Variable Curves	24
Tables	28
Site and Plot Information	28
Field Data	31
Species Grouping	42
Tree Count by Species	43
Calculations	54
Original East Texas FCI Models	54
Modified Fannin County Models	55
Modified Fannin County Flats Models	56
Adjusted Quality Index Calculation for V_{TCOMP}	57

Introduction

In 2011, The Waters of East Texas Center, Stephen F. Austin State University, Arthur Temple College of Forestry and Agriculture (SFASU) was contracted by the Office of Wetlands, Oceans, and Watersheds, U. S. Environmental Protection Agency (EPA), Dallas, TX to conduct field testing in Fannin County, TX, of the methods outlined in the *Regional Guidebook for Applying the Hydrogeomorphic Approach to the Functional Assessment of Forested Wetlands in Alluvial Valleys of East Texas* (Williams *et al.* 2010). This guidebook was developed to support forested wetland functional assessment in the modern floodplains of the riverine systems in the East Texas Pineywoods ecoregion. The objective for the 2011 study was to test the potential efficacy of the methods and models in the guidebook for use in assessing forested wetland functions for the proposed Lower Bois d' Arc Creek Reservoir (LBCR) Project (Dans and Williams 2011). Forested wetlands with riverine geomorphic locations in Fannin County thought to approach the highest functional condition were sampled to measure the wetland variables identified in the guidebook. Specific sample locations were determined by the availability of property access. The variables are used in models to calculate functional capacity indices (FCI). An a priori decision was made to use the mid-gradient riverine models in the guidebook. It was assumed that no adjustments to variable metrics would be necessary if the FCI equaled 1.0 (0 to 1.0 scale) for all mid-gradient riverine wetland functions assessed by the guidebook. It was anticipated that adjustments would be required to appropriately apply the guidebook to Fannin County due to metric differences for variables such as tree species composition, tree size, and forest stand structure. Based on the results from the limited number of sites sampled, the recommendation was that six variables required metric adjustments before the FCI models in the guidebook were suitable for use. These variables were tree basal area, thickness of the A horizon, composition of tallest woody vegetation stratum, tree composition, log biomass, and

woody debris biomass. Only the coarse woody debris variables were greatly different from what was observed in east Texas.

During the 2015 summer, SFASU was contacted by the U. S. Army Corps of Engineers, Tulsa District Regulatory Office (CESWT-RO) to discuss the additional work required to modify variable metrics and models in the East Texas HGM FCI spreadsheet calculator for use by the LBCR. The 2011 study was limited by the number of plots sampled. Although, the term “reference standard wetland” was used in the 2011 report, there was no planned intent to sample reference standard wetlands as defined by the HGM approach (Williams *et al.* 2010). Increased sampling of reference standard wetlands was required to improve necessary adjustments to variable metrics and increase user confidence for applying the East Texas HGM guidebook models outside of their intended geographic area. Also, after the SFASU team became more familiar with the geomorphic characteristics of the germane wetlands, it was determined that the low-gradient riverine models would be more appropriate for characterization of functional condition. CESWT-RO coordinated with SFASU to conduct additional field sampling during the fall 2015 and winter 2016 in reference standard low gradient riverine forested wetlands within a geographic area (HGM reference domain) representing conditions in Fannin County. The CESWT-RO coordinated with U. S. Army Corps of Engineers, Environmental Research and Development Center (ERDC) to use the field results to make variable metric and model modifications to the East Texas HGM low gradient riverine spreadsheet calculator for specific use by the LBCR.

Objectives

Developing a new, comprehensive HGM guidebook was not the intent of 2015-16 study. The overall goal of the 2015-16 study was to modify the existing East Texas HGM low-gradient riverine models and spreadsheet calculator as necessary for use by the LBCR. Since the

planning and development of an HGM approach should be directed by a team familiar with the reference domain ecology, an assessment team was formed to identify and guide the completion of the study objectives. The assessment team consisted of personnel from the organizations listed below.

- U. S. Army Corps of Engineers, Tulsa District Regulatory Office (CESWT-RO)
- U. S. Army Corps of Engineers, Environmental Research and Development Center (ERDC)
- U. S. Environmental Protection Agency (EPA)
- U. S. Fish and Wildlife Service (FWS)
- U. S. Forest Service (USFS)

- Texas Commission on Environmental Quality (TCEQ)
- Texas Parks and Wildlife Department (TP&W)
- Waters of East Texas Center, Stephen F. Austin State University (SFASU)

- Freese and Nichols, Inc.
- North Texas Municipal Water District (NTMWD)
- Solv LLC

The assessment team met on October 6, 2015 at the John Bunker Sands Wetlands Center, Seagoville, TX to review general HGM principles. On November 15, 2015 the assessment team met at the Pat Mayse Wildlife Management Area, Paris, TX to review HGM field methods and determine the study objectives. The objectives were:

1. Establish the reference domain for the LBCR study.
2. Determine general sampling locations within the reference domain that contained forested low-gradient riverine reference standard wetlands.
3. Conduct field data collection in the reference standard wetlands within the reference domain using East Texas HGM guidebook methodology.
4. Use the field data to support modifications to the East Texas HGM low gradient riverine spreadsheet calculator based on the adjusted variable metrics and FCI models.

Methods

The Reference Domain

The CESWT-RO presented to the assessment team the reference domain on October 15, 2015. The geographic extent of the reference domain was based on the U. S. Geological Survey Hydrologic Unit Codes (HUC) in and around Fannin County, TX (Appendix Figure 1, p. 15). The main ecoregions represented in the reference domain are Blackland Prairie and Post Oak Savannah (Gould *et al.* 1960). Sampling within the reference domain was done primarily in the low-gradient riverine geomorphic settings of EPA Level IV Ecoregions 32c and 33f in and around Fannin County, TX.

General Sample Locations in Reference Domain

The general geomorphic and vegetational characteristics of a reference standard wetland were discussed and agreed upon by the assessment team at the November 15, 2015 meeting. In general, a reference standard wetland, a wetland thought to exhibit the best condition for all ecological functions, was characterized as forested, mature, exhibiting gap-phase dynamics, and receiving overbank, headwater flooding from a river or stream. For an example of the reference standard wetlands sampled in this study, refer to Appendix Figures 2A-2D, pp. 16-17. Based on this discussion, six sites were recommended to have locations with reference standard wetlands (Appendix Figure 3, p. 18). The sites sampled in chronological order were:

- U. S. Forest Service, Caddo National Grasslands-Bois-D' Arc Unit
- U. S. Forest Service, Caddo National Grasslands-Ladonia Unit
- White Oak Wildlife Management Area, Texas Parks and Wildlife Department
- Cooper Wildlife Management Area, Texas Parks and Wildlife Department
- Pat Mayse Wildlife Management Area, Texas Parks and Wildlife Department
- Lennox Woods, The Nature Conservancy of Texas

Appendix Table 1, p. 28, summarizes the sampling date and number of sampling points at each site.

Wetland Assessment Area and Plot Data Measurements

Field data collection was done by SFASU personnel. On occasion, other members of the assessment team accompanied the SFASU team as observers. Field data collection occurred during December 2015 through February 2016. Except as noted below, the wetlands assessment area (WAA) and plot based variables were measured using methods described in the East Texas HGM guidebook (Williams *et al.* 2010). WAA variables were assessed in the general area that represented reference standard characteristics and areas that were mature but not yet experiencing gap regeneration. The plots were randomly located in the WAA. Individual plots in the WAA were separated by at least 150 feet. The number of plots sampled in the WAA were based on WAA size, time on location, accessibility due to overbank flooding, and, based on best professional judgement, whether the WAA was adequately characterized. Coordinate locations of sampling points are included in the summary Appendix Table 2A-F, pp. 28-30)

Several modifications to the field data collection were agreed upon by the assessment team at the November 15, 2015 meeting. The 2011 SFASU field team found the A horizon depth to be difficult to measure in determining the metrics for V_{AHOR} . The hydric soil series typically found in the modern floodplains of Fannin County is the Tinn clay, 0 to 1 percent slopes, frequently flooded (fine, smectitic, thermic, Typic Hapluderts) (NRCS 2013). The Tinn soil is characterized by an A horizon to a depth of 17 inches. Since V_{AHOR} is used in only one function model (Cycle Nutrients), the assessment team agreed to delete this variable from that model in the spreadsheet calculator. As a result, this variable was not assessed in the field. In order to ensure consistency in field measurements between field teams for log biomass (V_{LOG}) and woody debris biomass (V_{WD}), the assessment team agreed to a standard protocol. Instead of the north and south orientation for the 50-foot transects recommended in the guidebook, the transects would be oriented north and east in an effort to capture woody debris that may be

oriented parallel to the river/stream direction. Each 50-foot transect started at plot center. Small diameter woody debris (0.25 to 1-inch diameter) was counted at the 40-foot to 46-foot segment. Medium diameter woody debris (1 to 3-inches diameter) was counted on the 24-foot to 36-foot segment.

Use of 2011 Study Data

The 2011 study included field sampling in mature forest stands that may or may not have met the reference standard definition, as well as, younger forest stands (Dans and Williams 2011). Since all sampling in 2011 was done within the appropriate geographic and hydrogeomorphic setting, the decision was made between CESWT-RO, ERDC and SFASU to utilize the 2011 data to supplement the 2015-16 data in order to facilitate calibration of the variable metrics used in the models. Specifically, calibration requires a range of conditions by which a curve may be derived, and these younger stands provided midrange conditions on which to ground the curves.

Field Data Summary and Recalibration of Spreadsheet Calculator

For each site and each plot sampled at a site, the WAA and plot-based field data were entered in to the East Texas HGM low gradient riverine spreadsheet calculator for computation of the variable averages and the conversion of the results from English to metric units. These results are summarized in Appendix Tables 3A-3L, pp. 32-41. To facilitate recalibration of the East Texas HGM variable metrics, the SFASU field team characterized each plot using two criteria: maturity and climax stage. The maturity and climax categories are:

Maturity Ranking:

1. Over-mature
2. Mature
3. Younger

Climax Stage Ranking:

1. Mature climax structure. Single tree die-off and gap regeneration started.
2. Closed canopy of mature trees, no gap regeneration started, but anticipated based on tree maturity and density.
3. Closed canopy of young trees. Canopy thin enough that shrubs and ground cover plentiful.

The SFASU field team used forest stand structure characteristics and best professional judgement to assign each plot a maturity and climax stage ranking. The summary spreadsheets were sent to ERDC personnel for adjustment of the variable metrics and modification of the low-gradient riverine spreadsheet calculator.

To formulate the changes needed to accurately assess the LBCR data, the field data were organized by maturity, disturbance, and climax ranking. The reference standard was determined by grouping the data from the most mature sites. As reference standard data, most variables should be at or near 1.00. If the existing East Texas HGM variable subindex (VSI) curve for an individual variable captured the variability of the new data set, the original curve was kept. If the existing East Texas HGM VSI curve did not capture the variability of the reference standard LBCR data, the range for a 1.00 was expanded until it captured as many of those most mature sites as possible without also capturing a majority of less-mature sites. The steepness of the curves was then determined by looking at the other age classes, and trying to ensure stands of different maturities received different VSIs for the newly calibrated variables.

Results

Field Data and Variable Subindex Curves

Compilation of field data into the East Texas HGM calculator revealed that many variables already scored near a 1.00, implying that many variables required no change to the East Texas HGM VSI curves to make them applicable for the LBCR. A summary of the values found for each plot by site is included in the Appendix Tables 3-7, pp. 32-41. For those variables that were not consistently separating reference standard sites from the younger sites, new VSI curves were generated based on the field data. The original East Texas HGM VSI curves are included in Appendix Figures 4A-4R, pp. 19-23, and the revised LBCR HGM VSI curves are included in Appendix Figures 5A-5P, pp. 24-27.

The field dataset sent to ERDC (Appendix Tables 3-7, pp. 32-41) was the basis for any modifications of the East Texas HGM VSI curves. After calibration of the field data, it was determined that the following curves exhibited no change from the original East Texas HGM VSI curves:

- V_{PATCH}
- V_{FREQ}
- V_{DUR}
- V_{POND}
- V_{STRATA}
- V_{SOIL}
- V_{TBA}
- V_{TDEN}
- V_{SNAG}
- V_{OHOR}
- V_{GVC}
- V_{LITTER}

The East Texas HGM VSI curves that required modification are:

- V_{COMP}
- V_{SSD}
- V_{LOG}
- V_{WD}

All modifications to the East Texas curves were data-driven. If the field data variability was not adequately captured by the current East Texas VSI curve, it was adjusted to represent the values exhibited by the sampling sites ranked highest for both maturity and climax. The data from sites that ranked second and third for maturity and climax were used to adjust the steepness of the VSI curve on each side of the 1.00 range.

Changes to Curves

The metric range for a VSI score of 1.0 for V_{SSD} , V_{LOG} , and V_{WD} was larger for the LBCR data when compared with the East Texas VSI curves. This is supported by the data collected from the highest ranking sites. The East Texas HGM VSI curve for sapling-shrub density has a range from 1250 stems/ha to 2500 stems/ha. The LBCR sapling-shrub density VSI curve has a range from 1000 stems/ha to 4000 stems/ha. For log volume, the original East Texas range was from 8 m³/ha to 30 m³/ha, and the modified LBCR range is from 2.5 m³/ha to 60 m³/ha.

The range for woody debris originally was from 5 m³/ha to 35 m³/ha, and the modified range is from 20 m³/ha to 90 m³/ha.

The V_{TCOMP} species grouping and calculation was modified as well, based on field observations and regional literature. For each sampling plot, tree count was done by species to help support the development of the new species groupings. For example, the White Oak WMA site is situated between the Post Oak Savannah and Pineywoods ecoregions, and exhibits typical Pineywoods forest tree species composition. In addition to adjusting the species groupings, an adjusted quality index calculation was added to give value to diversity and better evaluate the variable. The modifications to the tree species grouping are listed in Appendix Table 8, p. 42, the tree count by species at each site is in Appendix Table 9A-F, pp. 43-53, and the calculation for the adjusted quality index is listed in the Appendix under Calculations, p. 57.

The East Texas HGM low-gradient riverine FCI equations were unchanged, with the exception of the removal of V_{AHOR} from the cycle nutrients function (Appendix pp. 51 and 52).

Introduction of Flats Models

At the May 4th, 2016, assessment team meeting, it was determined that a portion of the proposed Riverby Ranch mitigation site, Fannin County, TX, is functioning as a wetland in a flat geomorphic setting. This is due to an upstream dam (Denison Dam impounding Lake Texoma) on the Red River that flows adjacent to the mitigation site. In order for the LBCR HGM VSI curves to be used in the flat wetlands, adjustments were made to the low-gradient riverine models to indicate that these areas are functioning as flats (wetlands that are supported primarily by precipitation rather than riverine flooding). The models were altered by removing V_{FREQ} and V_{DUR} , in keeping with flats models in other HGM guidebooks. As with other HGM guidebooks, flat wetlands are not assessed for “Detain Floodwater” or “Export Organic Carbon,” as those functions require a closer tie to the river itself. The formulas for “Maintain Plant Communities” and “Provide Habitat for Fish and Wildlife” were revised to remove V_{FREQ} and

V_{DUR} . The remaining two FCI models (“Cycle Nutrients” and “Detain Precipitation”) are unchanged from the riverine form to flats form (See Appendix p. 53).

Discussion

It is important to note that the reference domain endured severe drought in 2011, as well as, an ice storm in December 2013. In the winter of 2015 and spring of 2016, the region experienced excessive rainfall leading to abnormal amounts of overbank flooding. The drought most likely killed many trees, potentially affecting the forest stand structure and many HGM variables, such as tree density, snag density, log volume, and/or woody debris variables. In addition, the increase in the size and number of canopy gaps may have contributed to increased sapling-shrub densities in the understory. The recent, high-energy flooding also had a large effect on the depth of the O horizon, litter cover, log volume, and woody debris. The O horizon was scoured on most sampling sites. At many sites the woody debris was concentrated in large drift piles due to the excessive flooding.

The majority of sampling was performed in the winter, not the growing season. This made tree species identification and variables such as ground vegetation cover potentially more difficult to determine. The climatic events mentioned above do occur on a regular basis in the reference domain, however, the assessment team is experienced in HGM field data collection and is confident the variables have been adequately assessed for this study.

Literature Cited

Dans, D. and Williams H. 2011. Field Testing East Texas HGM Riverine Wetland Functional Assessment Guidebook: Proposed Lower Bois d' Arc Creek Impoundment Project. Report Prepared by Waters of East Texas Center, Stephen F. Austin State University, Nacogdoches, TX. Report Submitted to Wetlands Division, Office of Wetlands, Oceans, and Watersheds, Environmental Protection Agency, Region 6, Dallas, TX in May 2011. 63 pp.

Gould, F. W., Hoffman, G. O. and Rechenthin, C. A. 1960. Vegetational areas of Texas. Texas A and M University, Texas Agricultural Experiment Station, Leaflet No. 492.

NRCS. 2013. Natural Resources Conservation Service, Web Soil Survey. <http://websoilsurvey.sc.egov.usda.gov/App/HomePage.htm>. Accessed June 10, 2016.

Williams, H. M., Miller, A. J., McNamee, R.S., and Klimas, C.V. (2010). "A Regional Guidebook for Applying the Hydrogeomorphic Approach to the Functional Assessment of Forested Wetlands in Alluvial Valleys of East Texas," ERDC/EL TR-10-17, U. S. Army Engineer Research and Development Center, Vicksburg, MS.

Appendix

Figures

Sampling Locations

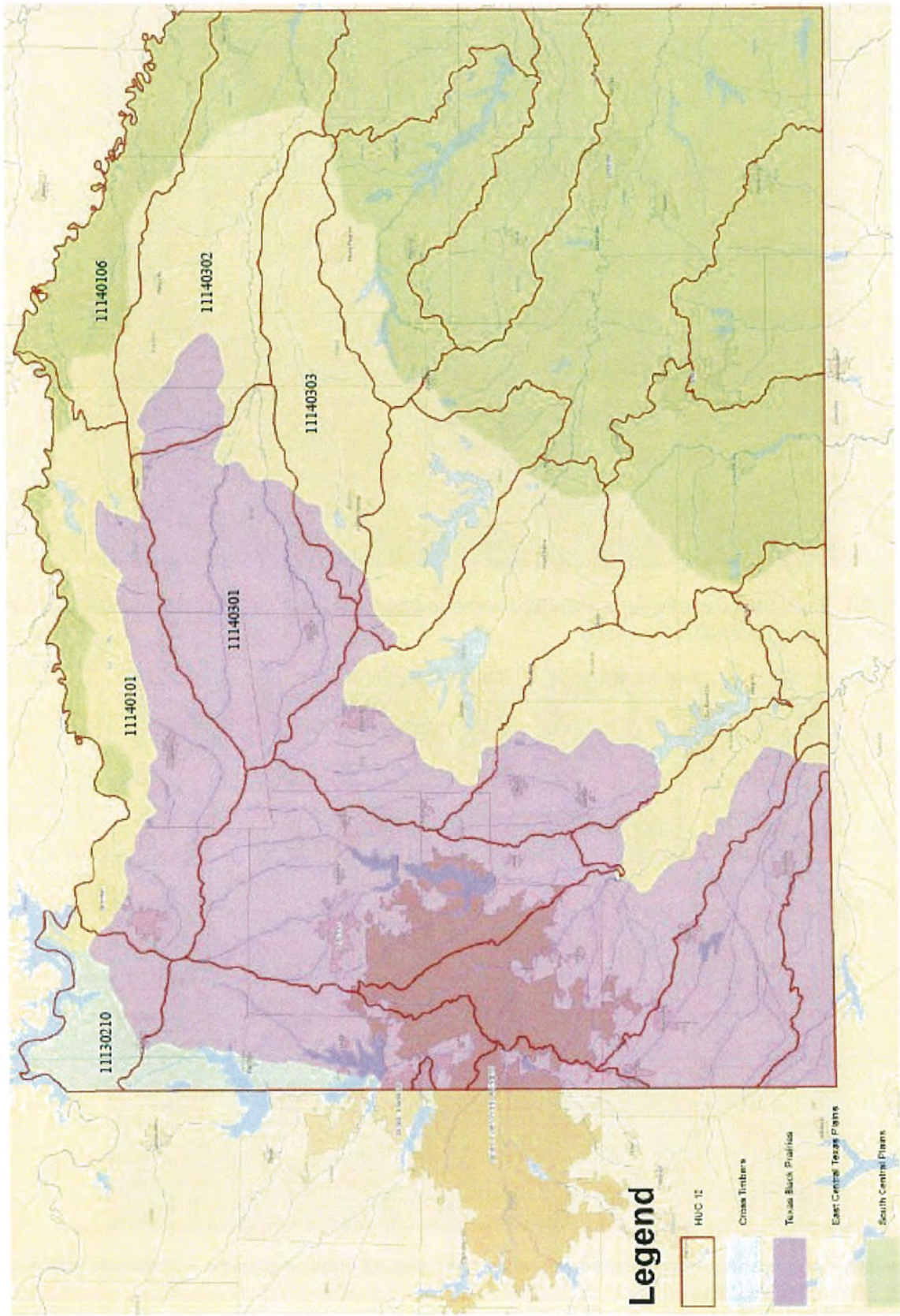

Figure 1. Reference domain in Northeast Texas chosen for the LBCR study including hydrologic unit codes (HUC).



Figure 2A. Example of a reference standard wetland site for Fannin County. Photo was taken at Plot 9 on Pat Mayse WMA.



Figure 2B. Example of a reference standard wetland site for Fannin County. Photo was taken at Plot 10 on Pat Mayse WMA.



Figure 2C. Example of a reference standard wetland site for Fannin County. Photo was taken at Plot 16 on Pat Mayse WMA.



Figure 2D. Example of a reference standard wetland site for Fannin County. Photo was taken at Plot 2 on Pat Mayse WMA.

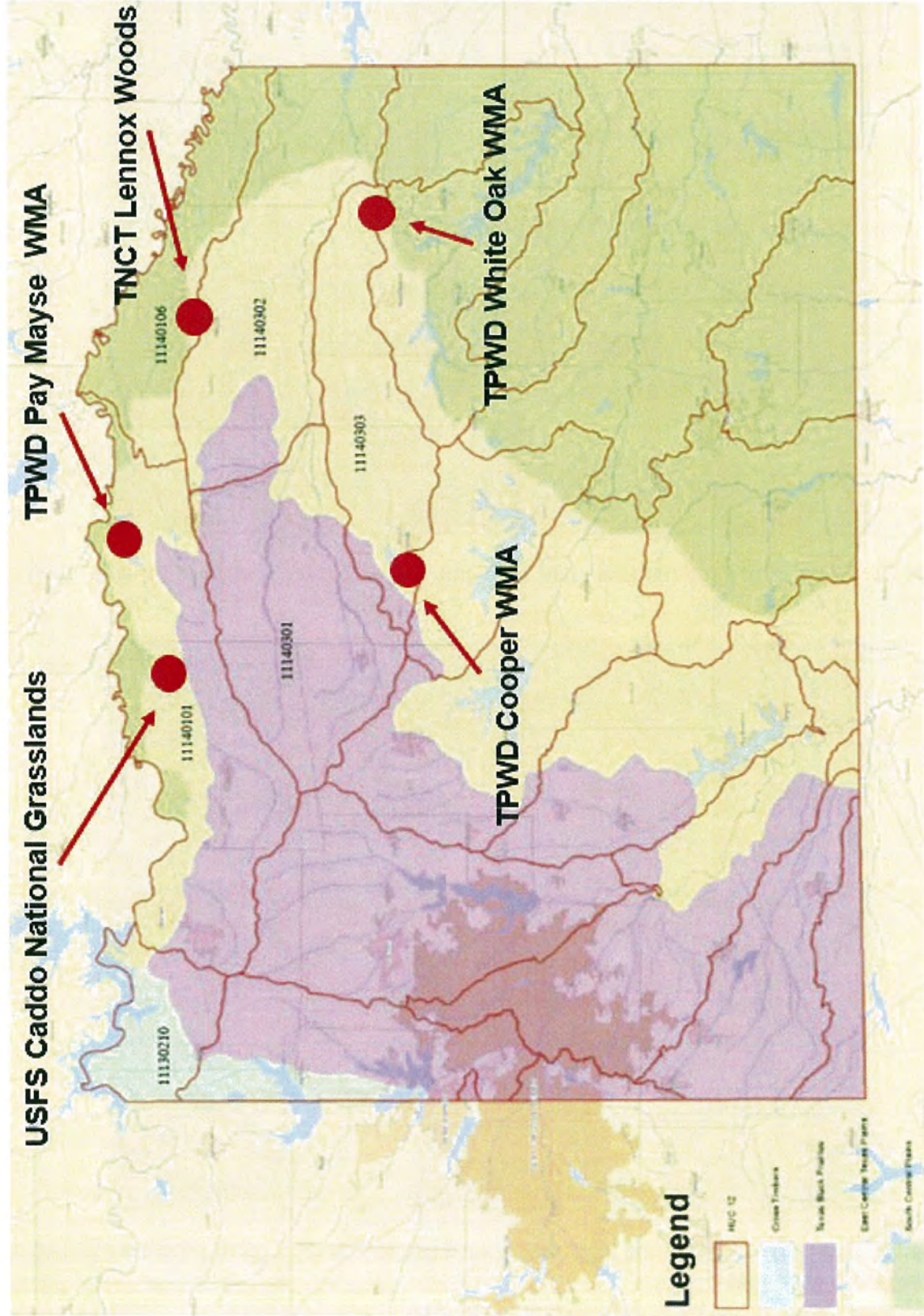

Figure 3. Locations of the six LBCR sampling sites within the reference domain in Fannin County, TX.

Original East Texas HGM Variable Curves

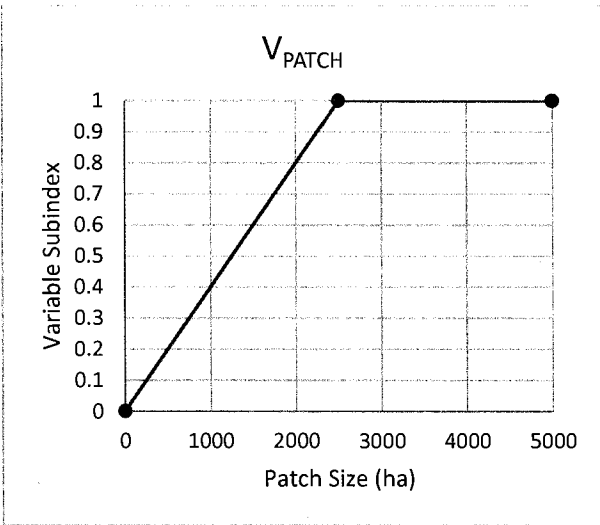

Figure 4A. Original East Texas VSI curve for patch size.

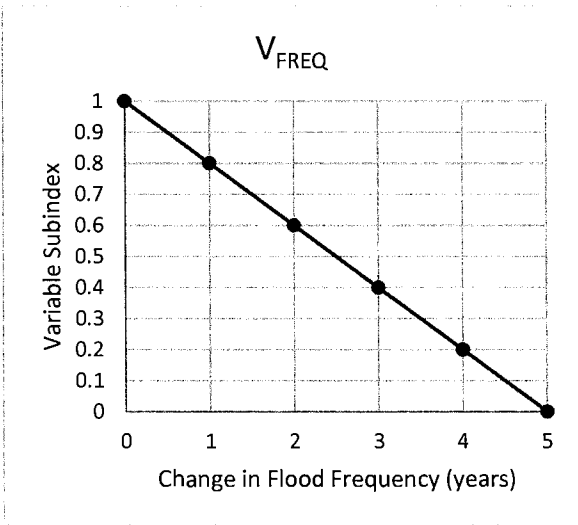

Figure 4B. Original East Texas VSI curve for flood frequency interval.

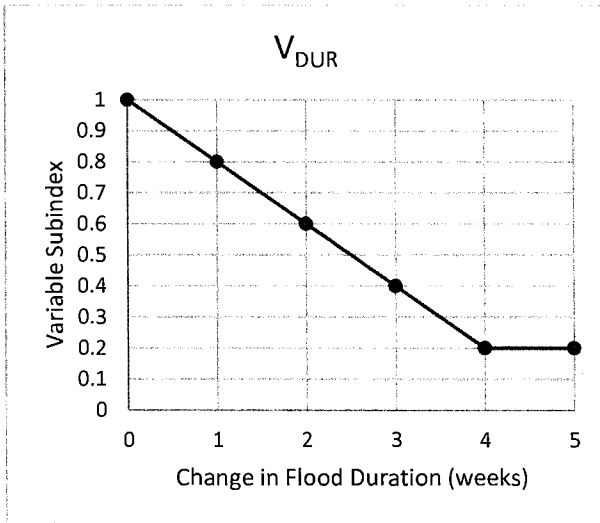

Figure 4C. Original East Texas VSI curve for flood duration.

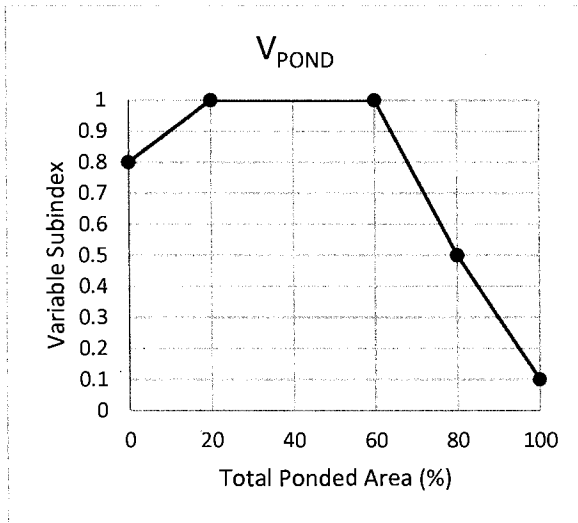

Figure 4D. Original East Texas VSI curve for percent ponding.

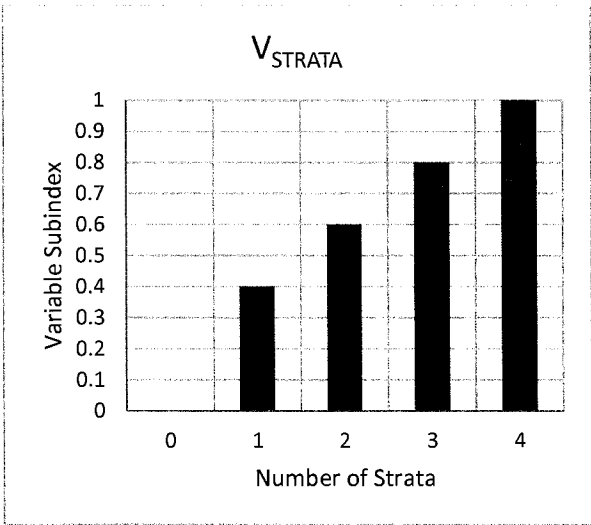

Figure 4E. Original East Texas VSI curve for number of vegetative strata present.

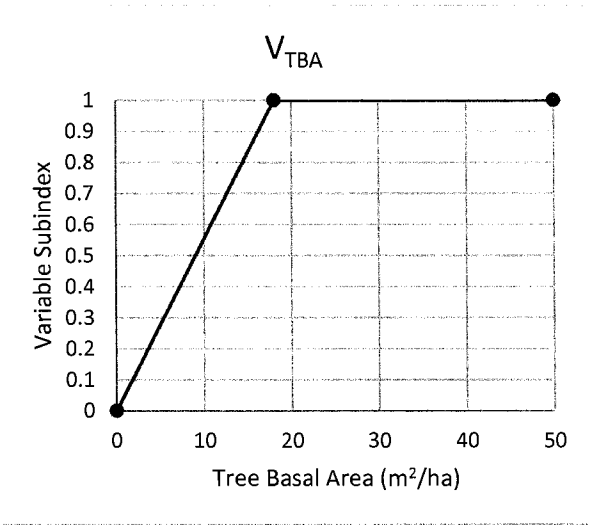

Figure 4F. Original East Texas VSI curve for basal area.

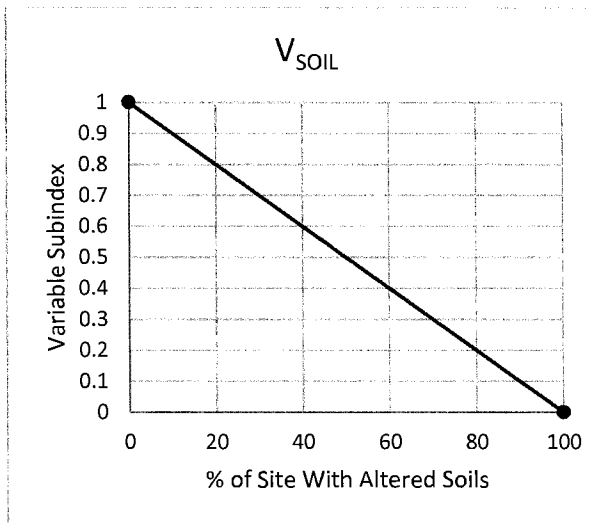

Figure 4G. Original East Texas VSI curve for percent altered soils.

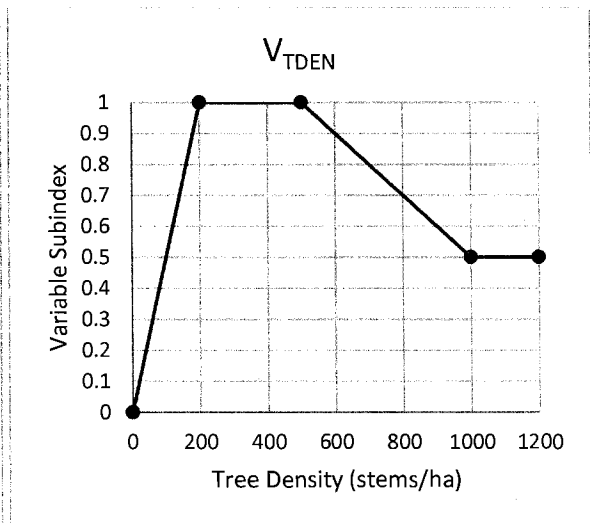

Figure 4H. Original East Texas VSI curve for tree density.

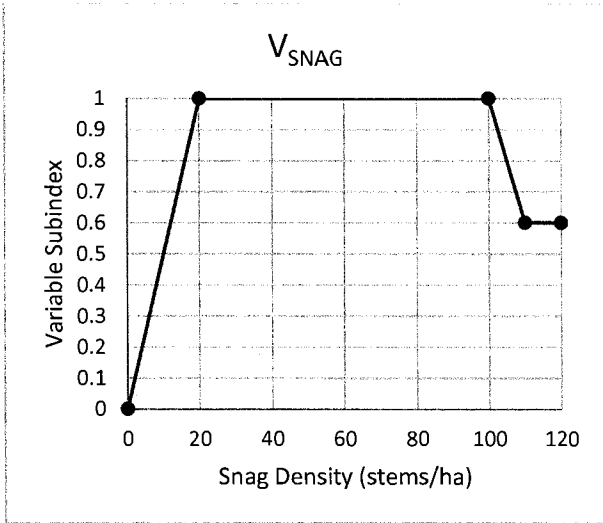

Figure 4I. Original East Texas VSI curve for snag density.

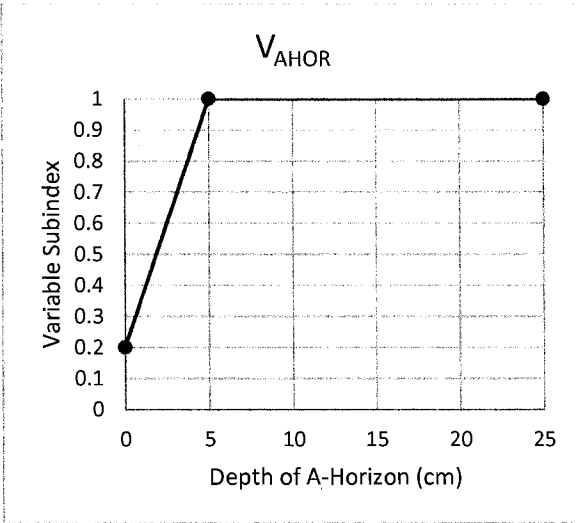

Figure 4J. Original East Texas VSI curve for A horizon depth.

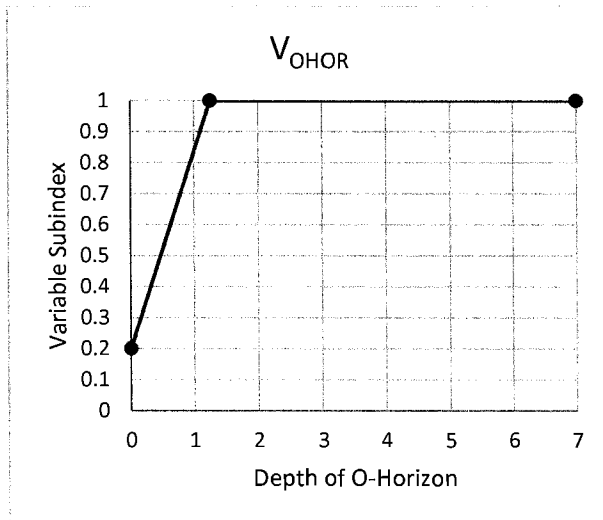

Figure 4K. Original East Texas VSI curve for O horizon depth.

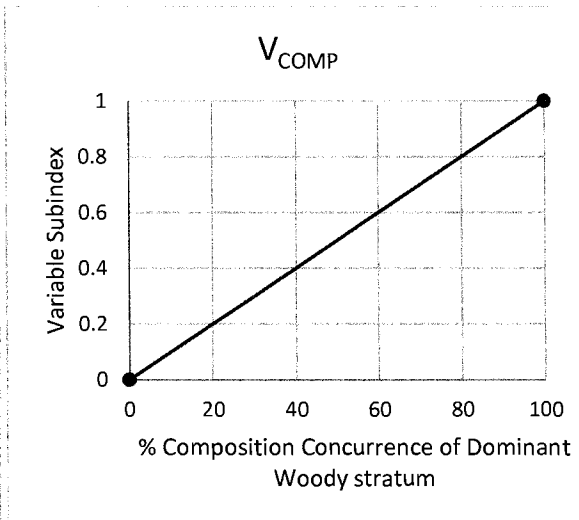

Figure 4L. Original East Texas VSI curve for percent composition of dominant woody stratum.

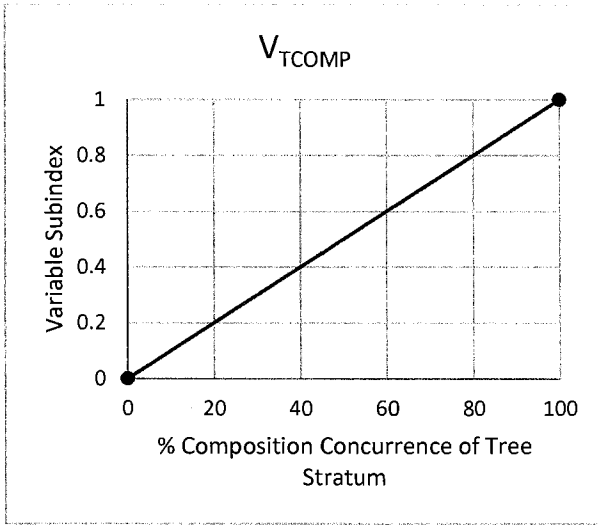

Figure 4M. Original East Texas VSI curve for percent composition of tree stratum.

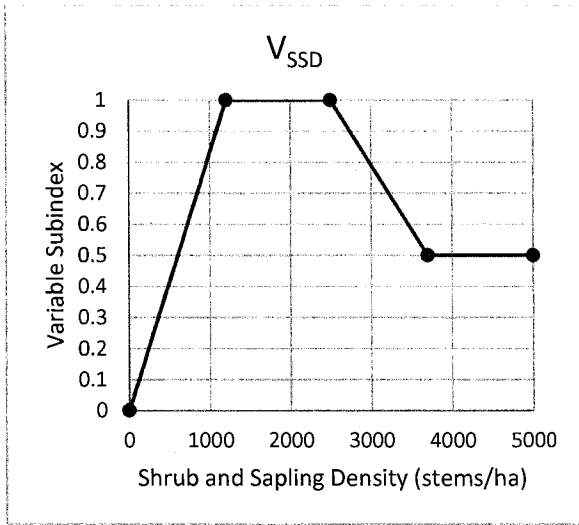

Figure 4N. Original East Texas VSI curve for shrub and sapling density.

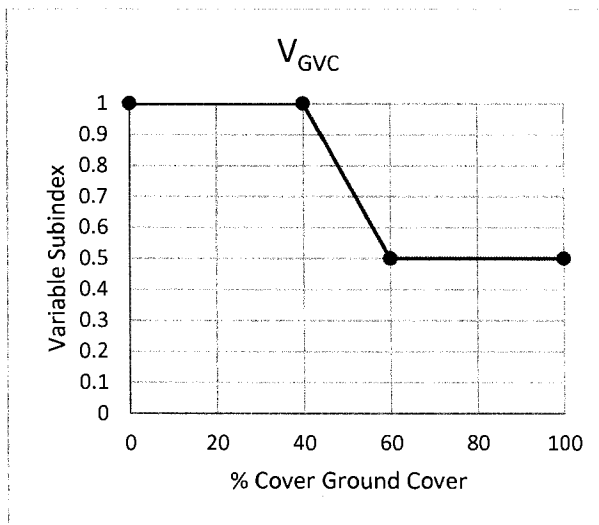

Figure 4O. Original East Texas VSI curve for percent ground cover.

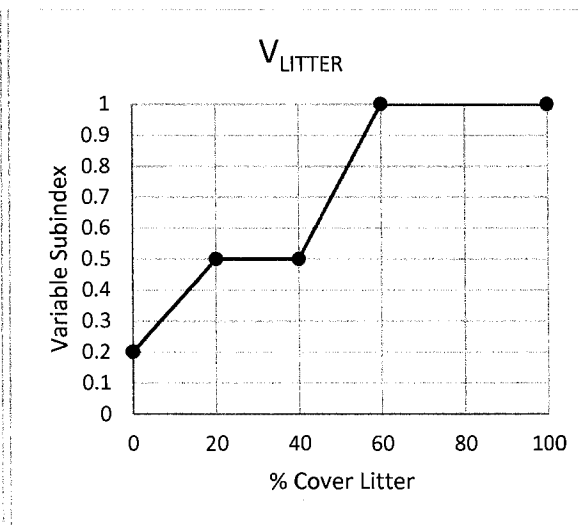

Figure 4P. Original East Texas VSI curve for percent litter cover.

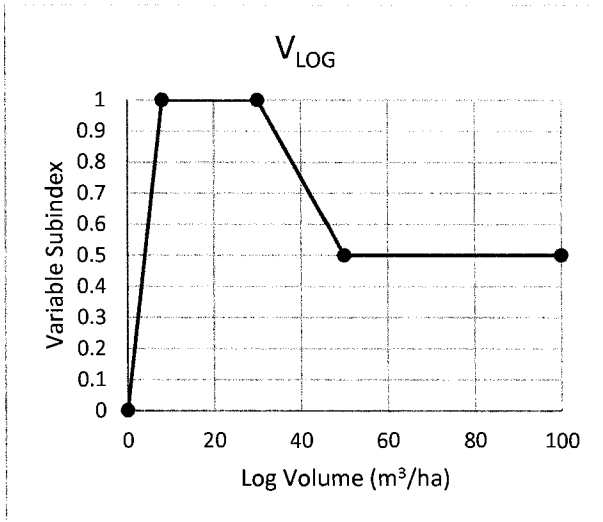

Figure 4Q. Original East Texas VSI curve for log volume.

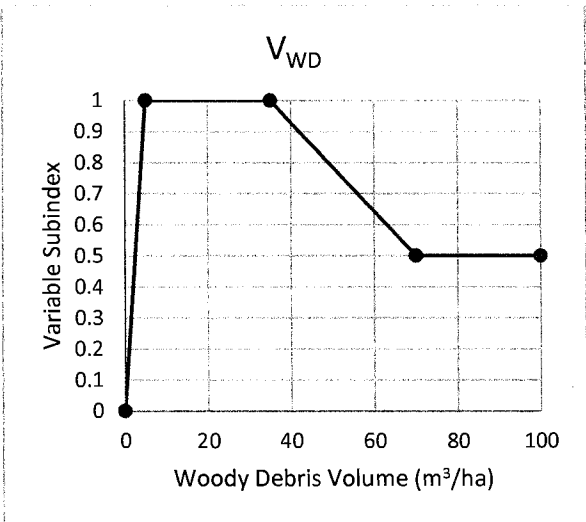

Figure 4R. Original East Texas VSI curve for woody debris volume.

Modified Fannin County HGM Variable Curves

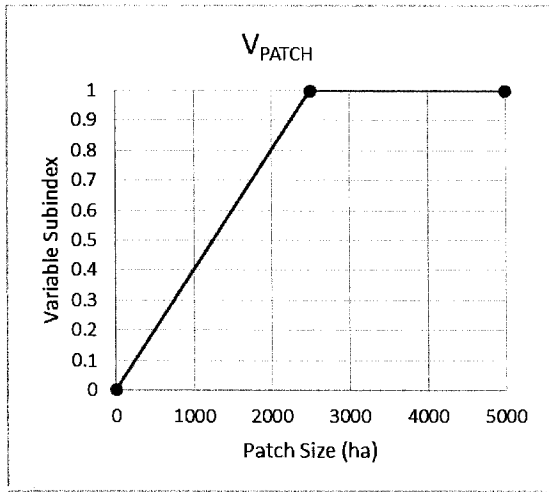

Figure 5A. Modified Fannin County VSI curve for patch size.

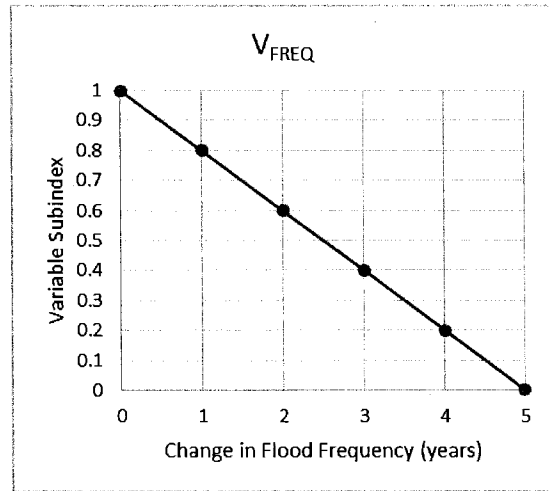

Figure 5B. Modified Fannin County VSI curve for flood frequency.

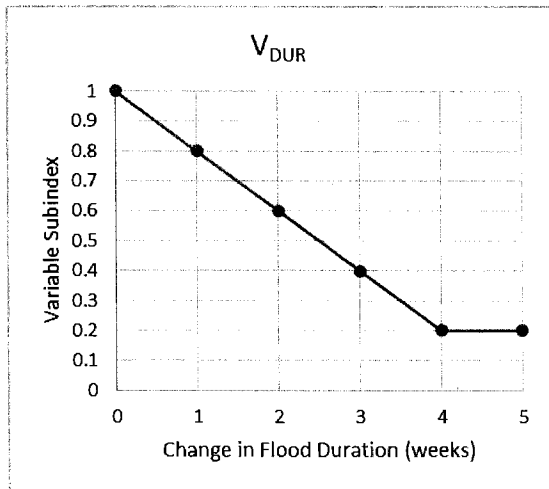

Figure 5C. Modified Fannin County VSI curve for flood duration.

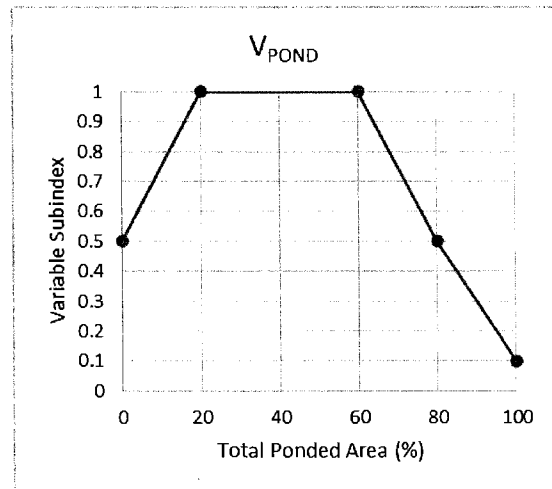

Figure 5D. Modified Fannin County VSI curve for percent ponded area.

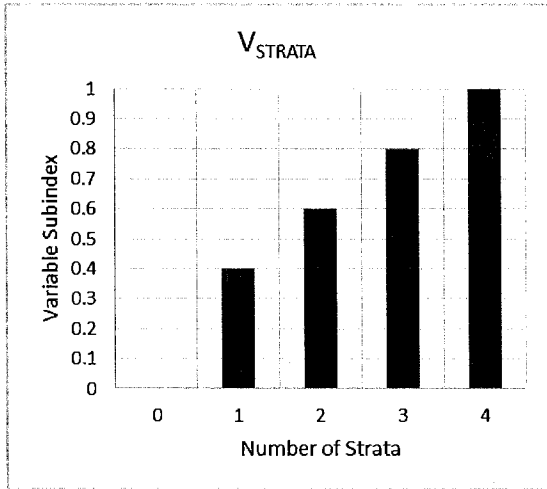

Figure 5E. Modified Fannin County VSI curve for number of strata present.

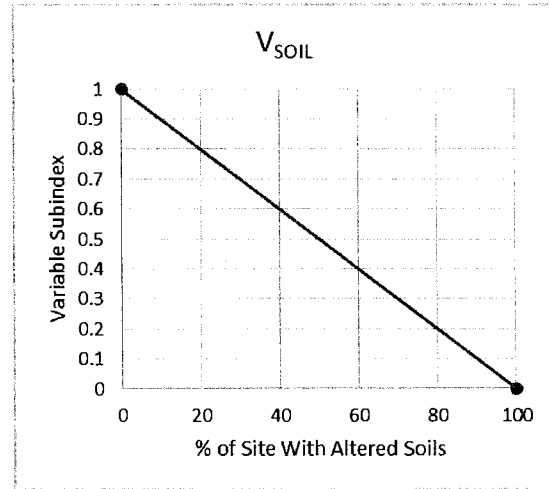

Figure 5F. Modified Fannin County VSI curve for percent altered soils.

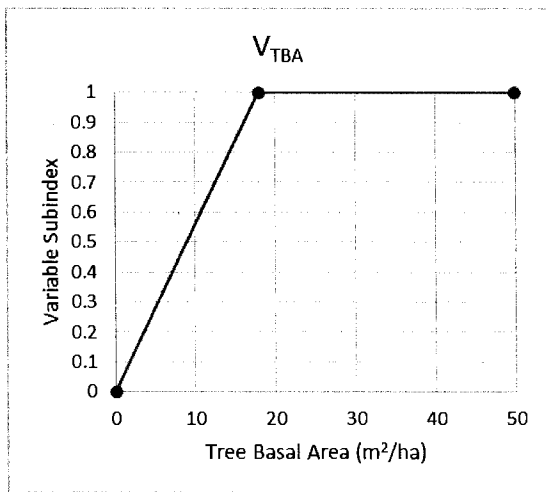

Figure 5G. Modified Fannin County VSI curve for basal area.

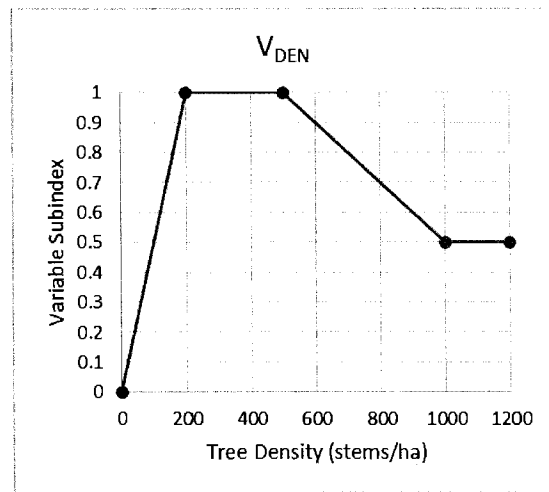

Figure 5H. Modified Fannin County VSI curve for tree density.

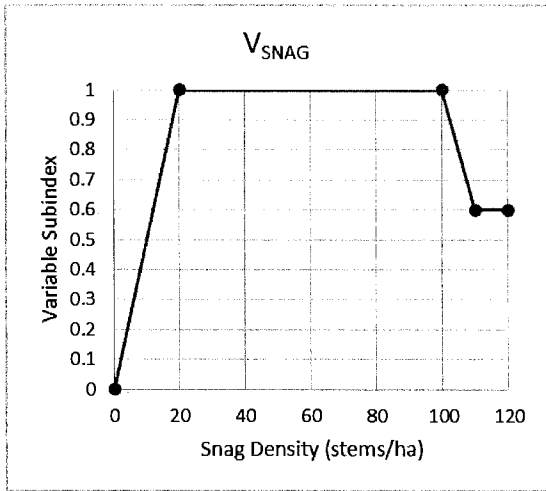

Figure 5I. Modified Fannin County VSI curve for snag density.

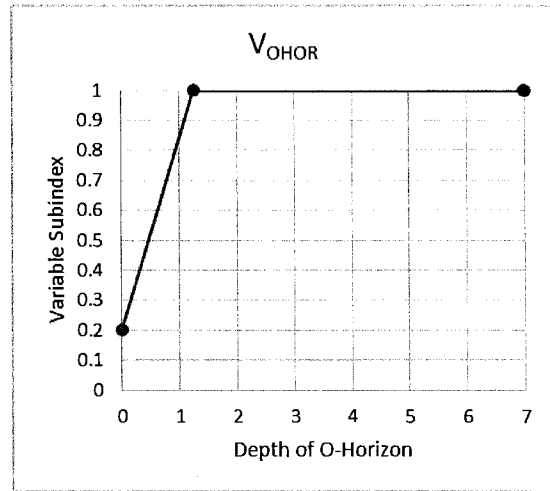

Figure 5J. Modified Fannin County VSI curve for O horizon depth.

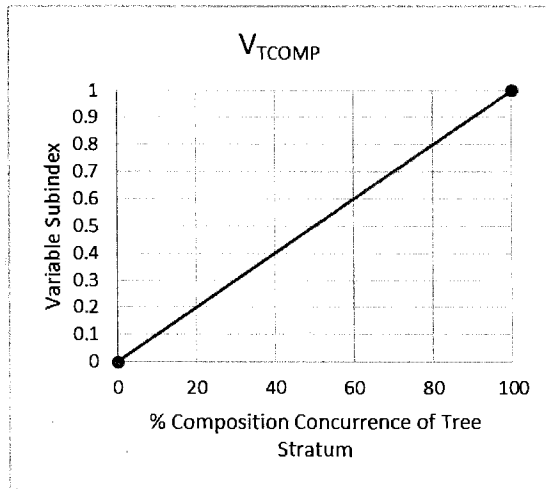

Figure 5K. Modified Fannin County VSI curve for tree composition.

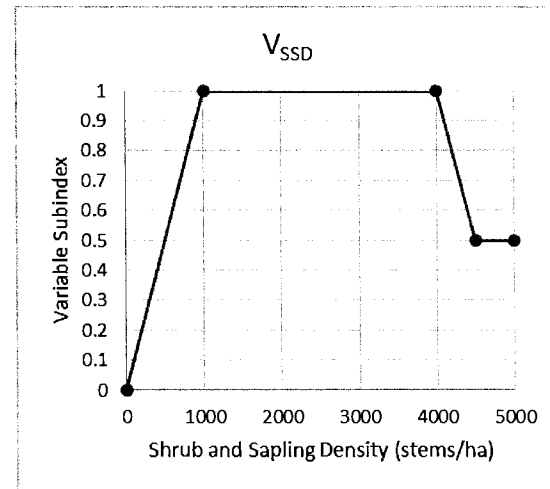

Figure 5L. Modified Fannin County VSI curve for shrub and sapling density.

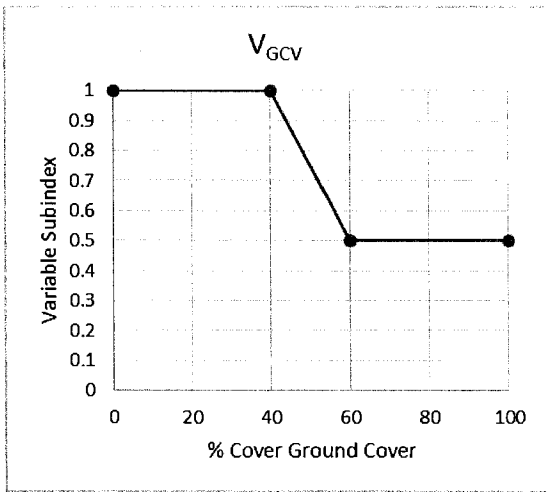

Figure 5M. Modified Fannin County VSI curve for percent ground cover.

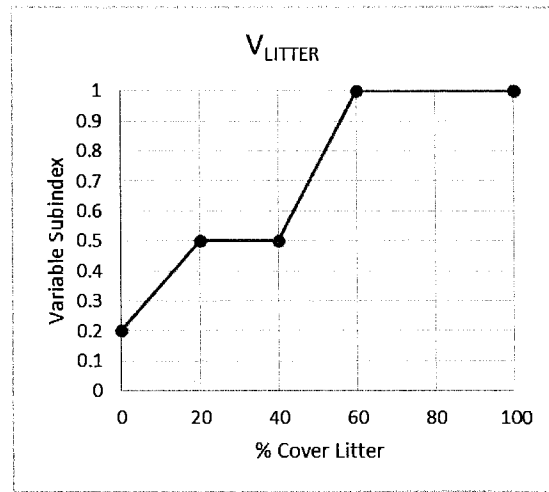

Figure 5N. Modified Fannin County VSI curve for percent litter cover.

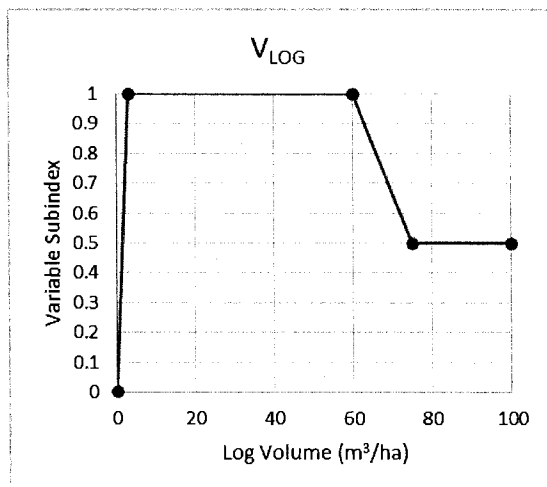

Figure 5O. Modified Fannin County VSI curve for log volume.

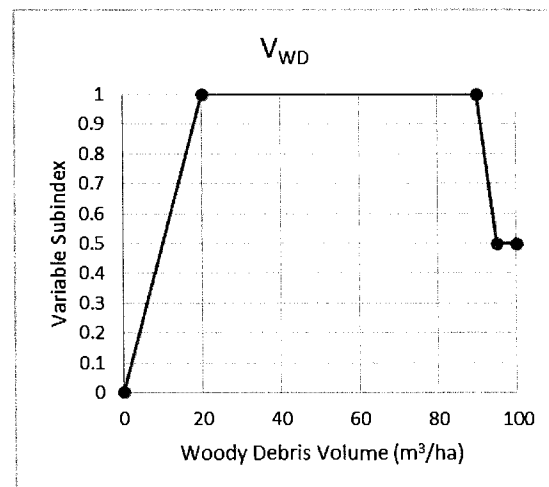

Figure 5P. Modified Fannin County VSI curve for woody debris volume.

Tables

Site and Plot Information

Table 1. Summary of sampling dates and number of sampling points at each sampling location for the LBCR study.

Sampling Location	Date Sampled	Number of Sampling Points
Caddo National Grasslands – Bois D’Arc Unit	12/09/15 – 12/10/15	14
Caddo National Grasslands – Ladonia Unit	12/16/15	4
Pat Mayse WMA	02/04/16 – 02/05/16	17
White Oak WMA	01/28/16 & 02/19/16	15
Cooper WMA	01/29/16	6
TNC Lennox Woods	02/18/16	8

Table 2A. Coordinate locations of all LBCR sampling points for the Caddo National Grasslands Bois D’Arc Unit.

Study Site	Latitude	Longitude
USFS Caddo National Grass Lands Bois D’Arc Unit Plot 1	33.7433453	-95.95981038
USFS Caddo National Grass Lands Bois D’Arc Unit Plot 2	33.74268982	-95.95942287
USFS Caddo National Grass Lands Bois D’Arc Unit Plot 3	33.74166458	-95.95996705
USFS Caddo National Grass Lands Bois D’Arc Unit Plot 4	33.74089807	-95.96033462
USFS Caddo National Grass Lands Bois D’Arc Unit Plot 5	33.7407826	-95.95970883
USFS Caddo National Grass Lands Bois D’Arc Unit Plot 6	33.7453938	-95.96204465
USFS Caddo National Grass Lands Bois D’Arc Unit Plot 7	33.7449488	-95.96302773
USFS Caddo National Grass Lands Bois D’Arc Unit Plot 8	33.74654137	-95.96114155
USFS Caddo National Grass Lands Bois D’Arc Unit Plot 9	33.74338332	-95.96279998
USFS Caddo National Grass Lands Bois D’Arc Unit Plot 10	33.74255005	-95.96283647
USFS Caddo National Grass Lands Bois D’Arc Unit Plot 11	33.74187108	-95.96351153
USFS Caddo National Grass Lands Bois D’Arc Unit Plot 12	33.741823	-95.96410965
USFS Caddo National Grass Lands Bois D’Arc Unit Plot 13	33.74057737	-95.9626368
USFS Caddo National Grass Lands Bois D’Arc Unit Plot 14	33.74103135	-95.9636242

Table 2B. Coordinate locations of all LBCR sampling points for the Caddo National Grasslands Ladonia Unit.

Study Site	Latitude	Longitude
USFS Caddo National Grass Lands Ladonia Unit Plot 1	33.79768538	-95.8816987
USFS Caddo National Grass Lands Ladonia Unit Plot 2	33.79471243	-95.8834426
USFS Caddo National Grass Lands Ladonia Unit Plot 3	33.79434773	-95.88237828
USFS Caddo National Grass Lands Ladonia Unit Plot 4	33.79248402	-95.88337712

Table 2C. Coordinate locations of all LBCR sampling points for White Oak WMA.

Study Site	Latitude	Longitude
TPWD White Oak WMA Plot 1	33.30036275	-94.8232002
TPWD White Oak WMA Plot 2	33.30063995	-94.82366545
TPWD White Oak WMA Plot 3	33.3009408	-94.82429165
TPWD White Oak WMA Plot 4	33.30084133	-94.82494255
TPWD White Oak WMA Plot 5	33.30056635	-94.8255382
TPWD White Oak WMA Plot 6	33.30031772	-94.82603038
TPWD White Oak WMA Plot 7	33.30161257	-94.8252346
TPWD White Oak WMA Plot 8	33.302209	-94.82547813
TPWD White Oak WMA Plot 9	33.30276123	-94.82571237
TPWD White Oak WMA Plot 10	33.303353	-94.82596847
TPWD White Oak WMA Plot 11	33.30433932	-94.82630405
TPWD White Oak WMA Plot 12	33.27584697	-94.74037952
TPWD White Oak WMA Plot 13	33.27623525	-94.73964307
TPWD White Oak WMA Plot 14	33.27585712	-94.73933983
TPWD White Oak WMA Plot 15	33.27585958	-94.7387917

Table 2D. Coordinate locations of all LBCR sampling points for Cooper WMA.

Study Site	Latitude	Longitude
TPWD Cooper WMA Plot 1	33.25280033	-95.79501742
TPWD Cooper WMA Plot 2	33.25309992	-95.79486032
TPWD Cooper WMA Plot 3	33.25360307	-95.79484568
TPWD Cooper WMA Plot 4	33.25386913	-95.79430807
TPWD Cooper WMA Plot 5	33.25418463	-95.79448687
TPWD Cooper WMA Plot 6	33.25410905	-95.79510808

Table 2E. Coordinate locations of all LBCR sampling points for Pat Mayse WMA.

Study Site	Latitude	Longitude
TPWD Pat Mayse WMA Plot 1	33.7944777	-95.67430932
TPWD Pat Mayse WMA Plot 2	33.79464307	-95.67362865
TPWD Pat Mayse WMA Plot 3	33.79462212	-95.67297182
TPWD Pat Mayse WMA Plot 4	33.79521733	-95.67297582
TPWD Pat Mayse WMA Plot 5	33.79497623	-95.67419137
TPWD Pat Mayse WMA Plot 6	33.79554135	-95.67652143
TPWD Pat Mayse WMA Plot 7	33.79592177	-95.6770445
TPWD Pat Mayse WMA Plot 8	33.79645008	-95.67747633
TPWD Pat Mayse WMA Plot 9	33.79658295	-95.67828087
TPWD Pat Mayse WMA Plot 10	33.7932427	-95.67358313
TPWD Pat Mayse WMA Plot 11	33.7927972	-95.67292987
TPWD Pat Mayse WMA Plot 12	33.7932318	-95.67271698
TPWD Pat Mayse WMA Plot 13	33.79321555	-95.67177645
TPWD Pat Mayse WMA Plot 14	33.78944873	-95.67233893
TPWD Pat Mayse WMA Plot 15	33.7890028	-95.67289952
TPWD Pat Mayse WMA Plot 16	33.78876557	-95.67407875
TPWD Pat Mayse WMA Plot 17	33.78765152	-95.67432448

Table 2F. Coordinate locations of all LBCR sampling points for Lennox Woods.

Study Site	Latitude	Longitude
TNCT Lennox Woods Plot 1	33.73554007	-95.08355218
TNCT Lennox Woods Plot 2	33.7358862	-95.0846221
TNCT Lennox Woods Plot 3	33.73578458	-95.08567867
TNCT Lennox Woods Plot 4	33.73525033	-95.08514368
TNCT Lennox Woods Plot 5	33.73472332	-95.08529805
TNCT Lennox Woods Plot 6	33.73440662	-95.0849352
TNCT Lennox Woods Plot 7	33.73427472	-95.0840929
TNCT Lennox Woods Plot 8	33.73518888	-95.08379133

Field Data

Table 3A. Field data collected for the LBCR study at the Caddo National Grasslands Bois D'Arc Unit.

Variable	Plot 1	Plot 2	Plot 3	Plot 4	Plot 5	Plot 6	Plot 7	Plot 8	Plot 9	Plot 10	Plot 11	Plot 12	Plot 13	Plot 14
A Maturity (1-3)	2	2	2	3	2	2	2	2	2	2	2	2	2	2
B Climax (1-3)	2	2	2	3	2	2	2	2	2	2	2	2	2	2
C Disturbance (1)	1	1	1	1	1	1	1	1	1	1	1	1	1	1
D Notes														
1 V _{PATCH}	2500	2500	2500	2500	2500	2500	2500	2500	2500	2500	2500	2500	2500	2500
2 V _{BUF30}	N/A	N/A	N/A	N/A	N/A	N/A	N/A	N/A	N/A	N/A	N/A	N/A	N/A	N/A
3 V _{BUF250}	N/A	N/A	N/A	N/A	N/A	N/A	N/A	N/A	N/A	N/A	N/A	N/A	N/A	N/A
4 V _{FREQ}	0	0	0	0	0	0	0	0	0	0	0	0	0	0
5 V _{DUR}	0	0	0	0	0	0	0	0	0	0	0	0	0	0
6 V _{POND}	50	50	50	50	50	50	50	50	50	50	50	50	50	50
7 V _{STRATA}	3	3	3	3	3	3	3	3	3	3	3	3	3	3
8 V _{SOIL}	0	0	0	0	0	0	0	0	0	0	0	0	0	0
9 V _{TBA}	30	28	41	35	39	28	*	23	35	23	23	39	32	21
10 V _{TDEN}	600	650	825	550	775	500	750	325	450	625	425	750	400	325
11 V _{SNAG}	50	100	100	75	75	25	50	75	225	175	125	0	150	175
12 V _{OHOR}	0	0	0	0	0	0	0	0	0	0	0	0	0	0
13 V _{AHOR}	N/A*	N/A*	N/A*	N/A*	N/A*	N/A*	N/A*	N/A*	N/A*	N/A*	N/A*	N/A*	N/A*	N/A*
14 V _{GOMP}	N/A	N/A	N/A	N/A	N/A	N/A	N/A	N/A	N/A	N/A	N/A	N/A	N/A	N/A
15 V _{TCOMP}	66	66	66	75	66	66	66	66	66	66	66	66	66	66
16 V _{SSD}	0	250	250	3000	1000	125	250	125	125	125	375	250	125	1000
17 V _{GVC}	21	29	11	11	9	39	8	49	15	23	21	15	8	26
18 V _{LITTER}	20	51	19	89	69	45	18	15	18	36	50	23	20	89
19 V _{LOG}	3	9	17	22	5	0	10	31	17	6	2	0	3	11
20 V _{WD}	23	35	39	22	35	21	10	49	45	15	7	13	10	37

Table 3B. Variable subindex scores for field data collected for the LBCR study at the Caddo National Grasslands Bois D'Arc Unit.

Variable	Plot 1	Plot 2	Plot 3	Plot 4	Plot 5	Plot 6	Plot 7	Plot 8	Plot 9	Plot 10	Plot 11	Plot 12	Plot 13	Plot 14
1 V _{PATCH}	1.00	1.00	1.00	1.00	1.00	1.00	1.00	1.00	1.00	1.00	1.00	1.00	1.00	1.00
2 V _{BUF30}	N/A	N/A	N/A	N/A	N/A	N/A	N/A	N/A	N/A	N/A	N/A	N/A	N/A	N/A
3 V _{BUF250}	N/A	N/A	N/A	N/A	N/A	N/A	N/A	N/A	N/A	N/A	N/A	N/A	N/A	N/A
4 V _{FREQ}	1.00	1.00	1.00	1.00	1.00	1.00	1.00	1.00	1.00	1.00	1.00	1.00	1.00	1.00
5 V _{DUR}	1.00	1.00	1.00	1.00	1.00	1.00	1.00	1.00	1.00	1.00	1.00	1.00	1.00	1.00
6 V _{POND}	1.00	1.00	1.00	1.00	1.00	1.00	1.00	1.00	1.00	1.00	1.00	1.00	1.00	1.00
7 V _{STRATA}	0.80	0.80	0.80	0.80	0.80	0.80	0.80	0.80	0.80	0.80	0.80	0.80	0.80	0.80
8 V _{SOIL}	1.00	1.00	1.00	1.00	1.00	1.00	1.00	1.00	1.00	1.00	1.00	1.00	1.00	1.00
9 V _{TBA}	1.00	1.00	1.00	1.00	1.00	1.00	N/A	1.00	1.00	1.00	1.00	1.00	1.00	1.00
10 V _{TDEN}	0.90	0.85	0.68	0.95	0.73	1.00	0.75	1.00	1.00	0.88	1.00	0.75	1.00	1.00
11 V _{SNAG}	1.00	1.00	1.00	1.00	1.00	1.00	1.00	1.00	1.00	0.60	0.60	0.00	0.60	0.60
12 V _{OHOR}	0.20	0.20	0.20	0.20	0.20	0.20	0.20	0.20	0.20	0.20	0.20	0.20	0.20	0.20
13 V _{AHOR}	N/A*	N/A*	N/A*	N/A*	N/A*	N/A*	N/A*	N/A*	N/A*	N/A*	N/A*	N/A*	N/A*	N/A*
14 V _{COMP}	N/A	N/A	N/A	N/A	N/A	N/A	N/A	N/A	N/A	N/A	N/A	N/A	N/A	N/A
15 V _{TCOMP}	0.66	0.66	0.66	0.75	0.66	0.66	0.66	0.66	0.66	0.66	0.66	0.66	0.66	0.66
16 V _{SSD}	0.00	0.21	0.21	0.79	0.83	0.10	0.21	0.10	0.10	0.10	0.31	0.21	0.10	0.83
17 V _{GVC}	1.00	1.00	1.00	1.00	1.00	1.00	1.00	0.78	1.00	1.00	1.00	1.00	1.00	1.00
18 V _{LITTER}	0.50	0.78	0.48	1.00	1.00	0.63	0.46	0.43	0.46	0.50	0.75	0.50	0.50	1.00
19 V _{LOG}	0.41	1.00	1.00	1.00	0.67	0.00	1.00	0.98	1.00	0.71	0.30	0.00	0.41	1.00
20 V _{WD}	1.00	1.00	0.94	1.00	1.00	1.00	1.00	0.80	0.86	1.00	1.00	1.00	1.00	0.97

Table 4A. Field data collected for the LBCR study at the Caddo National Grasslands Ladonia Unit.

Variable	Plot 1	Plot 2	Plot 3	Plot 4	Plot 5	Plot 6	Plot 7	Plot 8	Plot 9	Plot 10	Plot 11	Plot 12	Plot 13	Plot 14	Plot 15
A Maturity (1-3)	2	2	2	2	2	2	2	2	2	2	2	1	1	1	1
B Climax (1-3)	2	2	2	2	2	2	2	2	2	2	2	1	1	1	1
C Disturbance (1)	1	1	1	1	1	1	1	1	1	1	1	1	1	1	1
D Notes															
1 V _{PATCH}	2500	2500	2500	2500	2500	2500	2500	2500	2500	2500	2500	2500	2500	2500	2500
2 V _{BUF30}	N/A	N/A	N/A	N/A	N/A	N/A	N/A	N/A	N/A	N/A	N/A	N/A	N/A	N/A	N/A
3 V _{BUF250}	N/A	N/A	N/A	N/A	N/A	N/A	N/A	N/A	N/A	N/A	N/A	N/A	N/A	N/A	N/A
4 V _{FREQ}	0	0	0	0	0	0	0	0	0	0	0	0	0	0	0
5 V _{DUR}	0	0	0	0	0	0	0	0	0	0	0	0	0	0	0
6 V _{POND}	40	40	40	40	40	40	40	40	40	40	40	40	40	40	40
7 V _{STRATA}	4	4	4	4	4	4	4	4	4	4	4	4	4	4	4
8 V _{SOIL}	0	0	0	0	0	0	0	0	0	0	0	0	0	0	0
9 V _{TBA}	35	32	30	35	23	23	18	23	18	21	23	25	21	14	14
10 V _{TDEN}	400	325	175	300	200	225	200	325	300	275	300	475	250	375	175
11 V _{SNAG}	0	25	50	0	25	0	25	0	25	0	0	50	50	75	100
12 V _{OHOR}	0	0	0	0	0.5	0.3	0	1.6	0.3	0.5	0.2	0.4	0.5	0.4	0.3
13 V _{AHOR}	N/A*	N/A*	N/A*	N/A*	N/A*	N/A*	N/A*	N/A*	N/A*	N/A*	N/A*	N/A*	N/A*	N/A*	N/A*
14 V _{COMP}	N/A	N/A	N/A	N/A	N/A	N/A	N/A	N/A	N/A	N/A	N/A	N/A	N/A	N/A	N/A
15 V _{TCOMP}	83	66	66	83	66	83	80	73	86	77	66	75	80	83	92
16 V _{SSD}	750	0	0	0	125	3375	1000	1625	375	5625	250	875	1125	625	1500
17 V _{GVC}	0	0	1	0	0	0	0	0	0	0	3	1	8	1	3
18 V _{LITTER}	5	5	1	2	23	50	5	88	53	54	25	79	93	99	66
19 V _{LOG}	31	0	19	26	31	0	0	23	15	27	6	50	6	0	13
20 V _{WD}	34	0	33	40	39	4	6	51	37	52	16	76	20	10	26

Table 4B. Variable subindex scores for field data collected for the LBCR study at the Caddo National Grasslands Ladonia Unit.

Variable	Plot 1	Plot 2	Plot 3	Plot 4	Plot 5	Plot 6	Plot 7	Plot 8	Plot 9	Plot 10	Plot 11	Plot 12	Plot 13	Plot 14	Plot 15
1 V _{PATCH}	1.00	1.00	1.00	1.00	1.00	1.00	1.00	1.00	1.00	1.00	1.00	1.00	1.00	1.00	1.00
2 V _{BUF30}	N/A	N/A	N/A	N/A	N/A	N/A	N/A	N/A	N/A	N/A	N/A	N/A	N/A	N/A	N/A
3 V _{BUF250}	N/A	N/A	N/A	N/A	N/A	N/A	N/A	N/A	N/A	N/A	N/A	N/A	N/A	N/A	N/A
4 V _{FREQ}	1.00	1.00	1.00	1.00	1.00	1.00	1.00	1.00	1.00	1.00	1.00	1.00	1.00	1.00	1.00
5 V _{DUR}	1.00	1.00	1.00	1.00	1.00	1.00	1.00	1.00	1.00	1.00	1.00	1.00	1.00	1.00	1.00
6 V _{POND}	1.00	1.00	1.00	1.00	1.00	1.00	1.00	1.00	1.00	1.00	1.00	1.00	1.00	1.00	1.00
7 V _{STRATA}	1.00	1.00	1.00	1.00	1.00	1.00	1.00	1.00	1.00	1.00	1.00	1.00	1.00	1.00	1.00
8 V _{SOIL}	1.00	1.00	1.00	1.00	1.00	1.00	1.00	1.00	1.00	1.00	1.00	1.00	1.00	1.00	1.00
9 V _{TBA}	1.00	1.00	1.00	1.00	1.00	1.00	1.00	1.00	1.00	1.00	1.00	1.00	1.00	1.00	1.00
10 V _{TDEN}	1.00	1.00	0.88	1.00	1.00	1.00	1.00	1.00	1.00	1.00	1.00	1.00	1.00	1.00	0.88
11 V _{SNAG}	0.00	1.00	1.00	0.00	1.00	0.00	1.00	0.00	1.00	0.00	0.00	1.00	1.00	1.00	1.00
12 V _{OHOR}	0.20	0.20	0.20	0.20	0.50	0.41	0.20	1.00	0.39	0.50	0.20	0.44	0.49	0.44	0.39
13 V _{AHOR}	N/A*	N/A*	N/A*	N/A*	N/A*	N/A*	N/A*	N/A*	N/A*	N/A*	N/A*	N/A*	N/A*	N/A*	N/A*
14 V _{COMP}	N/A	N/A	N/A	N/A	N/A	N/A	N/A	N/A	N/A	N/A	N/A	N/A	N/A	N/A	N/A
15 V _{TCOMP}	0.83	0.66	0.66	0.83	0.66	0.83	0.80	0.73	0.86	0.77	0.66	0.75	0.80	0.83	0.92
16 V _{SSD}	0.62	0.00	0.00	0.00	0.10	0.63	0.83	1.00	0.31	0.50	0.97	0.73	0.93	0.52	1.00
17 V _{GVC}	1.00	1.00	1.00	1.00	1.00	1.00	1.00	1.00	1.00	1.00	1.00	1.00	1.00	1.00	1.00
18 V _{LITTER}	0.28	0.28	0.22	0.23	0.50	0.75	0.28	1.00	0.81	0.85	0.50	1.00	1.00	1.00	1.00
19 V _{LOG}	0.99	0.00	1.00	1.00	0.98	0.00	0.00	1.00	1.00	1.00	0.04	0.50	0.72	0.00	1.00
20 V _{WD}	1.00	0.00	1.00	0.93	0.95	0.72	1.00	0.77	0.98	0.76	0.12	0.50	1.00	1.00	1.00

Table 5A. Field data collected for the LBCR study at Pat Mayse WMA.

Variable	Plot 1	Plot 2	Plot 3	Plot 4	Plot 5	Plot 6	Plot 7	Plot 8	Plot 9	Plot 10	Plot 11	Plot 12	Plot 13	Plot 14	Plot 15	Plot 16	Plot 17
A Maturity (1-3)	1	1	1	1	1	1	1	1	1	2	1	1	2	1	1	1	1
B Climax (1-3)	1	1	1	1	1	1	1	1	1	2	1	1	2	1	1	1	1
C Disturbance (1)	1	1	1	1	1	1	1	1	1	1	1	1	1	1	1	1	1
D Notes																	
1 V _{PATCH}	2500	2500	2500	2500	2500	2500	2500	2500	2500	2500	2500	2500	2500	2500	2500	2500	2500
2 V _{BUF30}	N/A	N/A	N/A	N/A	N/A	N/A	N/A	N/A	N/A	N/A	N/A	N/A	N/A	N/A	N/A	N/A	N/A
3 V _{BUF250}	N/A	N/A	N/A	N/A	N/A	N/A	N/A	N/A	N/A	N/A	N/A	N/A	N/A	N/A	N/A	N/A	N/A
4 V _{FREQ}	0	0	0	0	0	0	0	0	0	0	0	0	0	0	0	0	0
5 V _{DUR}	0	0	0	0	0	0	0	0	0	0	0	0	0	0	0	0	0
6 V _{POND}	30	30	30	30	30	30	30	30	30	30	30	30	30	30	30	30	30
7 V _{STRATA}	4	4	4	4	4	4	4	4	4	4	4	4	4	4	4	4	4
8 V _{SOIL}	0	0	0	0	0	0	0	0	0	0	0	0	0	0	0	0	0
9 V _{TBA}	30	25	16	14	21	30	21	23	30	25	23	16	18	25	30	23	25
10 V _{TDEN}	500	450	325	525	525	575	400	350	350	725	375	425	650	325	375	325	475
11 V _{SNAG}	0	50	100	25	25	50	25	75	50	25	100	75	75	25	50	25	25
12 V _{OHOR}	0.0	0.2	0.2	0.0	0.0	0.2	0.6	0.5	0.2	0.2	0.2	0.0	0.0	0.8	0.6	0.5	0.6
13 V _{AHOR}	N/A*	N/A*	N/A*	N/A*	N/A*	N/A*	N/A*	N/A*	N/A*	N/A*	N/A*	N/A*	N/A*	N/A*	N/A*	N/A*	N/A*
14 V _{COMP}	N/A	N/A	N/A	N/A	N/A	N/A	N/A	N/A	N/A	N/A	N/A	N/A	N/A	N/A	N/A	N/A	N/A
15 V _{TCOMP}	80	75	73	75	75	73	66	77	89	72	83	81	66	80	66	73	72
16 V _{SSD}	2125	125	1125	1875	250	1000	3250	625	1000	750	1375	1125	250	1500	4125	250	2625
17 V _{GVC}	5	2	4	5	9	4	5	3	1	4	44	3	1	19	20	21	13
18 V _{LITTER}	3	78	40	73	14	90	80	93	53	68	78	43	17	98	93	68	80
19 V _{LOG}	0	52	112	0	13	17	9	29	15	19	49	36	10	31	23	4	9
20 V _{WD}	12	175	118	26	29	75	38	84	54	77	89	52	30	75	49	60	33

Table 5B. Variable subindex scores for field data collected for the LBCR study at the Pat Mayse WMA

Variable	Plot 1	Plot 2	Plot 3	Plot 4	Plot 5	Plot 6	Plot 7	Plot 8	Plot 9	Plot 10	Plot 11	Plot 12	Plot 13	Plot 14	Plot 15	Plot 16	Plot 17
1 V _{PATCH}	1.00	1.00	1.00	1.00	1.00	1.00	1.00	1.00	1.00	1.00	1.00	1.00	1.00	1.00	1.00	1.00	1.00
2 V _{BUF30}	N/A	N/A	N/A	N/A	N/A	N/A	N/A	N/A	N/A	N/A	N/A	N/A	N/A	N/A	N/A	N/A	N/A
3 V _{BUF250}	N/A	N/A	N/A	N/A	N/A	N/A	N/A	N/A	N/A	N/A	N/A	N/A	N/A	N/A	N/A	N/A	N/A
4 V _{FREQ}	1.00	1.00	1.00	1.00	1.00	1.00	1.00	1.00	1.00	1.00	1.00	1.00	1.00	1.00	1.00	1.00	1.00
5 V _{DUR}	1.00	1.00	1.00	1.00	1.00	1.00	1.00	1.00	1.00	1.00	1.00	1.00	1.00	1.00	1.00	1.00	1.00
6 V _{POND}	1.00	1.00	1.00	1.00	1.00	1.00	1.00	1.00	1.00	1.00	1.00	1.00	1.00	1.00	1.00	1.00	1.00
7 V _{STRATA}	1.00	1.00	1.00	1.00	1.00	1.00	1.00	1.00	1.00	1.00	1.00	1.00	1.00	1.00	1.00	1.00	1.00
8 V _{SOIL}	1.00	1.00	1.00	1.00	1.00	1.00	1.00	1.00	1.00	1.00	1.00	1.00	1.00	1.00	1.00	1.00	1.00
9 V _{TBA}	1.00	1.00	0.90	0.77	1.00	1.00	1.00	1.00	1.00	1.00	1.00	0.90	1.00	1.00	1.00	1.00	1.00
10 V _{TDEN}	1.00	1.00	1.00	0.98	0.98	0.93	1.00	1.00	1.00	0.78	1.00	1.00	0.85	1.00	1.00	1.00	1.00
11 V _{SNAG}	0.00	1.00	1.00	1.00	1.00	1.00	1.00	1.00	1.00	1.00	1.00	1.00	1.00	1.00	1.00	1.00	1.00
12 V _{OHOR}	0.20	0.30	0.30	0.20	0.20	0.30	0.58	0.49	0.30	0.30	0.30	0.20	0.20	0.70	0.58	0.49	0.58
13 V _{AHOR}	N/A*	N/A*	N/A*	N/A*	N/A*	N/A*	N/A*	N/A*	N/A*	N/A*	N/A*	N/A*	N/A*	N/A*	N/A*	N/A*	N/A*
14 V _{COMP}	N/A	N/A	N/A	N/A	N/A	N/A	N/A	N/A	N/A	N/A	N/A	N/A	N/A	N/A	N/A	N/A	N/A
15 V _{TCOMP}	0.80	0.75	0.73	0.75	0.75	0.73	0.66	0.77	0.89	0.72	0.83	0.81	0.66	0.80	0.66	0.73	0.72
16 V _{SSD}	1.00	0.10	0.93	1.00	0.21	0.83	0.69	0.52	0.83	0.62	1.00	0.93	0.21	1.00	0.50	0.21	0.95
17 V _{GVC}	1.00	1.00	1.00	1.00	1.00	1.00	1.00	1.00	1.00	1.00	0.91	1.00	1.00	1.00	1.00	1.00	1.00
18 V _{LITTER}	0.25	1.00	0.50	1.00	0.41	1.00	1.00	1.00	0.81	1.00	1.00	0.56	0.45	1.00	1.00	1.00	1.00
19 V _{LOG}	0.00	0.50	0.50	0.00	1.00	1.00	1.00	1.00	1.00	1.00	0.53	0.84	1.00	0.98	1.00	0.50	1.00
20 V _{WD}	1.00	0.50	0.50	1.00	1.00	0.50	0.95	0.50	0.73	0.50	0.50	0.75	1.00	0.50	0.80	0.65	1.00

Table 6A. Field data collected for the LBCR study at Cooper WMA

Variable	Plot 1	Plot 2	Plot 3	Plot 4	Plot 5	Plot 6
A Maturity (1-3)	3	2	1	1	1	1
B Climax (1-3)	3	2	2	2	1	2
C Disturbance (1)	1	1	1	1	1	1
D Notes						
1 V _{PATCH}	2500	2500	2500	2500	2500	2500
2 V _{BUF30}	N/A	N/A	N/A	N/A	N/A	N/A
3 V _{BUF250}	N/A	N/A	N/A	N/A	N/A	N/A
4 V _{FREQ}	0	0	0	0	0	0
5 V _{DUR}	0	0	0	0	0	0
6 V _{POND}	20	20	20	20	20	20
7 V _{STRATA}	4	4	4	4	4	4
8 V _{SOIL}	0	0	0	0	0	0
9 V _{TBA}	37	35	35	28	16	28
10 V _{TDEN}	1050	700	475	500	300	225
11 V _{SNAG}	25	25	75	25	50	25
12 V _{OHOR}	0	0	0	0	0	0
13 V _{AHOR}	N/A*	N/A*	N/A*	N/A*	N/A*	N/A*
14 V _{COMP}	N/A	N/A	N/A	N/A	N/A	N/A
15 V _{TCOMP}	75	76	83	72	83	83
16 V _{SSD}	2000	1750	1250	1625	1875	2875
17 V _{GVC}	8	5	1	5	16	7
18 V _{LITTER}	7	1	31	93	93	59
19 V _{LOG}	0	14	40	18	18	7
20 V _{WD}	21	30	63	23	57	56

Table 6B. Variable subindex scores for field data collected for the LBCR study at Cooper WMA

Variable	Plot 1	Plot 2	Plot 3	Plot 4	Plot 5	Plot 6
1 V _{PATCH}	1.00	1.00	1.00	1.00	1.00	1.00
2 V _{BUF30}	N/A	N/A	N/A	N/A	N/A	N/A
3 V _{BUF250}	N/A	N/A	N/A	N/A	N/A	N/A
4 V _{FREQ}	1.00	1.00	1.00	1.00	1.00	1.00
5 V _{DUR}	1.00	1.00	1.00	1.00	1.00	1.00
6 V _{POND}	1.00	1.00	1.00	1.00	1.00	1.00
7 V _{STRATA}	1.00	1.00	1.00	1.00	1.00	1.00
8 V _{SOIL}	1.00	1.00	1.00	1.00	1.00	1.00
9 V _{TBA}	1.00	1.00	1.00	1.00	0.90	1.00
10 V _{TDEN}	0.50	0.80	1.00	1.00	1.00	1.00
11 V _{SNAG}	1.00	1.00	1.00	1.00	1.00	1.00
12 V _{OHOR}	0.20	0.20	0.20	0.20	0.20	0.20
13 V _{AHOR}	N/A*	N/A*	N/A*	N/A*	N/A*	N/A*
14 V _{COMP}	N/A	N/A	N/A	N/A	N/A	N/A
15 V _{TCOMP}	0.75	0.76	0.83	0.72	0.83	0.83
16 V _{SSD}	1.00	1.00	1.00	1.00	1.00	0.84
17 V _{GVC}	1.00	1.00	1.00	1.00	1.00	1.00
18 V _{LITTER}	0.30	0.22	0.50	1.00	1.00	0.97
19 V _{LOG}	0.00	1.00	0.74	1.00	1.00	0.87
20 V _{WD}	1.00	1.00	0.60	1.00	0.69	0.69

Table 7A. Field data collected for the LBCR study at Lennox Woods.

Variable	Plot 1	Plot 2	Plot 3	Plot 4	Plot 5	Plot 6	Plot 7	Plot 8
A Maturity (1-3)	2	2	2	2	2	2	2	2
B Climax (1-3)	2	2	2	2	2	2	2	2
C Disturbance (1)	1	1	1	1	1	1	1	1
D Notes								
1 V_{PATCH}	2500	2500	2500	2500	2500	2500	2500	2500
2 V_{BUF30}	N/A	N/A	N/A	N/A	N/A	N/A	N/A	N/A
3 V_{BUF250}	N/A	N/A	N/A	N/A	N/A	N/A	N/A	N/A
4 V_{FREQ}	0	0	0	0	0	0	0	0
5 V_{DUR}	0	0	0	0	0	0	0	0
6 V_{POND}	30	30	30	30	30	30	30	30
7 V_{STRATA}	4	4	4	4	4	4	4	4
8 V_{SOIL}	0	0	0	0	0	0	0	0
9 V_{TBA}	25	23	25	32	35	25	23	23
10 V_{TDEN}	525	350	425	300	550	375	475	325
11 V_{SNAG}	0	25	25	0	0	25	150	0
12 V_{OHOR}	0.3	0.7	0.2	0.2	0.4	0.1	0.5	0.2
13 V_{AHOR}	N/A*	N/A*	N/A*	N/A*	N/A*	N/A*	N/A*	N/A*
14 V_{COMP}	N/A	N/A	N/A	N/A	N/A	N/A	N/A	N/A
15 V_{TCOMP}	76	83	71	80	86	89	89	92
16 V_{SSD}	750	3500	2000	2125	625	1125	250	1625
17 V_{GVC}	3	0	2	0	3	1	0	2
18 V_{LITTER}	68	73	11	39	83	14	29	35
19 V_{LOG}	69	0	0	3	0	0	0	0
20 V_{WD}	93	5	3	10	4	4	6	4

Table 7B. Variable subindex scores for field data collected for the LBCR study at Lennox Woods.

Variable	Plot 1	Plot 2	Plot 3	Plot 4	Plot 5	Plot 6	Plot 7	Plot 8
1 V _{PATCH}	1.00	1.00	1.00	1.00	1.00	1.00	1.00	1.00
2 V _{BUF30}	N/A	N/A	N/A	N/A	N/A	N/A	N/A	N/A
3 V _{BUF250}	N/A	N/A	N/A	N/A	N/A	N/A	N/A	N/A
4 V _{FREQ}	1.00	1.00	1.00	1.00	1.00	1.00	1.00	1.00
5 V _{DUR}	1.00	1.00	1.00	1.00	1.00	1.00	1.00	1.00
6 V _{POND}	1.00	1.00	1.00	1.00	1.00	1.00	1.00	1.00
7 V _{STRATA}	1.00	1.00	1.00	1.00	1.00	1.00	1.00	1.00
8 V _{SOIL}	1.00	1.00	1.00	1.00	1.00	1.00	1.00	1.00
9 V _{TBA}	1.00	1.00	1.00	1.00	1.00	1.00	1.00	1.00
10 V _{TDEN}	0.98	1.00	1.00	1.00	0.95	1.00	1.00	1.00
11 V _{SNAG}	0.00	1.00	1.00	0.00	0.00	1.00	0.60	0.00
12 V _{OHOR}	0.39	0.65	0.34	0.34	0.44	0.25	0.50	0.34
13 V _{AHOR}	N/A*	N/A*	N/A*	N/A*	N/A*	N/A*	N/A*	N/A*
14 V _{COMP}	N/A	N/A	N/A	N/A	N/A	N/A	N/A	N/A
15 V _{TCOMP}	0.76	0.83	0.71	0.80	0.86	0.89	0.89	0.92
16 V _{SSD}	0.62	0.58	1.00	1.00	0.52	0.93	0.21	1.00
17 V _{GVC}	1.00	1.00	1.00	1.00	1.00	1.00	1.00	1.00
18 V _{LITTER}	1.00	1.00	0.36	0.50	1.00	0.41	0.50	0.50
19 V _{LOG}	0.50	0.00	0.00	0.41	0.00	0.00	0.00	0.00
20 V _{WD}	0.50	0.98	0.69	1.00	0.87	0.72	1.00	0.72

Species Grouping

Table 8. Modified LBCR HGM species grouping for determining V_{TCOMP} .

Group 1		Group 2		Group 3	
Pecan	<i>Carya illinoensis</i>	Box Elder	<i>Acer negundo</i>	Eastern Redbud	<i>Cercis canadensis</i>
Sugarberry	<i>Celtis laevigata</i>	Red Maple	<i>Acer rubrum</i>	Hawthorn	<i>Crataegus spp.</i>
Ash	<i>Fraxinus spp.</i>	Hickory Spp.	<i>Carya spp.</i>	Honey Locust	<i>Gleditsia triacanthos</i>
Bur Oak	<i>Quercus macrocarpa</i>	Dogwood	<i>Cornus spp.</i>	Eastern Red Cedar	<i>Juniperus virginiana</i>
Water Oak	<i>Quercus nigra</i>	Persimmon	<i>Diospyros spp.</i>	Bois D'Arc	<i>Maclura pomifera</i>
Willow Oak	<i>Quercus phellos</i>	Black Walnut	<i>Juglans nigra</i>	Eastern Cottonwood	<i>Populus deltoides</i>
Shumard Oak	<i>Quercus shumardii</i>	Sycamore	<i>Platanus occidentalis</i>	Black Willow	<i>Salix nigra</i>
Elm	<i>Ulmus spp.</i>	Overcup Oak	<i>Quercus lyrata</i>	Soapberry	<i>Sapindus spp.</i>
		Cherrybark Oak	<i>Quercus pagoda</i>		

Group 1 = Common dominants in reference standard sites

Group 2 = Species commonly present in reference standard sites, but dominance generally indicates man-made or natural disturbance

Group 3 = Uncommon, minor or shrub species in reference standard sites, but may dominate in degraded systems

Tree Count by Species

Table 9A. Tree count by species for plots at Caddo National Grasslands Bois D'Arc Unit.

	<i>Fraxinus pennsylvanica</i> Green Ash	<i>Celtis laevigata</i> Sugarberry	<i>Ulmus crassifolia</i> Cedar Elm	<i>Quercus macrocarpa</i> Bur Oak	<i>Ulmus americana</i> American Elm	<i>Maclura pomifera</i> Bois D'Arc
Plot 1	12	12	0	0	0	0
Plot 2	10	16	0	0	0	0
Plot 3	16	17	0	0	0	0
Plot 4	9	5	7	1	0	0
Plot 5	18	0	13	0	0	0
Plot 6	14	5	1	0	0	0
Plot 7	19	10	1	0	0	0
Plot 8	4	1	0	0	2	6
Plot 9	7	3	2	0	0	6
Plot 10	16	6	3	0	0	0
Plot 11	6	8	2	0	0	1
Plot 12	14	14	0	0	0	2
Plot 13	3	5	6	0	0	2
Plot 14	0	5	5	0	0	1

Table 9A continued.

	<i>Sapindus</i> spp. Soapberry	Total # Trees	Total # <i>Quercus</i> spp.	% <i>Quercus</i> spp.	Total # Hard Mast Producers	% Hard Mast Producers
Plot 1	0	24	0	0	0	0
Plot 2	0	26	0	0	0	0
Plot 3	0	33	0	0	0	0
Plot 4	0	22	1	4.5	1	4.5
Plot 5	0	31	0	0	0	0
Plot 6	0	20	0	0	0	0
Plot 7	0	30	0	0	0	0
Plot 8	0	13	0	0	0	0
Plot 9	0	18	0	0	0	0
Plot 10	0	25	0	0	0	0
Plot 11	0	17	0	0	0	0
Plot 12	0	30	0	0	0	0
Plot 13	0	16	0	0	0	0
Plot 14	2	13	0	0	0	0

Table 9B. Tree count by species for plots at Caddo National Grasslands Ladonia Unit.

	Fraxinus pennsylvanica Green Ash	Celtis laevigata Sugarberry	Ulmus crassifolia Cedar Elm	Quercus macrocarpa Bur Oak	Ulmus americana American Elm	Maclura pomifera Bois D'Arc	Sapindus spp. Soapberry
Plot 1	3	2	1	0	0	6	0
Plot 2	3	7	6	1	0	3	0
Plot 3	4	6	1	0	0	0	0
Plot 4	2	6	1	0	0	0	2

Table 9B continued.

	Diospyros virginiana Persimmon	Platanus occidentalis Sycamore	Total # Trees	Total # Quercus spp.	% Quercus spp.	Total # Hard Mast Producers	% Hard Mast Producers
Plot 1	0	0	12	0	0	0	0
Plot 2	0	0	20	1	5	1	5
Plot 3	0	0	11	0	0	0	0
Plot 4	1	1	13	0	0	0	0

Table 9C. Tree count by species for plots at White Oak WMA.

	Fraxinus pennsylvanica Green Ash	Celtis laevigata Sugarberry	Ulmus crassifolia Cedar Elm	Ulmus americana American Elm	Maclura pomifera Bois D'Arc	Sapindus spp. Soapberry	Diospyros virginiana Persimmon	Quercus lyrata Overcup Oak
Plot 1	0	0	0	0	0	0	0	15
Plot 2	0	0	0	0	0	0	0	12
Plot 3	2	0	0	0	0	0	0	5
Plot 4	0	0	0	0	0	0	0	11
Plot 5	0	0	0	0	0	0	0	6
Plot 6	0	0	0	0	0	0	0	7
Plot 7	1	0	0	0	0	0	0	3
Plot 8	1	2	7	0	0	0	0	2
Plot 9	0	2	7	0	0	0	0	0
Plot 10	0	0	2	0	0	0	0	5
Plot 11	0	1	3	0	1	0	1	4
Plot 12	1	0	0	2	0	0	0	3
Plot 13	0	2	0	3	0	0	0	1
Plot 14	0	0	0	0	0	0	0	2
Plot 15	0	0	0	0	0	0	0	0

Table 9C continued.

	Carya illinoensis Pecan	Planera aquatica Water Elm	Quercus nigra Water Oak	Ulmus rubra Slippery Elm	Gleditsia triacanthos Honey Locust	Quercus pagoda Cherrybark Oak	Quercus phellos Willow Oak	Quercus alba White Oak
Plot 1	1	0	0	0	0	0	0	0
Plot 2	0	1	0	0	0	0	0	0
Plot 3	0	0	0	0	0	0	0	0
Plot 4	0	0	1	0	0	0	0	0
Plot 5	0	2	0	0	0	0	0	0
Plot 6	2	0	0	0	0	0	0	0
Plot 7	1	0	2	1	0	0	0	0
Plot 8	0	0	0	0	1	0	0	0
Plot 9	0	0	0	0	1	1	1	0
Plot 10	0	1	3	0	0	0	0	0
Plot 11	0	0	2	0	0	0	0	0
Plot 12	0	0	6	0	0	4	1	0
Plot 13	0	0	0	0	0	1	3	0
Plot 14	0	0	0	0	0	4	2	1
Plot 15	0	0	3	0	0	1	2	0

Table 9C continued.

	Carpinus caroliniana American Hornbeam	Liquidambar styraciflua Sweetgum	Total # Trees	Total # Quercus spp.	% Quercus spp.	Total # Hard Mast Producers	% Hard Mast Producers
Plot 1	0	0	16	15	93.8	16.0	100.0
Plot 2	0	0	13	12	92.3	12.0	92.3
Plot 3	0	0	7	5	71.4	5.0	71.4
Plot 4	0	0	12	12	100.0	12.0	100.0
Plot 5	0	0	8	6	75.0	6.0	75.0
Plot 6	0	0	9	7	77.8	9.0	100.0
Plot 7	0	0	8	5	62.5	6.0	75.0
Plot 8	0	0	13	2	15.4	2.0	15.4
Plot 9	0	0	12	2	16.7	2.0	16.7
Plot 10	0	0	11	8	72.7	8.0	72.7
Plot 11	0	0	12	6	50.0	6.0	50.0
Plot 12	1	1	19	14	73.7	14.0	73.7
Plot 13	0	0	10	5	50.0	5.0	50.0
Plot 14	0	3	15	9	60.0	9.0	60.0
Plot 15	0	1	7	6	85.7	6.0	85.7

Table 9D. Tree count by species for plots at Cooper WMA.

	Fraxinus pennsylvanica Green Ash	Celtis laevigata Sugarberry	Ulmus crassifolia Cedar Elm	Quercus macrocarpa Bur Oak	Maclura pomifera Bois D'Arc
Plot 1	8	32	1	1	0
Plot 2	7	15	1	1	1
Plot 3	5	5	1	0	0
Plot 4	0	10	1	0	0
Plot 5	1	9	0	0	0
Plot 6	0	1	0	0	0

Table 9D continued.

	Sapindus spp. Soapberry	Carya illinoensis Pecan	Quercus nigra Water Oak	Quercus shumardii Shumard Oak	Acer negundo Box Elder
Plot 1	0	0	0	0	0
Plot 2	0	0	1	2	0
Plot 3	0	1	5	2	0
Plot 4	1	2	0	1	5
Plot 5	0	1	0	1	0
Plot 6	0	6	1	0	1

Table 9D continued.

	Total # Trees	Total # Quercus spp.	% Quercus spp.	Total # Hard Mast Producers	% Hard Mast Producers
Plot 1	42	1	2.4	1	2.4
Plot 2	28	4	14.3	4	14.3
Plot 3	19	7	36.8	8	42.1
Plot 4	20	1	5.0	3	15.0
Plot 5	12	1	8.3	2	16.7
Plot 6	9	1	11.1	7	77.8

Table 9E. Tree count by species for plots at Pat Mayse WMA.

	Fraxinus pennsylvanica Green Ash	Celtis laevigata Sugarberry	Ulmus crassifolia Cedar Elm	Quercus macrocarpa Bur Oak	Maclura pomifera Bois D'Arc	Platanus occidentalis Sycamore	Carya illinoensis Pecan
Plot 1	0	4	5	0	0	2	0
Plot 2	0	4	2	0	0	0	6
Plot 3	2	5	1	0	0	1	4
Plot 4	13	2	4	0	0	0	2
Plot 5	1	6	12	0	0	0	0
Plot 6	0	0	2	0	0	0	6
Plot 7	0	0	0	0	2	0	2
Plot 8	1	0	2	0	0	0	0
Plot 9	0	0	3	1	0	0	0
Plot 10	0	17	7	0	1	0	1
Plot 11	0	9	2	0	0	0	1
Plot 12	0	1	7	0	3	0	1
Plot 13	4	10	10	0	1	0	1
Plot 14	0	2	6	0	0	0	1
Plot 15	5	3	3	0	1	0	0
Plot 16	0	1	1	1	7	0	3
Plot 17	1	1	7	0	3	0	4

Table 9E continued.

	Quercus nigra Water Oak	Gleditsia triacanthos Honey Locust	Quercus shumardii Shumard Oak	Juniperus virginiana Eastern Red Cedar	Carya ovata Shagbark Hickory	Quercus stellata Post Oak	Carya cordiformis Bitternut Hickory
Plot 1	0	0	4	0	0	0	0
Plot 2	0	0	0	0	0	0	0
Plot 3	0	0	0	0	0	0	0
Plot 4	0	0	0	0	0	0	0
Plot 5	1	0	0	0	0	0	0
Plot 6	13	1	0	1	0	0	0
Plot 7	5	0	0	7	0	0	0
Plot 8	11	0	0	0	0	0	0
Plot 9	9	0	0	0	0	0	0
Plot 10	0	0	0	0	0	0	2
Plot 11	3	0	0	0	0	0	0
Plot 12	0	0	1	0	3	1	0
Plot 13	0	0	0	0	0	0	0
Plot 14	3	0	0	0	0	0	0
Plot 15	2	0	0	0	0	0	0
Plot 16	0	0	0	0	0	0	0
Plot 17	3	0	0	0	0	0	0

Table 9E continued.

	Ulmus alata Winged Elm	Acer negundo Box Elder	Total # Trees	Total # Quercus spp.	% Quercus spp.	Total # Hard Mast Producers	% Hard Mast Producers
Plot 1	0	0	15	4	26.7	4	26.7
Plot 2	0	6	18	0	0.0	6	33.3
Plot 3	0	0	13	0	0.0	4	30.8
Plot 4	0	0	21	0	0.0	2	9.5
Plot 5	1	0	21	1	4.8	1	4.8
Plot 6	0	0	23	13	56.5	19	82.6
Plot 7	0	0	16	5	31.3	7	43.8
Plot 8	0	0	14	11	78.6	11	78.6
Plot 9	1	0	14	10	71.4	10	71.4
Plot 10	0	0	28	0	0.0	3	10.7
Plot 11	0	0	15	3	20.0	4	26.7
Plot 12	0	0	17	2	11.8	6	35.3
Plot 13	0	0	26	0	0.0	1	3.8
Plot 14	0	0	12	3	25.0	4	33.3
Plot 15	1	0	15	2	13.3	2	13.3
Plot 16	0	0	13	1	7.7	4	30.8
Plot 17	0	0	19	3	15.8	7	36.8

Table 9F. Tree count by species for plots at Lennox Woods.

	Fraxinus pennsylvanica Green Ash	Celtis laevigata Sugarberry	Ulmus americana American Elm	Quercus nigra Water Oak	Quercus shumardii Shumard Oak	Carya ovata Shagbark Hickory	Carya cordiformis Bitternut Hickory	Quercus falcata Southern Red Oak
Plot 1	0	1	0	1	0	0	7	0
Plot 2	0	0	1	6	0	0	1	0
Plot 3	0	0	0	1	0	4	0	0
Plot 4	0	0	0	4	0	1	0	0
Plot 5	0	0	0	1	2	8	0	0
Plot 6	0	0	1	1	0	2	3	1
Plot 7	0	0	1	3	0	12	0	1
Plot 8	1	0	0	3	0	8	0	0

Table 9F continued.

	Pinus taeda Loblolly Pine	Pinus echinata Shortleaf Pine	Acer rubrum Red Maple	Quercus alba White Oak	Carya texana Black Hickory	Cornus spp. Dogwood	Carpinus caroliniana American Hornbeam	Liquidambar styraciflua Sweetgum
Plot 1	0	0	0	1	0	2	1	1
Plot 2	0	0	0	2	1	1	0	2
Plot 3	0	1	1	2	0	0	2	6
Plot 4	3	0	0	2	0	0	0	2
Plot 5	0	0	0	0	0	1	0	10
Plot 6	0	0	0	5	0	0	0	2
Plot 7	0	0	0	1	0	0	0	1
Plot 8	0	0	0	1	0	0	0	0

Table 9F continued.

	Ulmus alata Winged Elm	Total # Trees	Total # Quercus spp.	% Quercus spp.	Total # Hard Mast Producers	% Hard Mast Producers
Plot 1	7	21	2	9.5	9	42.9
Plot 2	0	14	8	57.1	10	71.4
Plot 3	0	17	3	17.6	7	41.2
Plot 4	0	12	6	50.0	7	58.3
Plot 5	0	22	3	13.6	11	50.0
Plot 6	0	15	7	46.7	12	80.0
Plot 7	0	19	5	26.3	17	89.5
Plot 8	0	13	4	30.8	12	92.3

Calculations

Original East Texas FCI Models

a. *Detain Floodwater.*

$$FCI = V_{FREQ} \times \left[\frac{(V_{LOG} + V_{GVC} + V_{SSD} + V_{TDEN})}{4} \right]$$

b. *Detain Precipitation.*

$$FCI = \frac{\left[V_{POND} + \frac{(V_{OHOR} + V_{LITTER})}{2} \right]}{2}$$

c. *Cycle Nutrients.*

$$FCI = \frac{\left[\frac{(V_{TBA} + V_{SSD} + V_{GCV})}{3} + \frac{(V_{OHOR} + V_{AHOR} + V_{WD} + V_{SNAG})}{4} \right]}{2}$$

d. *Export Organic Carbon.*

$$FCI = V_{FREQ} \times \frac{\left[\frac{(V_{LITTER} + V_{OHOR} + V_{WD} + V_{SNAG})}{4} + \frac{(V_{TBA} + V_{SSD} + V_{GVC})}{3} \right]}{2}$$

e. *Maintain Plant Communities.*

$$FCI = \left\{ \frac{\left[\frac{(V_{TBA} + V_{TDEN})}{2} + V_{COMP} \right]}{2} \right\} \times \left[\frac{(V_{SOIL} + V_{DUR} + V_{POND})}{3} \right]^{1/2}$$

f. *Provide Habitat for Fish and Wildlife.*

$$FCI = \left\{ \left[\frac{(V_{FREQ} + V_{DUR} + V_{POND})}{3} \right] \times \left[\frac{(V_{TCOMP} + V_{STRATA} + V_{SNAG} + V_{TBA})}{4} \right] \right\}^{1/4} \times \left[\frac{(V_{LOG} + V_{OHOR})}{2} \right] \times V_{PATCH}$$

Modified Fannin County Models

a. *Detain Floodwater.*

$$FCI = V_{FREQ} \times \left[\frac{(V_{LOG} + V_{GVC} + V_{SSD} + V_{TDEN})}{4} \right]$$

b. *Detain Precipitation.*

$$FCI = \frac{[V_{POND} + \frac{(V_{OHOR} + V_{LITTER})}{2}]}{2}$$

c. *Cycle Nutrients.*

$$FCI = \frac{[\frac{(V_{TBA} + V_{SSD} + V_{GCV})}{3} + \frac{(V_{OHOR} + V_{WD} + V_{SNAG})}{3}]}{2}$$

d. *Export Organic Carbon.*

$$FCI = V_{FREQ} \times \frac{[\frac{(V_{LITTER} + V_{OHOR} + V_{WD} + V_{SNAG})}{4} + \frac{(V_{TBA} + V_{SSD} + V_{GVC})}{3}]}{2}$$

e. *Maintain Plant Communities.*

$$FCI = \left[\left\{ \frac{[\frac{(V_{TBA} + V_{TDEN})}{2} + V_{COMP}]}{2} \right\} \times \left[\frac{(V_{SOIL} + V_{DUR} + V_{POND})}{3} \right] \right]^{1/2}$$

f. *Provide Habitat for Fish and Wildlife.*

$$FCI = \left\{ \left[\frac{(V_{FREQ} + V_{DUR} + V_{POND})}{3} \right] \times \left[\frac{(V_{TCOMP} + V_{STRATA} + V_{SNAG} + V_{TBA})}{4} \right] \right\}^{1/4} \times \left[\frac{(V_{LOG} + V_{OHOR})}{2} \right] \times V_{PATCH}$$

Modified Fannin County Flats Models

a. *Detain Floodwater.* Not Assessed.

b. *Detain Precipitation.*

$$FCI = \frac{\left[V_{POND} + \frac{(V_{OHOR} + V_{LITTER})}{2} \right]}{2}$$

c. *Cycle Nutrients.*

$$FCI = \frac{\left[\frac{(V_{TBA} + V_{SSD} + V_{GCV})}{3} + \frac{(V_{OHOR} + V_{WD} + V_{SNAG})}{3} \right]}{2}$$

d. *Export Organic Carbon.* Not Assessed.

e. *Maintain Plant Communities.*

$$FCI = \left\{ \left[\frac{(V_{TBA} + V_{TDEN})}{2} + V_{COMP} \right] \times \left[\frac{(V_{SOIL} + V_{POND})}{2} \right] \right\}^{1/2}$$

f. *Provide Habitat for Fish and Wildlife.*

$$FCI = \left\{ V_{POND} \times \left[\frac{(V_{TCOMP} + V_{STRATA} + V_{SNAG} + V_{TBA})}{4} \right] \right. \\ \left. \times \left[\frac{(V_{LOG} + V_{OHOR})}{2} \right] \times V_{PATCH} \right\}^{1/4}$$

Adjusted Quality Index Calculation for V_{TCOMP}

Initial Quality Index

$$= \frac{[(\# \text{ of dominants from Group 1} \times 1.0) + (\# \text{ of dominants from Group 2} \times 0.66) + (\# \text{ of dominants from Group 3} \times 0.33)]}{\# \text{ of dominants from Groups 1, 2, and 3}}$$

$$VSI = \text{Adjusted Quality Index}$$

Where if there are 3 or more dominants from Groups 1 and 2:

$$\text{Adjusted Quality Index} = 1.0 \times \text{Initial Quality Index}$$

Where if there are 2 dominants from Groups 1 and 2:

$$\text{Adjusted Quality Index} = 0.66 \times \text{Initial Quality Index}$$

Where if there is 1 dominant from Groups 1 and 2:

$$\text{Adjusted Quality Index} = 0.33 \times \text{Initial Quality Index}$$

And if there are 0 dominants from Groups 1 and 2:

$$\text{Adjusted Quality Index} = 0.10 \times \text{Initial Quality Index}$$

**APPENDIX L: RAPID GEOMORPHIC ASSESSMENTS
(RGA) CONDUCTED FOR THE
PROPOSED LOWER BOIS D'ARC CREEK
RESERVOIR SITE IN 2008 AND 2016**

**L-1: RAPID GEOMORPHIC ASSESSMENT OF BOIS D'ARC CREEK AND ITS
TRIBUTARIES FOR THE LOWER BOIS D'ARC CREEK RESERVOIR
PROJECT (2008)**

**L-2: SUPPLEMENTAL RAPID GEOMORPHIC ASSESSMENT DATA
COLLECTION AT THE PROPOSED LOWER BOIS D'ARC CREEK
RESERVOIR SITE (2016)**

Phase I

**Rapid Geomorphic Assessment of
Bois d'Arc Creek and its Tributaries for the
Lower Bois d'Arc Creek Reservoir Project**

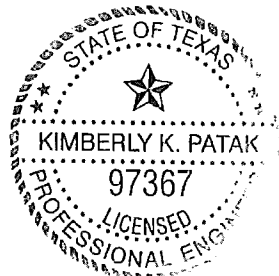

K Patak 9/18/08

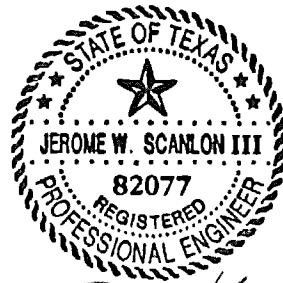

Jerome W. Scanlon III
9/18/2008



**Rapid Geomorphic Assessment of Bois d’Arc Creek and its Tributaries
for the
Lower Bois d’Arc Creek Reservoir Project**

Table of Contents

Executive Summary	i
1.0 Introduction	1
2.0 Basin History	3
2.1 Ecoregions	3
2.2 Geologic Setting	5
2.3 Soils	7
2.4 Historical Land Use Practices	8
3.0 Incised Channel Evolution Model	10
4.0 Methods	13
4.1 Field Collected Data	13
4.2 Channel Stability Variables	20
4.3 Channel Stability Rating	24
5.0 Results	26
5.1 Bois d’Arc Creek	26
5.2 Honey Grove Creek	47
5.3 Ward Creek	53
5.4 Bullard Creek	58
5.5 Sandy Creek	63
5.6 Summary of Stream Classification	68

Appendix A – Rapid Assessment Classification Forms

Appendix B - References

Appendix C – Glossary of Terms

List of Figures:

Figure 1.1 – Location Map	1
Figure 2.2 – Geologic Map	4
Figure 3.1 – Incised Channel Evolution Model.....	9
Figure 4.1 – Data Collection Points.....	1
Figure 4.2 – Data Collection Sheet	2
Figure 4.3 – Bank Stability Form	3
Figure 4.4 –Channel Stability Form.....	1
Figure 4.5 – Rapid Assessment Classification Sheet	6
Figure 5.1 – Bois d’Arc Creek Reach Locations	9
Figure 5.2 – Bois d’Arc Creek Longitudinal Profile	9
Figure 5.2 – Bois d’Arc Creek Longitudinal Profile	10
Figure 5.3 – Bois d’Arc Creek Longitudinal Profile	11
Figure 5.4 - Comparison of Historic to Existing Channel Alignment for Reach 1 of Bois d’Arc Creek.....	12
Figure 5.5 - Reach 1 of Bois d’Arc Creek.....	13
Figure 5.6 - Chute Cutoff in Reach 2 of Bois d’Arc Creek.....	13
Figure 5.7 - Reach 2 of Bois d’Arc Creek during winter.....	14
Figure 5.8 - Reach 2 of Bois d’Arc Creek during summer.....	14
Figure 5.8b - Reach 2 of Bois d’Arc Creek showing the formation of an inner berm.....	15
Figure 5.9 - Comparison of Historic to Existing Channel Alignment for Reach 3 of Bois d’Arc Creek.....	16
Figure 5.10 - Reach 3 of Bois d’Arc Creek during summer.....	16
Figure 5.11 - Reach 3 of Bois d’Arc Creek during winter.	17
Figure 5.12 - Comparison of Historic to Existing Channel Alignment for Reach 4 of Bois d’Arc Creek.....	18
Figure 5.13 - Reach 4 of Bois d’Arc Creek during winter	18
Figure 5.14 - Reach 4 of Bois d’Arc Creek after summer rain event	19
Figure 5.15 - Comparison of Historic to Existing Channel Alignment for Reach 5 of Bois d’Arc Creek.....	20
Figure 5.16 - A “poor” rated reach on Reach 5 of Bois d’Arc Creek.....	21
Figure 5.17 - A “fair” rated reach on Reach 5 of Bois d’Arc Creek.	21
Figure 5.18 - A “poor” rated reach on Reach 5 of Bois d’Arc Creek.....	22
Figure 5.19 - A “fair” rated reach on Reach 5 of Bois d’Arc Creek.	22

Figure 5.20 – Bois d’Arc Creek Classification	24
Figure 5.21 – Bois d’Arc Creek Classification	25
Figure 5.22 – Bois d’Arc Creek Classification	26
Figure 5.23 – Bois d’Arc Creek Classification	27
Figure 5.24 - Comparison of Historic to Existing Channel Alignment on Honey Grove Creek.....	28
Figure 5.25 – Honey Grove Creek Longitudinal Profile	30
Figure 5.26: Poor rated section of Honey Grove Creek along lower reach.....	31
Figure 5.27: Fair rated section of Honey Grove Creek along lower reach.	31
Figure 5.28: Fair rated section of Honey Grove Creek along upper reach.....	32
Figure 5.29 – Honey Grove Creek Classification.....	33
Figure 5.30 - Comparison of Historic to Existing Channel Alignment on Ward Creek...	34
Figure 5.31 – Ward Creek Longitudinal Profile	35
Figure 5.32 – Typical view of Ward Creek	36
Figure 5.33 - View of Ward Creek with evidence of mass wasting.	36
Figure 5.34 – Ward Creek Classification.....	38
Figure 5.35 - Comparison of Historic to Existing Channel Alignment on Bullard Creek.	39
Figure 5.36 – Bullard Creek Longitudinal Profile	40
Figure 5.37 - A “poor” rated stream on Bullard Creek.....	41
Figure 5.38 - A “fair” rated stream on Bullard Creek	41
Figure 5.39 – Bullard Creek Classification	43
Figure 5.40 - Comparison of Historic to Existing Channel Alignment on Sandy Creek..	44
Figure 5.41 – Sandy Creek Longitudinal Profile.....	46
Figure 5.42: Typical View of Sandy Creek with vertical side slopes.....	47
Figure 5.43: Typical view of Sandy Creek with flatter side slopes.....	47
Figure 5.44 – Sandy Creek Classification	48

List of Tables:

Table 4.1 - Field Data Points.....	1
Table 5.1 - Summary of Lower Bois d’Arc Creek Reach Information	7
Table 5.2 – Channel Classification.....	50

Executive Summary

Introduction

The North Texas Municipal Water District (NTMWD) is proposing to build an approximately 367,600 acre-foot water supply reservoir (Lower Bois d'Arc Creek Reservoir) on Bois d'Arc and Honey Grove Creeks approximately 15 miles northeast of Bonham in Fannin County, Texas. The primary objective of this study is to perform a rapid geomorphic stability assessment of Bois d'Arc Creek and four major tributaries (Honey Grove Creek, Sandy Creek, Ward Creek, and Bullard Creek) within the inundation pool of the proposed reservoir (Figure ES-1). In terms of reconnaissance and information evaluation, this rapid assessment is similar to Step 1 of the "Texas Instream Flow Studies: Technical Overview" (TWDB, 2008). The results of this geomorphic assessment will be used in conjunction with the environmental report and habitat assessment developed by Freese and Nichols, Inc. (FNI) to describe the existing conditions of the riverine system.

The stream channel patterns and characteristics of the Bois d'Arc system are greatly influenced by the geologic lithology and structure occurring in Fannin County. In general, the streams and creeks in Fannin County, including Bois d'Arc Creek, flow in channels cut through alluvium and fluvial terrace deposits which were deposited by larger streams during the Pleistocene and Holocene Epochs of the Quaternary Period (USDA, 2001). The alluvial deposits in the channels of Bois d'Arc Creek, Sandy Creek, Bullard Creek, Ward Creek, and Honey Grove Creek were derived from Upper Cretaceous bedrock which lies directly beneath the alluvium (USDA, 2001). This Upper Cretaceous bedrock is also visible at the surface on either side of the respective stream channels (BEG, 1967).

According to a historical map dated circa 1915 and aerial photography dated 1950, 1970, and 2005, the land surrounding the Bois d'Arc Creek system remains largely undeveloped, rural land predominantly used for agricultural purposes. There is evidence by the historical data that landowners have modified the terrain by digging drainage channels through their property, bypassing and sometimes abandoning the natural riverine system. This channelization has resulted in the creeks incising, causing down cutting of the channel bottom throughout the reaches.

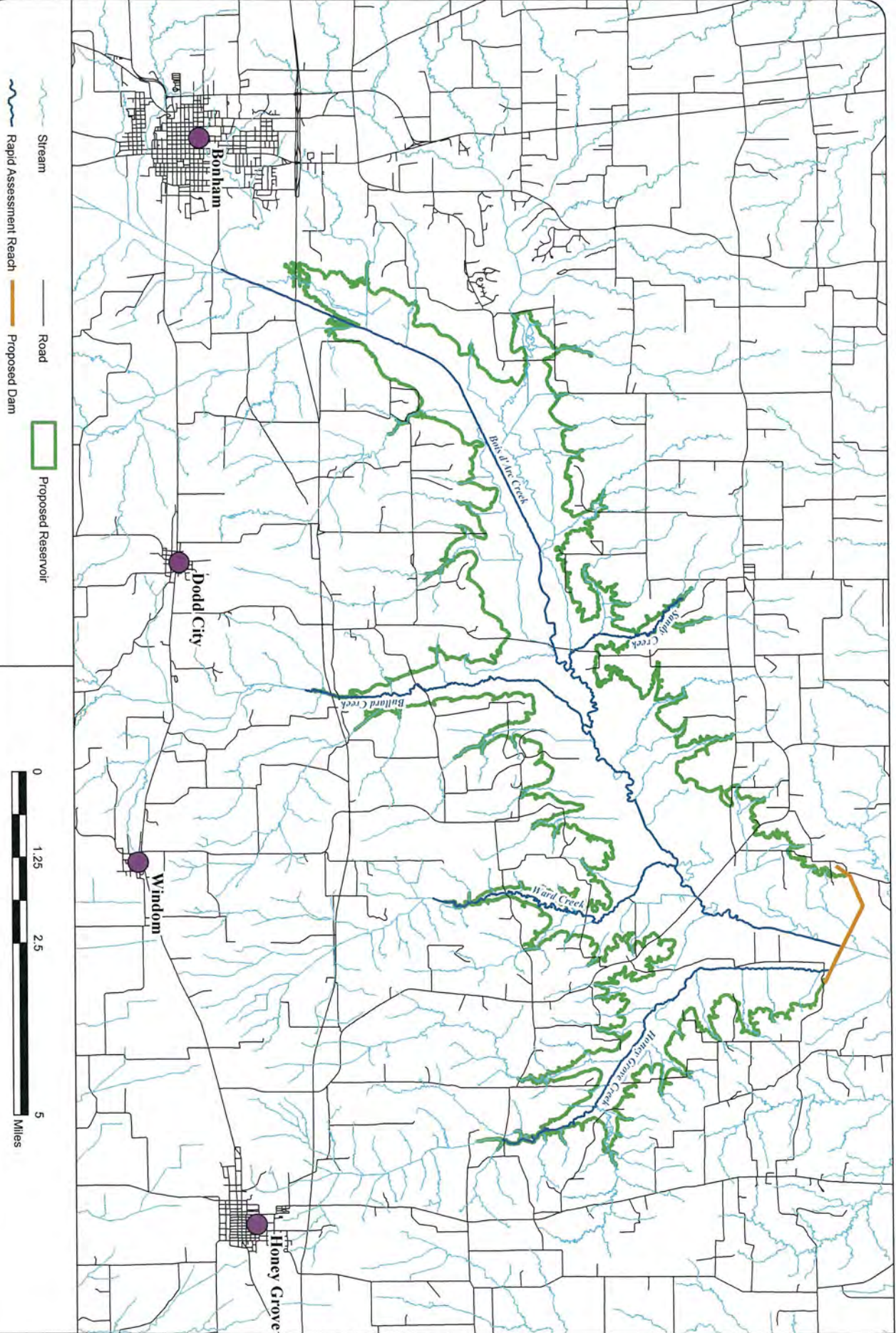

Date: Tuesday, September 02, 2008 1:06 PM

Prepared By: jm

File: H:\STORMWATER\FINAL_EXHIBITS\FIGES01_Location.mxd



FIGURE
ES-1

Freesee and Nichols
10814 Jollyville Road
Building 4, Suite 100
Austin, TX 78759
Phone: (512) 617-3100
Fax: (512) 617-3101

North Texas Municipal Water District
Proposed Lower Bois d'Arc Reservoir Project
Location

PROJECT NO.	ABC07989
DATE	September 2008
DATUM & COORDINATE SYSTEM	NAD83 State Plane TX Central
FILE	Fig1of_Location.mxd
PREPARED BY	jm

Objectives

The primary objective of this study is to perform a rapid geomorphic stability assessment of Bois d'Arc Creek and four major tributaries (Honey Grove Creek, Sandy Creek, Ward Creek, and Bullard Creek) within the inundation pool of the proposed reservoir. The results of this rapid assessment will be used in conjunction with the environmental report and habitat assessment developed by Freese and Nichols, Inc. (FNI) to describe the existing conditions of the riverine system. The rapid geomorphic assessment will be based on general stream stability, riparian vegetation, and potential for instream habitat.

This assessment is the first step to further studies that will be required for instream flow determinations, sediment transport analysis, and eventually evaluating downstream mitigation and restoration opportunities. The results of this study will be used to classify the study reaches as good, fair, or poor for use in conjunction with the environmental report, habitat assessment, and 404 permit application to aide in describing the existing conditions of the riverine system upstream of the dam.

Methodology

The existing physical characteristics of the main stem of Bois d'Arc Creek and its major tributaries were developed using a combination of field collected data, current one-foot LIDAR generated topography, current two-foot aerial topography, and both current and historic aerial photography/mapping. The channel classification procedure used for this phase of analysis is based on a rapid assessment of the stream geomorphic properties and characteristics of the main stem of Bois d'Arc Creek (upstream of the proposed dam) and four (4) major tributaries: Honey Grove Creek, Ward Creek, Bullard Creek, and Sandy Creek.

The rapid assessments were based on both anthropogenic and natural factors observed in the field and through comparison of the existing and historic channel pattern and geometry.

Four forms were used to complete the Rapid Assessment at each site. The Data Collection Form was used to collect general stream information related to channel size and location. Specific data included channel geometry, identification of substrate material, identification of debris jams or blockages, identification of potential in-stream cover, and information regarding the riparian zone. The Bank Stability Form was used to record bank geometry, information regarding riparian vegetation and rooting depths, and general bank armoring. The Channel Stability Form was used to collect a variety of information related to the condition of the upper

slopes, lower slopes, and channel bed. Data collected on the field forms were consolidated into a Rapid Assessment Classification Form.

The data collected for the preliminary assessment include general, quantitative parameters as well as qualitative measurements of physical geomorphic features. The parameters utilized for this assessment were selected after review of multiple rapid assessment and data collection worksheets and selecting the parameters appropriate for this level of the stream assessment. Sources for selecting appropriate parameters included the "Watershed Assessment of River Stability & Sediment Supply" (Rosgen, 2006), "Texas Instream Flow Studies: Technical Overview" (TWDB, 2008), "Montgomery County Rapid Stream Assessment Technique" (Montgomery County, 1992), and the "Vermont Rapid Stream Assessment" (Vermont, 2007).

Channel Evolution

Based on field observations of Bois d'Arc Creek and the studied tributaries, the morphological adjustments of each creek can be described using a general incised channel evolution model. A number of studies of incised channels in alluvial materials in the United States have shown that following channelization, the altered channel geometry changes through a predictable sequence of channel evolution. (Ireland et al., 1939; Schumm et al., 1984; Harvey and Watson, 1986; Simon and Hupp, 1986; Simon, 1989). These channel evolution sequences / models provide a method for interpreting the current stage of the channel morphology by evaluating the existing channel form and geomorphic processes.

The channel evolution model identifies the stages of channel form beginning with the channelized section, which disrupts the dynamic equilibrium, through major stages of disequilibrium and channel evolution back to a state of dynamic equilibrium. The model shows the channel to incise, then widen as a result of bank failure and mass wasting. As the channel becomes over-widened it will begin to aggrade because the stream power will be insufficient to carry the existing sediment load. Eventually a new channel will form within the over-widened section with sufficient stream power to carry the total sediment supply and a new dynamic equilibrium will be reached.

Based on the rapid assessment of Bois d'Arc Creek and the four studied tributaries, all of the reaches have been impacted and none of the reaches have reached a new state of dynamic

equilibrium; however, there are reaches in which new channels are beginning to form within the over-widen channels and the creek is in the process of recovering.

Conclusions

Table ES.1 summarizes the results of the rapid assessment reaches analyzed for the Rapid Geomorphic Assessment.

- The majority of Bois d'Arc Creek (54%) was classified as "poor" with the remainder (46%) being classified as "fair."
- The majority of Honey Grove Creek (86%) was classified as "fair" with the remainder being classified as "good" (8%) or "poor" (6%).
- The majority of Ward Creek (84%) was classified as "fair" with the remainder (16%) being classified as "poor."
- The majority of Bullard Creek (82%) was classified as "poor" with the remainder (18%) being classified as "fair."
- The majority of Sandy Creek (83%) was classified as "poor" with the remainder (17%) being classified as "fair."

**Table ES.1
Channel Classification**

Name	Classification	Reach Length (ft)	Percentage
Bois d'Arc Creek Reach 1	Total Reach	7,000	100%
	Good	-	0%
	Fair	3,587	51%
	Poor	3,413	49%
Bois d'Arc Creek Reach 2	Total Reach	12,000	100%
	Good	-	0%
	Fair	5,419	45%
	Poor	6,581	55%
Bois d'Arc Creek Reach 3	Total Reach	5,000	100%
	Good	-	0%
	Fair	50	1%
	Poor	4,950	99%
Bois d'Arc Creek Reach 4	Total Reach	24,500	100%
	Good	-	0%
	Fair	17,084	70%
	Poor	7,416	30%
Bois d'Arc Creek Reach 5	Total Reach	40,800	100%
	Good	-	0%
	Fair	15,200	37%
	Poor	25,600	63%
Bois d'Arc Creek Total	Total Reach	89,300	100%
	Good	-	0%
	Fair	41,340	46%
	Poor	47,960	54%
Honey Grove Creek	Total	35,700	100%
	Good	2,700	8%
	Fair	30,700	86%
	Poor	2,300	6%
Ward Creek	Total	27,900	100%
	Good	-	0%
	Fair	23,500	84%
	Poor	4,400	16%
Bullard Creek	Total	25,900	100%
	Good	-	0%
	Fair	4,600	18%
	Poor	21,300	82%
Sandy Creek	Total	14,150	100%
	Good	-	0%
	Fair	2,400	17%
	Poor	11,750	83%

Rapid Geomorphic Assessment of Bois d'Arc Creek and its Tributaries for the Lower Bois d'Arc Creek Reservoir Project

1.0 Introduction

The North Texas Municipal Water District (NTMWD) is proposing to build an approximately 367,600 acre-foot water supply reservoir (Lower Bois d'Arc Creek Reservoir) on Bois d'Arc and Honey Grove Creeks approximately 15 miles northeast of Bonham in Fannin County, Texas (Figure 1.1). Bois d'Arc Creek and its tributaries, upstream of the proposed reservoir, are incised and eroding. Current conditions of the creeks are the result of channelization and straightening of the natural, meandering creeks and loss of vegetation along bank slopes due to agricultural (farming and ranching) practices.

The primary objective of this study is to perform a rapid geomorphic assessment of Bois d'Arc Creek and four major tributaries (Honey Grove Creek, Sandy Creek, Ward Creek, and Bullard Creek) within the inundation pool of the proposed reservoir. The results of this preliminary geomorphic assessment will be used in conjunction with the environmental report and habitat assessment developed by Freese and Nichols, Inc. (FNI) to describe the existing conditions of the riverine system. The geomorphic assessment will be based on general stream stability, riparian vegetation, and the potential for developing aquatic habitat features.

This assessment is similar to Step 1 of the "Texas Instream Flow Studies: Technical Overview (TWDB, 2008) and is the first step to further studies that will be required for instream flow determinations and eventually evaluating mitigation and restoration. The results of this study will be used to classify the study reaches as good, fair, or poor for use in the 404 permit application to help describe the existing conditions of the riverine system.

Data and information used in this investigation included:

- Mapping / Aerial Photography from 1915, 1950, 1970, and 2007
- 1-foot LIDAR data from January 2007
- 2004 2-foot aerial contour data from Dallas Aerial Survey
- Geologic Maps of Texas
- Soil Survey of Fannin County
- Field Data (Section 4.0 Methodology)

A description of how this information was applied to the analysis is described in Section 4.0 Methods.

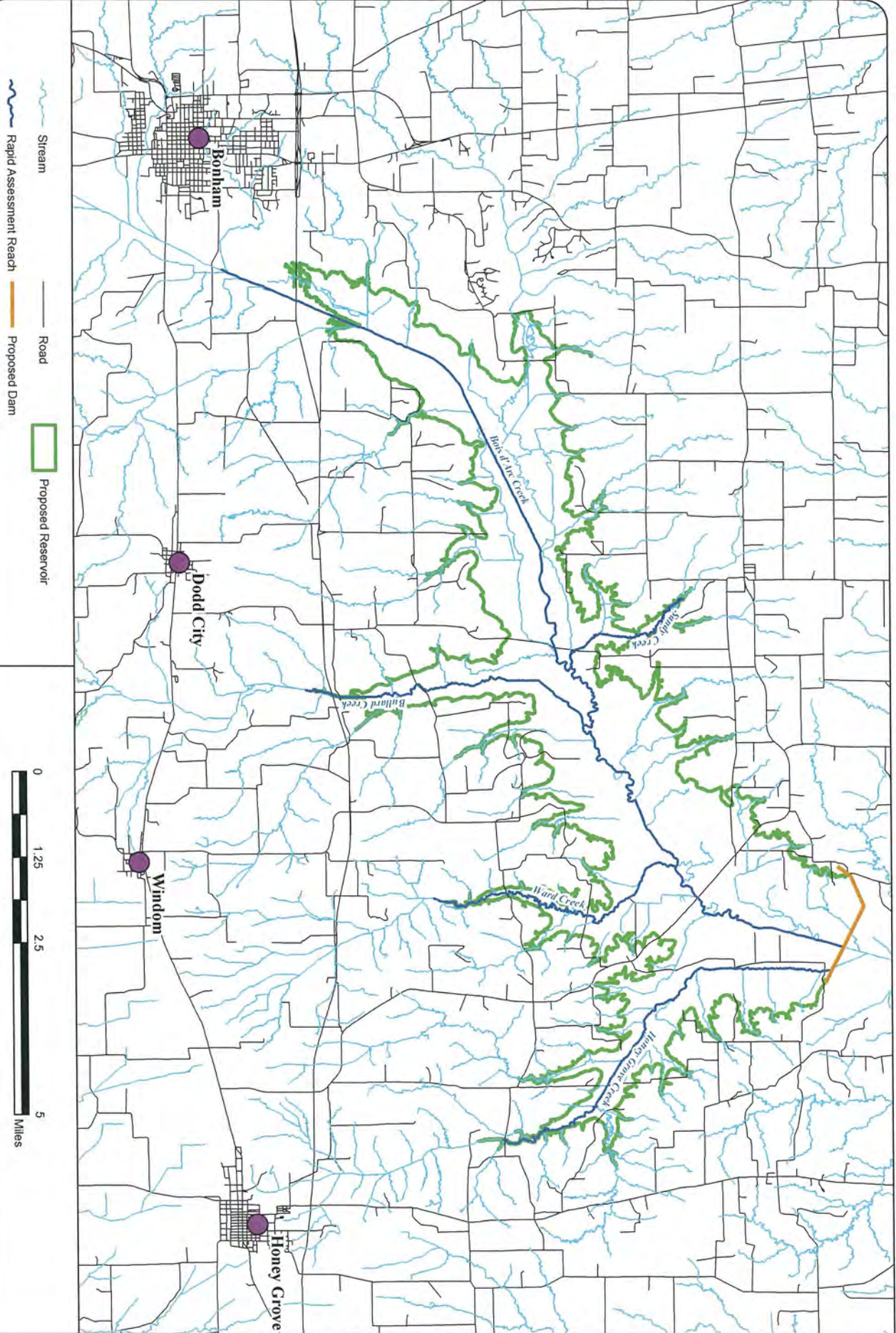

Date: Tuesday, September 02, 2008 1:06 PM

Prepared By: jm

File: H:\STORMWATER\FINAL_EXHIBITS\Fig101_Location.mxd



FIGURE
1.1

Freese and Nichols
10814 Jollyville Road
Building 4, Suite 100
Austin, TX 78759
Phone: (512) 617-3100
Fax: (512) 617-3101

North Texas Municipal Water District
Proposed Lower Bois d'Arc Reservoir Project
Location



PROJECT NO.	ABC07999
DATE	September 2008
DATUM & COORDINATE SYSTEM	NAD83 State Plane TX Central
FILE	Fig101_Location.mxd
PREPARED BY	JM

2.0 Basin History

2.1 Ecoregions

The proposed Lower Bois d'Arc Creek Reservoir is located in two Level IV ecoregions as mapped and described by Griffith et. al. (2004). The southern portion of the reservoir and the associated streams are in the Northern Blackland Prairie Ecoregion (Level IV) of the Texas Blackland Prairies (Level III), while the northern portion is in the Northern Post Oak Savannah (Level IV) Ecoregion within the East Central Texas Plains region (Level III) (Figure 2.1). Beginning approximately six miles downstream of the proposed dam site, Bois d'Arc Creek flows through the Pleistocene Fluvial Terraces (Level IV) of the South Central Plains Ecoregion (Level III) and eventually converges with the Red River in the Red River Bottomlands (Level IV) of the South Central Plains Ecoregion.

This diverse ecological, including topographical, soil, and geological characteristics, influences the vegetation, wildlife, and hydrological characteristics of the area. An understanding of these features can help put the results of the geomorphic assessment of stream condition into regional context.

The Northern Blackland Prairie Ecoregion encompasses most of Honey Grove Creek, Ward Creek, Bullard Creek, and the upstream portion of Bois d'Arc Creek. The soils of this ecoregion are characterized by mostly fine-textured, dark, calcareous, and productive Vertisols. These soils are underlain by interbedded chinks, marls, limestones, and shales of the Cretaceous age.

The northern part of Lower Bois d'Arc Creek Reservoir, Sandy Creek and other tributaries entering Bois d'Arc Creek to about six miles downstream of the proposed dam are within the Northern Post Oak Savannah Ecoregion. This region is characterized by fine textured loam soils with a udic moisture regime, underlain mostly by Eocene and Paleocene-age formations.

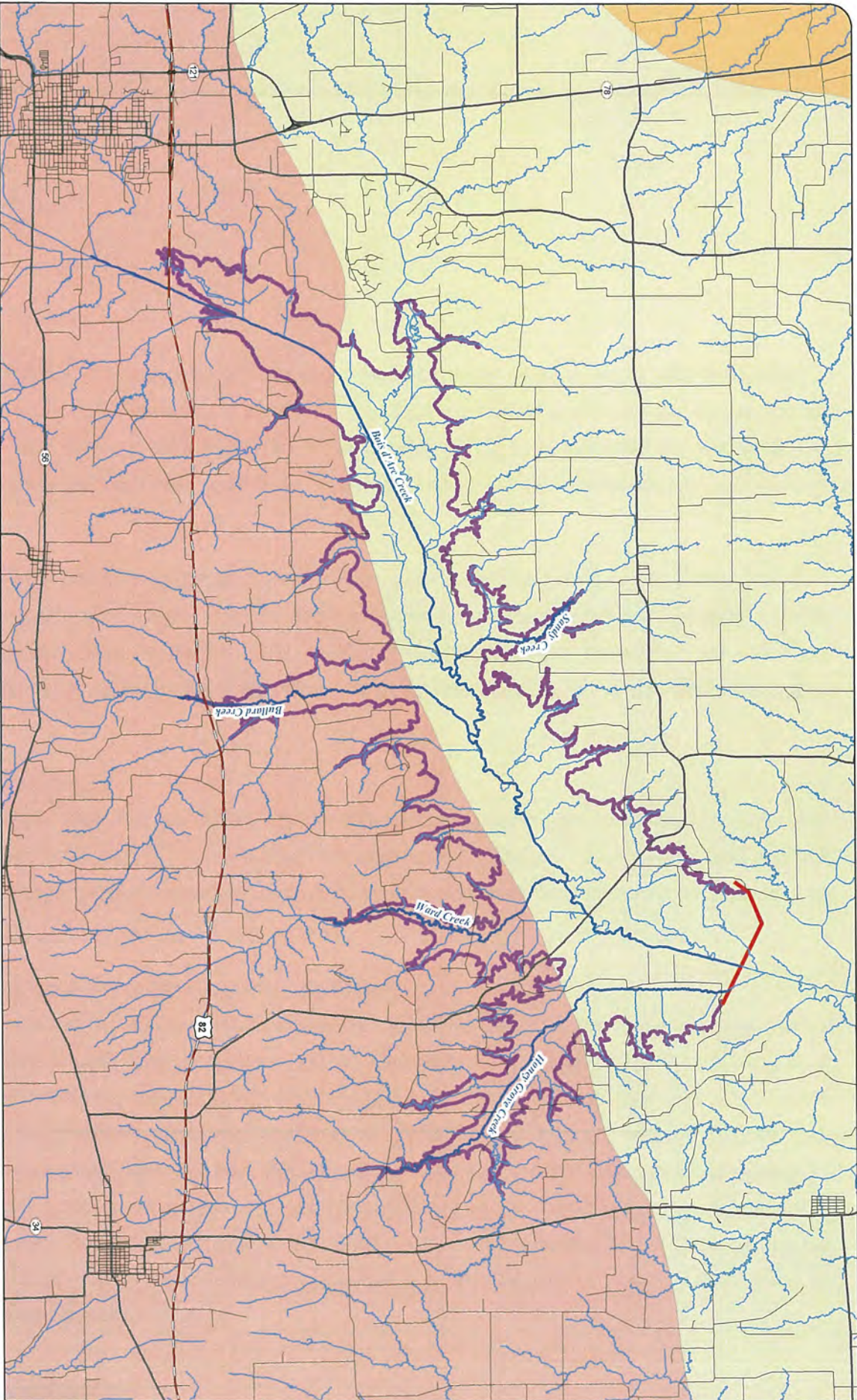

- Texas Eco-Regions**
- Northern Blackland Prairie
 - Northern Post Oak Savanna
 - Pleistocene Fluvial Terraces
- Rapid Assessment Reach**
-
- Stream**
-
- Proposed Dam**
-
- Proposed Reservoir**
-



Date: Tuesday, September 02, 2008 12:57 PM
 Prepared By: jm
 File: H:\STORMWATER\FINAL_EXHIBITS\Fig201_EcoRegions.mxd

FIGURE
2.1

Frese and Nichols
 10814 Jollyville Road
 Building 4, Suite 100
 Austin, TX 78759
 Phone: (512) 617-3100
 Fax: (512) 617-3101

North Texas Municipal Water District
Proposed Lower Bois d'Arc Reservoir Project
Eco-Regions



PROJECT NO.	NTD06128
DATE	September 2008
DATUM & COORDINATE SYSTEM	
NA83 State Plane TX Central	
FILE	Eco_Regions.mxd
PREPARED BY	JM

2.2 Geologic Setting

The stream channel patterns and characteristics of the Bois d'Arc system are greatly influenced by the geologic lithology and structure occurring in Fannin County (Figure 2.2). In general, the streams and creeks in Fannin County, including Bois d'Arc Creek, flow in channels cut through alluvium and fluvial terrace deposits which were deposited by larger streams during the Pleistocene and Holocene Epochs of the Quaternary Period (USDA, 2001). The alluvial deposits in the channels of Bois d'Arc Creek, Sandy Creek, Bullard Creek, Ward Creek, and Honey Grove Creek were derived from Upper Cretaceous bedrock which lies directly beneath the alluvium (USDA, 2001). This Upper Cretaceous bedrock is also visible at the surface on either side of the respective stream channels (BEG, 1967).

The Upper Cretaceous bedrock visible along Bois d'Arc Creek formed in shallow seas that extended inland from the Gulf of Mexico. All of the originally flat-lying strata now strikes east-northeast and dips south-southeast at a rate of approximately 30 to 35 feet per mile (USDA, 2001). However, the dip rate increases to 300 feet per mile on the southeastward-plunging ridge of the Preston Anticline (TDWR, 1982). The Preston Anticline is a broad arch located in the western portion of Fannin County that trends northwest-southeast and plunges southeastward. Due to the presence of this structure, bedrock, stream channels, and soils are deflected southeastward as they pass over the axis of the anticline (TDWR, 1982; USDA, 2001).

The surficial deposits on the northwestern side of Bois d'Arc Creek, and along Sandy Creek and portions of Honey Grove Creek, consist of poorly to thinly bedded silty marl and waxy clay of the Bonham Marl of the Austin Group (BEG, 1967; USDA, 2001). The marl has a maximum thickness of approximately 400 feet and weathers to yellowish green at its type locality (USDA, 2001). The marl becomes increasingly calcareous as it continues westward and merges with the undivided Austin Chalk in Grayson County (USDA, 2001). Eastward, it is less calcareous and becomes increasingly marly. The surface of the Bonham Marl outcrop is a gently rolling plain (USDA, 2001).

The formations visible on the southeastern side of Bois d'Arc Creek, and along Bullard Creek, Ward Creek, and portions of Honey Grove Creek, are the Blossom Sand and the Brownstone Marl of the Austin Group. The Blossom Sand typically consists of very fine-grained to fine-grained, calcareous, ferruginous quartz sand that grades westward into clay (BEG, 1967;

USDA, 2001). The Blossom Sand outcrop in Fannin County ranges from 0.25 mile to 2.75 miles in width, and weathers to brown and red at the surface (USDA, 2001). The Blossom Sand is approximately 20 feet thick, but thickens eastward and feathers out westward. The sand eventually merges with the Bonham Marl, east of the City of Bonham (BEG, 1967; USDA, 2001). On the surface, the Blossom Sand is a gently rolling plain with broad divides between stream valleys (USDA, 2001).

The Brownstone Marl of the Austin Group outcrops to the south of the Blossom Sand on the southeastern side of Bois d'Arc Creek, and along Bullard Creek, Ward Creek, and portions of Honey Grove Creek. The Brownstone Marl typically consists of medium yellowish grey, poorly bedded, calcareous marl and clay with glauconite present at the base of the marl (BEG, 1967; USDA, 2001). The marl ranges in thickness from 80 to 175 feet, but feathers out westward near the City of Bonham where it merges with the Bonham Marl; eastward, the Brownstone Marl thickens (USDA, 2001). The Brownstone Marl outcrop is roughly 1.5 to 4.0 miles wide in Fannin County. It is very susceptible to water erosion and mass wasting, and the weathered outcrop tends to be light yellowish grey in color (USDA, 2001). The outcrop of the Brownstone Marl is dissected by several stream channels, and only a few flat surfaces are present between the stream channels (USDA, 2001).

2.3 Soils

The mainstem of Bois d'Arc Creek from upstream of Bonham and downstream to about three miles above the confluence with the Red River traverses the Tinn soil series (Soil Survey of Fannin County, Texas, United States Department of Agriculture, 1988). This series consists of moderately well drained, very slowly permeable, clayey soils on floodplains. The series has a "very high" shrink swell potential and an *Erosion factor K* value of 0.32.

Tributaries flowing into the proposed Bois d'Arc Creek Reservoir on the north side upstream of Sandy Creek flow through the Normangee-Wilson-Bonham series group (Soil Survey of Fannin County, Texas, United States Department of Agriculture, 1988) consisting of loamy and clayey, moderately acid to neutral soils. Normangee and Bonham series have moderate to high shrink swell potential and an *Erosion factor K* ranging from 0.31-0.37, while the Wilson series has low to high shrink swell and an *Erosion factor K* ranging from 0.37-0.43.

From approximately the mouth of Sandy Creek to near FM 100 downstream of the proposed dam soils adjacent to the floodplain Tinn series are in the Whakana-Porum-Freestone series (Soil Survey of Fannin County, Texas, United States Department of Agriculture, 1988) that are loamy, very strongly acid to neutral soils on terraces. Freestone series has low to high shrink swell potential and an *Erosion factor K* ranging from 0.32-0.37; the Porum series has low to high shrink swell and an *Erosion factor K* ranging from 0.32-0.43; and the Whakana series has low to moderate shrink swell and an *Erosion factor K* of 0.32.

On the south side of the proposed reservoir, Honey Grove, Bullard, and Sloans creeks are in the Frioton series (Soil Survey of Fannin County, Texas, United States Department of Agriculture, 1988) that is clayey and loamy, moderately alkaline soils on floodplains. This series has a high shrink swell potential and an *Erosion factor K* of 0.32.

The majority of the remaining drainages on the south side of the reservoir consist of the Ellis-Crockett series (Soil Survey of Fannin County, Texas, United States Department of Agriculture, 1988) of loamy and clayey, moderately acid to neutral soils on uplands. The Crockett series has low to high shrink swell potential and an *Erosion factor K* ranging from 0.32-0.43 and the Ellis series has high shrink swell potential and an *Erosion factor K* ranging from 0.32.

2.4 Historical Land Use Practices

According to a historical map dated circa 1915 and aerial photography dated 1950, 1970, and 2005, the land surrounding the Bois d'Arc Creek system remains largely undeveloped, rural land predominantly used for agricultural purposes. There is evidence by the historical data that landowners have modified the terrain by digging drainage channels through their property, bypassing and sometimes abandoning the natural riverine system. This channelization has resulted in the creeks incising, causing down cutting of the channel bottom throughout the reaches.

Due to crop rotation or change of land owners throughout the area, the riparian vegetation buffer alongside the creeks is constantly changing. According to the 1950 aerial, it was common to see a 2,000 to 4,000 foot vegetative buffer around Bois d'Arc Creek; but over time, the buffer has come closer to the channel. In some areas the vegetation has been cleared up to the creek banks, which in turn causes bank instability due to the loss of rooting mass.

However, on Honey Grove, Bullard, and Ward Creeks on the south side of Bois d'Arc Creek, the buffer has increased over time. Referencing the 1950 aerial, very rarely was there vegetation on both sides of the creek and the vegetation that was there was no more than 50 feet wide. The 2007 aerials show that due to changes in agricultural practices (i.e. clearing up to the stream banks) the vegetative buffer along these creeks has increased from almost nothing to more than 500 feet wide with only short reaches of stream where the clearing extends to the creek.

On the north side of Bois d'Arc Creek, the vegetation buffer along Sandy Creek has remained fairly constant over the last 50 years.

For a description of specific historical changes for each reach, refer to Section 5.0 in this report.

3.0 Incised Channel Evolution Model

Significant portions of the Bois d'Arc Creek system was channelized over the years, with some alterations to the natural stream channel occurring before 1915. Based on historical aerial photographs, stream channelization continued within the Bois d'Arc Creek system into the 1970's. As part of the assessment of the quality of the current Bois d'Arc Creek system, it is important to know if the system has re-established equilibrium since the time it was channelized and the riparian vegetation buffer has changed. Determining the state of the channel is therefore a function of determining if the channel is in dynamic equilibrium or if the sediment supply and stream power are still out of balance. A number of studies of incised channels in alluvial materials in the United States have shown that following channelization, the altered channel geometry changes through a predictable sequence of channel evolution. (Ireland et al., 1939; Schumm et al., 1984; Harvey and Watson, 1986; Simon and Hupp, 1986; Simon, 1989). These channel evolution sequences / models provide a method for interpreting the current stage of the channel morphology by evaluating the existing channel form and geomorphic processes. The evolution model also provides a means for predicting future channel evolution / channel processes.

The five stage Incised Channel Evolution Model (ICEM), developed by Schumm, Harvey and Watson (1984) describes the evolution of a channelized stream or river and was applied to this analysis to describe the conditions of the Bois d'Arc Creek system. The changes in channel geometry resulting from channelization will extend upstream and downstream from the altered reach as the stream system works to re-establish dynamic equilibrium. The effects of channelization can impact tributaries that are forced to adjust through down cutting and erosion to re-attain equilibrium.

The channel evolution model shown as Figure 3.1 identifies the stages of channel form beginning with the channelized section, which disrupts the dynamic equilibrium, through major stages of disequilibrium and channel evolution back to a state of dynamic equilibrium. As shown, the channel incises then widens as a result of bank failure and mass wasting. As the channel becomes over-widened it will begin to aggrade because the stream power will be insufficient to carry the existing sediment load. Eventually a new channel will form within the over-widened section with sufficient stream power to carry the total sediment supply and a new dynamic equilibrium will be reached.

TYPE I ($h < h_c$)
CHANNELIZED

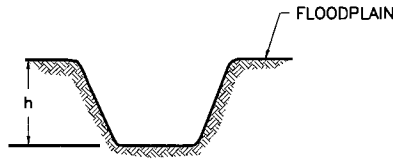

TYPE II ($h < h_c$)
DEGRADATION

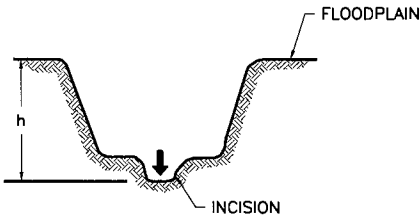

TYPE III ($h > h_c$)
WIDENING

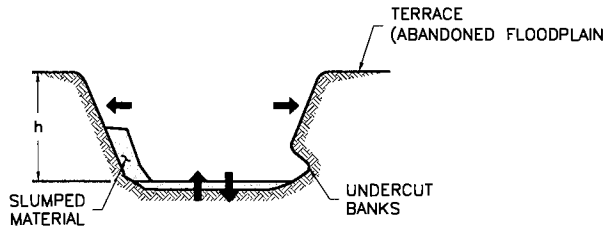

TYPE IV ($h > h_c$)
WIDENING AND
AGGRADATION

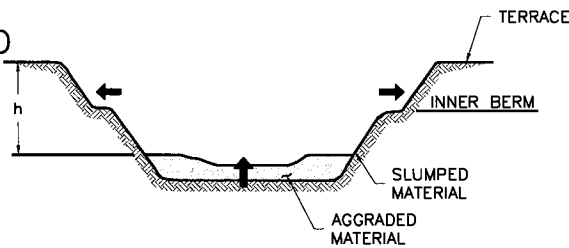

TYPE V ($h < h_c$)
DYNAMIC
EQUILIBRIUM

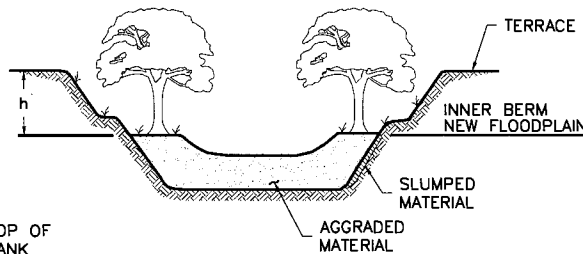

LONGITUDINAL
PROFILE

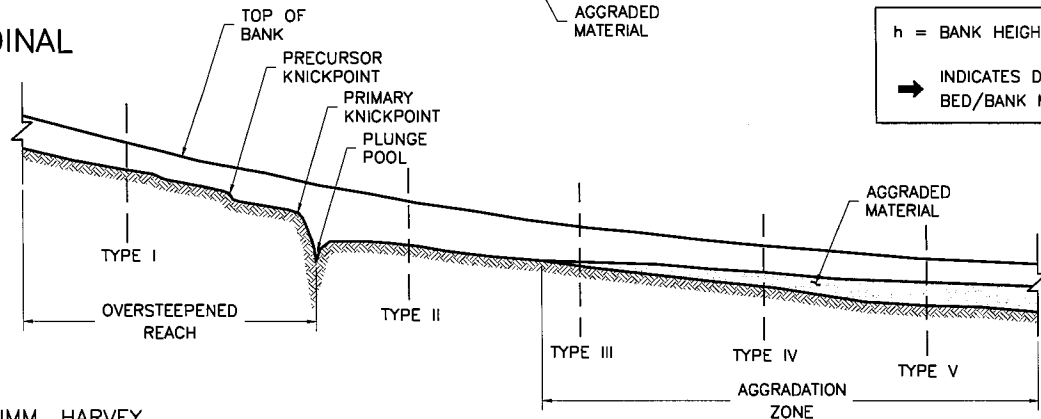

REFERENCE: SCHUMM, HARVEY
AND WATSON (1984)

User: GAL
 REPORT FIGURE 3.DWG LAYOUT: Layout1
 M. L.T.S.: 1.00 P.S.L.T.S.: 1.00
 ACAD Ref: 17.1s (LMS)
 (NTD06128) (AUSTIN)
 JAN. 28, 2008 2:28pm



NORTH TEXAS MUNICIPAL WCID
LOWER BOIS D'ARC CREEK PROPOSED RESERVOIR PROJECT

FLUVIAL GEOMORPHOLOGY
INCISED CHANNEL EVOLUTION PROCESS

F&N JOB NO.	NTD06128
DATE	JAN. 2008
SCALE	N.T.S.
DESIGNED	JWS
DRAFTED	GAL
FILE	Figure 3.dwg

3.1

FIGURE

The characteristics of the five stages of the channel evolution model and the morphological adjustments of the channel through time can be summed up as follows:

- Type I – channel upstream of channel incision, prior to morphological adjustments
- Type II – actively incising but the banks are stable (no mass wasting)
- Type III – rapidly widening channel due to undercutting and mass wasting of banks, signs of some aggradation are apparent due to excess sediment load and over widened channel
- Type IV – channel widening continues but at a reduced rate, signs that recovery has begun to emerge in the form of inner berms and emergent vegetation
- Type V – dynamic equilibrium re-established, new stable channel formed within the old channel with new floodplain, old floodplain becomes an abandoned terrace.

This model explains the general morphology of the Bois d’Arc Creek system. Bois d’Arc Creek and portions of its tributaries have been altered and, as expected, the channelized sections are following the predicted channel evolution. A similar sequence of channel evolution has been observed on Mill Creek, a tributary of Chambers Creek in the Blackland Prairie Region of Texas (Allen, 2006). The North Sulphur River and tributaries exhibited a similar channel evolution sequence while the channels were located in alluvium but became more complicated when the underlying shale was exposed (Mussetter Engineering, 2006).

The application of the channel evolution model to the Bois d’Arc Creek system within the project area is one component of the rapid assessment used for this study. Further discussions of the channel evolution types by stream reach are presented in Section 5.0.

As stated above, an important aspect of this assessment is making a preliminary determination as to whether or not the Bois d’Arc Creek system is in dynamic equilibrium. One of the major impacts of disequilibrium is that the reaches will, at best, provide only transitory habitat features and have little, if any, permanent habitat features. Previous studies have indicated that channelized streams in the humid, southwest United States can take forty to fifty years to complete the channel evolution process (Schumm et Al. 1984; Schumm 1999; Simon 1989); however, channelized streams in the semi-arid southwest can take more than 100 years to complete the cycle (Gellis et al., 1995).

4.0 Methods

This section describes the rapid assessment protocols and methods utilized to assess individual stream segments. The existing physical characteristics of the mainstem of Bois d'Arc Creek and the major tributaries were developed using a combination of field collected data, current one-foot LIDAR generated topography, current two-foot aerial topography, and both current and historic aerial photography/mapping. The channel classification procedure used for this phase of analysis is based on a rapid assessment of the stream geomorphic properties and characteristics of the main stem of Bois d'Arc Creek and four (4) major tributaries: Honey Grove Creek, Ward Creek, Bullard Creek, and Sandy Creek.

The rapid assessments were based on both anthropogenic and natural factors observed in the field and through comparison of the existing and historic channel pattern and geometry. The major factors evaluated were channel stability, vegetation/armoring, and potential in-stream habitat features. A brief description of the components used to develop the rapid stream assessments is presented below.

4.1 Field Collected Data

Freese and Nichols collected data at 82 sites throughout the riverine system (Figure 4.1). Table 4.1 provides a list of the data points and coordinates.

Three forms were used to record information at each site. The Data Collection Sheet (Figure 4.2) includes general stream information related to channel size and location. Specific data includes channel geometry, identification of substrate material, identification of debris jams or blockages, identification of potential in-stream cover, and information regarding the riparian zone. The Bank Stability form (Figure 4.3) was used to record general bank geometry, information regarding riparian vegetation and rooting depths, and general bank armoring. The Channel Stability form (Figure 4.4) was used to collect a variety of information related to the condition of the upper slopes, lower slopes, and channel bed. Data collected on the field forms were consolidated into a Rapid Assessment Classification Sheet for each data point as discussed in Section 4.3 of this report.

The data collected for the preliminary assessment include general, quantitative parameters as well as qualitative measurements of physical geomorphic features. The parameters utilized for this assessment were selected after reviewing multiple rapid assessment and data collection worksheets and selecting the parameters appropriate for this level of the stream assessment.

Sources for selecting the parameters included the “Watershed Assessment of River Stability & Sediment Supply” (Rosgen, 2006), “Texas Instream Flow Studies: Technical Overview” (TWDB 2008), “Montgomery County Rapid Stream Assessment Technique” (Montgomery County, 1992), and the “Vermont Rapid Stream Assessment” (Vermont, 2007).

There were several sites where FNI was unable to access the creeks due to the steep terrain of the channel banks or property access. For these sites, FNI relied on visual inspection from the upper banks or the road crossing.

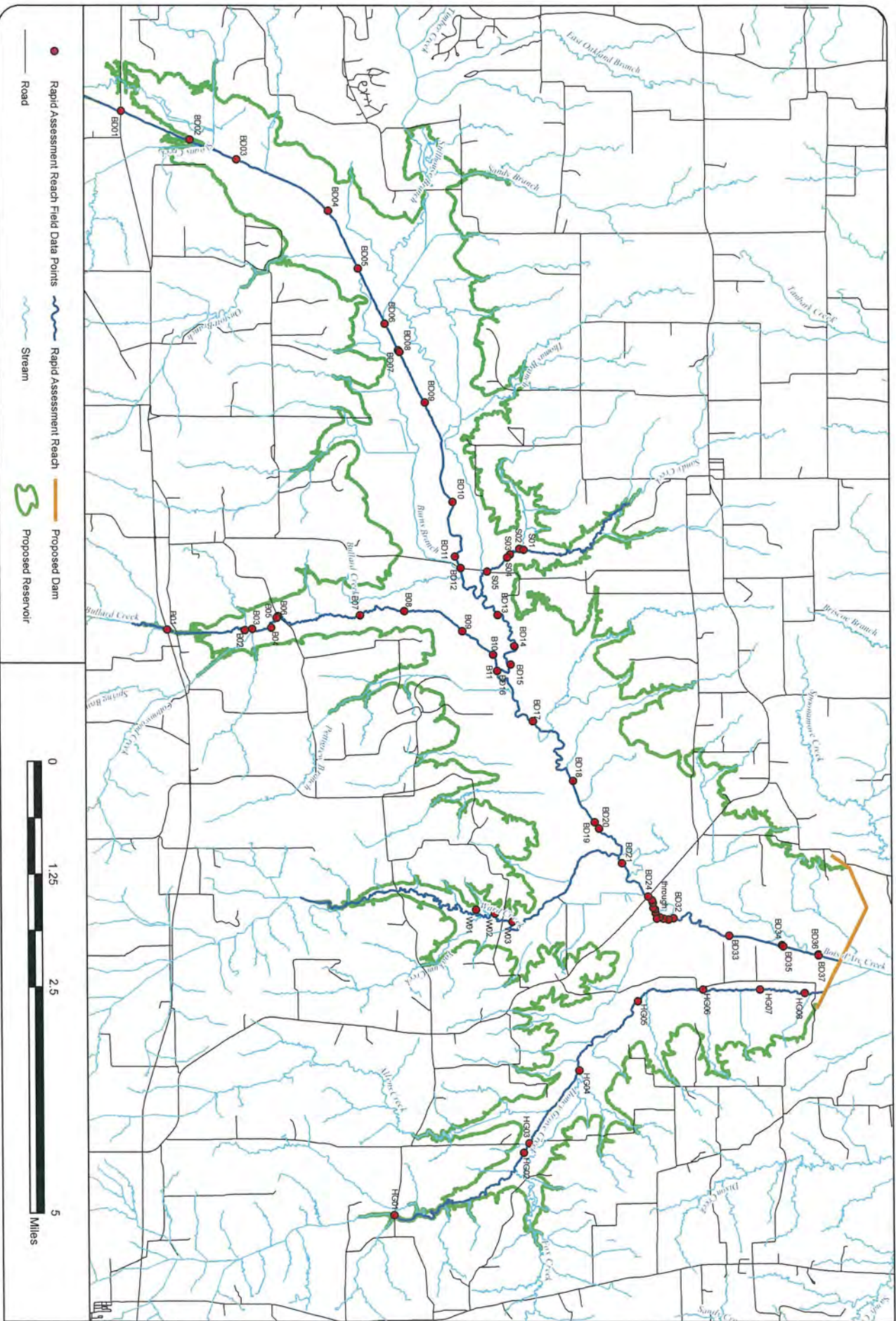

Date: Tuesday, September 02, 2008 1:10 PM
 Prepared By: jm
 File: H:\STORMWATER\FINAL_EXHIBITS\Fig401_DataPts.mxd



FIGURE
4.1



North Texas Municipal Water District
Proposed Lower Bois d'Arc Reservoir Project
Data Collection Points



FIN PROJECT NO	ASBC07999
DATE	September 2008
DATUM & COORDINATE SYSTEM	NAD83 State Plane TX Central
FILE	Fig401_DataPts.mxd
PREPARED BY	JM

Table 4.1 - Field Data Points

Stream Reach	Point Label	Northing	Easting	Stream Reach	Point Label	Northing	Easting
Bois d'Arc	BD01	7,274,144.27	2,687,002.14	Bullard	B01	7,276,285.80	2,717,369.59
Bois d'Arc	BD02	7,278,145.35	2,688,752.73	Bullard	B02	7,280,798.40	2,717,458.22
Bois d'Arc	BD03	7,280,848.00	2,689,935.46	Bullard	B03	7,281,268.63	2,717,389.30
Bois d'Arc	BD04	7,286,143.28	2,693,018.75	Bullard	B04	7,282,358.63	2,717,328.56
Bois d'Arc	BD05	7,287,813.20	2,696,415.61	Bullard	B05	7,282,684.77	2,716,777.18
Bois d'Arc	BD06	7,289,326.22	2,699,647.41	Bullard	B06	7,282,766.22	2,716,671.38
Bois d'Arc	BD07	7,290,071.71	2,701,211.60	Bullard	B07	7,287,533.23	2,716,692.09
Bois d'Arc	BD08	7,290,142.81	2,701,312.31	Bullard	B08	7,290,103.56	2,716,491.78
Bois d'Arc	BD09	7,291,564.36	2,704,282.31	Bullard	B09	7,293,487.77	2,717,698.06
Bois d'Arc	BD10	7,293,088.93	2,710,119.18	Bullard	B10	7,295,273.67	2,719,113.00
Bois d'Arc	BD11	7,293,151.48	2,713,327.28	Bullard	B11	7,295,484.23	2,720,058.19
Bois d'Arc	BD12	7,293,475.68	2,714,007.43	Honey Grove	HG01	7,288,779.21	2,751,792.11
Bois d'Arc	BD13	7,295,576.73	2,716,776.36	Honey Grove	HG02	7,296,419.87	2,748,241.54
Bois d'Arc	BD14	7,296,516.49	2,718,637.33	Honey Grove	HG03	7,296,753.12	2,747,713.71
Bois d'Arc	BD15	7,296,295.79	2,719,705.30	Honey Grove	HG04	7,299,779.68	2,743,492.87
Bois d'Arc	BD16	7,295,484.23	2,720,058.19	Honey Grove	HG05	7,303,272.73	2,739,505.84
Bois d'Arc	BD17	7,297,520.65	2,723,040.78	Honey Grove	HG06	7,307,108.47	2,738,897.20
Bois d'Arc	BD18	7,299,766.05	2,726,561.16	Honey Grove	HG07	7,310,437.58	2,738,945.43
Bois d'Arc	BD19	7,300,987.41	2,729,020.00	Honey Grove	HG08	7,313,032.52	2,739,175.52
Bois d'Arc	BD20	7,301,225.30	2,729,391.76	Sandy	S01	7,297,191.01	2,712,996.32
Bois d'Arc	BD21	7,302,525.09	2,731,427.30	Sandy	S02	7,296,941.64	2,712,935.55
Bois d'Arc	BD22	7,304,013.76	2,733,411.89	Sandy	S03	7,296,374.77	2,713,254.50
Bois d'Arc	BD23	7,304,250.85	2,733,618.21	Sandy	S04	7,296,207.53	2,713,430.06
Bois d'Arc	BD24	7,304,281.60	2,733,790.57	Sandy	S05	7,295,013.26	2,714,221.97
Bois d'Arc	BD25	7,304,304.94	2,734,075.40	Ward	W01	7,293,948.00	2,734,035.92
Bois d'Arc	BD26	7,304,404.01	2,734,145.46	Ward	W02	7,295,040.70	2,734,273.39
Bois d'Arc	BD27	7,304,423.33	2,734,372.58	Ward	W03	7,296,053.00	2,734,758.27
Bois d'Arc	BD28	7,304,491.43	2,734,705.42				
Bois d'Arc	BD29	7,304,667.69	2,734,626.31				
Bois d'Arc	BD30	7,304,893.73	2,734,702.74				
Bois d'Arc	BD31	7,305,179.74	2,734,765.87				
Bois d'Arc	BD32	7,305,486.61	2,734,700.11				
Bois d'Arc	BD33	7,308,704.51	2,735,765.95				
Bois d'Arc	BD34	7,311,767.27	2,736,362.73				
Bois d'Arc	BD35	7,311,842.62	2,736,441.78				
Bois d'Arc	BD36	7,313,884.66	2,736,947.53				
Bois d'Arc	BD37	7,313,879.46	2,737,008.28				

Figure 4.2 – Data Collection Sheet

Data Collection Sheet				Sheet No.
Date:		Stream Name:		
Project Name:	Lower Bois d'Arc Creek Reservoir Phase II	Coordinates:		
Project Number:	NTD08128	Field Crew:		

Channel Characteristics:		Stream Size: Category (Bankfull Width, ft)			
Average Bank Width:	OHWL Width:	S-1 (<1)	<input type="checkbox"/>	S-6 (50-75)	<input type="checkbox"/>
Average Bank Depth:	Circle: Perennial, Intermittent, or Ephemeral	S-2 (1-5)	<input type="checkbox"/>	S-7 (75-100)	<input type="checkbox"/>
Average Stream Bed Depth:		S-3 (5-15)	<input type="checkbox"/>	S-8 (100-150)	<input type="checkbox"/>
Average Water Width:	Circle: Clear or Turbid	S-4 (15-30)	<input type="checkbox"/>	S-9 (150-250)	<input type="checkbox"/>
Average Water Depth:	Water Color:	S-5 (30-50)	<input type="checkbox"/>	S-10 (250-350)	<input type="checkbox"/>
Maximum Water Depth:					

Substrate:		Debris/Blockages:			*B.D.= Beaver Dams			
Silt/Clay	<input type="checkbox"/>	Boulder (>10")	<input type="checkbox"/>	D1: None	<input type="checkbox"/>	D5: Extensive	<input type="checkbox"/>	
Sand	<input type="checkbox"/>	Bedrock	<input type="checkbox"/>	D2: Infrequent	<input type="checkbox"/>	D6: Dominating	<input type="checkbox"/>	
Gravel (.25"-2.5")	<input type="checkbox"/>	Concrete	<input type="checkbox"/>	D3: Moderate	<input type="checkbox"/>	D7: B.D. - Few	<input type="checkbox"/>	
Cobble (2.5"-10")	<input type="checkbox"/>	Organic	<input type="checkbox"/>	D4: Numerous	<input type="checkbox"/>	D8: B.D. - Frequent	<input type="checkbox"/>	
							D9: B.D. - Abandoned	<input type="checkbox"/>
							D10: Human Influences	<input type="checkbox"/>

Instream Cover:			Riparian Zone:		
Undercut Banks	<input type="checkbox"/>	Deep Pools	<input type="checkbox"/>	Forest	<input type="checkbox"/>
Shallows	<input type="checkbox"/>	Overhanging Vegetation	<input type="checkbox"/>	Pasture	<input type="checkbox"/>
Boulders	<input type="checkbox"/>	Emergent/Submergent Vegetation	<input type="checkbox"/>	Paved	<input type="checkbox"/>
Oxbows	<input type="checkbox"/>	Logs/Brush	<input type="checkbox"/>	Old-Field/ROW	<input type="checkbox"/>
				Scrub/Shrub	<input type="checkbox"/>
				Row-Crop	<input type="checkbox"/>
				Residential	<input type="checkbox"/>
				Width of Riparian Zone	<input type="checkbox"/>

Riparian Vegetation:				
Category	Percent Aerial Cover	Percent Site Coverage	Species Composition	Percent of Total
Canopy Layer				
Shrub Layer				
Herbaceous				
Leaf or Needle Litter				
Bare Ground				

Photos:	Additional Notes:
---------	-------------------

Figure 4.3 – Bank Stability Form

BEHI Variable Worksheet

Stream: _____ Reach: _____ Cross Section: _____
 Observers: _____ Date: _____

Bank Height/Max Depth Bankfull (C)					BEHI Score
Study Bank Height (ft)	(A)	Bankfull Height (ft)	(B)	(A)/(B) = (C)	
Root Depth/Bank Height (E)					
Root Depth (ft)	(D)	Study Bank Height (ft)	(A)	(D)/(A) = (E)	
Weighted Root Density (F)					
Root Density (%)				(F)	
Bank Angle (G)					
Bank Angle (Degrees)				(G)	
Surface Protection (H)					
Surface Protection (%)				(H)	
Bank Material Adjustment					Bank Materials Adjustment
Bedrock (Overall Very Low BEHI) Boulders (Overall Low BEHI) Cobble (Subtract 10 points. If sand/gravel matrix greater than 50% of bank material, then do not adjust) Gravel (Add 5-10 points depending percentage of bank material that is composed of sand) Sand (Add 10 points) Silt Clay (no adjustment)					
Stratification Adjustment					
Add 5-10 points, depending on position of unstable layers in relation to bankfull stage					

VERY LOW	LOW	MODERATE	HIGH	VERY HIGH	EXTREME	ADJECTIVE RATING and TOTAL SCORE
5 - 9.5	10 - 19.5	20 - 29.5	30 - 39.5	40 - 45	46 - 50	

Bank Sketch

Figure 4.4 –Channel Stability Form

Pfankuch Channel Stability Form

Source:		Result:		Date:		Observer:		Comments:			
Location	Key	Category	Description	Rating	Good	Fair	Poor	Rating	Description		
Upper Banks	1	Uniform Slope	Bank slope gradient <30%.	2	Bank slope gradient 30-40%.	4	Bank slope gradient 40-50%.	6	Bank slope gradient 50%+.		
	2	Mass Wasting	No evidence of past or future mass wasting.	3	Frequent. Mostly headed over. Low future potential.	5	Frequent or large, causing sediment nearly year long OR Inclinant danger of same.	9	Frequent or large, causing sediment nearly year long OR Inclinant danger of same.		
	3	Debris Jam Potential	Essentially absent from immediate channel area.	2	Present, but mostly small logs and limbs.	4	Moderate to heavy amounts, mostly larger sizes.	6	Moderate to heavy amounts, predominantly larger sizes.		
	4	Vegetative Bank Protection	90%+ plant density. Vigor and variety suggest a deep, dense soil binding root mass.	3	70-90% density. Fewer species or less vigor suggest less dense or deep root mass.	5	50-70% density. Lower vigor and fewer species from a shallow, discontinuous root mass.	9	<50% density plus fewer species & less vigor indicating poor, discontinuous, and shallow root mass.		
Lower Banks	5	Channel Capacity	Area is far present plus some increase. Peak flows contained. (WD)/(WDO) < 1.1, BHR = 1.0 - 1.1	1	Adequate. Bank overflows are rare. (WD)/(WDO) = 1.1 - 1.2, BHR = 1.1 - 1.3	2	Excess capacity present. Occasional overbank flows. (WD)/(WDO) = 1.2 - 1.8, BHR = 1.3 - 1.5	3	Inadequate. Overbank flows common. (WD)/(WDO) > 1.8, BHR > 1.5		
	6	Bank Rock Content	50%+ w/ large angular boulders. 12" common.	2	40-65%. Mostly boulders and small cobbles 6-12".	4	20-40%. With most in the 3-6" diameter class.	6	<20% rock fragments of gravel sizes. 1-3" or less.		
	7	Obstructions to Flow	Rocks and logs firmly embedded. Flow pattern w/o cutting or deposition. Stable bed.	2	Some present causing erode cross currents and minor pool filling. Obstructions few; and less firm.	4	Moderately frequent, unstable obstructions move with high flows causing bank cutting and pool filling.	5	Frequent obstructions and deflections cause bank erosion yearlong. Sediment traps full, channel migration occurring.		
	8	Cutting	Little or none. Infrequent raw banks 6".	4	Some, intermittently at outer curves and constrictions. Raw banks may be up to 12".	6	Significant. Up to 12-24" high. Root mat overhangs and sloughing evident.	12	Almost continuous cuts, some over 24" high. Failure of overhangs frequent.		
Bottom	9	Deposition	Little or no enlargement of channel or point bars.	4	Some new bar increases, mostly from coarse gravel.	8	Moderate deposition of new gravel and coarse sand on old and some new bars.	12	Extensive deposit of predominantly fine particles. Accelerated bar development.		
	10	Rock Angularity	Sharp edges and corners. Paved surfaces rough.	1	Rounded corners and edges, surfaces smooth, flat.	2	Corner and edges well rounded in 2 dimensions.	3	Well rounded in all dimensions, surfaces smooth.		
	11	Brightness	Surfaces dull, dark or stained. Generally not bright.	1	Mostly dull, but may have <35% bright surfaces.	2	Mixture dull and bright, i.e. 35-65% mixture range.	3	Predominantly bright, 65%+, exposed or scoured surfaces.		
	12	Consolidation of Particles	Assorted sizes tightly packed or overlapping.	2	Moderately packed with some overlapping.	4	Mostly loose contact with no apparent overlap.	6	No packing evident. Loose assortment, easily moved.		
Bottom	13	Bottom Size Distribution	No size change evident. Stable material 60-100%.	4	Distribution shift light. Stable material 50-80%.	8	Moderate change in sizes. Stable materials 20-50%.	12	Marked distribution change. Stable materials 0-20%.		
	14	Scouring and Deposition	<5% of bottom affected by scour or deposition.	6	5-30% affected. Scour at constrictions and where grades steepen. Some deposition in pools.	12	30-50% affected. Deposits and scour at constrictions, constrictions and bends. Some filling of pools.	18	More than 50% of the bottom in a state of flux or change nearly yearlong.		
	15	Aquatic Vegetation	Abundant growth moss-like, dark green potential. In swift water, too.	1	Common. Algae ferns in low velocity and pool areas. Moss fern, too.	2	Present but spotty, mostly in backwater. Seasonal algal growth makes rocks slick.	3	Present but spotty, mostly in backwater. Seasonal algal growth makes rocks slick.		
	Excellent Total =				Good Total =				Fair Total =		Poor Total =

The following sections of the report discuss the data collected and process used to complete the Phase I rapid geomorphic assessment.

4.2 Channel Stability Variables

Channel stability, or channel state, is the primary focus of the Phase I rapid assessment to determine general quality of the streams to be inundated by the Lower Bois d'Arc Creek Reservoir for use in the 404 Permit Application. The adverse consequences of stream channel instability are increased sediment supply, land loss, habitat deterioration, changes in the long- and short-term channel evolution, and loss of both physical and biological functions of the stream.

Channel stability was determined from field inspections, measurements of stream channel characteristics, and by comparing existing stream conditions to historic maps and aerial photography. Specific categories and variables included in the evaluations are riparian vegetation, sediment deposition patterns, erosion potential, debris occurrence, and altered states due to manmade disturbances.

Compare Historic Maps and Aerial Photography

A map of the Bois d'Arc Creek system dating from circa 1915 was used along with aerial photography from 1950, 1976, and 2007 to evaluate changes in stream patterns, land use practices, and riparian vegetation. The impacts of these changes on the channel pattern and profile were evaluated and documented.

Riparian Vegetation

Riparian vegetation performs several functions in a stream system including bank stabilization, water quality protection, fish and wildlife habitat, and thermal cover for the stream. For the purpose of the rapid geomorphic assessment, the bank stabilization potential was the key reason for collecting the riparian buffer information; however, the additional information collected may be helpful in supplementing data collected for the environmental report, habitat evaluation, and 404 permit application.

Bank stabilization and water quality are improved with good riparian buffers because the roots of trees and shrubs help hold stream banks in place, preventing erosion. Riparian vegetation also traps sediment and pollutants.

The field data collected includes information on the general type and condition of the riparian vegetation including an estimate of the percentage of the channel that has trees, shrubs, and grasses. Rooting depth, root density and the percentage of the bank protected by vegetation are specific measurements that were taken at each data point. This information is used in both the preliminary bank stability and channel stability classifications.

Bank Stability Rating Process

The Bank Stability parameters include several related to the riparian vegetation and the bank angle. Although we did not use the Bank Erosion Hazard Index (BEHI) scoring system, we did reference the system for help in determining the key parameters to be evaluated in relation to the channel erosion potential (Rosgen, 2006). Riparian vegetation, as discussed above, plays a key role in bank stabilization. Banks with dense, deep rooting zones and in-channel vegetative cover in alluvium generally have stable banks while shallow, sparse roots and no in-stream vegetation result in unstable banks that are subject to mass wasting. Erosion potential related to bank angle, or slope steepness, generally ranges from very low for flat slopes to extreme for steep slopes; however, there is a correction factor associated with bank angle to take into consideration the bank material (i.e. bedrock can be very stable at steep angles while sand and clay are not).

Channel Stability Rating Process

The channel stability rating system utilized for this assessment is based on the measurement of up to 15 variables that are specific to the channel bottom, the lower banks within the channel, and the upper banks of the channel. Although we did not use the Rosgen-Pfankuch rating system, we did reference the system for help in determining the key parameters to be evaluated in relation to the channel stability (Rosgen, 2006). The channel stability rating process evaluates the upper banks, lower banks, and streambed for evidence of excessive erosion or deposition, which are indicative of disequilibrium and can be used to identify potential aquatic habitat within a stream. The system quantitatively evaluates the potential for mass wasting of the channel banks, the detachability of bank and bed materials, channel capacity, and evidence of either excessive erosion or deposition. The process provides a means for estimating general channel stability.

The upper bank variables considered are the general slope of the upper bank, evidence of mass wasting, size and volume of debris jams, and vegetative bank protection. Bank slope and mass wasting are clear indicators of bank stability and potential sediment load input into the stream.

Steep slopes and mass wasting are evidence of lateral migration. Debris jams, as opposed to in-stream cover, provide evidence of the mass wasting process and loss of large amounts of riparian vegetation due to lateral migration of the streambank. An over abundance of woody debris can profoundly affect stream channel stability by affecting sediment transport (can become a knick point forcing head cutting or down cutting), local bank stability, and channel form.

The lower bank variables consider the ability of the channel to carry bankfull discharges, material makeup of the bank, flow obstructions, and evidence of cutting and deposition. Channel capacity is a measure of entrenchment and the ability of the stream pattern and profile to carry the stream forming flows. While bank materials (sand, clay, rock, etc.) identify the potential of the banks to withstand near bank stress without failing, the flow obstructions are a means for identifying objects such as debris and large rocks that could cause erosive cross currents and bank cutting. Bank cutting is perhaps one of the most critical variables identified in the lower bank region of a stream because undercutting results in sloughs and mass wasting that can introduce large amounts of sediment into the stream while increasing the width and lateral migration of the channel. Depositional patterns are easily observed channel features that can be used to interpret the overall condition of the stream. These patterns can provide insight into the sediment supply, channel adjustments caused by lateral migration or widening, and changes in flow regime.

The variables evaluated for the channel bottom included rock angularity, brightness of the channel material, particle consolidation and size distribution, and aquatic vegetation. Angularity of the bed material provides a means for estimating the stream power required to carry bed load. Rounded and smooth bed material will require lower shear stress and stream power to move the sediment than if it has sharp edges and rough surfaces. Brightness of the bed material is a simple means for determining if small materials such as silt and clay are being deposited. Deposition of this material can indicate a lack of stream power and excess sediment load in the system; moreover, the deposition of this material can lead to the filling of pools and riffles resulting in the lack of in-stream habitat. Scour and deposition are clear indicators of whether or not the stream has either too much, or too little sediment to maintain dynamic equilibrium. Aquatic vegetation, an important component for biological activity, is a measure of stability within the channel bottom because it indicates if the material is being mined or buried (i.e. if the vegetation is permanent or transitory in nature).

Channel Depositional Features

The description of depositional features utilized for this study is from Mollard (1973) and Galay et. al. (1973) as modified by Rosgen (2006). Depositional features are often an indicator of channel aggradation and that the channel is not in equilibrium; however, as shown in the Channel Evolution sequence in Section 3.0 – Incised Channel Evolution Model, deposition is also a major component of a channelized system recovering to a state of dynamic equilibrium.

Field observations and interpretations of the depositional patterns were used in determining the overall state of the channel. Depositional patterns in altered or degraded channel reaches aided in determining if the stream channel was beginning to recover or not.

In-stream Habitat Potential

As dying or uprooted trees fall into the stream, their trunks, root wads, and branches slow the flow of water. Large snags create fish habitat by forming pools and riffles in the stream. However, excess debris can result in the creation of temporary dams that can change both the sediment transport and hydraulic geometry of localized reaches.

Riffles are areas in a stream where shallow water flows swiftly over substrate to produce surface agitation. Channel instability, particularly mass wasting of the channel banks and the continued widening of the channel, results in an excessive sediment load that can bury riffles and fill pools (deep, flat sections of stream) destroying potential habitat.

Cool stream temperatures maintained by riparian vegetation are essential to the health of aquatic species. A dense tree canopy over a creek assists in protecting against elevated water temperatures. The denser the canopy the more protection the creek receives.

Photographs

In addition to the data discussed above, photographs were taken at each data collection point to record visual observations. Photographs looking upstream and downstream were taken at each data point and, at some locations, photographs of the right and left banks were also taken. Representative photographs are included on the Classification Sheets in Appendix A.

4.3 Channel Stability Rating

All of the variables discussed in Section 4.2 were assessed for each data point and consolidated into a Rapid Assessment Classification Sheet (Figure 4.5). The data were then used to determine a general stability rating (good, fair, or poor) for that portion of the creek. These classification sheets were then used in conjunction with field notes, aerial photographs, one-foot LIDAR generated topography and two-foot aerial topography to relate the measured and observed sections of the study reaches to other sections of the creeks to determine their stability rating.

The stability rating system was developed by Freese and Nichols to provide an objective means for assigning values to the six major parameters identified in Figure 4.5. In order to provide a quantitative measurement of the six evaluation factors, the system relies on the physical parameters measured and recorded on the data collection sheet, bank stability form, and channel stability form. Data are first recorded in the field on those forms and select photographs are attached for future reference. Finally, the information on those three forms is used to complete the Rapid Assessment Classification form. The weighting and scoring system was developed to provide an objective means for interpreting the data and classifying the stream reaches.

A rating of "Good" indicates that the channel reach provide stable channel sections and the sediment transport capacity is balanced with sediment supply. The riparian vegetation consists of a variety of species that provide good stream bank coverage (armoring) and a dense root system. A rating of good also means the reach provides good, permanent, in-stream habitat. (Type V of ICEM).

A rating of "Fair" indicates that the channel is not completely stable. Fair reaches provide moderately stable channel sections but are still subject to some bank erosion and sediment transport capacity has not yet balanced with sediment supply. However, inner berms and emergent vegetation are present and the reach is recovering, and both the riparian and in-stream habitat is still somewhat transitional. (Type IV of ICEM).

"Poor" rated reaches are still in a state of disequilibrium. These reaches are continuing to erode and are subject to mass wasting. As a result of the disequilibrium these sections do not contain stable channel sections, riparian vegetation, or in-stream habitat. (Type II and III of ICEM).

The following section summarizes the characteristics and stability ratings of each of the five study reaches.

5.0 Results

The present day Bois d’Arc Creek system is characterized by the previous channel straightening, changing vegetated buffer, current incision, and the incision induced widening of the main stem of Bois d’Arc Creek and its’ major tributaries. The following sections present the results of the rapid assessment and classification of Bois d’Arc Creek and the four studied tributaries.

5.1 Bois d’Arc Creek

There are approximately 89,300 feet (16.9 miles) of Bois d’Arc Creek within the proposed inundation pool of Lower Bois d’Arc Reservoir. Due to the extent of the creek and large variability of channel morphology, Bois d’Arc Creek was separated and analyzed as five separate reaches. Table 5.1 summaries the stationing for each reach and Figure 5.1 shows the location of each reach along the creek.

Table 5.1
Summary of Lower Bois d’Arc Creek Reach Information

Reach	Station
1	0+00 – 70+00
2	70+00 – 190+00
3	190+00 – 240+00
4	240+00 – 486+00
5	486+00 – 893+00

Approximately sixty-two percent (62%) of the main stem of Bois d’Arc Creek within the proposed reservoir was channelized. Reaches 1, 3, and 5 represent the channelized reaches. Figures 5.4, 5.9, and 5.15 provide examples of the typical channelization that took place along the creek. By comparing the historical map circa 1915 to the aerial imagery of 1950, we concluded that most of the channelization to the creek occurred between 1915 and 1950. Since 1950, several road crossings have been constructed where approximately 3,000 additional feet has been straightened. Due to the manmade alterations to the creek, the flowline has downcut causing a headcut effect propagating up the creek. Evidence of the down cutting can be seen in the longitudinal profiles for Bois d’Arc Creek in Figures 5.2 and 5.3.

The dominant channel material for Bois d’Arc Creek is clay with accumulations of shale, gravel, sand, and silt in the depositional features throughout the reaches. Each segmented reach of

Bois d'Arc Creek is very diverse in its physical characteristics, vegetation, and overall stability. The following sections describe each reach in detail. The Rapid Assessment Classification sheets for each reach are found in Appendix A.

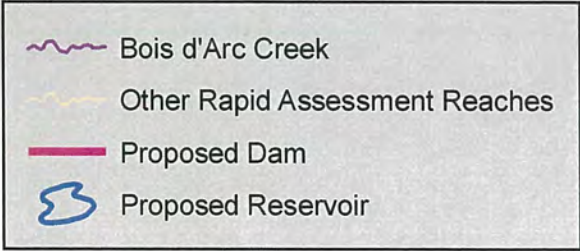
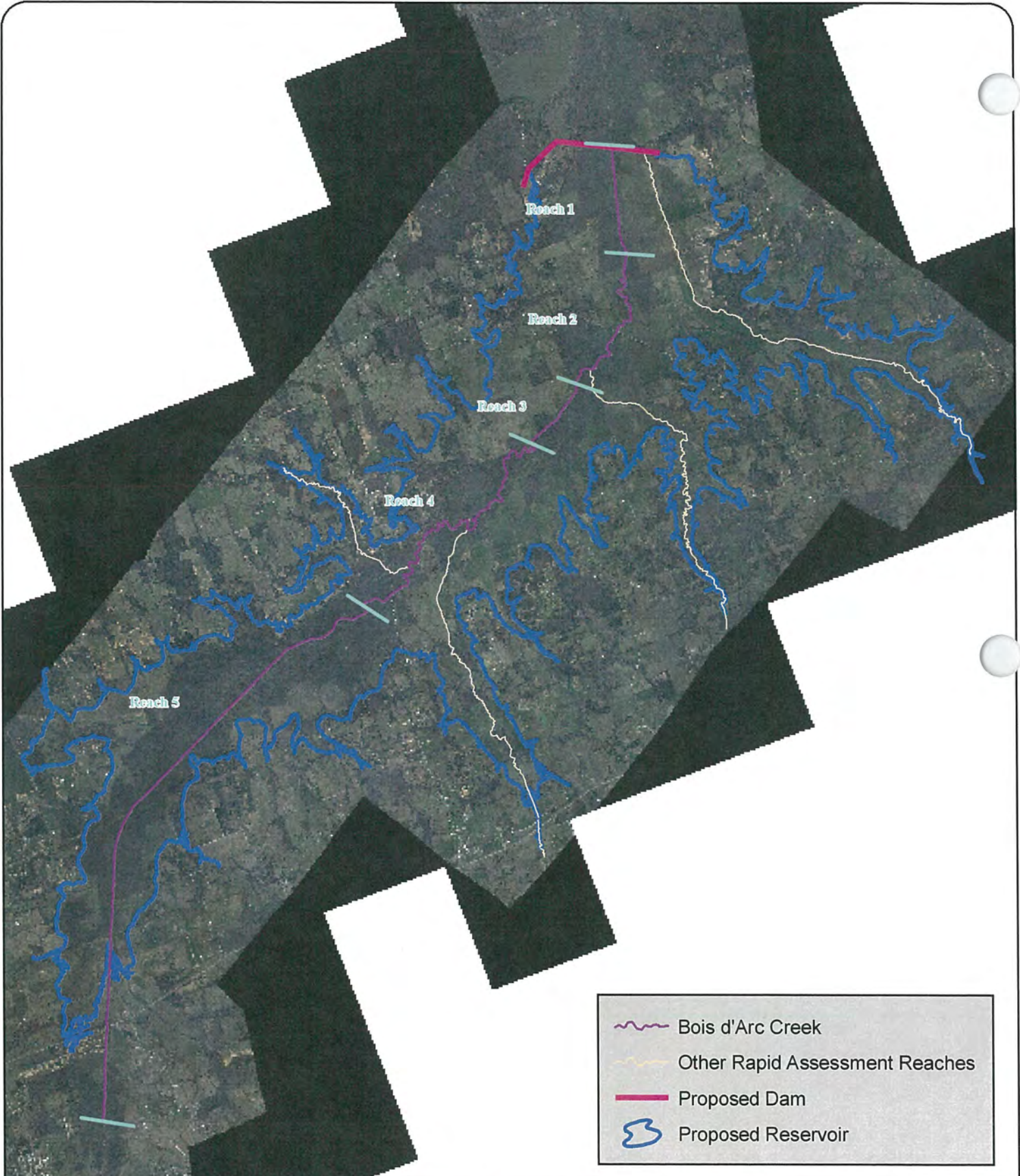

FN PROJECT NO.	NTD06128
DATE	July 2008
DATUM & COORDINATE SYSTEM	NAD83 State Plane
FILE	Fig5o1_AilBDCreek.mxd
PREPARED BY	JM

Freese and Nichols
 10814 Jollyville Road
 Building 4, Suite 100
 Austin, TX 78759
 Phone: (512) 617-3100
 Fax: (512) 617-3101

North Texas Municipal Water District
Proposed Lower Bois d'Arc Reservoir Project
Bois d'Arc Creek

0 0.5 1 2
 Miles

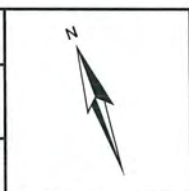

FIGURE
 5.1

DATE: FEB 01, 2008 4:41:37 A.M. USER: GAL TITLE: BOIS D'ARC CREEK

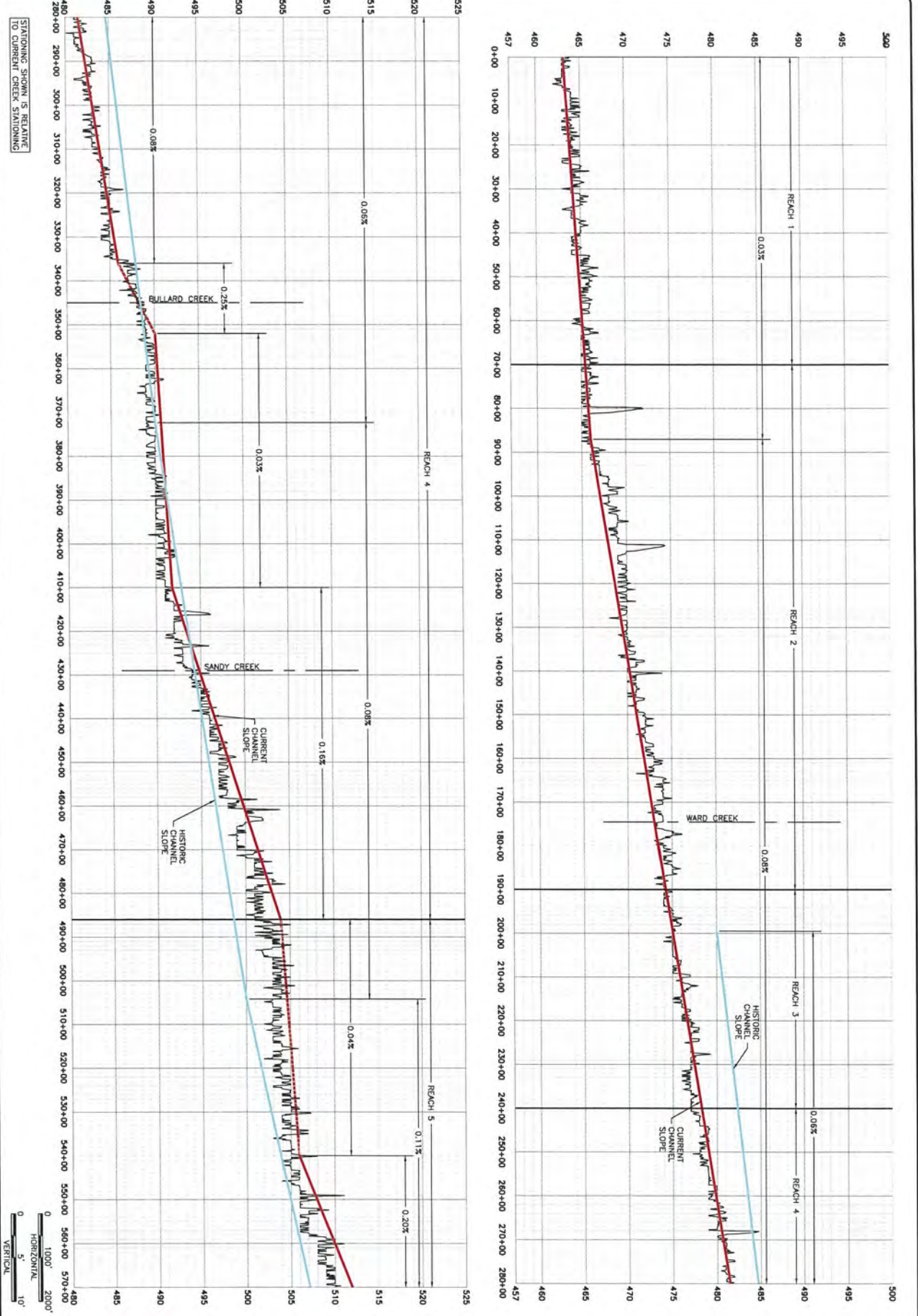

FIGURE 5.2



NORTH TEXAS MUNICIPAL WCID
 LOWER BOIS D'ARC CREEK PROPOSED RESERVOIR PROJECT
 FLUVIAL GEOMORPHOLOGY

BOIS D'ARC CREEK

P&N JOB NO.	NTD06128
DATE	1/25/08
SCALE	AS SHOWN
DESIGNED	JWS
DRAFTED	GAL/CJE

FILE: BoisD'ArcHistoricOverlay.dwg

DATE: Sep 10, 2008 11:23am USER: cje FILE: N:\WorkArea\Users\cjc\arc\over.dwg

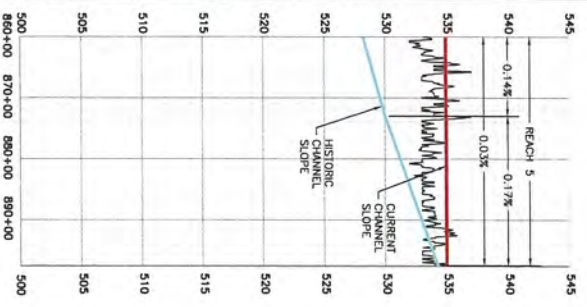

STATIONING SHOWN IS RELATIVE TO CURRENT CREEK STATIONING

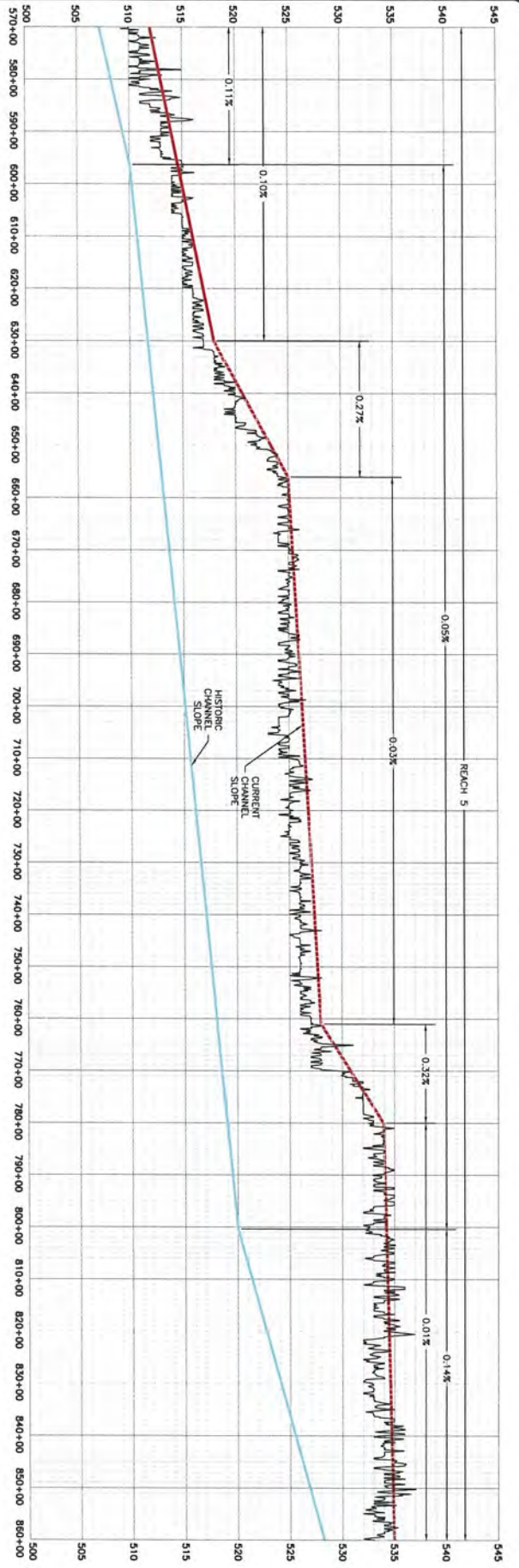
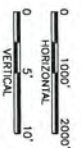

Freese and Nichols
 10214 Jollyville Road Building V Suite 100
 Austin, Texas 78750
 Phone - (512) 617-3100
 Fax - (512) 617-3101

NORTH TEXAS MUNICIPAL WCD
LOWER BOIS D'ARC CREEK PROPOSED RESERVOIR PROJECT
 FLUVIAL GEOMORPHOLOGY
BOIS D'ARC CREEK

F&N JOB NO.	NTD06128
DATE	1/25/08
SCALE	AS SHOWN
DESIGNED	JWS
DRAFTED	GAL/CJE

FILE: BoisDARCHistoricOverlay.dwg

Reach 1

Reach 1 of Bois d'Arc Creek (Figure 5.1) is the most downstream reach of the study area, accounting for approximately 8% of the total stream length. Comparing the alignment of this reach today to the circa 1915 map, shows that the entire 7,000 feet of the reach has been straightened. An example of the channelization of this reach is shown in Figure 5.4.



Figure 5.4 - Comparison of Historic to Existing Channel Alignment for Reach 1 of Bois d'Arc Creek

As shown in Figure 5.2, the channelization of Reach 1 has propagated upstream to Station 87+00 with an average channel slope of 0.03%. Figure 5.5 provides a typical view of Reach 1 of Bois d'Arc Creek. This reach has an average top width of 140 feet, average depth of 15 feet, with almost vertical side slopes. The riparian vegetation along the banks is moderate, with a mix of grasses along the mid slope and small trees and grasses on the upper slope. The lower banks have little to no vegetation providing little bank protection. Due to the absence of woody shrub species along the slopes, there is a limited root zone causing undercut stream banks. Depositional side bar features are common due to high sediment load from the steep banks and the shallow channel slope. Streambank erosion rates in some areas appear to be high due to undercut banks and mass wasting. There is little habitat potential in this reach, with very little shade over the creek and incised channel banks.

In terms of the rapid assessment classification of Reach 1 of Bois d'Arc Creek, this reach seems to be in Type III of the channel evolution process. The stability of this reach is evenly split, with approximately 51% of the reach given a "fair" rating and the other 49% a "poor" rating. The

rapid geomorphic classification for this reach is presented as Figure 5.20 at the end of this section.



Figure 5.5 - Reach 1 of Bois d'Arc Creek.

Reach 2

Reach 2 of Bois d'Arc Creek (Figure 5.1) stretches from Station 70+00 to 190+00, covering approximately 13% of the total stream length. Most of this reach has not been straightened and matches quite closely to the 1915 meandering alignment. However, 1,500 feet of the reach was straightened between 1950 and 1976 to accommodate F.M. 1396. There are two locations along the reach where a chute cutoff has formed (near Sta. 127+00 and 178+00), making the chutes the main stem of the creek and abandoning the original alignment over time. Figure 5.6 provides an example of one of the chute cutoffs.

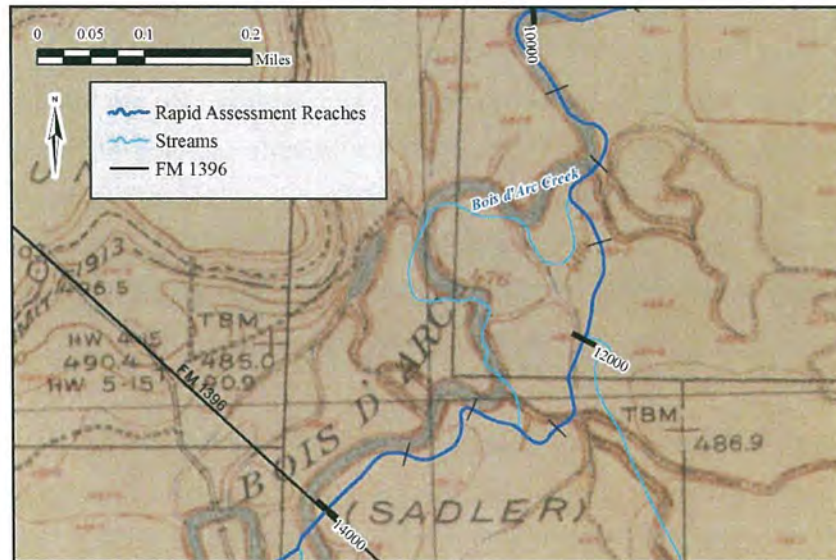

Figure 5.6 - Chute Cutoff in Reach 2 of Bois d'Arc Creek

As shown in Figure 5.2, Reach 2 has an average channel slope of 0.08%, but channelization of the downstream reach is causing a headcut into this reach. Figures 5.7 and 5.8 provide typical views of Reach 2 of Bois d’Arc Creek.



Figure 5.7 - Reach 2 of Bois d’Arc Creek during winter



Figure 5.8 - Reach 2 of Bois d’Arc Creek during summer

The physical characteristics of this reach are very similar to that of Reach 1, except that this reach is very sinuous. Reach 2 has an average top width of 140 feet, average depth of 15 feet, with almost vertical side slopes. The riparian vegetation along the banks is scarce, with a mix of grasses along the mid slope and small trees and grasses on the upper slope. The lower banks

have little to no vegetation providing little bank protection. Due to the absence of woody shrub species along the slopes, there is a limited root zone causing undercut stream banks. Depositional side bars, point bars, and mid-channel bars are common due to high sediment load from the steep banks and the shallow channel slope. Streambank erosion rates in some areas appear to be high due to undercut banks and mass wasting. There is little habitat potential for this reach, with very little shade over the creek and incised channel banks.

In terms of the rapid assessment classification of Reach 2 of Bois d'Arc Creek, the upper reaches of this creek seem to be in Type III of the channel evolution process. Downstream of F.M. 1396, the creek seems to be in transition between Types III and IV, with an inner berm forming inside the channel (Figure 5.8b). The stability of this reach is predominantly poor, with approximately 45% of the reach given a "fair" rating and the other 55% a "poor" rating. The rapid geomorphic classification for this reach is presented as Figure 5.20 at the end of this section.



Figure 5.8b - Reach 2 of Bois d'Arc Creek showing the formation of an inner berm.

Reach 3

Reach 3 of Bois d'Arc Creek (Figure 5.1) stretches from Station 190+00 to 240+00, covering approximately 6% of the total stream length. Comparing the alignment of this reach today to the circa 1915 map, shows that the entire 5,000 feet of the reach has been straightened. An example of the channelization of this reach is shown as Figure 5.9.

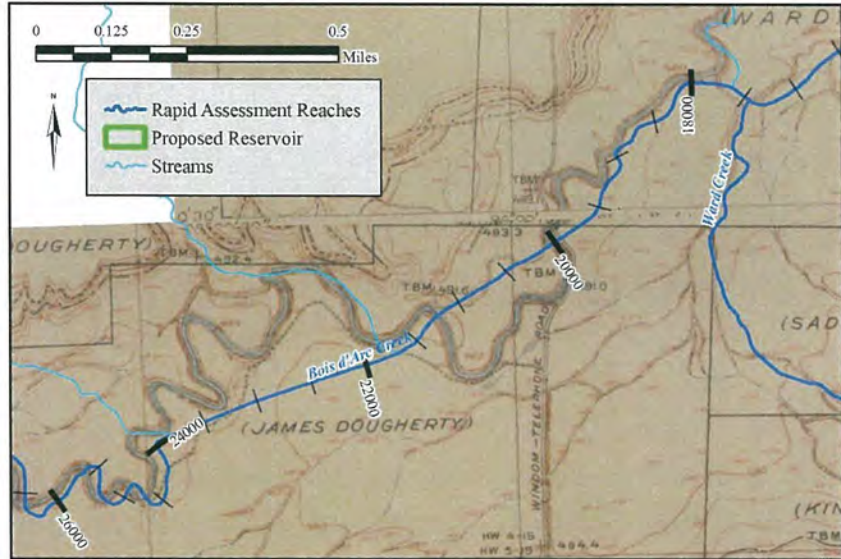

Figure 5.9 - Comparison of Historic to Existing Channel Alignment for Reach 3 of Bois d'Arc Creek

As shown in Figure 5.2, Reach 3 has an average channel slope of 0.08%. Figures 5.10 and 5.11 provide typical views of Reach 3 of Bois d'Arc Creek.



Figure 5.10 - Reach 3 of Bois d'Arc Creek during summer.



Figure 5.11 - Reach 3 of Bois d'Arc Creek during winter.

The physical characteristics of this reach are very similar to that of Reach 1. This reach has an average top width of 140 feet, average depth of 15 feet, with almost vertical side slopes. The riparian vegetation along the banks is scarce, with a mix of grasses along the mid slope and large trees and grasses on the upper slope. The lower banks have little to no vegetation providing little bank protection. Due to the absence of woody shrub species along the slopes, there is a limited root zone causing undercut stream banks. Depositional side bar features are common due to high sediment load from the steep banks and the shallow channel slope. Streambank erosion rates appear to be very high due to undercut banks and mass wasting (Figure 5.11), especially from Station 203+00 to 240+00. There is little habitat potential for this reach, with very little shade over the creek and incised channel banks.

In terms of the rapid assessment classification of Reach 3 of Bois d'Arc Creek, this reach seems to be in transition between Types III and IV, with an inner berm forming inside the channel. The stability of this reach is very poor, with 99% of the reach given a "poor" rating and 1% of the reach given a "fair" rating. The rapid geomorphic classification for this reach is presented as Figure 5.21 at the end of this section.

Reach 4

Reach 4 of Bois d'Arc Creek (Figure 5.1) stretches from Station 240+00 to 486+00, covering approximately 27% of the total stream length. Most of this reach has not been straightened and resembles quite closely the 1915 meandering alignment. However, 1,500 feet of the reach was straightened between 1915 and 1950 to accommodate County Road 2945 (Figure 5.12).



Figure 5.12 - Comparison of Historic to Existing Channel Alignment for Reach 4 of Bois d'Arc Creek

There is one location along the reach where a chute cutoff has formed (Sta. 300+00), making the chute the main stem of the creek and abandoning the original alignment over time. Figures 5.13 and 5.14 provide typical views of Reach 4 of Bois d'Arc Creek.



Figure 5.13 - Reach 4 of Bois d'Arc Creek during winter



Figure 5.14 - Reach 4 of Bois d'Arc Creek after summer rain event

The physical characteristics of Reach 4 are very different from that of the lower reaches. For the portion of the reach downstream of the confluence with Bullard Creek (approximately Station 240+00 to 345+00), the average top width is 110 feet, average depth is 12 feet, with an average channel slope of 0.08%. For the portion of the reach between the confluences of Bullard Creek and Sandy Creek with Bois d'Arc Creek (approximately Sta. 345+00 to 429+00), the average top width is 110 feet, average depth of 8 feet, with an average channel slope of 0.03%. For the portion of the reach upstream of Sandy Creek (approximately Station 429+00 to 485+00), the average top width is 50 feet, average depth is 4 feet, with an average channel slope of 0.16%. All of the stream segments have almost vertical side slopes. The channel dimensions for each stream segment coincide with the introduction of tributaries along Bois d'Arc Creek.

The riparian vegetation and stream cover for this reach is very different from that of the lower reaches. The vegetation along the banks is minimal, with a mix of grasses and dense tree roots covering approximately 20% of the slope. Due to the absence of woody shrub species along the slopes, there is a limited root zone causing undercut stream banks. However, there is new growth along the slopes providing evidence that the banks are trying to recover. Along the upper banks of the reach, there are good stands of trees providing good stream cover and rooting depth. Depositional side bars, point bars, and mid-channel bars are common due to high sediment load from the eroding banks. Streambank erosion rates appear to be high due to

undercut banks. There is moderate habitat potential for this reach, with ample stream cover and deep pools.

In terms of the rapid assessment classification of Reach 4 of Bois d'Arc Creek, this reach seems to be in Type III of the channel evolution process. The stability of this reach is predominantly fair, with approximately 70% of the reach given a "fair" rating and the other 30% given a "poor" rating. The rapid geomorphic classification for this reach is presented as Figure 5.21 at the end of this section.

Reach 5

Reach 5 of Bois d'Arc Creek (Figure 5.1) is the most upstream reach of the study area, covering approximately 46% of the total stream length. The entire 40,700 feet of the reach has been straightened. An example of the channelization of this reach is shown as Figure 5.15.

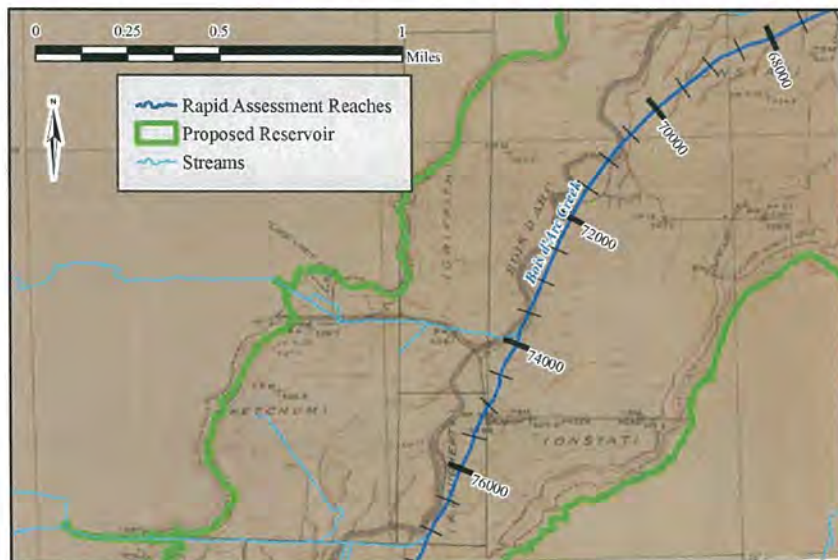

Figure 5.15 - Comparison of Historic to Existing Channel Alignment for Reach 5 of Bois d'Arc Creek

The channel dimensions vary greatly throughout the reach. Approximately 25% of the reach (Sta. 635+00 to 690+00 and 780+00 to 830+00) has limited channel capacity, with flood flows overtopping the banks during minor flood events, creating a wide expansive floodplain. Figure 5.16 shows an example of a stream segment in this area classified as "poor." Figure 5.17 shows an example of a stream segment in this area classified as "fair."

As depicted in Figure 5.16, there is a very established root zone lining the banks of this reach creating habitat and stabilization for the banks. However, these roots cover approximately 20%

of the banks, with the remaining percentage left as barren slopes. In addition, the side slopes are vertical, causing undercut banks. Channel slopes for this segment of reach average 0.01%.



Figure 5.16 - A “poor” rated reach on Reach 5 of Bois d’Arc Creek.



Figure 5.17 - A “fair” rated reach on Reach 5 of Bois d’Arc Creek.

Conversely, Figure 5.17 represents a stream segment along Reach 5 classified as “fair.” Even though the stream has little capacity, the banks are stable with a variety of woody species. Channel slopes for this segment of reach average 0.03%.

Outside of this low lying area, the channel dimensions vary from a top width of 50 feet to 70 feet and a channel depth of three feet to eight feet as you move downstream. Channel slopes for this segment of reach average 0.10%. Figure 5.18 shows an example of a stream segment in this area classified as “poor.” Figure 5.19 shows an example of a stream segment in this area classified as “fair.”



Figure 5.18 - A “poor” rated reach on Reach 5 of Bois d’Arc Creek.



Figure 5.19 - A “fair” rated reach on Reach 5 of Bois d’Arc Creek.

As depicted in Figure 5.18, there is potential for stream cover during the spring and summer months; however, the side slopes are vertical and there is little to no vegetation along the slopes. Conversely, Figure 5.19 has adequate stream cover, laid back side slopes and 70-80% bank cover throughout the section.

In terms of the rapid assessment classification of Reach 5 of Bois d'Arc Creek, this reach is predominantly in poor stability conditions, with approximately 37% of the reach given a "fair" rating and the other 63% given a "poor" rating. The rapid geomorphic classification for this reach is presented in Figures 5.22 and 5.23 at the end of this section.

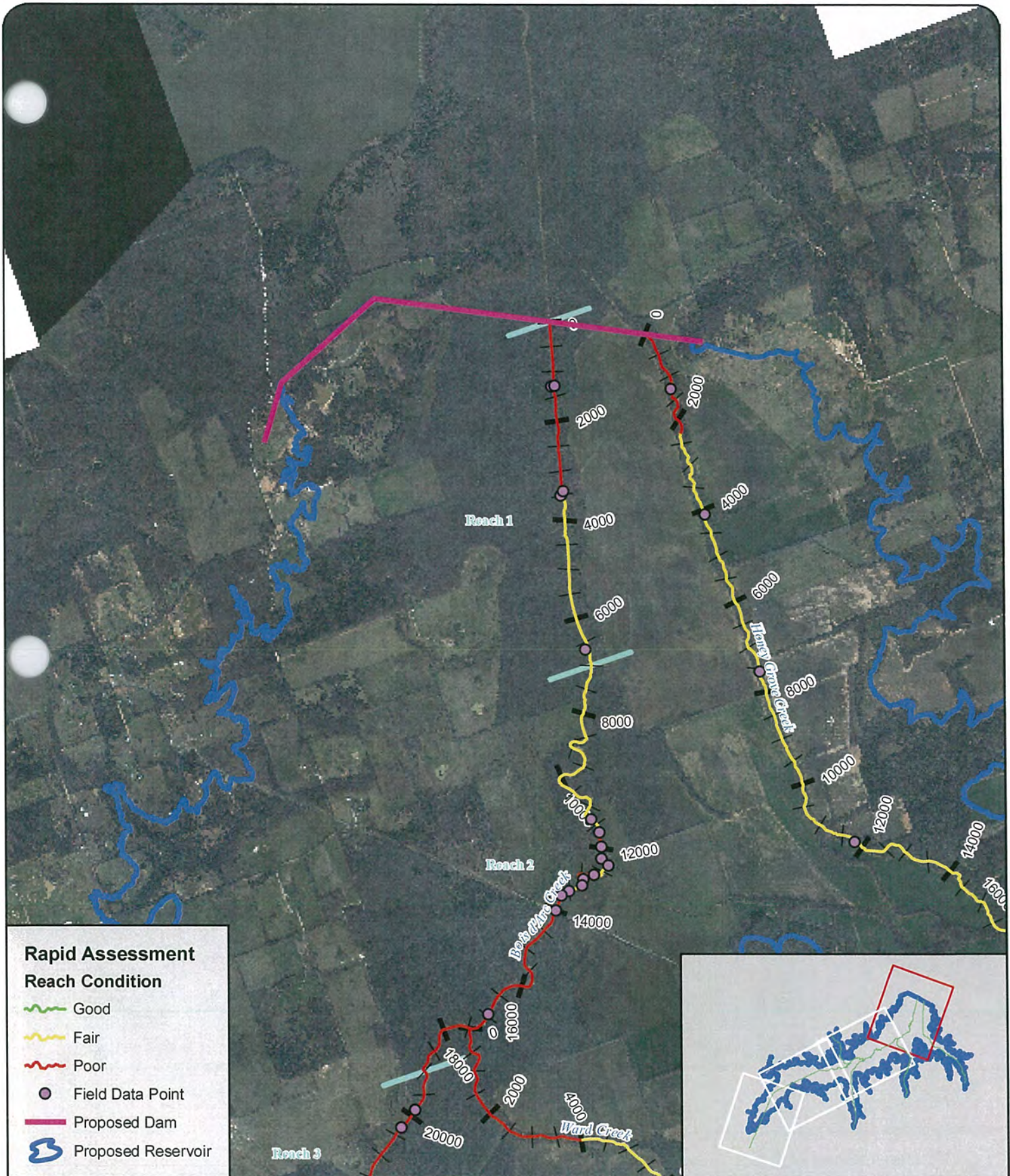

Rapid Assessment Reach Condition

- Good
- Fair
- Poor
- Field Data Point
- Proposed Dam
- Proposed Reservoir



PROJECT NO.	NTD06128
DATE	September 2008
DATUM & COORDINATE SYSTEM	NAD83 State Plane
FILE	Fig5o20_BDCreek1.mxd
PREPARED BY	JM

Freese and Nichols
 10814 Jollyville Road
 Building 4, Suite 100
 Austin, TX 78759
 Phone: (512) 617-3100
 Fax: (512) 617-3101

North Texas Municipal Water District
Proposed Lower Bois d'Arc Reservoir Project
Bois d'Arc Creek

0 0.25 0.5 1 Miles

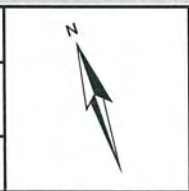
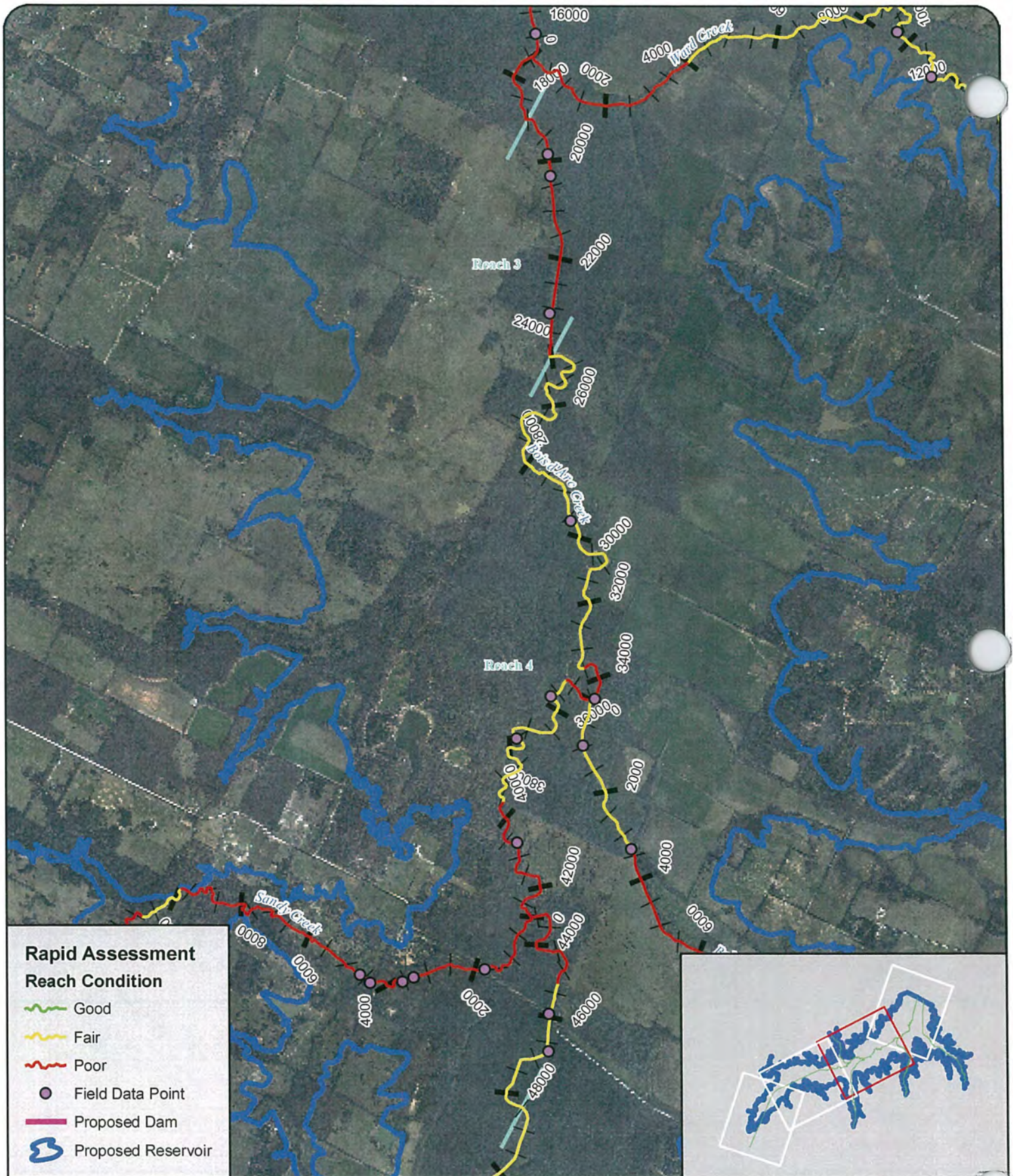

FIGURE
5.20



Rapid Assessment Reach Condition

- Good
- Fair
- Poor
- Field Data Point
- Proposed Dam
- Proposed Reservoir

FN PROJECT NO.	NTD06128
DATE	September 2008
DATUM & COORDINATE SYSTEM	NAD83 State Plane
FILE	Fig5021_BDCreek2.mxd
PREPARED BY	JM

Freese and Nichols
 10814 Jollyville Road
 Building 4, Suite 100
 Austin, TX 78759
 Phone: (512) 617-3100
 Fax: (512) 617-3101

North Texas Municipal Water District
Proposed Lower Bois d'Arc Reservoir Project
Bois d'Arc Creek

0 0.25 0.5 1 Miles



FIGURE
5.21

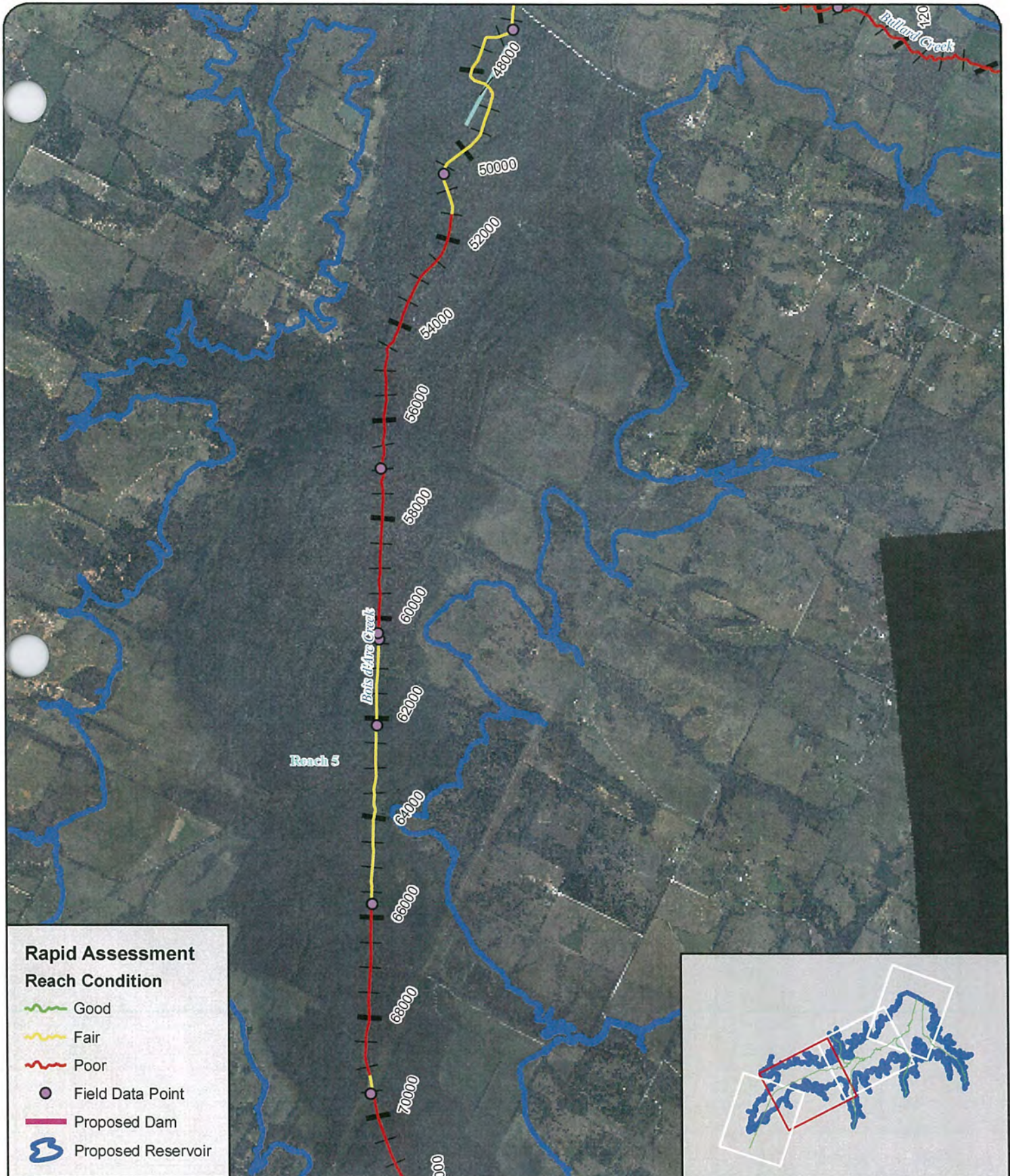

Rapid Assessment Reach Condition

- Good
- Fair
- Poor
- Field Data Point
- Proposed Dam
- ⊕ Proposed Reservoir

PROJECT NO.	NTD06128
	September 2008
DATUM & COORDINATE SYSTEM	NAD83 State Plane
FILE	Fig5o22_BDCreek3.mxd
PREPARED BY	JM

Freese and Nichols
 10814 Jollyville Road
 Building 4, Suite 100
 Austin, TX 78759
 Phone: (512) 617-3100
 Fax: (512) 617-3101

North Texas Municipal Water District
Proposed Lower Bois d'Arc Reservoir Project
Bois d'Arc Creek

0 0.25 0.5 1 Miles

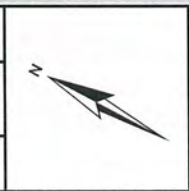
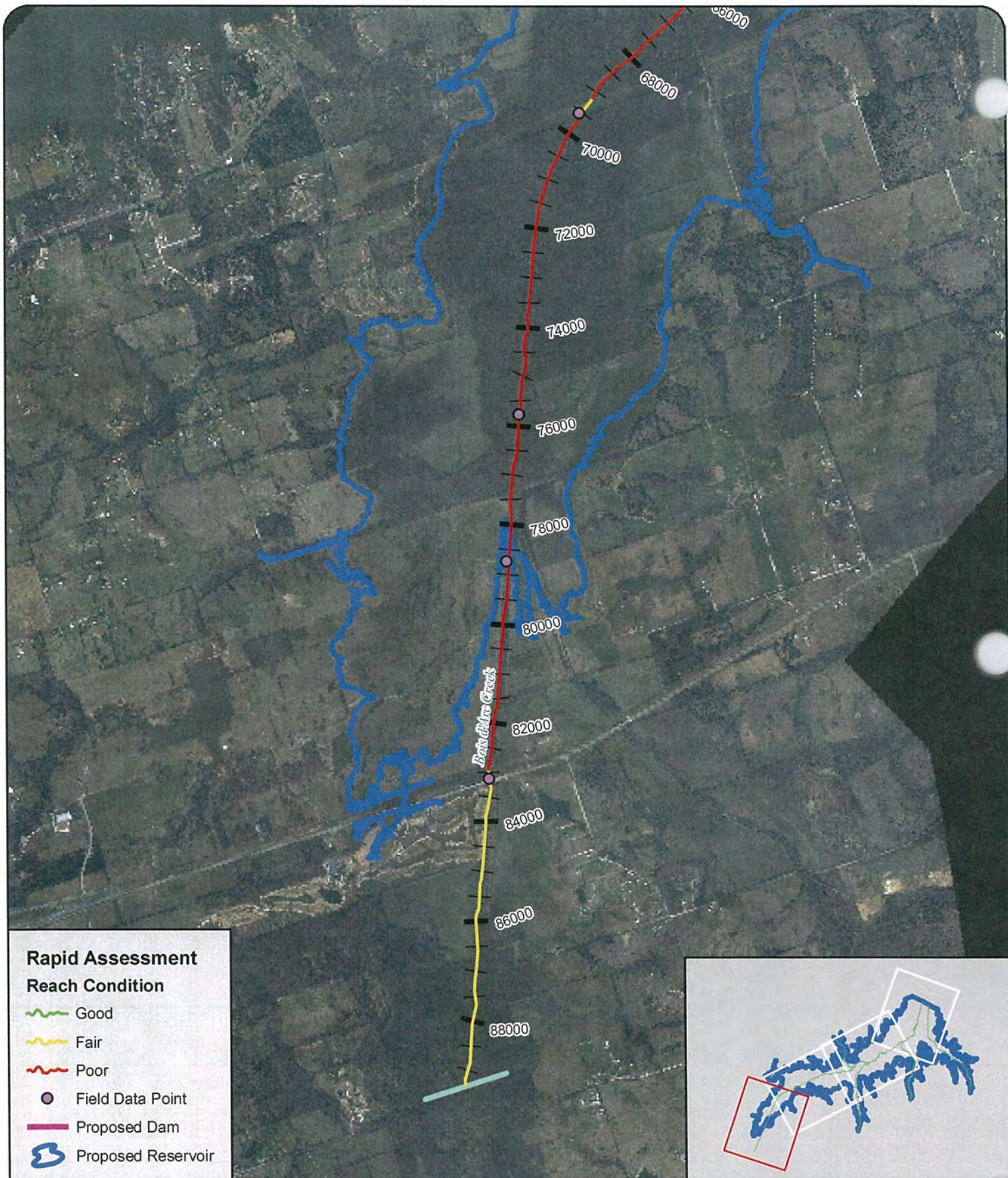

FIGURE
5.22



Rapid Assessment Reach Condition

- Good
- Fair
- Poor
- Field Data Point
- Proposed Dam
- Proposed Reservoir

FN PROJECT NO.	NTD06128
DATE	September 2008
DATUM & COORDINATE SYSTEM	NAD83 State Plane
FILE	Fig5o23_BDCreek4.mxd
PREPARED BY	JM

Freese and Nichols
 10814 Jollyville Road
 Building 4, Suite 100
 Austin, TX 78759
 Phone: (512) 617-3100
 Fax: (512) 617-3101

North Texas Municipal Water District
Proposed Lower Bois d'Arc Reservoir Project
Bois d'Arc Creek

0 0.25 0.5 1 Miles



FIGURE
5.23

5.2 Honey Grove Creek

Honey Grove Creek is a large tributary of Bois d'Arc Creek; however, the confluence of the two streams is located approximately 2,000 feet downstream of the proposed dam. Approximately 35,700 feet (6.8 miles) of Honey Grove Creek is in the proposed inundation pool of Lower Bois d'Arc Creek Reservoir.

Based on the 1915 map of the streams, it appears that approximately 9,500 linear feet of Honey Grove Creek (nearly 30%), within the reservoir, were channelized prior to 1915. Figure 5.24 shows a portion of the reach that was channelized. Our interpretation that this portion of Honey Grove Creek was channelized is evidenced by depiction of the lower end of the present day creek down to the confluence with Bois d'Arc Creek, as a small localized tributary of the main stem with a small ridge between Bois d'Arc Creek and what appears to be an unfinished channel. It appears that the original Honey Grove Creek channel can still be seen in the 1915 map with its confluence with Bois d'Arc Creek at approximate Bois d'Arc Creek Station 74+00 (Figure 5.24).

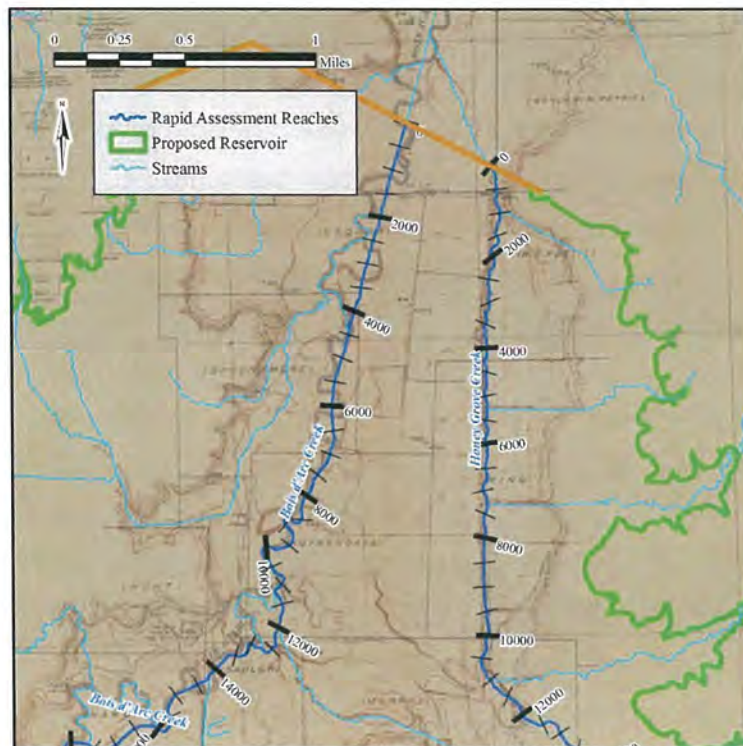

Figure 5.24 - Comparison of Historic to Existing Channel Alignment on Honey Grove Creek.

Portions of the original channel remain discernable through the 2007 aerial photographs although portions appear to have been filled in and converted to farm land. Comparing the 1915 maps to the 1950 aerial shows that the lower 3,000 feet of the present day Honey Grove Creek (downstream of the reservoir) is a manmade channel and the natural channel has been removed for agricultural reasons. We conclude that most of the channelization to the creek occurred between 1915 and 1950. Due to the manmade alterations to the creek, the flowline has downcut causing a headcut to propagate up the creek. Evidence of the down cutting can be seen in the longitudinal profile for Honey Grove Creek in Figure 5.25.

The dominant channel material is sand with minor components of shale gravel in some bars in the lower reach. There is a distinct break in the slopes of the upper half of the stream and the lower half of the stream. With the exception of the lower reach of this creek, there is little variation in terms of physical characteristics, vegetation, and overall stability along Honey Grove Creek.

As shown in the longitudinal profile, the headcutting has propagated upstream to Station 195+00 with an average slope of approximately 0.11%. This lower reach (Sta. 0+00 -195+00) has an average top width of 100 feet, an average depth of 12 feet, and steep side slopes. The riparian vegetation along the banks is moderate, with a mix of grasses along the middle slope and trees and grasses on the upper slope. The lower banks have little to no vegetation in most locations providing little bank protection. Due to the absence of woody shrub species along the slopes, there is a limited root zone causing undercut stream banks. Depositional side bar features are common due to high sediment load from the banks. These depositions are loosely packed and are transitory. There is no evidence that the channel is forming inner berms or a new floodplain at this time. Streambank erosion rates in some areas, particularly the downstream 2,300 feet of the channel, appear to be high due to undercut banks and mass wasting. There is little habitat potential for this reach, with very little shade over the creek and incised channel banks. Figures 5.26 and 5.27 show typical examples of the poor and fair rated stream segments along the lower reach, respectively.

In terms of the rapid assessment classification, the lower reach of Honey Grove Creek appears to be a Type III within the channel evolution process. Although this reach of the channel does not exhibit characteristics of equilibrium, the classification for 87% of the lower reach is a "fair" rating while only the downstream 2,300 feet (13%) is rated "poor" (Figure 5.29).

Station: 280+00 290+00 300+00 310+00 320+00 330+00 340+00 350+00
 User: jmw
 Title: N:\Work\Report\HistoryCoverlay.dwg

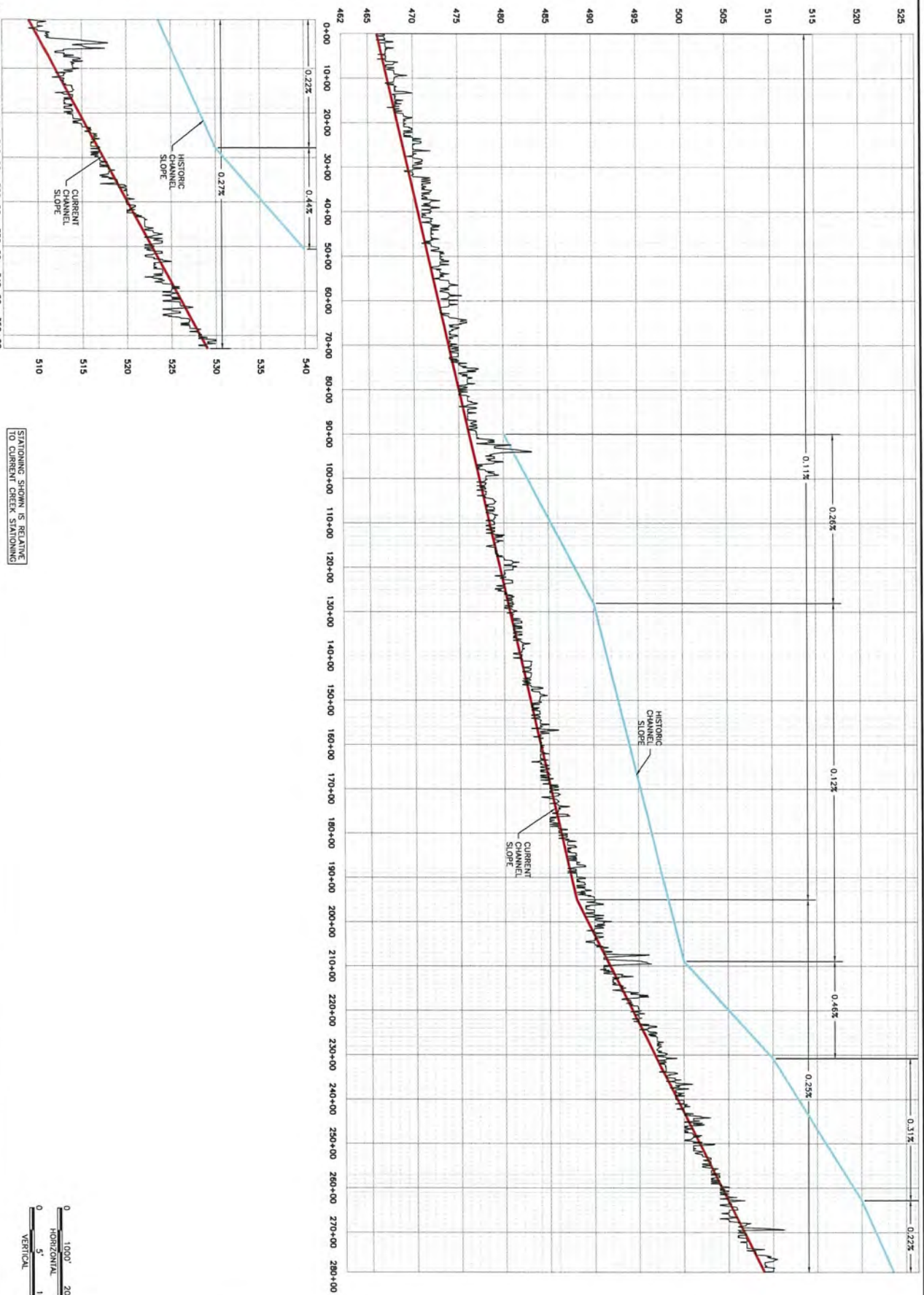

STATIONING SHOWN IS RELATIVE
 TO CURRENT CREEK STATIONING

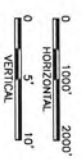

FIGURE 5.25



NORTH TEXAS MUNICIPAL WCID
 LOWER BOIS D'ARC CREEK PROPOSED RESERVOIR PROJECT
 FLUVIAL GEOMORPHOLOGY

HONEY GROVE CREEK

F&N JOB NO.	OFF21021
DATE	SEPT. 2001
SCALE	AS SHOWN
DESIGNED	JWS
DRAFTED	GAL

FILE: HoneyGroveHistoricOverlay.dwg



Figure 5.26: Poor rated section of Honey Grove Creek along lower reach.



Figure 5.27: Fair rated section of Honey Grove Creek along lower reach.

The upper reach of Honey Grove Creek (Sta. 195+00 – 357+00) has an average top width of 132 feet, an average depth of 18 feet, and steep side slopes. The riparian vegetation along the banks is moderate, with a mix of grasses along the mid slope and trees and grasses on the upper slope. The lower banks have varying amounts of grass and small brush throughout this reach. The presence of the vegetation along the slopes is evident by the lack of undercut and sloughing banks. Depositional side bar features are common due to high sediment load from the

banks. There is little habitat potential for most of this reach, with very little shade over the creek and incised channel banks. Figure 5.28 shows a typical view of this fair rated stream segment.



Figure 5.28: Fair rated section of Honey Grove Creek along upper reach.

In terms of the rapid assessment classification, the upper reach of Honey Grove Creek appears to be a Type III, with some segments of Type IV, within the channel evolution process. Although this reach does not exhibit characteristics of equilibrium, the classification for 2,700 feet (15%) of the upper reach is a “good rating”, while the remaining 85% of the reach is a “fair” rating (Figure 5.29).

The classification of the entire reach is predominantly fair, with approximately 86% of the reach given a “fair” rating, 8% a “good” rating, and the remaining 6% a “poor” rating. The rapid geomorphic classification for this reach is presented as Figure 5.29.

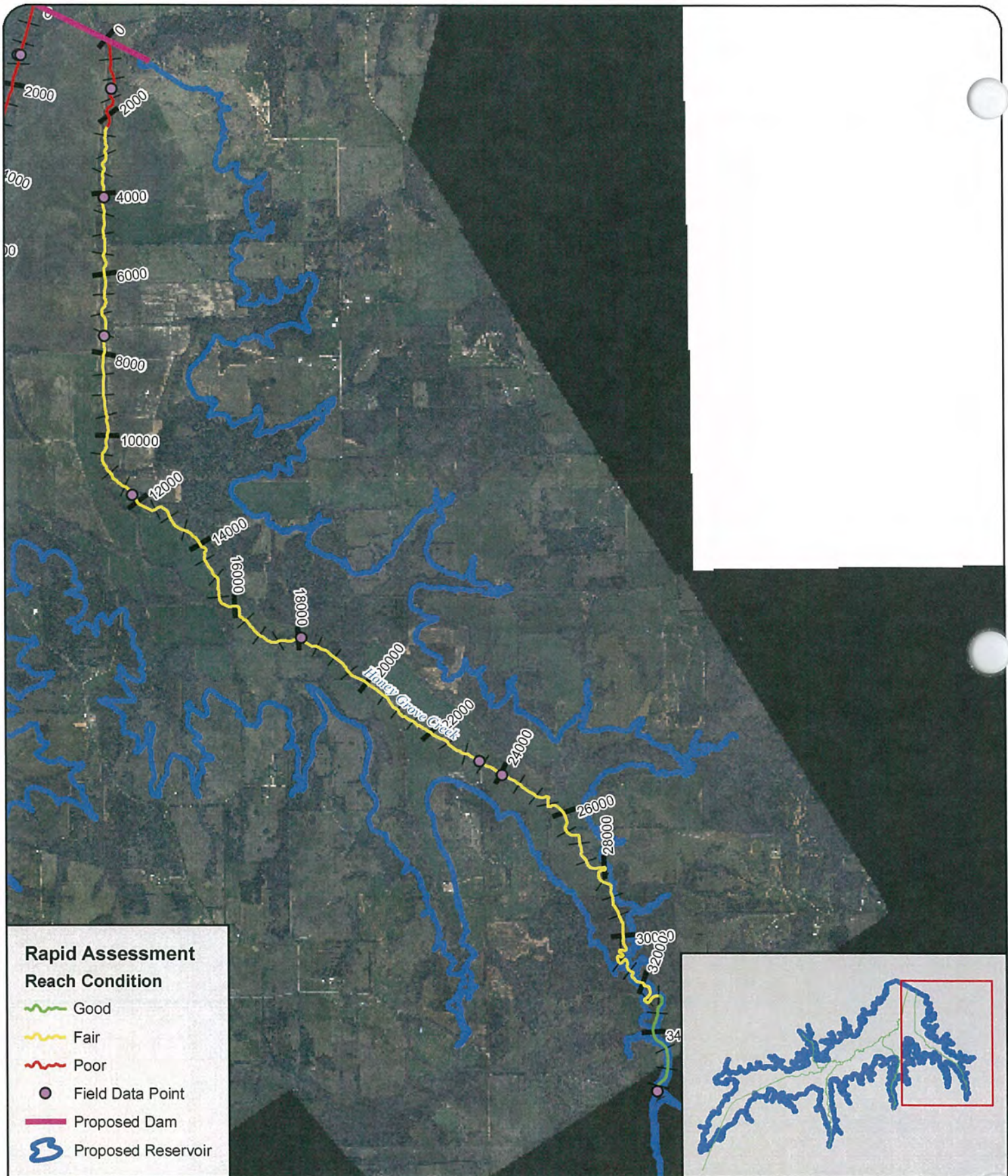

Rapid Assessment Reach Condition

- Good
- Fair
- Poor
- Field Data Point
- Proposed Dam
- Proposed Reservoir

FN PROJECT NO.	NTD06128
DATE	September 2008
DATUM & COORDINATE SYSTEM	NAD83 State Plane
FILE	Fig5o29_HoneyGrove.mxd
PREPARED BY	JM

Freese and Nichols
 10814 Jollyville Road
 Building 4, Suite 100
 Austin, TX 78759
 Phone: (512) 617-3100
 Fax: (512) 617-3101

North Texas Municipal Water District
Proposed Lower Bois d'Arc Reservoir Project
Honey Grove Creek

0 0.25 0.5 1 Miles



FIGURE
5.29

5.3 Ward Creek

Ward Creek is a large tributary of Bois d'Arc Creek with the stream confluence at approximate Station 174+00 on Bois d'Arc Creek. Approximately 27,900 feet (5.4 miles) of Ward Creek are within the proposed inundation pool of Lower Bois d'Arc Reservoir.

Comparing the 1950 aerial photograph to the 1915 map of Ward Creek show that approximately 3,500 to 4,000 feet (approximately 10%) of this stream was channelized between approximate Stations 25+00 and 60+00 (Figure 5.30). Although this section was channelized, it should be noted that the changes in the pattern of this stream were much less aggressive than the alterations to segments of Bois d'Arc Creek and Honey Grove Creek discussed above, as this section of Ward Creek had low sinuosity prior to the channelization.



Figure 5.30 - Comparison of Historic to Existing Channel Alignment on Ward Creek.

As shown in Figure 5.31, Ward Creek has downcut from the confluence with Bois d'Arc Creek upstream to Station 255+00 with an average channel slope of 0.20%. The down cutting and widening of the stream through this reach is evident by comparing the 2007 aerial photographs with the 1950 aeriels. There is a much steeper reach near the end of the proposed inundated portion of Ward Creek with a slope of nearly 0.70%. Depositional side bars are common and, where the stream has downcut, there are signs that a new floodplain is beginning to develop with the channel (Figure 5.32). Streambank erosion rates in some reaches appear to be very high due to mass wasting (Figure 5.33); however, there are long reaches that appear to be recovering with the formation of inner berms and emergent vegetation.

Sheet: Sep 10, 2008 10:23:09 User: JMW File: N:\Work\Report\WardHistoricOverlay.dwg

STATIONING SHOWN IS RELATIVE
 TO CURRENT CREEK STATIONING

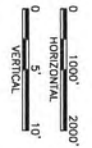
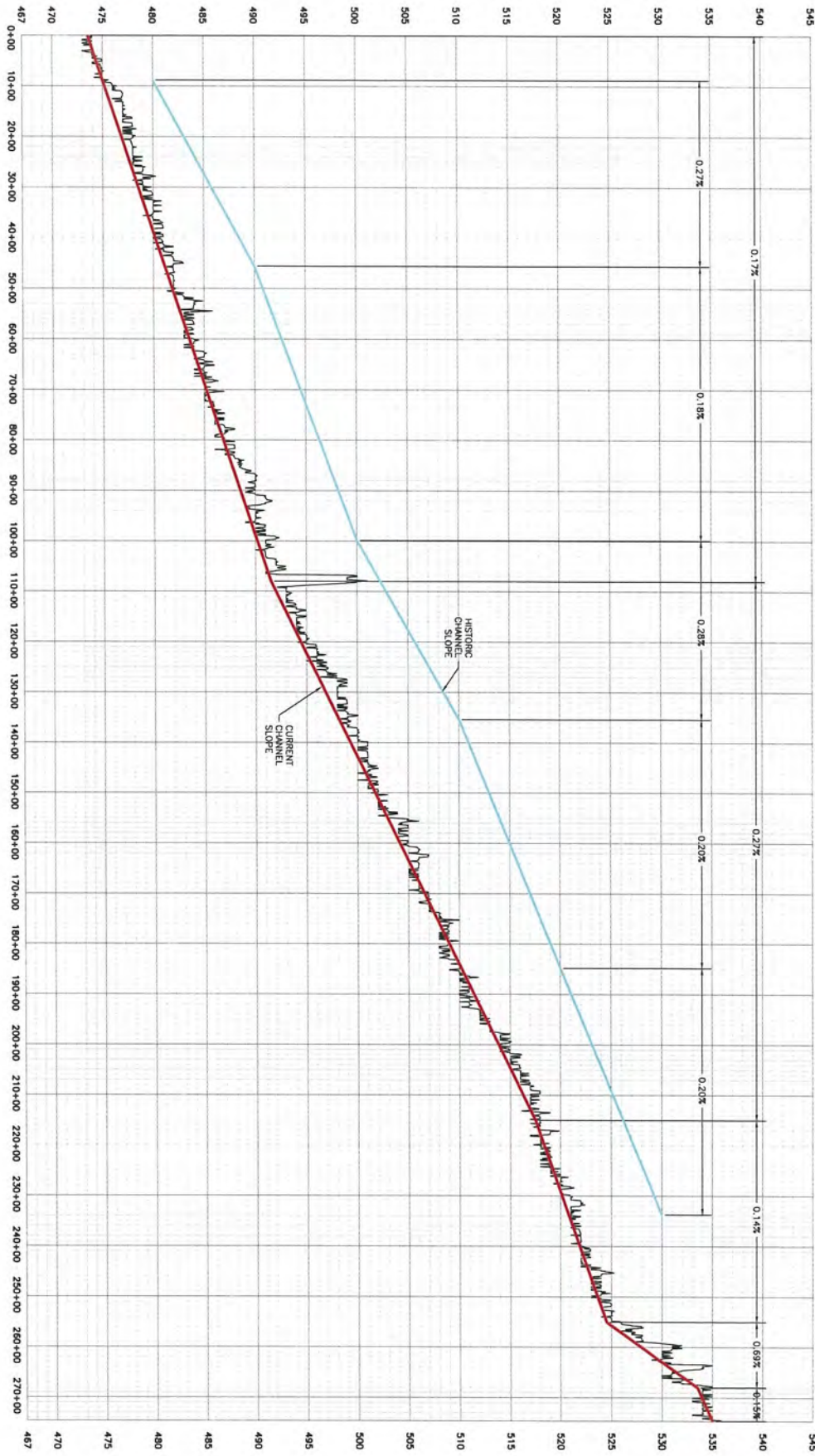

FIGURE 5.31



NORTH TEXAS MUNICIPAL WCID
LOWER BOIS D'ARC CREEK PROPOSED RESERVOIR PROJECT
 FLUMIAL GEOMORPHOLOGY
 WARD CREEK

F&N JOB NO.	NTD06128
DATE	1/25/08
SCALE	AS SHOWN
DESIGNED	JWS
DRAWN	CJE/GAL

FILE: WardHistoricOverlay.dwg



Figure 5.32 – Typical view of Ward Creek



Figure 5.33 - View of Ward Creek with evidence of mass wasting.

The dominant channel material is sand with some shale and gravel accumulations in the bar depositions. Between Stations 0+00 and 210+00, Ward Creek has an average top width of 115 feet, an average depth of 14 feet, with almost vertical side slopes. The riparian vegetation along the banks is dense, with a mix of small vines, brush, and trees along the lower and mid slopes and trees and grasses on the upper slope. Depositional side bars and point bars are common due to high sediment load but most of the reach is recovering and mass wasting is intermittent. There is good habitat potential along segments of this reach with 70% – 80% shade over the creek, in-stream vegetation and formation of a new floodplain within the channel. The remaining segments of the Creek have little habitat potential due to the lack of stream cover or shade. Upstream of Station 210+00 the average width of the channel is 80 feet with an average depth of 10 feet. With the exception of the segments from 233+00 to 237+00 and 255+00 to 268+00, the upper reach is similar to the lower reach. The 400 foot segment at Station 233+00 has been completely cleared for an overhead power easement and the 2007 aerial photographs indicate that the banks are actively wasting into the channel. The segment from Station 255+00 to 268+00 is between a knickpoint (a location in a river or channel where there is a sharp change in channel slope) in the channel profile and the upstream end of the channel incision. There is no physical barrier that forms the knickpoint, such as a culvert, and only riparian vegetation appears to be slowing the head cutting.

In terms of the rapid assessment classification of Ward Creek, the majority of the reaches of this creek appear to be in Type III or Type IV of the channel evolution process with inner berms forming within the channel. The downstream segment of this creek appears to be in Type III and continues to react to the changes in Bois d'Arc Creek. A major impact on this segment of the creek was the apparent meander cutoff at the confluence. The overhead electric easement and section downstream of the knickpoint are in Type III and Type II, respectively of the evolution process. The classification of this reach is predominantly fair, with approximately 84% of the reach given a "fair" rating and the remaining 16% a "poor" rating. The rapid geomorphic classification for this reach is presented as Figure 5.34.

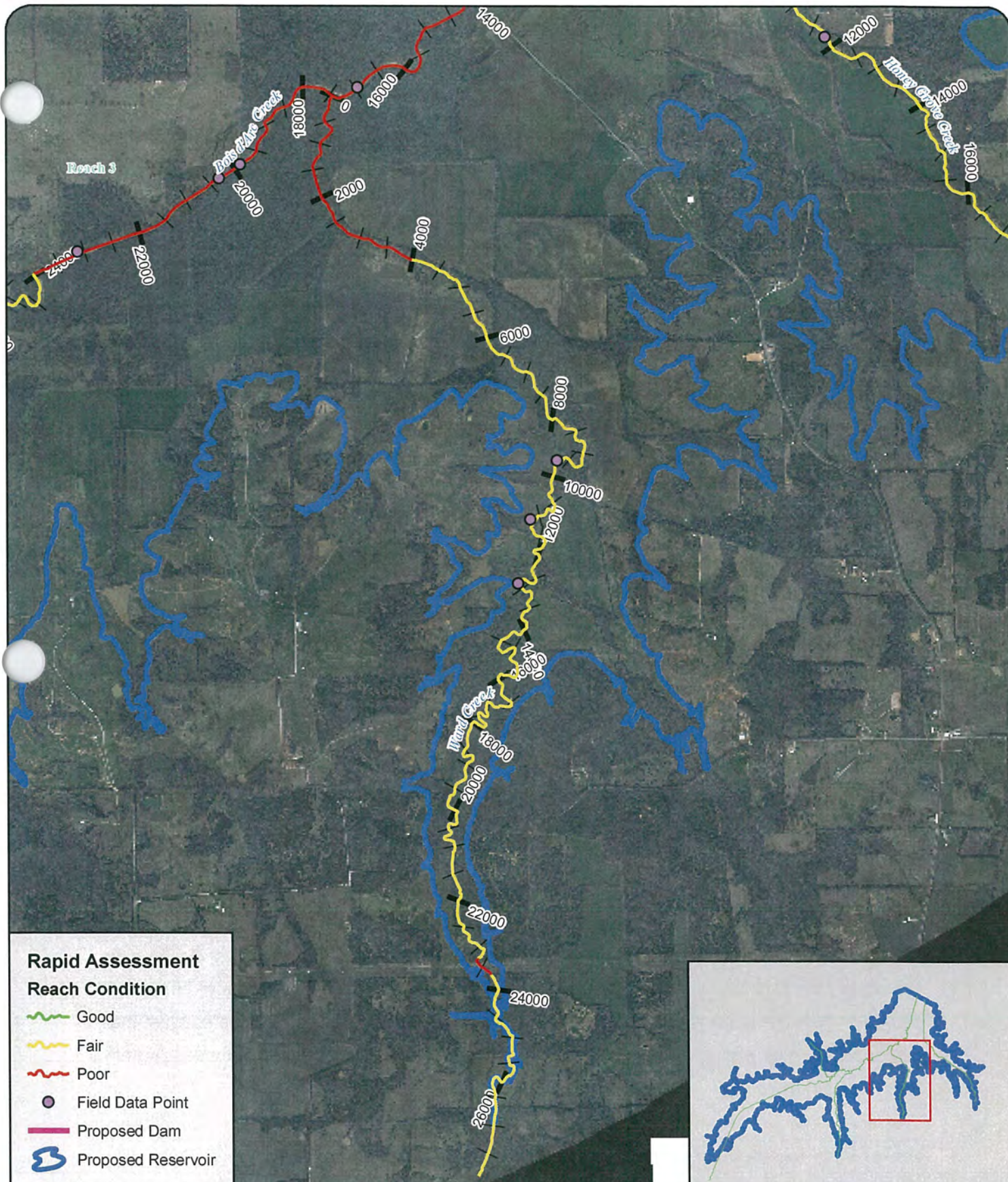

Rapid Assessment Reach Condition

- Good
- Fair
- Poor
- Field Data Point
- Proposed Dam
- Proposed Reservoir

PROJECT NO.	NTD06128
	September 2008
DATUM & COORDINATE SYSTEM	
	NAD83 State Plane
FILE	Fig5o34_Ward.mxd
PREPARED BY	JM

Freese and Nichols
 10814 Jollyville Road
 Building 4, Suite 100
 Austin, TX 78759
 Phone: (512) 617-3100
 Fax: (512) 617-3101

North Texas Municipal Water District
Proposed Lower Bois d'Arc Reservoir Project
Ward Creek

0 0.25 0.5 1
 Miles

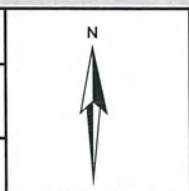

FIGURE
5.34

5.4 Bullard Creek

Bullard Creek is a large tributary of Bois d'Arc Creek with the stream confluence at approximate Station 345+00 on Bois d'Arc Creek. There are approximately 25,900 feet (4.9 miles) of Bullard Creek in the proposed inundation pool of Lower Bois d'Arc Reservoir. The 1915 map does not encompass the entire reach of Bullard Creek so we could not determine how much of the stream segment was channelized and straightened. However, estimates were made from the information available. Nearly 4,500 linear feet (20%) of Bullard Creek was channelized prior to 1950 (Figure 5.35). This channelization project actually redirected the lower reach of Bullard Creek through a minor tributary resulting in the abandonment of approximately 4,000 linear feet of the original Bullard Creek. The net effect was to channelize and enlarge approximately 8,000 linear feet (30%) of the existing Bullard Creek.

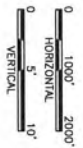
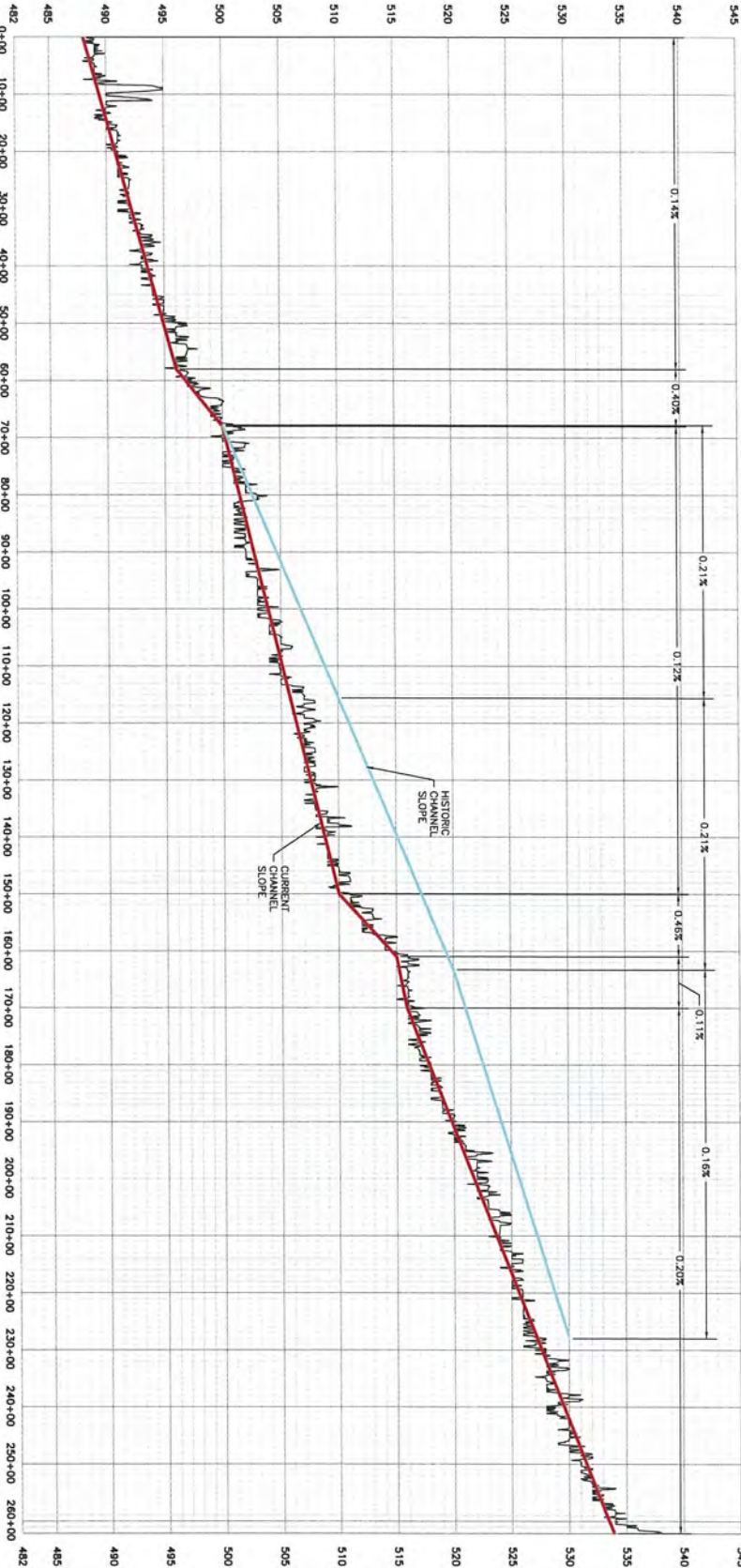

Figure 5.35 - Comparison of Historic to Existing Channel Alignment on Bullard Creek.

As depicted in Figure 5.36, the average slope of Bullard Creek is approximately 0.18% with variations from 0.11% to approximately 0.46%. There are two distinct knickpoints (STA. 68+00 and STA. 161+00) in the Bullard Creek longitudinal profile and field observations suggest that this creek is down cutting in response to the Bullard Creek diversion and down cutting within Bois d'Arc Creek proper.

The average top width of Bullard Creek is 90 feet with an average depth of 10 feet. The dominant channel material is clayey silt with some sand and gravel in the bars along the entire reach. Side bars and point bars are common with some mid-channels bars due to the moderate

STATIONING SHOWN IS RELATIVE
 TO CURRENT CREEK STATIONING



5.36
 FIGURE



NORTH TEXAS MUNICIPAL WCID
LOWER BOIS D'ARC CREEK PROPOSED RESERVOIR PROJECT
 FLUVIAL GEOMORPHOLOGY
BULLARD CREEK

PLAN JOB NO.	NT006128
DATE	1/25/08
SCALE	AS SHOWN
DESIGNED	JWS
DRAFTED	CJE/GAL

to high sediment load from the stream banks. Streambank erosion rates in some reaches appear to be very high due to mass wasting from the near vertical side slopes; however, there are some reaches that appear to be recovering with the formation of inner berms and emergent vegetation. Figure 5.37 shows an example of a stream segment classified as “poor.” Figure 5.38 shows an example of a stream segment in this area classified as “fair.”



Figure 5.37 - A “poor” rated stream on Bullard Creek.

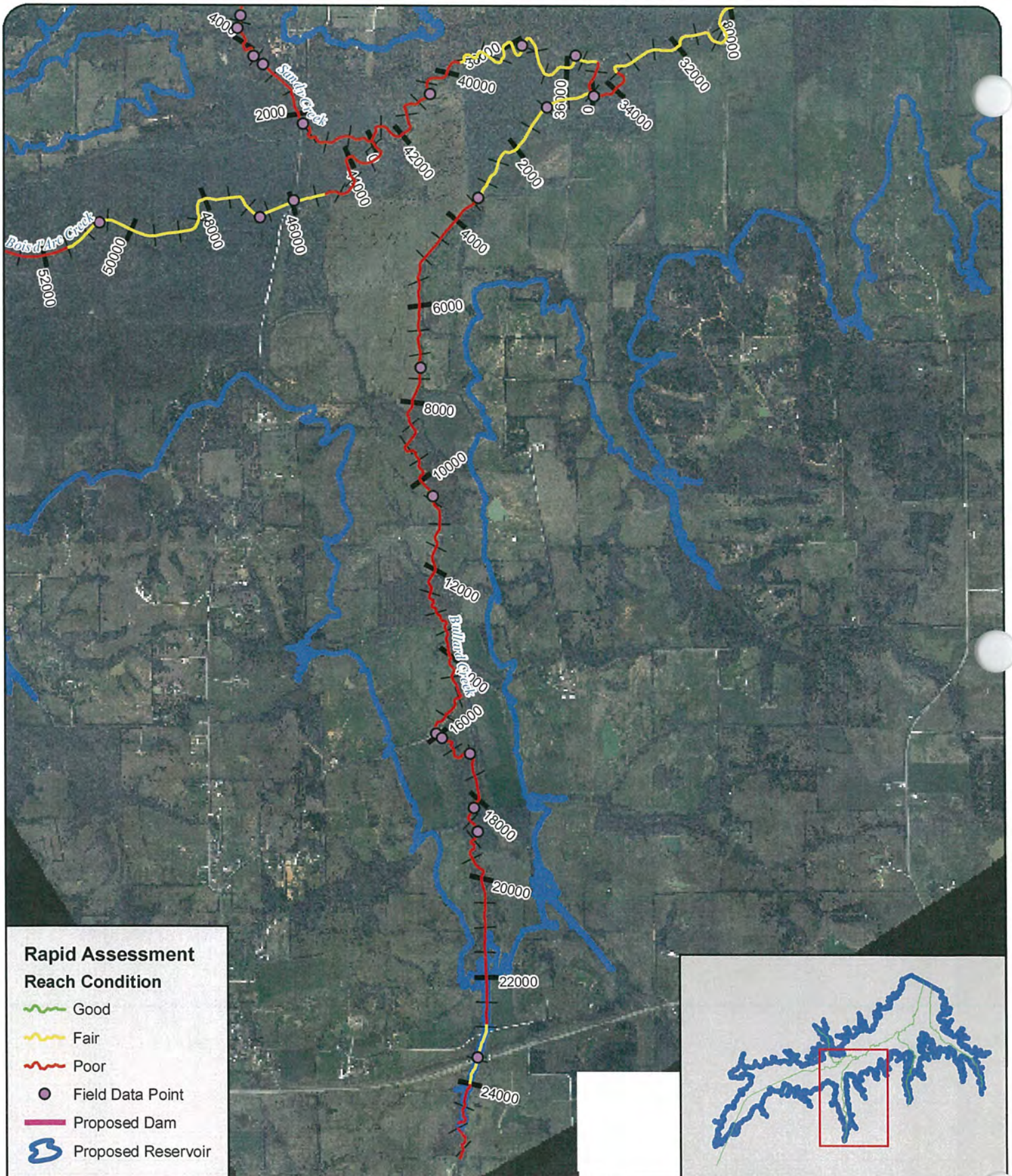

Figure 5.38 - A “fair” rated stream on Bullard Creek

As depicted in Figure 5.37, this channel is deeply incised with near vertical banks. There is limited vegetation along the side slopes but a dense stand of trees along the upper banks providing good stream cover. This reach seems to be in transition between Types II and III.



The stream conditions shown in Figure 5.37 look very similar to those shown in Figure 5.38; however this "fair" rated stream is showing signs of recovery by the development of the inner berm and floodplain and vegetation along the banks. This reach seems to be in Type IV.

The rapid geomorphic classification for Bullard Creek is presented as Figure 5.39. Bullard Creek is predominantly in fair stability conditions, with approximately 18% of the reach given a "fair" rating and the other 82% given a "poor" rating.

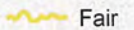

Rapid Assessment

Reach Condition

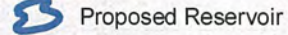
-  Good
-  Fair
-  Poor
-  Field Data Point
-  Proposed Dam
-  Proposed Reservoir

FN PROJECT NO.	NTD06128
DATE	September 2008
DATUM & COORDINATE SYSTEM	NAD83 State Plane
FILE	Fig5o39_Bullard.mxd
PREPARED BY	JM



Freese and Nichols
 10814 Jollyville Road
 Building 4, Suite 100
 Austin, TX 78759
 Phone: (512) 617-3100
 Fax: (512) 617-3101

North Texas Municipal Water District
Proposed Lower Bois d'Arc Reservoir Project

Bullard Creek

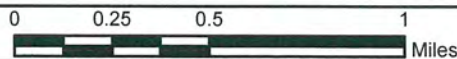

FIGURE
5.39

5.5 Sandy Creek

Sandy Creek is the only one of the four tributaries studied that is on the north side of Bois d'Arc Creek. Its confluence is at approximate Station 430+00 of Bois d'Arc Creek. Nearly 14,200 feet (2.7 miles) of Sandy Creek will be inundated by the proposed Lower Bois d'Arc Creek Reservoir.

The 1915 map does not encompass the entire reach of Sandy Creek so it was difficult to determine how much of the stream segment was channelized/straightened. From the 1950 aerial photographs, we estimated that approximately 2,200 linear feet (15%) of Sandy Creek, from Station 43+00 to 65+00 was channelized between 1915 and 1950 (Figure 5.40).



Figure 5.40 - Comparison of Historic to Existing Channel Alignment on Sandy Creek.

The dominant channel material is sand with some minor deposits of shale. There is a minor component of gravel material present on bars in the lower reach of the channel; however, it was unclear if this material was wash material from the channel or if it was gravel from the roads within the basin. Although there is some clay in the material along Sandy Creek, it appears to be a smaller component than the other tributaries and Bois d'Arc Creek. As observed in the aerial photographs, the channelization of Bois d'Arc Creek and alterations of Sandy Creek have resulted in down cutting from the confluence with Bois d'Arc Creek to well beyond the upstream end of the inundated reach of Sandy Creek. Aerial photographs show the head cut has extended to upstream of F.M. 1396, nearly 1.50 miles upstream of the proposed inundation pool.

The average slope of Sandy Creek is approximately 0.26% with variations from approximately 0.15% to approximately 0.43% (Figure 5.41). The average top width of Sandy Creek is 35 feet and the average depth is 8 feet, with the exception of two short segments from Station 97+00 to 108+00 and from Station 114+00 to 127+00. The average depth in these reaches is 8 feet like the rest of Sandy Creek but the top widths average 90 feet wide. The banks of the 35 foot wide stream segments are nearly vertical (Figure 5.42) while the banks along the two short reaches are much flatter (Figure 5.43). The riparian vegetation along the majority of the reach includes heavily wooded upper banks and terraces with almost no bank vegetation. There are occasional trees growing on the banks of the stream but the lack of any other vegetation is resulting in continued bank erosion, undercutting, and occasional mass wasting. Even where trees are present on the slopes, the bank material is being mined from beneath and between the roots. Due to the high sediment load from bank erosion and incision the depositional patterns within Sandy Creek include frequent side bars, point bars, and occasional transverse or mid-channel bars. The wooded terrace provides dense shade along most of Sandy Creek but due to the sediment load and near vertical banks there is little to no habitat potential within the channel.

The rapid geomorphic classification for Bullard Creek is presented as Figure 5.44. In terms of the rapid assessment classification, most of Sandy Creek appears to be Type III in the evolution process with two reaches that are Type IV. The continued widening of this creek indicates it is not in equilibrium. The classification for the majority of this stream is poor, with approximately 83% of the reach given a "poor" rating and the remainder rating "fair."

Station: Staip 10, 2008
 User: CJE
 File: V:\Work\Report\3\coverlay\coverlay.dwg

STATIONING SHOWN IS RELATIVE
 TO CURRENT CREEK STATIONING

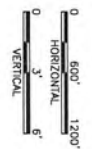
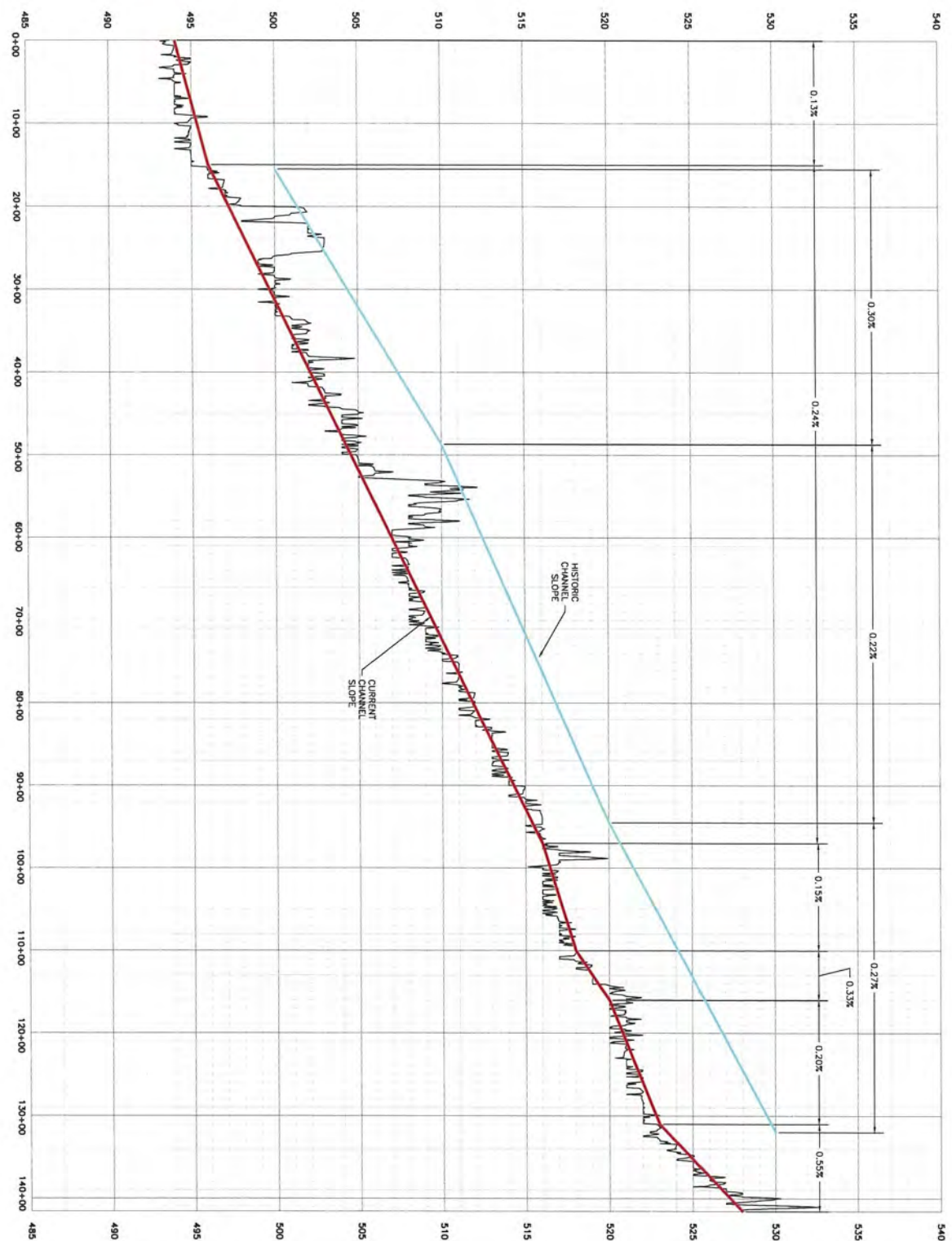

FIGURE 5.41



NORTH TEXAS MUNICIPAL WCID
 LOWER BOIS D'ARC CREEK PROPOSED RESERVOIR PROJECT
 FLUVIAL GEOMORPHOLOGY
 SANDY CREEK

PLAN JOB NO.	NTD06128
DATE	1/25/08
SCALE	AS SHOWN
DESIGNED	JWS
DRAFTED	CJE/GAL

FILE: SandyHistoricOverlay.dwg



Figure 5.42: Typical View of Sandy Creek with vertical side slopes.



Figures 5.43: Typical view of Sandy Creek with flatter side slopes.

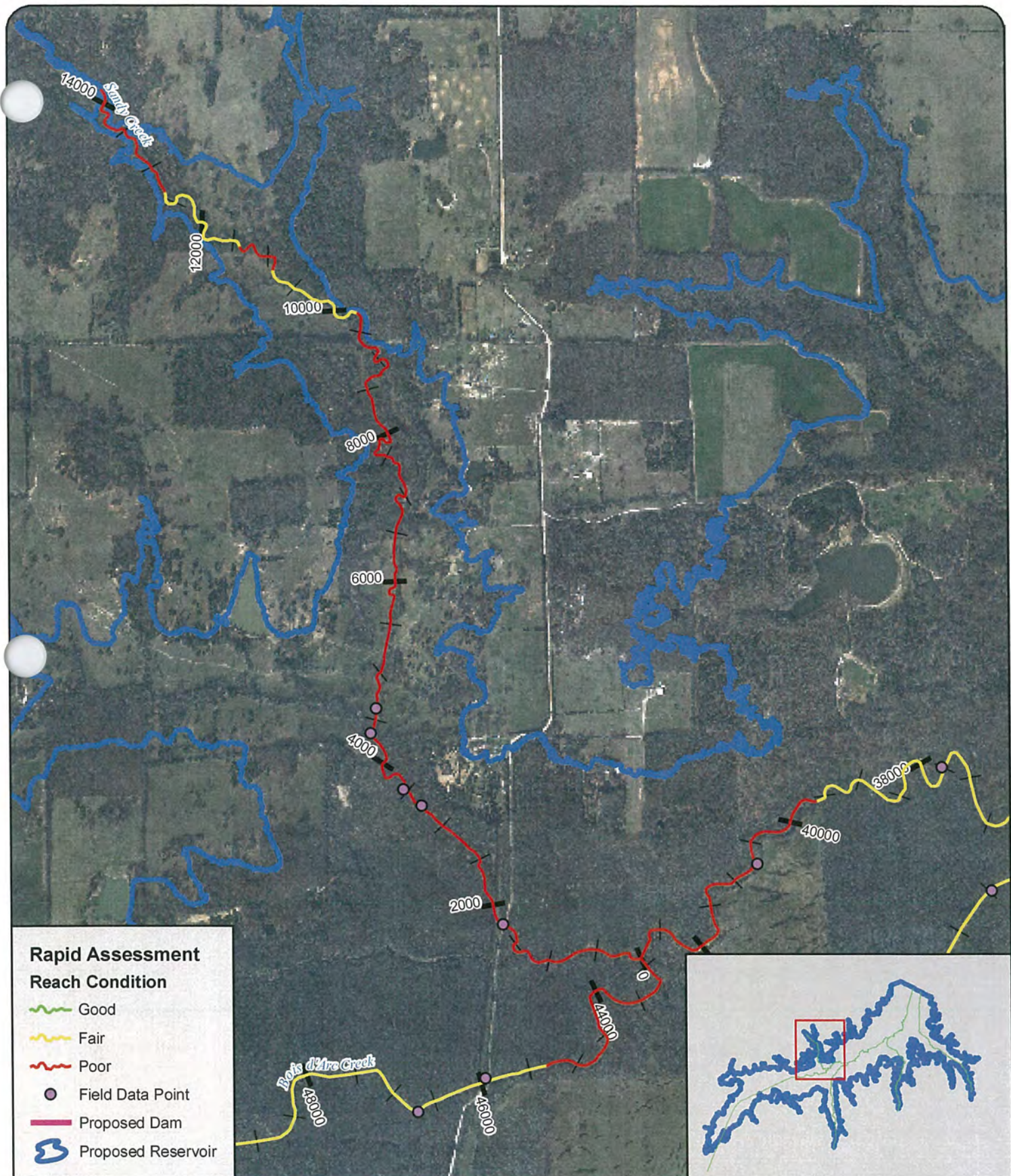

Rapid Assessment Reach Condition

- Good
- Fair
- Poor
- Field Data Point
- Proposed Dam
- Proposed Reservoir

PROJECT NO.	NTD06128
	September 2008
DATUM & COORDINATE SYSTEM	NAD83 State Plane
FILE	Fig5o44_Sandy.mxd
PREPARED BY	JM

Freese and Nichols
 10814 Jollyville Road
 Building 4, Suite 100
 Austin, TX 78759
 Phone: (512) 617-3100
 Fax: (512) 617-3101

North Texas Municipal Water District
Proposed Lower Bois d'Arc Reservoir Project
Sandy Creek

0 0.125 0.25 0.5
 Miles



FIGURE
5.44

5.6 Summary of Stream Classification

As outlined in Section 3.0, channelized streams in the southwest can take more than 100 years to complete the channel evolution cycle. Given the time-scales it is possible that some of the reaches within the Bois d'Arc Creek system that were altered in the early 20th Century have completed the channel evolution cycle and have re-established or are approaching dynamic equilibrium. No evidence of complete recovery was observed within the study area, likely due to the continued channel and vegetative modifications through the 1970's. Although there are reaches within the system that show signs that they are in the process of recovery, it is clear that there are a number of reaches that show signs of continued disequilibrium. Those reaches appear to be actively widening and show no signs of permanent benches or terraces forming within the channel at this time.

The following table summarizes the results of the Rapid Geomorphic Stability Assessment.

Table 5.2 – Channel Classification

Name	Classification	Reach Length (ft)	Percentage
Bois d’Arc Creek Reach 1	Total Reach	7,000	100%
	Good	-	0%
	Fair	3,587	51%
	Poor	3,413	49%
Bois d’Arc Creek Reach 2	Total Reach	12,000	100%
	Good	-	0%
	Fair	5,419	45%
	Poor	6,581	55%
Bois d’Arc Creek Reach 3	Total Reach	5,000	100%
	Good	-	0%
	Fair	50	1%
	Poor	4,950	99%
Bois d’Arc Creek Reach 4	Total Reach	24,500	100%
	Good	-	0%
	Fair	17,084	70%
	Poor	7,416	30%
Bois d’Arc Creek Reach 5	Total Reach	40,800	100%
	Good	-	0%
	Fair	15,200	37%
	Poor	25,600	63%
Bois d’Arc Creek Total	Total Reach	89,300	100%
	Good	-	0%
	Fair	41,340	46%
	Poor	47,960	54%
Honey Grove Creek	Total	35,700	100%
	Good	2,700	8%
	Fair	30,700	86%
	Poor	2,300	6%
Ward Creek	Total	27,900	100%
	Good	-	0%
	Fair	23,500	84%
	Poor	4,400	16%
Bullard Creek	Total	25,900	100%
	Good	-	0%
	Fair	4,600	18%
	Poor	21,300	82%
Sandy Creek	Total	14,150	100%
	Good	-	0%
	Fair	2,400	17%
	Poor	11,750	83%

Appendix A
Rapid Assessment Classification Forms

Bois d'Arc Creek and its Tributaries
Channel Stability Rating System

Reach: Bois D' Arc

Rapid Assessment Stream Stability Rating
 Excellent Good Fair Poor

Field Data Point	Station	
	To	From
BD36, 37	1290	
BD35	3414	

Extrapolated Stations		
To	From	Reasoning
0	1290	Same straightened reach; similar W, D, & S
1290	3414	Same land owner; identical aerial representation; similar channel W, D, & S; all straightened

Classification Basis Evaluation Category	Excellent (9 - 10)			Good (6 - 8)			Fair (3 - 5)			Poor (0 - 2)						
	Little to no evidence of bank sloughing, slumping, or failure. (< 10%)	Infrquent evidence of bank sloughing, slumping, or failure. Mostly healed over. (10-29.9%)	Infrequent evidence of bank sloughing, slumping, or failure. (20-39.9%)	Recent evidence of bank sloughing, slumping, or failure. High potential during flood events. (30-50%)	Banks comprised of highly erodible tree/plant/soil material	Moderate cover (40-69.9%) 2H:1V - 3H:1V	Moderate amount of mid-channel bars and side bars.	Banks comprised of highly erodible tree/plant/soil material and material is severely compromised.	Little to no cover (<10%) 1H:1V or steeper	Stream branching with mid-channel bars and islands or no depositional features.	Extensive amount of manmade channel alteration.	High evidence of bank sloughing, slumping, or failure. (>50%)	Banks comprised of highly erodible tree/plant/soil material and material is severely compromised.	Little to no cover (<10%) 1H:1V or steeper	Stream branching with mid-channel bars and islands or no depositional features.	Extensive amount of manmade channel alteration.
Evidence of Bank Erosion																
Bank Root Zone																
Vegetative Bank Cover																
Bank Angle																
Sediment Transport																
Channel Alteration																
Total																

Description: Sediment deposition along side of channel trying to create low flow. Limited vegetation on banks. No shrubs, lacking a good root zone. Undercut low banks. Deep pools, overhanging vegetation, and logs/brush present.
Class III

Score	Rapid Assessment Stream Stability Rating
51 - 60	Excellent Condition
37 - 50	Good Condition
20 - 36	Fair Condition
< 20	Poor Condition

Total Score 14



Bois d'Arc Creek and its Tributaries
Channel Stability Rating System

Reach: Bois D' Arc

Rapid Assessment Stream Stability Rating

Excellent
 Good
 Fair
 Poor

Field Data Point	Station	
	To	From
BD33	6660	
BD34		

Extrapolated Stations		Reasoning
To	From	
3414	6660	Similar W, D & S; same straightened reach; abandoned channel now serves as oxbows on left bank
6660	8500	Similar W, D & S; similar aerial representation

Classification Basis Evaluation Category	Excellent (9 - 10)		Good (6 - 8)		Fair (3 - 5)		Poor (0 - 2)	
	Little to no evidence of bank sloughing, slumping, or failure. (< 10%)	Banks comprised of highly resistant tree/plant/soil material.	Infrequent evidence of bank sloughing, slumping, or failure. Mostly healed over. (10-29.9%)	Banks comprised of moderately resistant tree/plant/soil material	Recent evidence of bank sloughing, slumping, or failure. High potential during flood events. (30-50%)	Banks comprised of highly erodible tree/plant/soil material and material is compromised.	Little to no cover (<10%)	High evidence of bank sloughing, slumping, or failure. (>50%)
Bank Root Zone								
Vegetative Bank Cover	Abundant cover (>70%)	Moderate cover (40-69.9%)						
Bank Angle	Point bars small and stable, well vegetated and/or armored with little or no fresh sand.	2H:1V - 3H:1V						
Sediment Transport	No manmade channel alteration.	Mix of point bars and few side bars.						
Channel Alteration		Infrequent amount of manmade channel alteration.						
Total			0	14	13	0	0	0

Description: Laid back slopes. Vegetated banks mixed with grasses and trees. Steeper undercut banks on outside bends of meanders. Minimal stream cover. Shallows, oxbows, deep pools, overhanging vegetation and logs/brush present. Class IV

Score	Rapid Assessment Stream Stability Rating
51 - 60	Excellent Condition
37 - 50	Good Condition
20 - 36	Fair Condition
< 20	Poor Condition

Total Score **27**



Bois d'Arc Creek and its Tributaries
Channel Stability Rating System

Reach: Bois d'Arc

Rapid Assessment Stream Stability Rating

Excellent
 Good
 Fair
 Poor

Field Data Point	To	Station	From
BD32	11350		11688

Extrapolated Stations		Reasoning
To	From	
8500	11350	Same meandering channel in aerial; same W, D & S; outside banks widening due to farm practices & lack of vegetation
23950	28370	Same tight meandering channel as downstream eroding outside bends by aerial with potential for widening

Classification Basis Evaluation Category	Excellent (9 - 10)		Good (6 - 8)		Fair (3 - 5)		Poor (0 - 2)	
	Evidence of Bank Erosion	Little to no evidence of bank sloughing, slumping, or failure. (< 10%)	Evidence of bank sloughing, slumping, or failure. Mostly healed over. (10-29.9%)	Infrequent evidence of bank sloughing, slumping, or failure. Recent evidence of bank sloughing, slumping, or failure. High potential during flood events. (30-50%)	Recent evidence of bank sloughing, slumping, or failure. High potential during flood events. (30-50%)	Recent evidence of bank sloughing, slumping, or failure. (>50%)	High evidence of bank sloughing, slumping, or failure. (>50%)	High evidence of bank sloughing, slumping, or failure. (>50%)
Bank Root Zone	Banks comprised of highly resistant tree/plant/soil material.	Banks comprised of moderately resistant tree/plant/soil material	Banks comprised of highly erodible tree/plant/soil material and material is compromised.	Banks comprised of highly erodible tree/plant/soil material and material is compromised.	Banks comprised of highly erodible tree/plant/soil material and material is severely compromised.	Banks comprised of highly erodible tree/plant/soil material and material is severely compromised.	Banks comprised of highly erodible tree/plant/soil material and material is severely compromised.	
Vegetative Bank Cover	Abundant cover (>70%)	Moderate cover (40-69.9%)	Infrequent cover (10-39.9%)	Infrequent cover (10-39.9%)	Little to no cover (<10%)	Little to no cover (<10%)	Little to no cover (<10%)	
Bank Angle	3H:1V or flatter	2H:1V - 3H:1V	1H:1V - 2H:1V	1H:1V - 2H:1V	1H:1V or steeper	1H:1V or steeper	1H:1V or steeper	
Sediment Transport	Point bars small and stable, well vegetated and/or armored with little or no fresh sand.	Mix of point bars and few side bars.	Moderate amount of mid-channel bars and side bars.	Moderate amount of mid-channel bars and side bars.	Stream branching with mid-channel bars and islands or no depositional features.	Stream branching with mid-channel bars and islands or no depositional features.	Stream branching with mid-channel bars and islands or no depositional features.	
Channel Alteration	No manmade channel alteration.	Infrequent amount of manmade channel alteration.	Moderate amount of manmade channel alteration.	Moderate amount of manmade channel alteration.	Extensive amount of manmade channel alteration.	Extensive amount of manmade channel alteration.	Extensive amount of manmade channel alteration.	
Total	0	13	7	13	5	13	2	

Description: More vegetation downstream of this area on banks. Appears to be stable, because not a lot of sediment in stream, but poor habitat potential. No vegetation on banks. Going from F → C. Undercut banks and little overhanging vegetation. Sediment accumulation and vegetation along channel toe indication of Class III (approaches IV) in channel evolution



Score	Rapid Assessment Stream Stability Rating
51 - 60	Excellent Condition
37 - 50	Good Condition
20 - 36	Fair Condition
< 20	Poor Condition



Total Score	28
-------------	----

Bois d'Arc Creek and its Tributaries
Channel Stability Rating System

Reach: Bois D' Arc

Rapid Assessment Stream Stability Rating

Excellent Good Fair Poor

Field Data Point	Station	
	To	From
BD30, BD31	11688	12229
BD27	12730	13159
BD26	13159	13259
BD24	13506	13706

Extrapolated Stations		
To	From	Reasoning

Classification Basis Evaluation Category	Good (6 - 8)			Fair (3 - 5)			Poor (0 - 2)		
	Excellent (9 - 10)	Good (6 - 8)	Fair (3 - 5)	Fair (3 - 5)	Fair (3 - 5)	Poor (0 - 2)	Poor (0 - 2)	Poor (0 - 2)	Poor (0 - 2)
Evidence of Bank Erosion	Little to no evidence of bank sloughing, slumping, or failure. (< 10%)	Infrequent evidence of bank sloughing, slumping, or failure. Mostly healed over. (10-29.9%)	Recent evidence of bank sloughing, slumping, or failure. High potential during flood events. (30-50%)	Recent evidence of bank sloughing, slumping, or failure. High potential during flood events. (30-50%)	Recent evidence of bank sloughing, slumping, or failure. High potential during flood events. (30-50%)	High evidence of bank sloughing, slumping, or failure. (>50%)	High evidence of bank sloughing, slumping, or failure. (>50%)	High evidence of bank sloughing, slumping, or failure. (>50%)	0
Bank Root Zone	Banks comprised of highly resistant tree/plant/soil material.	Banks comprised of moderately resistant tree/plant/soil material	Banks comprised of highly erodible tree/plant/soil material and material is severely compromised.	Banks comprised of highly erodible tree/plant/soil material and material is compromised.	Banks comprised of highly erodible tree/plant/soil material and material is severely compromised.	Banks comprised of highly erodible tree/plant/soil material and material is severely compromised.	Banks comprised of highly erodible tree/plant/soil material and material is severely compromised.	Banks comprised of highly erodible tree/plant/soil material and material is severely compromised.	2
Vegetative Bank Cover	Abundant cover (>70%)	Moderate cover (40-69.9%)	Infrequent cover (10-39.9%)	Infrequent cover (10-39.9%)	Infrequent cover (10-39.9%)	Little to no cover (<10%)	Little to no cover (<10%)	Little to no cover (<10%)	2
Bank Angle	3H:1V or flatter	2H:1V - 3H:1V	1H:1V - 2H:1V	1H:1V - 2H:1V	1H:1V - 2H:1V	Stream branching with mid-channel bars and islands or no depositional features.	Stream branching with mid-channel bars and islands or no depositional features.	Stream branching with mid-channel bars and islands or no depositional features.	2
Sediment Transport	Point bars small and stable, well vegetated and/or armored with little or no fresh sand.	Mix of point bars and few side bars.	Moderate amount of mid-channel bars and side bars.	Moderate amount of mid-channel bars and side bars.	Moderate amount of mid-channel bars and side bars.	4	4	4	
Channel Alteration	No manmade channel alteration.	Infrequent amount of manmade channel alteration.	Moderate amount of manmade channel alteration.	Moderate amount of manmade channel alteration.	Moderate amount of manmade channel alteration.	4	4	4	
Total	0	0	0	0	8	8	8	6	6

Description: Lots of potential for erodible sediment, deposition bars everywhere, limited vegetation on slopes, poor habitat potential, overhanging vegetation, Class IV

Score	Rapid Assessment Stream Stability Rating
51 - 60	Excellent Condition
37 - 50	Good Condition
20 - 36	Fair Condition
< 20	Poor Condition

Total Score **14**



Bois d'Arc Creek and its Tributaries
Channel Stability Rating System

Reach: Bois d'Arc

Rapid Assessment Stream Stability Rating

Excellent
 Good
 Fair
 Poor

Field Data Point	Station	
	To	From
BD28, BD29	12229	12730
BD25	13259	13506

Extrapolated Stations	
To	Reasoning

Classification Basis Evaluation Category	Good (6 - 8)			Fair (3 - 5)			Poor (0 - 2)		
	Excellent (9 - 10)	Good (6 - 8)	Fair (3 - 5)	Fair (3 - 5)	Fair (3 - 5)	Poor (0 - 2)	Poor (0 - 2)	Poor (0 - 2)	
Evidence of Bank Erosion	Little to no evidence of bank sloughing, slumping, or failure. (< 10%)	Infrequent evidence of bank sloughing, slumping, or failure. Mostly healed over. (10-29.9%)	Recent evidence of bank sloughing, slumping, or failure. High potential during flood events. (30-50%)	5	High evidence of bank sloughing, slumping, or failure. (>50%)				
Bank Root Zone	Banks comprised of highly resistant tree/plant/soil material.	Banks comprised of moderately resistant tree/plant/soil material	Banks comprised of highly erodible tree/plant/soil material and material is compromised.	4	Banks comprised of highly erodible tree/plant/soil material and material is severely compromised.				
Vegetative Bank Cover	Abundant cover (>70%)	Moderate cover (40-69.9%)	Infrequent cover (10-39.9%)	3	Little to no cover (<10%)				
Bank Angle	3H:1V or flatter	2H:1V - 3H:1V	1H:1V - 2H:1V		1H:1V or steeper			1	
Sediment Transport	Point bars small and stable, well vegetated and/or armored with little or no fresh sand.	Mix of point bars and few side bars.	Moderate amount of mid-channel bars and side bars.	5	Stream branching with mid-channel bars and islands or no depositional features.				
Channel Alteration	No manmade channel alteration.	Infrequent amount of manmade channel alteration.	Moderate amount of manmade channel alteration.	5	Extensive amount of manmade channel alteration.				
Total	0	0	0	22	 	 	 	1	

Description: Really steep banks with minimal cover → mostly grasses. Overhanging vegetation. Mid-channel bars. Class IV approaching Class V

Score	Rapid Assessment Stream Stability Rating
51 - 60	Excellent Condition
37 - 50	Good Condition
20 - 36	Fair Condition
< 20	Poor Condition

Total Score 23



Bois d'Arc Creek and its Tributaries
Channel Stability Rating System

Reach: Bois D' Arc

Rapid Assessment Stream Stability Rating

Excellent
 Good
 Fair
 Poor

Field Data Point	To	Station	From
BD22	13706		14961
BD23			

Extrapolated Stations		Reasoning
To	From	

Classification Basis Evaluation Category	Excellent (9 - 10)		Good (6 - 8)		Fair (3 - 5)		Poor (0 - 2)	
	Little to no evidence of bank sloughing, slumping, or failure. (< 10%)	Banks comprised of highly resistant tree/plant/soil material.	Infrequent evidence of bank sloughing, slumping, or failure. Mostly healed over. (10-29.9%)	Banks comprised of moderately resistant tree/plant/soil material	Recent evidence of bank sloughing, slumping, or failure. High potential during flood events. (30-50%)	Banks comprised of highly erodible tree/plant/soil material and material is severely compromised.	Little to no cover (<10%) 1H:1V or steeper	High evidence of bank sloughing, slumping, or failure. (>50%)
Bank Root Zone			6					
Vegetative Bank Cover	Abundant cover (>70%)		6					
Bank Angle	3H:1V or flatter							
Sediment Transport	Point bars small and stable, well vegetated and/or armored with little or no fresh sand.							
Channel Alteration	No manmade channel alteration.							
Total		0	12		6		0	

Description: Influence from bridge crossing. Deep pools, hanging vegetation, emergent/submergent vegetation, and logs/brush present. Class II or III

Score	Rapid Assessment Stream Stability Rating
51 - 60	Excellent Condition
37 - 50	Good Condition
20 - 36	Fair Condition
< 20	Poor Condition

Total Score **18**



Bois d'Arc Creek and its Tributaries
Channel Stability Rating System

Reach: Bois d'Arc

Rapid Assessment Stream Stability Rating

Excellent Good Fair Poor

Field Data Point	Station	
	To	From
BD21	16946	

Extrapolated Stations		
To	From	Reasoning
14961	19582	Identical aerial representation; same top width, bank slopes, & channel slope

Classification Basis Evaluation Category	Excellent (9 - 10)			Good (6 - 8)			Fair (3 - 5)			Poor (0 - 2)				
	Little to no evidence of bank sloughing, slumping, or failure. (< 10%)	Banks comprised of highly resistant tree/plant/soil material.	Abundant cover (>70%) 3H:1V or flatter	Infrequent evidence of bank sloughing, slumping, or failure. Mostly healed over. (10-29.9%)	Banks comprised of moderately resistant tree/plant/soil material	Moderate cover (40-69.9%) 2H:1V - 3H:1V	Recent evidence of bank sloughing, slumping, or failure. High potential during flood events. (30-50%)	Banks comprised of highly erodible tree/plant/soil material and material is compromised.	Infrequent cover (10-39.9%) 1H:1V - 2H:1V	Moderate amount of mid-channel bars and side bars.	Little to no cover (<10%) 1H:1V or steeper	High evidence of bank sloughing, slumping, or failure. (>50%)	Banks comprised of highly erodible tree/plant/soil material and material is severely compromised.	Stream branching with mid-channel bars and islands or no depositional features. Extensive amount of manmade channel alteration.
Bank Root Zone														1
Vegetative Bank Cover														1
Bank Angle														2
Sediment Transport														
Channel Alteration														
Total														4

Description: Sediment deposition in mid-channel. No stream cover. Sloughing and undercut banks. Trees from upper banks falling into creek and onto slope. Shallows, deep pools, overhanging vegetation and logs/brush present. Class III

Score	Rapid Assessment Stream Stability Rating
51 - 60	Excellent Condition
37 - 50	Good Condition
20 - 36	Fair Condition
< 20	Poor Condition

Total Score	13
-------------	----



Bois d'Arc Creek and its Tributaries
Channel Stability Rating System

Reach: Bois D' Arc

Rapid Assessment Stream Stability Rating

Excellent Good Fair Poor

Field Data Point	Station	
	To	From
	19618	19865

Extrapolated Stations	
To	Reasoning

Classification Basis Evaluation Category	Good (6 - 8)			Fair (3 - 5)			Poor (0 - 2)		
	Excellent (9 - 10)	Good (6 - 8)	Fair (3 - 5)	Fair (3 - 5)	Poor (0 - 2)	Poor (0 - 2)	Poor (0 - 2)	Poor (0 - 2)	Poor (0 - 2)
Evidence of Bank Erosion	Little to no evidence of bank sloughing, slumping, or failure. (< 10%)	Infrequent evidence of bank sloughing, slumping, or failure. Mostly healed over. (10-29.9%)	Recent evidence of bank sloughing, slumping, or failure. High potential during flood events. (30-50%)	Recent evidence of bank sloughing, slumping, or failure. High potential during flood events. (30-50%)	High evidence of bank sloughing, slumping, or failure. (>50%)	High evidence of bank sloughing, slumping, or failure. (>50%)	High evidence of bank sloughing, slumping, or failure. (>50%)	High evidence of bank sloughing, slumping, or failure. (>50%)	0
Bank Root Zone	Banks comprised of highly resistant tree/plant/soil material.	Banks comprised of moderately resistant tree/plant/soil material	Banks comprised of highly erodible tree/plant/soil material and material is compromised.	Banks comprised of highly erodible tree/plant/soil material and material is compromised.	Banks comprised of highly erodible tree/plant/soil material and material is severely compromised.	Banks comprised of highly erodible tree/plant/soil material and material is severely compromised.	Banks comprised of highly erodible tree/plant/soil material and material is severely compromised.	0	
Vegetative Bank Cover	Abundant cover (>70%)	Moderate cover (40-69.9%)	Infrequent cover (10-39.9%)	Infrequent cover (10-39.9%)	Little to no cover (<10%)	Little to no cover (<10%)	Little to no cover (<10%)	1	
Bank Angle	3H:1V or flatter	2H:1V - 3H:1V	1H:1V - 2H:1V	1H:1V - 2H:1V	1H:1V or steeper	1H:1V or steeper	1H:1V or steeper	1	
Sediment Transport	Point bars small and stable, well vegetated and/or armored with little or no fresh sand.	Mix of point bars and few side bars.	Moderate amount of mid-channel bars and side bars.	Moderate amount of mid-channel bars and side bars.	Stream branching with mid-channel bars and islands or no depositional features.	Stream branching with mid-channel bars and islands or no depositional features.	Stream branching with mid-channel bars and islands or no depositional features.	0	
Channel Alteration	No manmade channel alteration.	Infrequent amount of manmade channel alteration.	Moderate amount of manmade channel alteration.	Moderate amount of manmade channel alteration.	Extensive amount of manmade channel alteration.	Extensive amount of manmade channel alteration.	Extensive amount of manmade channel alteration.	0	
Total	0	6	6	6	0	0	0	2	

Description: High, steep banks → undercut, little to no vegetation, exposed sediment. Deep pools. overhanging vegetation and logs/brush present. Class III/IV

Score	Rapid Assessment Stream Stability Rating
51 - 60	Excellent Condition
37 - 50	Good Condition
20 - 36	Fair Condition
< 20	Poor Condition

Total Score	8
--------------------	----------



Bois d'Arc Creek and its Tributaries
Channel Stability Rating System

Reach: Bois d'Arc

Rapid Assessment Stream Stability Rating

Excellent
 Good
 Fair
 Poor

Field Data Point	To	Station	From
BD20	19865		20309

Extrapolated Stations		
To	From	Reasoning

Classification Basis Evaluation Category	Excellent (9 - 10)		Good (6 - 8)		Fair (3 - 5)		Poor (0 - 2)	
	Little to no evidence of bank sloughing, slumping, or failure. (< 10%)	Banks comprised of highly resistant tree/plant/soil material.	Infrequent evidence of bank sloughing, slumping, or failure. Mostly healed over. (10-29.9%)	Banks comprised of moderately resistant tree/plant/soil material	Recent evidence of bank sloughing, slumping, or failure. High potential during flood events. (30-50%)	Banks comprised of highly erodible tree/plant/soil material and material is compromised.	High evidence of bank sloughing, slumping, or failure. (>50%)	
Bank Root Zone								
Vegetative Bank Cover	Abundant cover (>70%)		Moderate cover (40-69.9%)		Infrequent cover (10-39.9%)		Little to no cover (<10%)	
Bank Angle	3H:1V or flatter		2H:1V - 3H:1V		1H:1V - 2H:1V		1H:1V or steeper	0
Sediment Transport	Point bars small and stable, well vegetated and/or armored with little or no fresh sand.		Mix of point bars and few side bars.		Moderate amount of mid-channel bars and side bars.		Stream branching with mid-channel bars and islands or no depositional features.	
Channel Alteration	No manmade channel alteration.		Infrequent amount of manmade channel alteration.		Moderate amount of manmade channel alteration.		Extensive amount of manmade channel alteration.	0
Total		0		0		18		0

Description: F → C Reach has been straightened, but it's trying to stabilize itself by depositing sediment and forming bars. Class III → IV

Score	Rapid Assessment Stream Stability Rating
51 - 60	Excellent Condition
37 - 50	Good Condition
20 - 36	Fair Condition
< 20	Poor Condition

Total Score	18
-------------	----



Bois d'Arc Creek and its Tributaries
Channel Stability Rating System

Reach: Bois D' Arc

Rapid Assessment Stream Stability Rating

Excellent
 Good
 Fair
 Poor

Field Data Point	To	Station	From
BD18	23109		
BD19			

Extrapolated Stations		
To	From	Reasoning
20309	23950	Similar W,D & S; same aerial representation and straightened reach

Classification Basis					
Evaluation Category	Excellent (9 - 10)	Good (6 - 8)	Fair (3 - 5)	Poor (0 - 2)	
Evidence of Bank Erosion	Little to no evidence of bank sloughing, slumping, or failure. (< 10%)	Infrequent evidence of bank sloughing, slumping, or failure. Mostly healed over. (10-29.9%)	Recent evidence of bank sloughing, slumping, or failure. High potential during flood events. (30-50%)	High evidence of bank sloughing, slumping, or failure. (>50%)	0
Bank Root Zone	Banks comprised of highly resistant tree/plant/soil material.	Banks comprised of moderately resistant tree/plant/soil material	Banks comprised of highly erodible tree/plant/soil material and material is compromised.	Banks comprised of highly erodible tree/plant/soil material and material is severely compromised.	2
Vegetative Bank Cover	Abundant cover (>70%)	Moderate cover (40-69.9%)	Infrequent cover (10-39.9%)	Little to no cover (<10%)	2
Bank Angle	3H:1V or flatter	2H:1V - 3H:1V	1H:1V - 2H:1V	1H:1V or steeper	2
Sediment Transport	Point bars small and stable, well vegetated and/or armored with little or no fresh sand.	Mix of point bars and few side bars.	Moderate amount of mid-channel bars and side bars.	Stream branching with mid-channel bars and islands or no depositional features.	0
Channel Alteration	No manmade channel alteration.	Infrequent amount of manmade channel alteration.	Moderate amount of manmade channel alteration.	Extensive amount of manmade channel alteration.	0
Total	0	6	4	4	4

Description: 2-3 times wider than point at confluence with Bullard. Lots of bank sloughing, limited stream cover. Exposed sediment. Straightened segment with little to no vegetation on left overbank. Undercut banks, overhanging vegetation and logs/brush present. Class III

Score	Rapid Assessment Stream Stability Rating
51 - 60	Excellent Condition
37 - 50	Good Condition
20 - 36	Fair Condition
< 20	Poor Condition

Total Score 14



Bois d'Arc Creek and its Tributaries
Channel Stability Rating System

Reach: Bois d'Arc

Rapid Assessment Stream Stability Rating

Excellent
 Good
 Fair
 Poor

Field Data Point	Station	
	To	From
BD17	29602	

Extrapolated Stations		
To	From	Reasoning
28370	30000	Straightened portion of reach; similar topography, aerial; original creek is now oxbows
30000	33500	Similar channel width, depth, slope & pattern; same vegetation by aerial

Classification Basis Evaluation Category	Good (6 - 8)			Fair (3 - 5)		Poor (0 - 2)	
	Excellent (9 - 10)	Good (6 - 8)	Fair (3 - 5)	Fair (3 - 5)	Poor (0 - 2)	Poor (0 - 2)	Poor (0 - 2)
Evidence of Bank Erosion	Little to no evidence of bank sloughing, slumping, or failure. (< 10%)	Infrequent evidence of bank sloughing, slumping, or failure. Mostly healed over. (10-29.9%)	Recent evidence of bank sloughing, slumping, or failure. High potential during flood events. (30-50%)	3	3	High evidence of bank sloughing, slumping, or failure. (>50%)	
Bank Root Zone	Banks comprised of highly resistant tree/plant/soil material.	Banks comprised of moderately resistant tree/plant/soil material	Banks comprised of highly erodible tree/plant/soil material and material is compromised.	3	3	Banks comprised of highly erodible tree/plant/soil material and material is severely compromised.	
Vegetative Bank Cover	Abundant cover (>70%)	Moderate cover (40-69.9%)	Infrequent cover (10-39.9%)	6	6	Little to no cover (<10%)	
Bank Angle	3H:1V or flatter	2H:1V - 3H:1V	1H:1V - 2H:1V	8	8	1H:1V or steeper	
Sediment Transport	Point bars small and stable, well vegetated and/or armored with little or no fresh sand.	Mix of point bars and few side bars.	Moderate amount of mid-channel bars and side bars.	8	8	Stream branching with mid-channel bars and islands or no depositional features.	
Channel Alteration	No manmade channel alteration.	Infrequent amount of manmade channel alteration.	Moderate amount of manmade channel alteration.	14	14	Extensive amount of manmade channel alteration.	0
Total	0	14	14	11	11	0	0

Description: High flood event during visit. Hard to see banks and creek bottom. A lot of vegetation on top of banks, but little on slopes itself. Undercut and steep banks with some roots. Oxbows, deep pools, overhanging vegetation, and logs/brush present. Class III

Score	Rapid Assessment Stream Stability Rating
51 - 60	Excellent Condition
37 - 50	Good Condition
20 - 36	Fair Condition
< 20	Poor Condition

Total Score 25



Bois d'Arc Creek and its Tributaries
Channel Stability Rating System

Reach: Bois D' Arc

Rapid Assessment Stream Stability Rating

Excellent Good Fair Poor

Field Data Point	Station	
	To	From
BD16	34443	

Extrapolated Stations		
To	From	Reasoning
33500	35200	Reach through meander where S, W & D are similar

Evaluation Category	Classification Basis			Fair (3 - 5)	Poor (0 - 2)
	Excellent (9 - 10)	Good (6 - 8)	Fair (3 - 5)		
Evidence of Bank Erosion	Little to no evidence of bank sloughing, slumping, or failure. (< 10%)	Infrequent evidence of bank sloughing, slumping, or failure. Mostly healed over. (10-29.9%)	Recent evidence of bank sloughing, slumping, or failure. High potential during flood events. (30-50%)		High evidence of bank sloughing, slumping, or failure. (>50%)
Bank Root Zone	Banks comprised of highly resistant tree/plant/soil material.	Banks comprised of moderately resistant tree/plant/soil material	Banks comprised of highly erodible tree/plant/soil material and material is compromised.		Banks comprised of highly erodible tree/plant/soil material and material is severely compromised.
Vegetative Bank Cover	Abundant cover (>70%)	Moderate cover (40-69.9%)	Infrequent cover (10-39.9%)		Little to no cover (<10%)
Bank Angle	3H:1V or flatter	2H:1V - 3H:1V	1H:1V - 2H:1V	3	1H:1V or steeper
Sediment Transport	Point bars small and stable, well vegetated and/or armored with little or no fresh sand.	Mix of point bars and few side bars.	Moderate amount of mid-channel bars and side bars.	3	Stream branching with mid-channel bars and islands or no depositional features.
Channel Alteration	No manmade channel alteration.	Infrequent amount of manmade channel alteration.	Moderate amount of manmade channel alteration.		Extensive amount of manmade channel alteration.
Total	10	0	6	6	1

Description: Evidence of high bank sloughing. Exposed roots and barren slopes outside of trees. Deposition in mid-channel and on side. Undercut banks. Shallows, deep pools, overhanging vegetation and logs/brush present

Score	Rapid Assessment Stream Stability Rating
51 - 60	Excellent Condition
37 - 50	Good Condition
20 - 36	Fair Condition
< 20	Poor Condition

Total Score **17**



Bois d'Arc Creek and its Tributaries
Channel Stability Rating System

Reach: Bois D' Arc

Rapid Assessment Stream Stability Rating

Excellent
 Good
 Fair
 Poor

Field Data Point	To	Station	From
BD14	35661		37500
BD15			

Extrapolated Stations		Reasoning
To	From	
35200	35661	Same channel width, depth, slope and pattern; same aerial representation
37500	39608	Same channel width, depth, and slope; lighter meanders; evidence of sloughing and similar vegetation in aerial

Classification Basis Evaluation Category	Excellent (9 - 10)		Good (6 - 8)		Fair (3 - 5)		Poor (0 - 2)	
	Little to no evidence of bank sloughing, slumping, or failure. (< 10%)	Banks comprised of highly resistant tree/plant/soil material.	Infrequent evidence of bank sloughing, slumping, or failure. Mostly healed over. (10-29.9%)	Banks comprised of moderately resistant tree/plant/soil material	Recent evidence of bank sloughing, slumping, or failure. High potential during flood events. (30-50%)	Banks comprised of highly erodible tree/plant/soil material and material is compromised.	High evidence of bank sloughing, slumping, or failure. (>50%)	
Bank Root Zone								
Vegetative Bank Cover	Abundant cover (>70%)		Moderate cover (40-69.9%)		Infrequent cover (10-39.9%)		Little to no cover (<10%)	
Bank Angle	3H:1V or flatter		2H:1V - 3H:1V		1H:1V - 2H:1V		1H:1V or steeper	2
Sediment Transport	Point bars small and stable, well vegetated and/or armored with little or no fresh sand.		Mix of point bars and few side bars.	6	Moderate amount of mid-channel bars and side bars.		Stream branching with mid-channel bars and islands or no depositional features.	
Channel Alteration	No manmade channel alteration.	10	Infrequent amount of manmade channel alteration.		Moderate amount of manmade channel alteration.		Extensive amount of manmade channel alteration.	
Total		10		6		10		2

Description: Good cover over creek. Little to no vegetation on banks. Trees on top of banks. Undercut banks. Shallows, deep pools, overhanging vegetation and logs/brush present

Score	Rapid Assessment Stream Stability Rating
51 - 60	Excellent Condition
37 - 50	Good Condition
20 - 36	Fair Condition
< 20	Poor Condition

Total Score 28



Bois d'Arc Creek and its Tributaries
Channel Stability Rating System

Reach: Bois d'Arc

Rapid Assessment Stream Stability Rating

Excellent
 Good
 Fair
 Poor

Field Data Point	To	Station	From
BD13	40728		

Extrapolated Stations			Reasoning
To	From		
39608	42115		Same aerial & topographic conditions
42215	45323		Similar channel pattern; same channel properties (width, depth, slope); more vegetation on right bank

Classification Basis Evaluation Category	Excellent (9 - 10)			Good (6 - 8)		Fair (3 - 5)		Poor (0 - 2)		
	Little to no evidence of bank sloughing, slumping, or failure. (< 10%)	Banks comprised of highly resistant tree/plant/soil material.	Abundant cover (>70%) 3H:1V or flatter Point bars small and stable, well vegetated and/or armored with little or no fresh sand. No manmade channel alteration.	Infrequent evidence of bank sloughing, slumping, or failure. Mostly healed over. (10-29.9%)	Banks comprised of moderately resistant tree/plant/soil material	Moderate cover (40-69.9%) 2H:1V - 3H:1V Mix of point bars and few side bars.	Infrequent amount of manmade channel alteration.	Recent evidence of bank sloughing, slumping, or failure. High potential during flood events. (30-50%)	Banks comprised of highly erodible tree/plant/soil material and material is compromised.	Little to no cover (<10%) 1H:1V or steeper Stream branching with mid-channel bars and islands or no depositional features. Extensive amount of manmade channel alteration.
Evidence of Bank Erosion										1
Bank Root Zone										2
Vegetative Bank Cover										2
Bank Angle										3
Sediment Transport										5
Channel Alteration										8
Total										6
										0
										8
										5

Description: No substantial vegetation on right bank causing bank sloughing. Back eddies occurring due to sediment deposition. Undercut banks with mass wasting. No stream cover. Shallows, deep pools, overhanging vegetation and logs/brush present. Class IV

Score	Rapid Assessment Stream Stability Rating
51 - 60	Excellent Condition
37 - 50	Good Condition
20 - 36	Fair Condition
< 20	Poor Condition

Total Score **19**



Bois d'Arc Creek and its Tributaries
Channel Stability Rating System

Reach: Bois d'Arc

Rapid Assessment Stream Stability Rating

Excellent
 Good
 Fair
 Poor

Field Data Point	Station	
	To	From
BD11	46696	
BD12	45951	

Extrapolated Stations		Reasoning
To	From	
45323	46696	Straightened reach from bridge crossing

Classification Basis	Evaluation Category			Fair (3 - 5)	Poor (0 - 2)
	Excellent (9 - 10)	Good (6 - 8)	Fair (3 - 5)		
Evidence of Bank Erosion	Little to no evidence of bank sloughing, slumping, or failure. (< 10%)	Infrequent evidence of bank sloughing, slumping, or failure. Mostly healed over. (10-29.9%)	Recent evidence of bank sloughing, slumping, or failure. High potential during flood events. (30-50%)	5	High evidence of bank sloughing, slumping, or failure. (>50%)
Bank Root Zone	Banks comprised of highly resistant tree/plant/soil material.	Banks comprised of moderately resistant tree/plant/soil material	Banks comprised of highly erodible tree/plant/soil material and material is compromised.	5	Banks comprised of highly erodible tree/plant/soil material and material is severely compromised.
Vegetative Bank Cover	Abundant cover (>70%)	Moderate cover (40-69.9%)	Infrequent cover (10-39.9%)		Little to no cover (<10%)
Bank Angle	3H:1V or flatter	2H:1V - 3H:1V	1H:1V - 2H:1V		1H:1V or steeper
Sediment Transport	Point bars small and stable, well vegetated and/or armored with little or no fresh sand.	Mix of point bars and few side bars.	Moderate amount of mid-channel bars and side bars.	9	Stream branching with mid-channel bars and islands or no depositional features.
Channel Alteration	No manmade channel alteration.	Infrequent amount of manmade channel alteration.	Moderate amount of manmade channel alteration.	5	Extensive amount of manmade channel alteration.
Total	9	7	7	15	2

Description: This is beginning of straightened reach due to road crossing. Good stream cover and mix of vegetated species. Sleep, undercut banks. Milky water. Deposition in creek. Deep pools, overhanging vegetation and logs/brush present

Score	Rapid Assessment Stream Stability Rating
51 - 60	Excellent Condition
37 - 50	Good Condition
20 - 36	Fair Condition
< 20	Poor Condition

Total Score **33**



Bois d'Arc Creek and its Tributaries
Channel Stability Rating System

Reach: Bois D' Arc

Rapid Assessment Stream Stability Rating

Excellent Good Fair Poor

Field Data Point	To	Station	From
BD09	57000		

Extrapolated Stations		Reasoning
To	From	
51500	60298	Similar stream characteristics → steep banks, incised, straightened

Classification Basis Evaluation Category	Excellent (9 - 10)		Good (6 - 8)		Fair (3 - 5)		Poor (0 - 2)	
	Evidence of Bank Erosion	Little to no evidence of bank sloughing, slumping, or failure. (< 10%)	Infrequent evidence of bank sloughing, slumping, or failure. Mostly healed over. (10-29.9%)	Recent evidence of bank sloughing, slumping, or failure. High potential during flood events. (30-50%)	High evidence of bank sloughing, slumping, or failure. (>50%)			
Bank Root Zone	Banks comprised of highly resistant tree/plant/soil material.	Banks comprised of moderately resistant tree/plant/soil material	Banks comprised of highly erodible tree/plant/soil material and material is compromised.	Banks comprised of highly erodible tree/plant/soil material and material is severely compromised.				2
Vegetative Bank Cover	Abundant cover (>70%)	Moderate cover (40-69.9%)	Infrequent cover (10-39.9%)	Little to no cover (<10%)				1
Bank Angle	3H:1V or flatter	2H:1V - 3H:1V	1H:1V - 2H:1V	1H:1V or steeper				1
Sediment Transport	Point bars small and stable, well vegetated and/or armored with little or no fresh sand.	Mix of point bars and few side bars.	Moderate amount of mid-channel bars and side bars.	Stream branching with mid-channel bars and islands or no depositional features.				0
Channel Alteration	No manmade channel alteration.	Infrequent amount of manmade channel alteration.	Moderate amount of manmade channel alteration.	Extensive amount of manmade channel alteration.				0
Total	0	0	0	3	3	0	4	4

Description: High, vertical banks with limited cover. Tree root mass cover 1/2 bank height. Undercut low banks and high banks. Good stream cover in spring/summer. Milky water. Shallows, overhanging vegetation and logs/brush present. Class II

Score	Rapid Assessment Stream Stability Rating
51 - 60	Excellent Condition
37 - 50	Good Condition
20 - 36	Fair Condition
< 20	Poor Condition

Total Score 7



Bois d'Arc Creek and its Tributaries
Channel Stability Rating System

Reach: Bois d' Arc

Rapid Assessment Stream Stability Rating

Excellent
 Good
 Fair
 Poor

Field Data Point	To	Station	From
BD05	65738		
BD06	62145		
BD07	60420		
BD08	60298		
BD10	50672		

Extrapolated Stations		To	From	Reasoning
		60298	65738	Several data points between representing same conditions; identical aerial
		46896	51500	Good likeness to historical aerial; laid back slopes; similar aerial representation

Classification Basis Evaluation Category	Excellent (9 - 10)		Good (6 - 8)		Fair (3 - 5)		Poor (0 - 2)	
	Little to no evidence of bank sloughing, slumping, or failure. (< 10%)	Banks comprised of highly resistant tree/plant/soil material.	Infrequent evidence of bank sloughing, slumping, or failure. Mostly healed over. (10-29.9%)	Banks comprised of moderately resistant tree/plant/soil material	Recent evidence of bank sloughing, slumping, or failure. High potential during flood events. (30-50%)	Banks comprised of highly erodible tree/plant/soil material and material is severely compromised.	Little to no cover (<10%) 1H:1V or steeper	High evidence of bank sloughing, slumping, or failure. (>50%)
Bank Root Zone			9			5		
Vegetative Bank Cover	Abundant cover (>70%) 3H:1V or flatter					5		
Bank Angle	Point bars small and stable, well vegetated and/or armored with little or no fresh sand.		8					
Sediment Transport	No manmade channel alteration.		6					
Channel Alteration							0	
Total			9				10	0

Description: Good variety of vegetation- trees, shrubs, grass. Decent stream cover along banks of creek. High flows, hard to note deposition, but very milky water--> high sediment load. Study bank = bankfull, so low stress banks and use of floodplain. Undercut banks. Deep pools, overhanging vegetation and logs/brush

Score	Rapid Assessment Stream Stability Rating
51 - 60	Excellent Condition
37 - 50	Good Condition
20 - 36	Fair Condition
< 20	Poor Condition

Total Score 33



Bois d'Arc Creek and its Tributaries
Channel Stability Rating System

Reach: Bois d'Arc

Rapid Assessment Stream Stability Rating

Excellent
 Good
 Fair
 Poor

Field Data Point	To	Station	From
BD04	69536		

Extrapolated Stations			
To	From	Reasoning	
69171	69635	Within same utility easement; matching aerial and topography	

Evaluation Category	Classification Basis			Fair (3 - 5)	Poor (0 - 2)
	Excellent (9 - 10)	Good (6 - 8)	Fair (3 - 5)		
Evidence of Bank Erosion	Little to no evidence of bank sloughing, slumping, or failure. (< 10%)	Infrequent evidence of bank sloughing, slumping, or failure. Mostly healed over. (10-29.9%)	Recent evidence of bank sloughing, slumping, or failure. High potential during flood events. (30-50%)	High evidence of bank sloughing, slumping, or failure. (>50%)	
Bank Root Zone	Banks comprised of highly resistant tree/plant/soil material.	Banks comprised of moderately resistant tree/plant/soil material	Banks comprised of highly erodible tree/plant/soil material and material is compromised.	Banks comprised of highly erodible tree/plant/soil material and material is severely compromised.	5
Vegetative Bank Cover	Abundant cover (>70%)	Moderate cover (40-69.9%)	Infrequent cover (10-39.9%)	Little to no cover (<10%)	2
Bank Angle	3H:1V or flatter	2H:1V - 3H:1V	1H:1V - 2H:1V	1H:1V or steeper	0
Sediment Transport	Point bars small and stable, well vegetated and/or armored with little or no fresh sand.	Mix of point bars and few side bars.	Moderate amount of mid-channel bars and side bars.	Stream branching with mid-channel bars and islands or no depositional features.	0
Channel Alteration	No manmade channel alteration.	Infrequent amount of manmade channel alteration.	Moderate amount of manmade channel alteration.	Extensive amount of manmade channel alteration.	0
Total	9	8	5	2	2

Description: Utility easement. Farm fields right up to limits of creek taking out all vegetation except grasses. One bank looking upstream has trees on top of bank, but slope is undercut with no vegetation. Steep slopes. No stream cover. Shallows, deep pools, overhanging vegetation and logs/brush present.

Score	Rapid Assessment Stream Stability Rating
51 - 60	Excellent Condition
37 - 50	Good Condition
20 - 36	Fair Condition
< 20	Poor Condition

Total Score 24



Bois d'Arc Creek and its Tributaries
Channel Stability Rating System

Reach: Bois D' Arc

Rapid Assessment Stream Stability Rating

Excellent
 Good
 Fair
 Poor

Field Data Point	Station	
	To	From
BD03	75775	

Extrapolated Stations		Reasoning
To	From	
69635	76973	Identical aerial, one landowner, similar topography
65738	69171	Identical aerial, straightened, same channel dimensions

Classification Basis Evaluation Category	Excellent (9 - 10)		Good (6 - 8)		Fair (3 - 5)		Poor (0 - 2)	
	Little to no evidence of bank sloughing, slumping, or failure. (< 10%)	Banks comprised of highly resistant tree/plant/soil material.	Infrequent evidence of bank sloughing, slumping, or failure. Mostly healed over. (10-29.9%)	Banks comprised of moderately resistant tree/plant/soil material	Recent evidence of bank sloughing, slumping, or failure. High potential during flood events. (30-50%)	Banks comprised of highly erodible tree/plant/soil material and material is severely compromised.	High evidence of bank sloughing, slumping, or failure. (>50%)	
Bank Root Zone								
Vegetative Bank Cover	Abundant cover (>70%)		Moderate cover (40-69.9%)					
Bank Angle	3H:1V or flatter		2H:1V - 3H:1V					
Sediment Transport	Point bars small and stable, well vegetated and/or armored with little or no fresh sand.		Mix of point bars and few side bars.					
Channel Alteration	No manmade channel alteration.		Infrequent amount of manmade channel alteration.					
Total			0				6	
								8
								4

Description: Good stream cover, good habitat potential, steep but short banks with limited cover. Tree debris and mid-channel vegetated bars formed some undercut banks with exposed roots. Straightened reach. Deep pools, overhanging vegetation, emergent/submergent vegetation and logs/brush present.

Score	Rapid Assessment Stream Stability Rating
51 - 60	Excellent Condition
37 - 50	Good Condition
20 - 36	Fair Condition
< 20	Poor Condition

Total Score 18



Bois d'Arc Creek and its Tributaries
Channel Stability Rating System

Reach: Bois d'Arc

Rapid Assessment Stream Stability Rating

Excellent
 Good
 Fair
 Poor

Field Data Point	To	Station	From	Reasoning
BD02	78742		82975	Same aerial representation, same stream S, W & D

Extrapolated Stations				
To	From	Reasoning		
76973	82975	Same aerial representation, same stream S, W & D		

Classification Basis					
Evaluation Category	Excellent (9 - 10)	Good (6 - 8)	Fair (3 - 5)	Poor (0 - 2)	
Evidence of Bank Erosion	Little to no evidence of bank sloughing, slumping, or failure. (< 10%)	Infrequent evidence of bank sloughing, slumping, or failure. Mostly healed over. (10-29.9%)	Recent evidence of bank sloughing, slumping, or failure. High potential during flood events. (30-50%)	High evidence of bank sloughing, slumping, or failure. (>50%)	1
Bank Root Zone	Banks comprised of highly resistant tree/plant/soil material.	Banks comprised of moderately resistant tree/plant/soil material	Banks comprised of highly erodible tree/plant/soil material and material is compromised.	Banks comprised of highly erodible tree/plant/soil material and material is severely compromised.	1
Vegetative Bank Cover	Abundant cover (>70%)	Moderate cover (40-69.9%)	Infrequent cover (10-39.9%)	Little to no cover (<10%)	2
Bank Angle	3H:1V or flatter	2H:1V - 3H:1V	1H:1V - 2H:1V	1H:1V or steeper	1
Sediment Transport	Point bars small and stable, well vegetated and/or armored with little or no fresh sand.	Mix of point bars and few side bars.	Moderate amount of mid-channel bars and side bars.	Stream branching with mid-channel bars and islands or no depositional features.	0
Channel Alteration	No manmade channel alteration.	Infrequent amount of manmade channel alteration.	Moderate amount of manmade channel alteration.	Extensive amount of manmade channel alteration.	0
Total	0	0	0	0	5

Description: Right bank has thick root masses sprawling cut into the creek. Vertical banks. Left bank has some dense roots, but mostly barren slopes. No grass or shrub coverage besides tree roots. Good habitat potential and stream cover. Undercut banks. Deep pools, overhanging vegetation and logs/brush present.

Score	Rapid Assessment Stream Stability Rating
51 - 60	Excellent Condition
37 - 50	Good Condition
20 - 36	Fair Condition
< 20	Poor Condition

Total Score 5



Bois d'Arc Creek and its Tributaries
Channel Stability Rating System

Reach: Bois D' Arc

Rapid Assessment Stream Stability Rating

Excellent
 Good
 Fair
 Poor

Field Data Point	To	Station	From
BD01	83137		

Extrapolated Stations		
To	From	Reasoning
82975	END	Similar W, D & S; thick vegetation by aerial

Classification Basis Evaluation Category	Excellent (9 - 10)		Good (6 - 8)		Fair (3 - 5)		Poor (0 - 2)	
	9	10	6	7	3	4	0	1
Evidence of Bank Erosion	Little to no evidence of bank sloughing, slumping, or failure. (< 10%)	Little to no evidence of bank sloughing, slumping, or failure. (< 10%)	Infrequent evidence of bank sloughing, slumping, or failure. Mostly healed over. (10-29.9%)	Infrequent evidence of bank sloughing, slumping, or failure. (10-29.9%)	Recent evidence of bank sloughing, slumping, or failure. High potential during flood events. (30-50%)	Recent evidence of bank sloughing, slumping, or failure. High potential during flood events. (30-50%)	High evidence of bank sloughing, slumping, or failure. (>50%)	High evidence of bank sloughing, slumping, or failure. (>50%)
Bank Root Zone	Banks comprised of highly resistant tree/plant/soil material.	Banks comprised of highly resistant tree/plant/soil material.	Banks comprised of moderately resistant tree/plant/soil material	Banks comprised of moderately resistant tree/plant/soil material	Banks comprised of highly erodible tree/plant/soil material and material is severely compromised.	Banks comprised of highly erodible tree/plant/soil material and material is severely compromised.	Banks comprised of highly erodible tree/plant/soil material and material is severely compromised.	Banks comprised of highly erodible tree/plant/soil material and material is severely compromised.
Vegetative Bank Cover	Abundant cover (>70%)	Abundant cover (>70%)	Moderate cover (40-69.9%)	Moderate cover (40-69.9%)	Infrequent cover (10-39.9%)	Infrequent cover (10-39.9%)	Little to no cover (<10%)	Little to no cover (<10%)
Bank Angle	3H:1V or flatter	3H:1V or flatter	2H:1V - 3H:1V	2H:1V - 3H:1V	1H:1V - 2H:1V	1H:1V - 2H:1V	1H:1V or steeper	1H:1V or steeper
Sediment Transport	Point bars small and stable, well vegetated and/or armored with little or no fresh sand.	Point bars small and stable, well vegetated and/or armored with little or no fresh sand.	Mix of point bars and few side bars.	Mix of point bars and few side bars.	Moderate amount of mid-channel bars and side bars.	Moderate amount of mid-channel bars and side bars.	Stream branching with mid-channel bars and islands or no depositional features.	Stream branching with mid-channel bars and islands or no depositional features.
Channel Alteration	No manmade channel alteration.	No manmade channel alteration.	Infrequent amount of manmade channel alteration.	Infrequent amount of manmade channel alteration.	Moderate amount of manmade channel alteration.	Moderate amount of manmade channel alteration.	Extensive amount of manmade channel alteration.	Extensive amount of manmade channel alteration.
Total			9	8	3	5	0	0

Description: Good variety of vegetation on stream banks- shrubs, trees. Not a lot of stream cover. Steep banks. Sediment deposition in mid-channel downstream of bridge. Shallows and overhanging vegetation present

Score	Rapid Assessment Stream Stability Rating
51 - 60	Excellent Condition
37 - 50	Good Condition
20 - 36	Fair Condition
< 20	Poor Condition

Total Score 34



Bois d'Arc Creek and its Tributaries
Channel Stability Rating System

Reach: Honey Grove

Rapid Assessment Stream Stability Rating

Excellent
 Good
 Fair
 Poor

Field Data Point	To	Station	From
HG07	4106		

Extrapolated Stations			
To	From	Reasoning	
2300	4106	Similar to data, steep/deep channel but appears banks better cover, no evidence of mass wasting	
4106	5500	Similar width, depth banks, aerial; no evidence of sloughing/mass wasting	

Classification Basis Evaluation Category	Excellent (9 - 10)			Good (6 - 8)			Fair (3 - 5)			Poor (0 - 2)												
	Evidence of Bank Erosion	Little to no evidence of bank sloughing, slumping, or failure. (< 10%)	Infrequent evidence of bank sloughing, slumping, or failure. Mostly healed over. (10-29.9%)	6	Recent evidence of bank sloughing, slumping, or failure. High potential during flood events. (30-50%)	High evidence of bank sloughing, slumping, or failure. (>50%)		Banks comprised of highly erodible tree/plant/soil material.	Banks comprised of moderately resistant tree/plant/soil material	4	Banks comprised of highly erodible tree/plant/soil material and material is severely compromised.		Vegetative Bank Cover	Abundant cover (>70%)	3H:1V or flatter	Point bars small and stable, well vegetated and/or armored with little or no fresh sand.	No manmade channel alteration.	0				
Bank Root Zone												Channel Alteration										
Total		0			12			11			0											

Description: Banks have coverage, but no deep root zones. A lot of deposition, with side bars going into mid channel bars. Undercut banks, shallows, overhanging vegetation and logs/brush present

Score	Rapid Assessment Stream Stability Rating
51 - 60	Excellent Condition
37 - 50	Good Condition
20 - 36	Fair Condition
< 20	Poor Condition

Total Score 23



Bois d'Arc Creek and its Tributaries
Channel Stability Rating System

Reach: Honey Grove

Rapid Assessment Stream Stability Rating

Excellent
 Good
 Fair
 Poor

Field Data Point	To	Station	From
HG06	7570		

Extrapolated Stations	To	From	Reasoning
	5500	11820	Similar top width, banks, and channel slopes; identical aerial representation

Classification Basis Evaluation Category	Excellent (9 - 10)		Good (6 - 8)		Fair (3 - 5)		Poor (0 - 2)	
	Little to no evidence of bank sloughing, slumping, or failure. (< 10%)	Banks comprised of highly resistant tree/plant/soil material.	Infrequent evidence of bank sloughing, slumping, or failure. Mostly healed over. (10-29.9%)	Banks comprised of moderately resistant tree/plant/soil material	Recent evidence of bank sloughing, slumping, or failure. High potential during flood events. (30-50%)	Banks comprised of highly erodible tree/plant/soil material and material is compromised.	Little to no cover (<10%)	High evidence of bank sloughing, slumping, or failure. (>50%)
Bank Root Zone			6	6				
Vegetative Bank Cover	Abundant cover (>70%)	Moderate cover (40-69.9%)	8	8				
Bank Angle	3H:1V or flatter	2H:1V - 3H:1V	6	6				
Sediment Transport	Point bars small and stable, well vegetated and/or armored with little or no fresh sand.	Mix of point bars and few side bars.	6	6				
Channel Alteration	No manmade channel alteration.	Infrequent amount of manmade channel alteration.						0
Total			0	26	5	5		0

Description: Building a bankful bench. Good bank cover → more rooted species. Milky water due to suspended solids. Undercut banks, shallows, deep pools, overhanging vegetation and logs/brush present.

Score	Rapid Assessment Stream Stability Rating
51 - 60	Excellent Condition
37 - 50	Good Condition
20 - 36	Fair Condition
< 20	Poor Condition

Total Score **31**



Bois d'Arc Creek and its Tributaries
Channel Stability Rating System

Reach: Honey Grove

Rapid Assessment Stream Stability Rating

Excellent
 Good
 Fair
 Poor

Field Data Point	Station	
	To	From
HG04	18058	
HG05		

Extrapolated Stations		Reasoning
To	From	
11820	18058	Similar stream characteristics by field photo: same top width, stream slope and side slopes
18058	19500	Similar width/depth bank shape, stream slope - aerial shows minor bank sloughing 1 location
27000	29500	Similar channel pattern/shape - slightly steeper slope, good aerial similarity

Classification Basis Evaluation Category	Good (6 - 8)			Fair (3 - 5)			Poor (0 - 2)		
	Excellent (9 - 10)	Good (6 - 8)	Fair (3 - 5)	Fair (3 - 5)	Fair (3 - 5)	Poor (0 - 2)	Poor (0 - 2)	Poor (0 - 2)	
Evidence of Bank Erosion	Little to no evidence of bank sloughing, slumping, or failure. (< 10%)	Infrequent evidence of bank sloughing, slumping, or failure. Mostly healed over. (10-29.9%)	Recent evidence of bank sloughing, slumping, or failure. High potential during flood events. (30-50%)	Recent evidence of bank sloughing, slumping, or failure. High potential during flood events. (30-50%)	3	High evidence of bank sloughing, slumping, or failure. (>50%)	3	High evidence of bank sloughing, slumping, or failure. (>50%)	
Bank Root Zone	Banks comprised of highly resistant tree/plant/soil material.	Banks comprised of moderately resistant tree/plant/soil material	Banks comprised of highly erodible tree/plant/soil material and material is compromised.	Banks comprised of highly erodible tree/plant/soil material and material is severely compromised.	3	Banks comprised of highly erodible tree/plant/soil material and material is severely compromised.	3	Banks comprised of highly erodible tree/plant/soil material and material is severely compromised.	
Vegetative Bank Cover	Abundant cover (>70%)	Moderate cover (40-69.9%)	Infrequent cover (10-39.9%)	Infrequent cover (10-39.9%)	5	Little to no cover (<10%)	2	Little to no cover (<10%)	
Bank Angle	3H:1V or flatter	2H:1V - 3H:1V	1H:1V - 2H:1V	1H:1V - 2H:1V	6	Stream branching with mid-channel bars and islands or no depositional features.	5	Stream branching with mid-channel bars and islands or no depositional features.	
Sediment Transport	Point bars small and stable, well vegetated and/or armored with little or no fresh sand.	Mix of point bars and few side bars.	Moderate amount of mid-channel bars and side bars.	Moderate amount of mid-channel bars and side bars.	6	Extensive amount of manmade channel alteration.	5	Extensive amount of manmade channel alteration.	
Channel Alteration	No manmade channel alteration.	Infrequent amount of manmade channel alteration.	Moderate amount of manmade channel alteration.	Moderate amount of manmade channel alteration.	6	Extensive amount of manmade channel alteration.	5	Extensive amount of manmade channel alteration.	
Total	0	6	6	6	16	2	16	2	

Description: Milky water due to suspended solids. Skinny trees on top of banks, with some falling in creek. Undercut banks. Limited vegetation on left bank. Shallows, deep pools and overhanging vegetation also present. Class III

Score	Rapid Assessment Stream Stability Rating
51 - 60	Excellent Condition
37 - 50	Good Condition
20 - 36	Fair Condition
<20	Poor Condition

Total Score 24



Bois d'Arc Creek and its Tributaries
Channel Stability Rating System

Reach: Honey Grove

Rapid Assessment Stream Stability Rating

Excellent
 Good
 Fair
 Poor

Field Data Point	To	Station	From
HG03	23410		
HG02	24040		

Extrapolated Stations			Reasoning
To	From		
23410	25000		Sites very similar except one is in summer and the other in winter; similar top width and channel slope
19500	23410		Channel width, depth, bank similar, stream slope same - local disturbance at US end due to bridge
25000	27000		Site has similar width, depth, bank/slope - few local sloughs but good vegetation
29500	31000		Similar pattern, channel width, depth
31000	33000		More sinuous but similar slope, channel width, depth, vegetation

Classification Basis Evaluation Category	Excellent (9 - 10)		Good (6 - 8)		Fair (3 - 5)		Poor (0 - 2)	
	To	From	To	From	To	From	To	From
Evidence of Bank Erosion	10		10					
Bank Root Zone			8					
Vegetative Bank Cover	10							
Bank Angle								
Sediment Transport			6					
Channel Alteration								
Total			14		0			0

Description: In good condition, but localized destabilization due to road crossing. Section has been straightened. Built inner berm with lots of potential for habitat - good stream cover. Barren vegetation in some areas. Undercut banks, shallows, deep pools, overhanging vegetation and logs/brush present. Class V

Score	Rapid Assessment Stream Stability Rating
51 - 60	Excellent Condition
37 - 50	Good Condition
20 - 36	Fair Condition
< 20	Poor Condition

Total Score **34**



Bois d'Arc Creek and its Tributaries
Channel Stability Rating System

Reach: Honey Grove

Rapid Assessment Stream Stability Rating

Excellent
 Good
 Fair
 Poor

Field Data Point	To	Station	From
HG01	35621		

Extrapolated Stations		
To	From	Reasoning
33000	END	No aerial, but same top width and side slopes

Classification Basis Evaluation Category	Excellent (9 - 10)		Good (6 - 8)		Fair (3 - 5)		Poor (0 - 2)	
	Little to no evidence of bank sloughing, slumping, or failure. (< 10%)	Banks comprised of highly resistant tree/plant/soil material.	Infrequent evidence of bank sloughing, slumping, or failure. Mostly healed over. (10-29.9%)	Banks comprised of moderately resistant tree/plant/soil material	Recent evidence of bank sloughing, slumping, or failure. High potential during flood events. (30-50%)	Banks comprised of highly erodible tree/plant/soil material and material is severely compromised.	Little to no cover (<10%) 1H:1V or steeper	High evidence of bank sloughing, slumping, or failure. (>50%)
Bank Root Zone			8	8				
Vegetative Bank Cover	Abundant cover (>70%) 3H:1V or flatter		Moderate cover (40-69.9%) 2H:1V - 3H:1V		Infrequent cover (10-39.9%) 1H:1V - 2H:1V			
Bank Angle	Point bars small and stable, well vegetated and/or armored with little or no fresh sand.		Mix of point bars and few side bars.		Moderate amount of mid-channel bars and side bars.			
Sediment Transport	No manmade channel alteration.	9	Infrequent amount of manmade channel alteration.		Moderate amount of manmade channel alteration.			
Channel Alteration								
Total		9	22	10				0

Description: Isolated degraded area downstream of bridge to cattle crossing, but not unstable due to laid back slopes and established everywhere else. Good stream cover. Great access to floodplain for large storm events. Shallows and overhanging vegetation present. Class V



Score	Rapid Assessment Stream Stability Rating
51 - 60	Excellent Condition
37 - 50	Good Condition
20 - 36	Fair Condition
< 20	Poor Condition

Total Score **41**

Bois d'Arc Creek and its Tributaries
Channel Stability Rating System

Reach: _____ Ward _____

Rapid Assessment Stream Stability Rating

Excellent
 Good
 Fair
 Poor

Field Data Point		Station		Reasoning	
To	From	To	From	To	From
0	4000	0	4000	Similar to Bois d'Arc 17000 - effect of downturn affecting Ward	

Field Data Point		Station	
To	From	To	From
2000			

Classification Basis Evaluation Category	Excellent (9 - 10)		Good (6 - 8)		Fair (3 - 5)		Poor (0 - 2)	
	Little to no evidence of bank sloughing, slumping, or failure. (< 10%)	Banks comprised of highly resistant tree/plant/soil material.	Infrequent evidence of bank sloughing, slumping, or failure. Mostly healed over. (10-29.9%)	Banks comprised of moderately resistant tree/plant/soil material	Recent evidence of bank sloughing, slumping, or failure. High potential during flood events. (30-50%)	Banks comprised of highly erodible tree/plant/soil material and material is compromised.	High evidence of bank sloughing, slumping, or failure. (>50%)	Little to no cover (<10%) 1H:1V or steeper Stream branching with mid-channel bars and islands or no depositional features. Extensive amount of manmade channel alteration.
Evidence of Bank Erosion								1
Bank Root Zone								1
Vegetative Bank Cover	Abundant cover (>70%) 3H:1V or flatter		Moderate cover (40-69.9%) 2H:1V - 3H:1V		Infrequent cover (10-39.9%) 1H:1V - 2H:1V			3
Bank Angle	Point bars small and stable, well vegetated and/or armored with little or no fresh sand.		Mix of point bars and few side bars.		Moderate amount of mid-channel bars and side bars.			3
Sediment Transport	No manmade channel alteration.		Infrequent amount of manmade channel alteration.		Moderate amount of manmade channel alteration.			3
Channel Alteration								9
Total		0	0	0	0			4

Total Score 13

Score	Rapid Assessment Stream Stability Rating
51 - 60	Excellent Condition
37 - 50	Good Condition
20 - 36	Fair Condition
< 20	Poor Condition

Description: Midstream bars, sloughing and bank failures from aerial. Resembles Bois d'Arc at station 17000. Shallows, deep pools and overhanging vegetation present

Bois d'Arc Creek and its Tributaries
Channel Stability Rating System

Reach: _____ Ward _____

Rapid Assessment Stream Stability Rating

Excellent
 Good
 Fair
 Poor

Field Data Point	To	Station	From
W01	9735		12901
W02			
W03			

Extrapolated Stations		Reasoning
To	From	
4000	23300	Similar to data reach pattern, width, depth, slope, good riparian vegetation
23700	25500	
26800	END	

Classification Basis Evaluation Category	Excellent (9 - 10)			Good (6 - 8)			Fair (3 - 5)			Poor (0 - 2)		
	Little to no evidence of bank sloughing, slumping, or failure. (< 10%)	Banks comprised of highly resistant tree/plant/soil material.	Abundant cover (>70%) 3H:1V or flatter	Infrequent evidence of bank sloughing, slumping, or failure. Mostly healed over. (10-29.9%)	Banks comprised of moderately resistant tree/plant/soil material	Moderate cover (40-69.9%) 2H:1V - 3H:1V	Recent evidence of bank sloughing, slumping, or failure. High potential during flood events. (30-50%)	Banks comprised of highly erodible tree/plant/soil material and material is compromised.	Infrequent cover (10-39.9%) 1H:1V - 2H:1V	High evidence of bank sloughing, slumping, or failure. (>50%)	Banks comprised of highly erodible tree/plant/soil material and material is severely compromised.	Little to no cover (<10%) 1H:1V or steeper
Bank Root Zone												
Vegetative Bank Cover												
Bank Angle												
Sediment Transport												
Channel Alteration												
Total												

Description: Wide, deep channel, side bars/point bars, lower banks and channel bottom recovery - good bank vegetation. Major undercut banks and overhanging vegetation present. Class IV / V

Score	Rapid Assessment Stream Stability Rating
51 - 60	Excellent Condition
37 - 50	Good Condition
20 - 36	Fair Condition
< 20	Poor Condition

Total Score 28



Bois d'Arc Creek and its Tributaries
Channel Stability Rating System

Reach: _____ Ward _____

Rapid Assessment Stream Stability Rating

Excellent
 Good
 Fair
 Poor

Field Data Point	To	Station	From
	23500		

Extrapolated Stations		
To	From	Reasoning
23300	23700	

Classification Basis Evaluation Category	Excellent (9 - 10)		Good (6 - 8)		Fair (3 - 5)		Poor (0 - 2)	
	Little to no evidence of bank sloughing, slumping, or failure. (< 10%)	Banks comprised of highly resistant tree/plan/soil material.	Infrequent evidence of bank sloughing, slumping, or failure. Mostly healed over. (10-29.9%)	Banks comprised of moderately resistant tree/plan/soil material	Recent evidence of bank sloughing, slumping, or failure. High potential during flood events. (30-50%)	Banks comprised of highly erodible tree/plan/soil material and material is compromised.	High evidence of bank sloughing, slumping, or failure. (>50%)	0
Bank Root Zone								0
Vegetative Bank Cover	Abundant cover (>70%)		Moderate cover (40-69.9%)		Infrequent cover (10-39.9%)		Little to no cover (<10%)	0
Bank Angle	3H:1V or flatter		2H:1V - 3H:1V		1H:1V - 2H:1V		1H:1V or steeper	5
Sediment Transport	Point bars small and stable, well vegetated and/or armored with little or no fresh sand.		Mix of point bars and few side bars.		Moderate amount of mid-channel bars and side bars.		Stream branching with mid-channel bars and islands or no depositional features.	3
Channel Alteration	No manmade channel alteration.		Infrequent amount of manmade channel alteration.	8	Moderate amount of manmade channel alteration.		Extensive amount of manmade channel alteration.	
Total		0		8				8
								0

Description: Overhead electric easements - cleared of all trees and brush. Active mass wasting and widening. Undercut banks.

Score	Rapid Assessment Stream Stability Rating
51 - 60	Excellent Condition
37 - 50	Good Condition
20 - 36	Fair Condition
< 20	Poor Condition

Total Score	16
--------------------	-----------

Bois d'Arc Creek and its Tributaries
Channel Stability Rating System

Reach: _____ Ward _____

Rapid Assessment Stream Stability Rating

Excellent
 Good
 Fair
 Poor

Field Data Point	To	Station	From
	26000		

Extrapolated Stations		
To	From	Reasoning
25500	26800	

Classification Basis Evaluation Category	Excellent (9 - 10)		Good (6 - 8)		Fair (3 - 5)		Poor (0 - 2)	
	Little to no evidence of bank sloughing, slumping, or failure. (< 10%)	Banks comprised of highly resistant tree/plant/soil material.	Infrequent evidence of bank sloughing, slumping, or failure. Mostly healed over. (10-29.9%)	Banks comprised of moderately resistant tree/plant/soil material	Recent evidence of bank sloughing, slumping, or failure. High potential during flood events. (30-50%)	Banks comprised of highly erodible tree/plant/soil material and material is compromised.	Little to no cover (<10%) 1H:1V or steeper	High evidence of bank sloughing, slumping, or failure. (>50%)
Bank Root Zone								
Vegetative Bank Cover	Abundant cover (>70%) 3H:1V or flatter	Moderate cover (40-69.9%) 2H:1V - 3H:1V						
Bank Angle	Point bars small and stable, well vegetated and/or armored with little or no fresh sand.	Mix of point bars and few side bars.						
Sediment Transport	No manmade channel alteration.	Infrequent amount of manmade channel alteration.						
Channel Alteration								
Total			19					0

Description: Similar to Ward station 12000 except much steeper gradient and narrower riparian corridor. Over steepened section just below a knick point.

Score	Rapid Assessment Stream Stability Rating
51 - 60	Excellent Condition
37 - 50	Good Condition
20 - 36	Fair Condition
< 20	Poor Condition

Total Score **34**

Bois d'Arc Creek and its Tributaries
Channel Stability Rating System

Reach: Bullard

Rapid Assessment Stream Stability Rating

Excellent
 Good
 Fair
 Poor

Field Data Point	Station	
	To	From
B10	977	
B09	3362	

Extrapolated Stations		
To	From	Reasoning
0	3362	Similar top width and slopes; at station 3362, looks just like station 977 by field visit and aerial

Classification Basis Evaluation Category	Good (6 - 8)			Fair (3 - 5)			Poor (0 - 2)		
	Excellent (9 - 10)	Good (6 - 8)	Fair (3 - 5)	Fair (3 - 5)	Fair (3 - 5)	Poor (0 - 2)	Poor (0 - 2)	Poor (0 - 2)	Poor (0 - 2)
Evidence of Bank Erosion	Little to no evidence of bank sloughing, slumping, or failure. (< 10%)	Infrequent evidence of bank sloughing, slumping, or failure. Mostly healed over. (10-29.9%)	Recent evidence of bank sloughing, slumping, or failure. High potential during flood events. (30-50%)	5	High evidence of bank sloughing, slumping, or failure. (>50%)				
Bank Root Zone	Banks comprised of highly resistant tree/plant/soil material.	Banks comprised of moderately resistant tree/plant/soil material	Banks comprised of highly erodible tree/plant/soil material and material is compromised.	4	Banks comprised of highly erodible tree/plant/soil material and material is severely compromised.				
Vegetative Bank Cover	Abundant cover (>70%)	Moderate cover (40-69.9%)	Infrequent cover (10-39.9%)	5	Little to no cover (<10%)				
Bank Angle	3H:1V or flatter	2H:1V - 3H:1V	1H:1V - 2H:1V	5	1H:1V or steeper				
Sediment Transport	Point bars small and stable, well vegetated and/or armored with little or no fresh sand.	Mix of point bars and few side bars.	Moderate amount of mid-channel bars and side bars.	6	Stream branching with mid-channel bars and islands or no depositional features.				
Channel Alteration	No manmade channel alteration.	Infrequent amount of manmade channel alteration.	Moderate amount of manmade channel alteration.		Extensive amount of manmade channel alteration.				0
Total		0	6	19					0

Description: Depositional area along sides of creek. Vegetation made up of trees and grasses. Sloughing from upper banks. Forming vegetated inner berms. Steep banks outside of berms. 50% cover on banks. Undercut banks, shallows, overhanging vegetation and logs/brush present. Class III

Score	Rapid Assessment Stream Stability Rating
51 - 60	Excellent Condition
37 - 50	Good Condition
20 - 36	Fair Condition
< 20	Poor Condition

Total Score **25**



Bois d'Arc Creek and its Tributaries
Channel Stability Rating System

Reach: Bullard

Rapid Assessment Stream Stability Rating

Excellent
 Good
 Fair
 Poor

Field Data Point	Station	
	To	From
B08	7286	

Extrapolated Stations		
To	From	Reasoning
3362	8261	One landowner, minimal vegetation on floodplain by aerial, same width, depth, slope, straightened reach
20330	22943	Similar farming practices, straightened reach; similar slope, but smaller width, depth due to less drainage area

Classification Basis Evaluation Category	Excellent (9 - 10)			Good (6 - 8)			Fair (3 - 5)			Poor (0 - 2)			
	Little to no evidence of bank sloughing, slumping, or failure. (< 10%)	Banks comprised of highly resistant tree/plant/soil material.	Abundant cover (>70%) 3H:1V or flatter	Infrequent evidence of bank sloughing, slumping, or failure. Mostly healed over. (10-29.9%)	Banks comprised of moderately resistant tree/plant/soil material	Moderate cover (40-69.9%) 2H:1V - 3H:1V	Recent evidence of bank sloughing, slumping, or failure. High potential during flood events. (30-50%)	Banks comprised of highly erodible tree/plant/soil material and material is compromised.	Infrequent cover (10-39.9%) 1H:1V - 2H:1V	Little to no cover (<10%) 1H:1V or steeper	High evidence of bank sloughing, slumping, or failure. (>50%)	Banks comprised of highly erodible tree/plant/soil material and material is severely compromised.	Little to no cover (<10%) 1H:1V or steeper
Bank Root Zone													
Vegetative Bank Cover													
Bank Angle													
Sediment Transport													
Channel Alteration													
Total													

Description: Vertical left bank made up of tree roots and grasses. Laid back right slope. Deposition in creek forming vegetated inner berms. Lots of stream cover. Undermining at toe of slope. Overhanging vegetation. Developing into a good 'C' channel. Class IV

Score	Rapid Assessment Stream Stability Rating
51 - 60	Excellent Condition
37 - 50	Good Condition
20 - 36	Fair Condition
<20	Poor Condition

Total Score 19



Bois d'Arc Creek and Its Tributaries
Channel Stability Rating System

Reach: Bullard

Rapid Assessment Stream Stability Rating

Excellent
 Good
 Fair
 Poor

Field Data Point	To	Station	From
B07	10394		

Extrapolated Stations		Reasoning
To	From	
8261	14932	Similar width, depth, slope; same aerial representation

Classification Basis Evaluation Category	Excellent (9 - 10)		Good (6 - 8)		Fair (3 - 5)		Poor (0 - 2)	
	Little to no evidence of bank sloughing, slumping, or failure. (< 10%)	Infrequent evidence of bank sloughing, slumping, or failure. Mostly healed over. (10-29.9%)	Recent evidence of bank sloughing, slumping, or failure. High potential during flood events. (30-50%)	High evidence of bank sloughing, slumping, or failure. (>50%)	Little to no evidence of bank sloughing, slumping, or failure. (< 10%)	Moderate amount of mid-channel bars and side bars.	Stream branching with mid-channel bars and islands or no depositional features.	High evidence of bank sloughing, slumping, or failure. (>50%)
Bank Root Zone	Banks comprised of highly resistant tree/plant/soil material.	Banks comprised of moderately resistant tree/plant/soil material	Banks comprised of highly erodible tree/plant/soil material and material is compromised.	Banks comprised of highly erodible tree/plant/soil material and material is severely compromised.	Abundant cover (>70%)	Moderate cover (40-69.9%)	Little to no cover (<10%)	2
Vegetative Bank Cover	3H:1V or flatter	2H:1V - 3H:1V	1H:1V - 2H:1V	1H:1V or steeper	Point bars small and stable, well vegetated and/or armored with little or no fresh sand.	Mix of point bars and few side bars.	Stream branching with mid-channel bars and islands or no depositional features.	1
Bank Angle	Point bars small and stable, well vegetated and/or armored with little or no fresh sand.	Infrequent amount of manmade channel alteration.	Moderate amount of manmade channel alteration.	Extensive amount of manmade channel alteration.	No manmade channel alteration.	Moderate amount of manmade channel alteration.	Extensive amount of manmade channel alteration.	2
Sediment Transport	Point bars small and stable, well vegetated and/or armored with little or no fresh sand.	Infrequent amount of manmade channel alteration.	Moderate amount of manmade channel alteration.	Extensive amount of manmade channel alteration.	0	0	6	5
Channel Alteration	No manmade channel alteration.	Infrequent amount of manmade channel alteration.	Moderate amount of manmade channel alteration.	Extensive amount of manmade channel alteration.	0	0	6	5
Total					0	0	6	5

Description: Evident from aerial that outside banks at meanders are widening and have no vegetation to stabilize. Vertical banks on both sides with inner berm forming due to mass wasting from upper banks. Little to no vegetation on slopes. Landowners farming right up to left stream bank. Deeply incised channel. Undercut banks, shallows and overhanging vegetation present. Class III

Score	Rapid Assessment Stream Stability Rating
51 - 60	Excellent Condition
37 - 50	Good Condition
20 - 36	Fair Condition
< 20	Poor Condition

Total Score **11**



Bois d'Arc Creek and its Tributaries
Channel Stability Rating System

Reach: Bullard

Rapid Assessment Stream Stability Rating

Excellent
 Good
 Fair
 Poor

Field Data Point	Station	
	To	From
B06	15911	

Extrapolated Stations		
To	From	Reasoning
14932	16060	Field inspection; creek confined by road on left and farmed right up to bank on left

Classification Basis Evaluation Category	Good (6 - 8)			Fair (3 - 5)			Poor (0 - 2)		
	Excellent (9 - 10)	Good (6 - 8)	Fair (3 - 5)	Fair (3 - 5)	Poor (0 - 2)	Poor (0 - 2)	Poor (0 - 2)	Poor (0 - 2)	Poor (0 - 2)
Evidence of Bank Erosion	Little to no evidence of bank sloughing, slumping, or failure. (< 10%)	Infrequent evidence of bank sloughing, slumping, or failure. Mostly healed over. (10-29.9%)	Recent evidence of bank sloughing, slumping, or failure. High potential during flood events. (30-50%)	Recent evidence of bank sloughing, slumping, or failure. High potential during flood events. (30-50%)	High evidence of bank sloughing, slumping, or failure. (>50%)				1
Bank Root Zone	Banks comprised of highly resistant tree/plant/soil material.	Banks comprised of moderately resistant tree/plant/soil material	Banks comprised of highly erodible tree/plant/soil material and material is compromised.	Banks comprised of highly erodible tree/plant/soil material and material is severely compromised.					0
Vegetative Bank Cover	Abundant cover (>70%)	Moderate cover (40-69.9%)	Infrequent cover (10-39.9%)	Infrequent cover (10-39.9%)	Little to no cover (<10%)				2
Bank Angle	3H:1V or flatter	2H:1V - 3H:1V	1H:1V - 2H:1V	1H:1V - 2H:1V	Stream branching with mid-channel bars and islands or no depositional features.				
Sediment Transport	Point bars small and stable, well vegetated and/or armored with little or no fresh sand.	Mix of point bars and few side bars.	Moderate amount of mid-channel bars and side bars.	Moderate amount of mid-channel bars and side bars.	Stream branching with mid-channel bars and islands or no depositional features.				
Channel Alteration	No manmade channel alteration.	Infrequent amount of manmade channel alteration.	Moderate amount of manmade channel alteration.	Moderate amount of manmade channel alteration.	Extensive amount of manmade channel alteration.				0
Total		6	6	3					3

Description: Hard armored with concrete on right bank and confined by road. Vegetated up to left bank with only grass as vegetation. Degradation due to road crossing. Class I

Score	Rapid Assessment Stream Stability Rating
51 - 60	Excellent Condition
37 - 50	Good Condition
20 - 36	Fair Condition
<20	Poor Condition

Total Score	12
-------------	----



Bois d'Arc Creek and its Tributaries
Channel Stability Rating System

Reach: Bullard

Rapid Assessment Stream Stability Rating

Excellent Good Fair Poor

Field Data Point	Station	
	To	From
B04	16993	
B05	16118	

Extrapolated Stations		
To	From	Reasoning
16060	16200	Similar topography and identical aerial imagery
16200	16993	Similar topography and identical aerial imagery

Classification Basis Evaluation Category	Excellent (9 - 10)			Good (6 - 8)			Fair (3 - 5)			Poor (0 - 2)		
	Little to no evidence of bank sloughing, slumping, or failure. (< 10%)	Banks comprised of highly resistant tree/plant/soil material.	Abundant cover (>70%) 3H:1V or flatter Point bars small and stable, well vegetated and/or armored with little or no fresh sand. No manmade channel alteration.	Little to no evidence of bank sloughing, slumping, or failure. Mostly healed over. (10-29.9%)	Banks comprised of moderately resistant tree/plant/soil material	Moderate cover (40-69.9%) 2H:1V - 3H:1V Mix of point bars and few side bars.	Infrequent evidence of bank sloughing, slumping, or failure. (30-50%)	Banks comprised of highly erodible tree/plant/soil material and material is compromised.	Infrequent cover (10-39.9%) 1H:1V - 2H:1V Moderate amount of mid-channel bars and side bars.	Recent evidence of bank sloughing, slumping, or failure. High potential during flood events. (30-50%)	Banks comprised of highly erodible tree/plant/soil material and material is severely compromised. Little to no cover (<10%) 1H:1V or steeper Stream branching with mid-channel bars and islands or no depositional features. Extensive amount of manmade channel alteration.	High evidence of bank sloughing, slumping, or failure. (>50%)
Evidence of Bank Erosion												2
Bank Root Zone												3
Vegetative Bank Cover												5
Bank Angle												2
Sediment Transport												3
Channel Alteration												0
Total												11
												4

Description: Sleep banks, loose sand, downed trees, little vegetation on banks. Undercut banks, deep pools, overhanging vegetation and logs/brush present. Class III / IV

Score	Rapid Assessment Stream Stability Rating
51 - 60	Excellent Condition
37 - 50	Good Condition
20 - 36	Fair Condition
< 20	Poor Condition

Total Score **15**



Bois d'Arc Creek and its Tributaries
Channel Stability Rating System

Reach: Bullard

Rapid Assessment Stream Stability Rating

Excellent
 Good
 Fair
 Poor

Field Data Point	To	Station	From
B03	18188		

Extrapolated Stations		Reasoning
To	From	Similar site characteristics; straightened section of creek
16993	18188	

Classification Basis Evaluation Category	Excellent (9 - 10)		Good (6 - 8)		Fair (3 - 5)		Poor (0 - 2)	
	Little to no evidence of bank sloughing, slumping, or failure. (< 10%)	Banks comprised of highly resistant tree/plant/soil material.	Infrequent evidence of bank sloughing, slumping, or failure. Mostly healed over. (10-29.9%)	Banks comprised of moderately resistant tree/plant/soil material	Recent evidence of bank sloughing, slumping, or failure. High potential during flood events. (30-50%)	Banks comprised of highly erodible tree/plant/soil material and material is severely compromised.	Little to no cover (<10%) 1H:1V or steeper	High evidence of bank sloughing, slumping, or failure. (>50%)
Bank Root Zone								2
Vegetative Bank Cover	Abundant cover (>70%) 3H:1V or flatter		Moderate cover (40-69.9%) 2H:1V - 3H:1V					
Bank Angle	Point bars small and stable, well vegetated and/or armored with little or no fresh sand.		Mix of point bars and few side bars.					1
Sediment Transport	No manmade channel alteration.		Infrequent amount of manmade channel alteration.					
Channel Alteration								0
Total		0		0			7	5

Description: Really steep banks, exposed roots, lots of debris, little vegetation on banks. Undercut banks, overhanging vegetation and logs/brush present. Class IV

Score	Rapid Assessment Stream Stability Rating
51 - 60	Excellent Condition
37 - 50	Good Condition
20 - 36	Fair Condition
< 20	Poor Condition

Total Score **12**



Bois d'Arc Creek and Its Tributaries
Channel Stability Rating System

Reach: Bullard

Rapid Assessment Stream Stability Rating

Excellent
 Good
 Fair
 Poor

Field Data Point	Station	
	To	From
B02	18821	

Extrapolated Stations		
To	From	Reasoning
18188	19346	Same landowner, aerial matches; similar topography with matching side slopes, top width, and slope
19346	20330	Same channel properties (width, depth, slope), but less vegetation according to aerial; same channel pattern
24000	END	Same channel properties and pattern; limited vegetation on right overbank

Classification Basis Evaluation Category	Excellent (9 - 10)		Good (6 - 8)		Fair (3 - 5)		Poor (0 - 2)	
	Little to no evidence of bank sloughing, slumping, or failure. (< 10%)	Banks comprised of highly resistant tree/plant/soil material.	Infrequent evidence of bank sloughing, slumping, or failure. Mostly healed over. (10-29.9%)	Banks comprised of moderately resistant tree/plant/soil material	Recent evidence of bank sloughing, slumping, or failure. High potential during flood events. (30-50%)	Banks comprised of highly erodible tree/plant/soil material and material is compromised.	High evidence of bank sloughing, slumping, or failure. (>50%)	
Bank Root Zone								2
Vegetative Bank Cover	Abundant cover (>70%)		Moderate cover (40-69.9%)					2
Bank Angle	3H:1V or flatter		2H:1V - 3H:1V					1
Sediment Transport	Point bars small and stable, well vegetated and/or armored with little or no fresh sand.	6	Mix of point bars and few side bars.					
Channel Alteration	No manmade channel alteration.		Infrequent amount of manmade channel alteration.					0
Total		0		6			0	7

Description: Channelized section with no bars forming or potential for instream habitat. Vertical banks with decent root zone. Vegetation sparse. Undercut banks and overhanging vegetation present. Class II

Score	Rapid Assessment Stream Stability Rating
51 - 60	Excellent Condition
37 - 50	Good Condition
20 - 36	Fair Condition
< 20	Poor Condition

Total Score 13



Bois d'Arc Creek and its Tributaries
Channel Stability Rating System

Reach: Bullard

Rapid Assessment Stream Stability Rating

Excellent
 Good
 Fair
 Poor

Field Data Point	Station	
	To	From
B01	22943	23700

Extrapolated Stations		Reasoning
To	From	
23700	24000	Similar aerial representation by straightening and vegetation; same channel properties

Classification Basis Evaluation Category	Excellent (9 - 10)			Good (6 - 8)			Fair (3 - 5)			Poor (0 - 2)						
	Little to no evidence of bank sloughing, slumping, or failure. (< 10%)	Banks comprised of highly resistant tree/plant/soil material.	Abundant cover (>70%) 3H:1V or flatter	Infrequent evidence of bank sloughing, slumping, or failure. Mostly healed over. (10-29.9%)	Banks comprised of moderately resistant tree/plant/soil material	Moderate cover (40-69.9%) 2H:1V - 3H:1V	Recent evidence of bank sloughing, slumping, or failure. High potential during flood events. (30-50%)	Banks comprised of highly erodible tree/plant/soil material and material is compromised.	Infrequent cover (10-39.9%) 1H:1V - 2H:1V	Moderate amount of mid-channel bars and side bars.	Stream branching with mid-channel bars and islands or no depositional features.	High evidence of bank sloughing, slumping, or failure. (>50%)	Banks comprised of highly erodible tree/plant/soil material and material is severely compromised.	Little to no cover (<10%) 1H:1V or steeper	Stream branching with mid-channel bars and islands or no depositional features.	Extensive amount of manmade channel alteration.
Bank Root Zone						8										
Vegetative Bank Cover																
Bank Angle																
Sediment Transport																
Channel Alteration																0
Total						16								8		0

Description: Bridge crossing @ US 82. Good overhanging vegetation along banks and overbanks. Good stream cover. Straightened for (2) bridge crossings. Minor sedimentation downstream of crossings. Class V / VI

Score	Rapid Assessment Stream Stability Rating
51 - 60	Excellent Condition
37 - 50	Good Condition
20 - 36	Fair Condition
< 20	Poor Condition

Total Score 33



Bois d'Arc Creek and its Tributaries
Channel Stability Rating System

Reach: Sandy

Rapid Assessment Stream Stability Rating

Excellent
 Good
 Fair
 Poor

Field Data Point	To	Station	From
S05	1825		

Extrapolated Stations		Reasoning
To	From	
1600	2200	Short reach upstream and downstream of the road crossing appear stable; flat slopes; good vegetation

Classification Basis Evaluation Category	Excellent (9 - 10)		Good (6 - 8)		Fair (3 - 5)		Poor (0 - 2)	
	Little to no evidence of bank sloughing, slumping, or failure. (< 10%)	Banks comprised of highly resistant tree/plant/soil material.	Infrequent evidence of bank sloughing, slumping, or failure. Mostly healed over. (10-29.9%)	Banks comprised of moderately resistant tree/plant/soil material	Recent evidence of bank sloughing, slumping, or failure. High potential during flood events. (30-50%)	Banks comprised of highly erodible tree/plant/soil material and material is severely compromised.	High evidence of bank sloughing, slumping, or failure. (>50%)	
Bank Root Zone	Abundant cover (>70%)	Point bars small and stable, well vegetated and/or armored with little or no fresh sand.	Moderate cover (40-69.9%)	Infrequent cover (10-39.9%)	Little to no cover (<10%)			
Vegetative Bank Cover	3H:1V or flatter	Mix of point bars and few side bars.	2H:1V - 3H:1V	1H:1V - 2H:1V	Stream branching with mid-channel bars and islands or no depositional features.			
Bank Angle	Point bars small and stable, well vegetated and/or armored with little or no fresh sand.	Infrequent amount of manmade channel alteration.			Extensive amount of manmade channel alteration.			
Sediment Transport	No manmade channel alteration.							
Channel Alteration								
Total	0	0	0	0	16			2

Description: Very sandy → deposition in creek, lots of instream cover. Bank vegetation includes grass and small woody material. Bank angle is flatter than incised reaches. Road is acting as a hard point. Shallows, overhanging vegetation, emergent/submergent vegetation and logs/bush present.

Score	Rapid Assessment Stream Stability Rating
51 - 60	Excellent Condition
37 - 50	Good Condition
20 - 36	Fair Condition
< 20	Poor Condition

Total Score **18**



Bois d'Arc Creek and its Tributaries
Channel Stability Rating System

Reach: Sandy

Rapid Assessment Stream Stability Rating

Excellent
 Good
 Fair
 Poor

Field Data Point	To	Station	From
S01	3291		4615
S02			
S03			
S04			

Extrapolated Stations		To	From	Reasoning
		0	1600	Similar to data reach W, D and bank angle; channel downcut below rooting zone, little in channel vegetation
		2200	9700	Similar to data reach W, D and bank angle; channel downcut below rooting zone, little in channel vegetation
		10800	11400	Similar to data reach W, D and bank angle; channel downcut below rooting zone, little in channel vegetation
		12700	END	Similar to data reach W, D and bank angle; channel downcut below rooting zone, little in channel vegetation

Classification Basis Evaluation Category	Excellent (9 - 10)		Good (6 - 8)		Fair (3 - 5)		Poor (0 - 2)	
	Little to no evidence of bank sloughing, slumping, or failure. (< 10%)	Banks comprised of highly resistant tree/plant/soil material.	Infrequent evidence of bank sloughing, slumping, or failure. Mostly healed over. (10-29.9%)	Banks comprised of moderately resistant tree/plant/soil material	Recent evidence of bank sloughing, slumping, or failure. High potential during flood events. (30-50%)	Banks comprised of highly erodible tree/plant/soil material and material is severely compromised.	Little to no cover (<10%) 1H:1V or steeper	High evidence of bank sloughing, slumping, or failure. (>50%)
Bank Root Zone								
Vegetative Bank Cover	Abundant cover (>70%) 3H:1V or flatter		Moderate cover (40-69.9%) 2H:1V - 3H:1V					
Bank Angle	Point bars small and stable, well vegetated and/or armored with little or no fresh sand.		Mix of point bars and few side bars.					
Sediment Transport	No manmade channel alteration.		Infrequent amount of manmade channel alteration.					
Channel Alteration								
Total								

Description: Very sandy → deposition in creek, lots of instream cover but no bank covers except tree roots. Undercut banks, overhanging vegetation and logs/brush present.

Score	Rapid Assessment Stream Stability Rating
51 - 60	Excellent Condition
37 - 50	Good Condition
20 - 36	Fair Condition
< 20	Poor Condition

Total Score 13



Bois d'Arc Creek and its Tributaries
Channel Stability Rating System

Reach: Sandy

Rapid Assessment Stream Stability Rating

Excellent
 Good
 Fair
 Poor

Field Data Point	To	From
	9700	

Extrapolated Stations		
To	From	Reasoning
9700	10800	Short reach upstream and downstream of the road crossing appear stable; flat slopes; good vegetation
11400	12700	

Classification Basis				
Evaluation Category	Excellent (9 - 10)	Good (6 - 8)	Fair (3 - 5)	Poor (0 - 2)
Evidence of Bank Erosion	Little to no evidence of bank sloughing, slumping, or failure. (< 10%)	Infrequent evidence of bank sloughing, slumping, or failure. Mostly healed over. (10-29.9%)	Recent evidence of bank sloughing, slumping, or failure. High potential during flood events. (30-50%)	High evidence of bank sloughing, slumping, or failure. (>50%)
Bank Root Zone	Banks comprised of highly resistant tree/plant/soil material.	Banks comprised of moderately resistant tree/plant/soil material	Banks comprised of highly erodible tree/plant/soil material and material is compromised.	Banks comprised of highly erodible tree/plant/soil material and material is severely compromised.
Vegetative Bank Cover	Abundant cover (>70%)	Moderate cover (40-69.9%)	Infrequent cover (10-39.9%)	Little to no cover (<10%)
Bank Angle	3H:1V or flatter	2H:1V - 3H:1V	1H:1V - 2H:1V	1H:1V or steeper
Sediment Transport	Point bars small and stable, well vegetated and/or armored with little or no fresh sand.	Mix of point bars and few side bars.	Moderate amount of mid-channel bars and side bars.	Stream branching with mid-channel bars and islands or no depositional features.
Channel Alteration	No manmade channel alteration.	Infrequent amount of manmade channel alteration.	Moderate amount of manmade channel alteration.	Extensive amount of manmade channel alteration.
Total	0	6	18	0

Description: Very sandy → deposition in creek, lots of instream cover. Bank angle is flatter than incised reaches. Riparian vegetation and land use changes along this reach occurred sooner than along remainder of the reach. Overhanging vegetation

Score	Rapid Assessment Stream Stability Rating
51 - 60	Excellent Condition
37 - 50	Good Condition
20 - 36	Fair Condition
< 20	Poor Condition

Total Score 24

Appendix B
References

References

- Allen, P.M., and Aquafor Beech Limited 2006. Review of Draft Report Entitled: Geomorphic and Sedimentation Evaluation of North Sulfur River and Tributaries for the Ralph Hall Lake Dam Project.
- Bureau of Economic Geology, 1967. Geologic Atlas of Texas – Sherman Sheet.
- Gellis, A.C., Hereford, R., Schumm, S.A., and Hayes, B.R., 1995. Channel evolution and hydrologic variations on Colorado River Basin: Factors influencing sediment and salt loads. *Journal of Hydrology* 124, pp. 317-344.
- Griffith, G.E., Bryce, S.A., Omernik, J.M., Comstock, J.A., Rogers, A.C., Harrison, B., Hatch, S.L., Bezanson, D., 2004, *Ecoregions of Texas*.
- Harvey, M.D., and C.C. Watson. 1986. Fluvial processes and morphological thresholds in incised channel restoration. *Water Resources Bulletin*, v. 22, no. 3, pp. 359-368. Reprinted in W.L. Jackson (ed), *Engineering Considerations in Small Stream Management*, AWRA Monograph Series No. 5.
- Ireland, H.A., C.F.S. Sharpe, and D.H. Eargle. 1939. Principles of gully erosion in the Piedmont of South Carolina. U.S. Department of Agriculture Technical Bulletin 633.
- Kline, et al., 2007. Vermont Stream Geomorphic Assessment Phase 2 Handbook Rapid Stream Assessment Field Protocols.
- Metropolitan Council of Governments 1992. Montgomery County Rapid Stream Assessment Technique (RSAT).
- Mussetter Engineering, Inc. 2006. Geomorphic and Sedimentation Evaluation of North Sulphur River and Tributaries for the Lake Ralph Hall Project.
- Rosgen, Dave 2006. Watershed Assessment of River Stability and Sediment Supply. Wildland Hydrology, Fort Collins, Colorado. Misc. pages.
- Schumm, S.A., M.D. Harvey, and C. C. Watson (eds). 1984. *Incised Channels: Morphology, Dynamics and Control*. Water Resources Publications, Littleton, Colorado, 200 pp. UT Geology Library GB 565 M7 S38 1984
- Schumm, S.A., 1999. Causes and Controls of Channel Incision. In Darby, S.E. and Simons, A (eds). *Incised River Channels: Processes, Forms, Engineering, and Management*, John Wiley & Sons, New York, Chapter 2.
- Simon, A. and C.R. Hupp. 1986. Channel evolution in modified Tennessee channels. In *Proceedings of the Fourth Federal Interagency Sedimentation Conference*, v. 2, U.S. Government Printing Office, Washington, D.C. pp. 5-71 – 5-82. **HC PDF**
- Simon, A. 1989. A model of channel response in disturbed alluvial channels. *Earth Surface Processes and Landforms*, 14, 1, pp. 11-26. Geology Library

Texas Department of Water Resources, 1982. Occurrence, Availability, and Chemical Quality of Groundwater in the Cretaceous Aquifers of North-Central Texas.

Texas Commission on Environmental Quality, Texas Parks and Wildlife Department, and Texas Water Development Board. May 2008. Texas Instream Flow Studies: Technical Overview. Texas Water Development Board Report 369.

United States Department of Agriculture, 2001. Soil Survey of Fannin County, Texas.

Appendix C
Glossary of Terms

Glossary of Terms

Adapted from:

ERDC TN-EMRRP-SR-01 1

Glossary of Stream Restoration Terms

by *Craig Fischenich*.. February 2000

USACE Research and Development Center, Environmental Laboratory,
3909 Halls Ferry Rd., Vicksburg, MS 39180

Aggradation, aggrade - A progressive buildup or raising of the channel bed and floodplain due to sediment deposition. The geologic process by which streambeds are raised in elevation and floodplains are formed. Aggradation indicates that stream discharge and/or bed-load characteristics are changing. Opposite of degradation.

Alluvial - Deposited by running water.

Alluvium - A general term for detrital deposits made by streams on riverbeds, floodplains, and alluvial fans; esp. a deposit of silt or silty clay laid down during time of flood. The term applies to stream deposits of recent time. It does not include subaqueous sediments of seas or lakes.

Anthropogenic – Of, relating to, or resulting from the influence of human beings on nature.

Armoring - A natural process where an erosion-resistant layer of relatively large particles is established on the surface of the streambed through removal of finer particles by stream flow. A properly armored streambed generally resists movement of bed material at discharges up to approximately 3/4 bank-full depth.

Bank stability - The ability of a streambank to counteract erosion or gravity forces.

Bar - An accumulation of alluvium (usually gravel or sand) caused by a decrease in sediment transport capacity on the inside of meander bends or in the center of an over-widened channel.

Biodiversity – Biological diversity in an environment as indicated by numbers of different species of plants and animals.

Canopy - A layer of foliage in a forest stand. This most often refers to the uppermost layer of foliage, but it can be used to describe lower layers in a multistoried stand. Leaves, branches and vegetation that are above ground and/or water that provides shade and cover for fish and wildlife.

Channel - An area that contains continuously or periodically flowing water that is confined by banks and a streambed.

Channelization - The process of changing (usually straightening) the natural path of a waterway.

Confluence – Junction of two or more streams.

Cover – Any structure that provides refuge for fish, reptiles or amphibians. These animals seek cover to hide from predators, to avoid warm water temperatures, and to rest, by avoiding higher velocity water. These animals come in all sizes, so even cobbles on the stream bottom that are not sedimented in with fine sands and silt can serve as cover for small fish and salamanders. Larger fish and reptiles often use large boulders, undercut banks, submerged logs, and snags for cover.

Cretaceous – Of, relating to, or being the last period of the Mesozoic Era categorized by continued dominance of reptiles, emergent dominance of angiosperms, diversification of mammals, and the extinction of many types of organisms at the close of the period;

Degradation - A progressive lowering of the channel bed due to scour. Degradation is an indicator that the stream's discharge and/or sediment load is changing. The opposite of aggradation.

Downcut – Process by which a stream adjusts vertically by scouring the channel profile.

Erosion factor, K – Susceptibility of a soil to sheet and rill erosion by water. The estimates are based on percentage of silt, sand, and organic matter (up to 4 percent) and on soil structure and permeability. Values of K range from 0.02 – 0.64; the higher the value, the more susceptible the soil is to sheet and rill erosion by water.

Ferruginous – (1) Of, relating to, or containing iron; (2) Resembling iron rust in color.

Floodplain - Land built of sediment that is regularly covered with water as a result of the flooding of a nearby stream.

Floodplain (100-year) - The area adjacent to a stream that has a one percent probability of flooding in any given year.

Fluvial – (1) Of, relating to, or living in a stream or river; (2) Produced by the action of a stream.

Geomorphology - A branch of both physiography and geology that deals with the form of the earth, the general configuration of its surface, and the changes that take place due to erosion of the primary elements and the buildup of erosional debris.

Glauconite – A mineral consisting of a dull green earthy iron potassium silicate occurring in greensand.

Headcut – (1) Exposed subsoil in section, forming small tunnels that may attain lengths of many feet. (2) Collapse of tunnel roofs initiates lateral gullying and lengthens existing cuts headward. (3) Commonly associated with piping, because headcuts frequently expose the subsoil. (4) An abrupt step in the channel profile, some several feet high.

Incised river - A river that erodes its channel by the process of degradation to a lower base level than existed previously or is consistent with the current hydrology.

Incision ratio - The low bank height divided by the bankfull maximum depth.

Inner berm – The mean high water mark; scour line or small bench halfway between the low flow water surface and bankfull stage

Instream cover - The layers of vegetation, like trees, shrubs, and overhanging vegetation, that are in the stream or immediately adjacent to the wetted channel.

Instream flows - (1) Portion of a flood flow that is contained by the channel. (2) A minimum flow requirement to maintain ecological health in a stream.

Inundation – To cover with a flood.

Lithology – (1) The study of rocks; (2) The character of a rock formation; a rock formation having a particular set of characteristics.

Marl – A loose or crumbling deposit (as of sand, silt, or clay) that contains a substantial amount of calcium carbonate.

Mass wasting - Bulk movements of soil and rock debris down slopes in response to the pull of gravity, or the rapid or gradual sinking of the Earth's ground surface in a predominantly vertical direction.

Meander - The winding of a stream channel, usually in an erodible alluvial valley. A series of sine-generated curves characterized by curved flow and alternating banks and shoals.

Mid-channel Bars – bars located in the channel away from the banks, generally found in areas where the channel runs straight. Mid-channel bars caused by recent channel instability are unvegetated.

Point bar - The convex side of a meander bend that is built up due to sediment deposition.

Pool - A reach of stream that is characterized by deep, low-velocity water and a smooth surface.

Reach - A section of stream having relatively uniform physical attributes, such as valley confinement, valley slope, sinuosity, dominant bed material, and bed form, as determined in the Phase 1 assessment.

Riffle - A reach of stream that is characterized by shallow, fast-moving water broken by the presence of rocks and boulders.

Riparian area - An area of land and vegetation adjacent to a stream that has a direct effect on the stream. This includes woodlands, vegetation, and floodplains.

Riparian buffer - the width of naturally vegetated land adjacent to the stream between the top of the bank (or top of slope, depending on site characteristics) and the edge of other land uses. A buffer is largely undisturbed and consists of the trees, shrubs, groundcover plants, duff layer, and naturally uneven ground surface. The buffer serves to protect the water body from the impacts of adjacent land uses.

Riparian corridor - lands defined by the lateral extent of a stream's meanders necessary to maintain a stable stream dimension, pattern, profile, and sediment regime. For instance, in stable pool-riffle streams, riparian corridors may be as wide as 10-12 times the channel's bankfull width. In addition the riparian corridor typically corresponds to the land area surrounding and including the stream that supports (or could support if unimpacted) a distinct

ecosystem, generally with abundant and diverse plant and animal communities (as compared with upland communities).

Riparian habitat - The aquatic and terrestrial habitat adjacent to streams, lakes, estuaries, or other waterways.

Riparian - Located on the banks of a stream or other body of water.

Riparian vegetation - The plants that grow adjacent to a wetland area such as a river, stream, reservoir, pond, spring, marsh, bog, meadow, etc., and that rely upon the hydrology of the associated water body.

River channels - Large natural or artificial open streams that continuously or periodically contain moving water, or which form a connection between two bodies of water.

River reach - Any defined length of a river.

Riverine - Relating to, formed by, or resembling a river including tributaries, streams, brooks, etc.

Riverine habitat - The aquatic habitat within streams and rivers.

Sand - Small substrate particles, generally from 0.06 to 2 mm in diameter. Sand is larger than silt and smaller than gravel.

Scour - The erosive action of running water in streams, which excavates and carries away material from the bed and banks. Scour may occur in both earth and solid rock material and can be classed as general, contraction, or local scour.

Sediment - Soil or mineral material transported by water or wind and deposited in streams or other bodies of water.

Sedimentation - (1) The combined processes of soil erosion, entrainment, transport, deposition, and consolidation. (2) Deposition of sediment.

Sinuosity - The ratio of channel length to direct down-valley distance. Also may be expressed as the ratio of down-valley slope to channel slope.

Sinuuous – Of a serpentine or wavy planform.

Slope - The ratio of the change in elevation over distance.

Slope stability - The resistance of a natural or artificial slope or other inclined surface to failure by mass movement.

Stable channel - A stream channel with the right balance of slope, planform, and cross section to transport both the water and sediment load without net long-term bed or bank sediment deposition or erosion throughout the stream segment.

Straightening - the removal of meander bends, often done in towns and along roadways, railroads, and agricultural fields.

Stream - A general term for a body of water flowing by gravity; natural watercourse containing water at least part of the year. In hydrology, the term is generally applied to the water flowing in a natural narrow channel as distinct from a canal.

Stream banks - features that define the channel sides and contain stream flow within the channel; this is the portion of the channel bank that is between the toe of the bank slope and the bankfull elevation. The banks are distinct from the streambed, which is normally wetted and provides a substrate that supports aquatic organisms. The top of bank is the point where an abrupt change in slope is evident, and where the stream is generally able to overflow the banks and enter the adjacent floodplain during flows at or exceeding the average annual high water.

Stream channel - A long narrow depression shaped by the concentrated flow of a stream and covered continuously or periodically by water.

Stream morphology - The form and structure of streams.

Stream order - A hydrologic system of stream classification. Each small unbranched tributary is a first-order stream. Two first-order streams join to make a second-order stream. A third order stream has only first-and second-order tributaries, and so forth.

Stream reach - An individual segment of stream that has beginning and ending points defined by identifiable features such as where a tributary confluence changes the channel character or order.

Streambank erosion - The removal of soil from streambanks by flowing water.

Streambank stabilization - The lining of streambanks with riprap, matting, etc., or other measures intended to control erosion.

Streambed - (1) The unvegetated portion of a channel boundary below the baseflow level. (2) The channel through which a natural stream of water runs or used to run, as a dry streambed.

Substrate material - A layer beneath the surface soil.

Thalweg - (1) The lowest thread along the axial part of a valley or stream channel. (2) A subsurface, groundwater stream percolating beneath and in the general direction of a surface stream course or valley. (3) The middle, chief, or deepest part of a navigable channel or waterway.

Tributary - A stream that flows into another stream, river, or lake.

Udic moisture regime - Common to soils of humid climates which have well-distributed rainfall, or which have enough rain in summer so that the amount of stored moisture plus rainfall is approximately equal to, or exceeds, the amount of evapotranspiration.

Undercut - To cut away material from the underside of, so as to leave an overhanging portion in relief.

Vertisols - Soils that have a high content of expanding clay and that have at some time of the year have deep wide cracks. They shrink when drying and swell when they become wetter.

**APPENDIX L: RAPID GEOMORPHIC ASSESSMENTS
(RGA) CONDUCTED FOR THE
PROPOSED LOWER BOIS D'ARC CREEK
RESERVOIR SITE IN 2008 AND 2016**

**L-1: RAPID GEOMORPHIC ASSESSMENT OF BOIS D'ARC CREEK AND ITS
TRIBUTARIES FOR THE LOWER BOIS D'ARC CREEK RESERVOIR
PROJECT (2008)**

**L-2: SUPPLEMENTAL RAPID GEOMORPHIC ASSESSMENT DATA
COLLECTION AT THE PROPOSED LOWER BOIS D'ARC CREEK
RESERVOIR SITE (2016)**

MEMORANDUM



Innovative approaches
Practical results
Outstanding service

4055 International Plaza, Suite 200 • Fort Worth, Texas 76109 • 817-735-7300 • fax 817-735-7492

www.freese.com

TO: Robert McCarthy, NTMWD

CC: Simone Kiel, P.E.; Michael Votaw, P.W.S; Steve Watters, P.W.S, Stephanie Coffman, P.G.

FROM: David Coffman, P.G., C.F.M.; Velita Cardenas

SUBJECT: Supplemental Rapid Geomorphic Assessment (RGA) Data Collection at the Proposed Lower Bois d'Arc Creek Reservoir Site

DATE: March 1, 2016

PROJECT: NTD06128

1.0 INTRODUCTION

The North Texas Municipal Water District (NTMWD) is proposing to construct the Lower Bois d'Arc Creek Reservoir (LBCR) in Fannin County, TX. A rapid geomorphic assessment (RGA) of Bois d'Arc Creek and its four major tributaries within the footprint of the proposed LBCR was performed in 2008 to provide an estimate of baseline stream conditions (Freese and Nichols, 2008). At the time of this stream assessment, no functional or conditional stream assessment methods had been proposed, adopted, endorsed, or required by the U.S. Army Corps of Engineers (USACE) or other resource agencies having jurisdiction within the state of Texas. Applicants were encouraged to use best scientific judgement in employing tools to assess the function or condition of streams to be affected by the applicant's proposed project, LBCR. In March 2011 a draft methodology for stream (and wetland) condition assessment, Texas Rapid Assessment Method, Version 1.0 (TXRAM), was first published for use, testing, and public comment (USACE, 2011). The final TXRAM guidebook, Version 2.0, was issued by public notice published in October 2015 (USACE, 2015), seven years after fieldwork at the LBCR site was completed.

The data collection method and subsequent analysis used to assess the proposed LBCR site was also used to assess the streams on the proposed mitigation site, Riverby Ranch, in June 2014. A technical memorandum titled, *Proposed Mitigation for Stream Impacts of the Proposed Lower Bois d'Arc Creek Reservoir – Rapid Geomorphic Assessment* was submitted to NTMWD on November 12, 2014 ("the 2014 RGA memo"; see Attachment A). It described how RGA scores were calculated to characterize baseline condition of streams at both the LBCR site and at Riverby Ranch. The memo also outlined how the proposed stream mitigation would compensate for the stream impacts caused by the proposed LBCR (Freese and Nichols, 2014).

NTMWD submitted the 2014 RGA memo to the USACE, who subsequently distributed it to the Cooperating Agencies working with the USACE on the Clean Water Act, Section 404 permit for the proposed LBCR. These agencies include the U.S. Environmental Protection Agency (EPA), U.S. Fish and Wildlife Service (USFWS), the Texas Commission on Environmental Quality (TCEQ), and Texas Parks and Wildlife Department (TPWD). A workshop was held on October 13, 2015 to discuss the RGA method and its

application at the proposed reservoir site and the proposed mitigation site. The workshop was attended by representatives from USACE, EPA, USFWS, TCEQ, TPWD, NTMWD, and Freese and Nichols (See Attachment B).

During the workshop, the USACE and Cooperating Agencies requested additional RGA data be collected at the proposed reservoir site to supplement the 2008 data collection effort and assessment. In 2008, the RGA data collected on the main stem of Bois d'Arc Creek and four tributaries (Honey Grove Creek, Bullard Creek, Ward Creek, and Sandy Creek) were extrapolated to characterize all of the stream reaches in the proposed reservoir site. At the request of the resource agencies, the requested additional RGA data would be used to confirm the methodology used to characterize streams that were not directly measured in 2008.

The USACE worked with the Cooperating Agencies and NTMWD to identify 10 additional tributaries within the footprint of the proposed reservoir for additional RGA data collection. These tributaries included Allen's Creek, Burns Branch, Fox Creek, Onstott Creek, Pettigrew Branch, Sandy Branch, Stillhouse Branch, Timber Creek, Thomas Branch, and Yoakum Creek, with additional points on Honey Grove Creek, Sandy Creek, and Ward Creek. USACE approved the final locations of the additional RGA data collection sites via email to NTMWD and the Cooperating Agencies on December 7, 2015 (see Exhibit A and Attachment C).

The fieldwork to collect the supplemental RGA data took place during the week of January 11, 2016. Cooperating Agency members were invited to participate in the field data collection effort. In attendance during field work were Ed Parisotto and Robert Hoffman from USACE, Ryan McGillicuddy from TPWD, Robert McCarthy from NTMWD and Freese and Nichols staff.

The supplemental RGA data were collected using the same RGA methods as the previous investigations at the proposed reservoir site (2008) and the proposed mitigation site (2014) as described in the 2014 RGA memo (see Attachment A).



2.0 RESULTS

RGA scores from the supplemental data collected in January 2016 were converted to Stream Quality Factor (SQF) values and used to revise the total number of stream quality units (SQUs) that are present (i.e., that would be impacted) at the proposed reservoir site. Table 1 shows the length of stream within the proposed LBCR footprint by SQF and the corresponding SQUs after incorporating the January 2016 RGA data in the analysis.

Table 1. Summary of Proposed Reservoir Site SQUs Incorporating 2016 RGA Field Data

Stream Quality Factor (SQF)	Existing Length (ft)	Stream Quality Unit (SQU)
0 - .09	39,597	2,729
.1 - .19	116,842	15,512
.2 - .29	164,786	37,535
.3 - .39	125,191	40,463
.4 - .49	145,736	64,159
.5 - .59	58,872	31,519
.6 - .69	0	0
.7 - .79	0	0
.8 - .89	0	0
.9 - .99	0	0
1.0	0	0
Total	651,024	191,917



3.0 DISCUSSION OF RESULTS

Table 2 shows a comparison of the proposed reservoir site SQUs that were presented in the 2014 RGA memo (Attachment A) and the results incorporating the 2016 supplemental data. The total number of SQUs reported in the 2014 RGA memo were developed from an extrapolation of RGA data collected in 2008 from the main stem of Bois d’Arc Creek and its four major tributaries. The 2016 supplemental data collection effort expanded the observed and recorded stream conditions to include 10 additional tributaries of Bois d’Arc Creek and thereby improves on the extrapolation used in the 2014 RGA memo. In total, data were collected along the main stem of Bois d’Arc Creek and 14 tributaries within the footprint of the reservoir.

Table 2. Comparison of Proposed Reservoir Site SQUs with and without 2016 RGA Data

Stream Quality Factor (SQF)	Existing Length (ft)		Stream Quality Unit (SQU)	
	2014	2016	2014	2016
0 - .09	25,171	39,597	2,098	2,729
.1 - .19	91,337	116,842	11,592	15,512
.2 - .29	128,395	164,786	28,902	37,535
.3 - .39	73,580	125,191	23,013	40,463
.4 - .49	184,011	145,736	80,757	64,159
.5 - .59	141,422	58,872	77,835	31,519
.6 - .69	7,107	0	4,857	0
.7 - .79	0	0	0	0
.8 - .89	0	0	0	0
.9 - .99	0	0	0	0
1.0	0	0	0	0
Total	651,023	651,024	229,054	191,917



4.0 COMPENSATORY MITIGATION SUMMARY AND PROPOSED MITIGATION PLAN COMPONENTS

Based upon the supplemental data collection effort described in this memorandum, the total number of SQUs of Bois d’Arc Creek and its tributaries within the proposed reservoir pool, and therefore the total number of SQUs that would be impacted, is 191,917. As described in Attachment A, NTMWD has proposed four mitigation components to compensate for the impact of the proposed reservoir on streams.

As shown in Table 3, only the SQU uplift for Bois d’Arc Creek downstream of the proposed dam (generated by the proposed environmental flow regime, which would compensate for LBCR dam impacts as well as historical impacts due to channelization over the past century) are included in the total proposed mitigation. Based on re-assessment of impacts by incorporating the 2016 supplemental RGA data requested by the USACE and Cooperating Agencies, the total number of SQUs generated by the four proposed mitigation components would compensate for the stream losses in the proposed reservoir pool with a surplus of 1,417 SQUs.

Table 3. Baseline and mitigated SQUs for proposed stream mitigation components

Mitigation Component	Baseline SQU	Mitigated SQU
Riverby Ranch Stream Restoration and Enhancement	64,140	134,259
Riverby Ranch Stream Creation	0	23,806
Bois d’Arc Creek Downstream of Proposed Dam	N/A	5,974*
On-Site Tributaries to Littoral Zone Wetlands	21,840	29,295
Total Proposed Mitigation*	85,980	193,334**
Total Stream Impacts	191,917	
Total Stream SQU Surplus		1,417

*Uplift generated by improvement to Bois d’Arc creek downstream of proposed dam

**Uplift generated by WRP streams (4,797 SQUs) is not included in the total

5.0 REFERENCES

Freese and Nichols, 2008, Rapid Geomorphic Assessment of Bois d'Arc Creek and its Tributaries for the Lower Bois d'Arc Creek Reservoir Project: Prepared for North Texas Municipal Water District

Freese and Nichols, 2014, Proposed Mitigation for Stream Impacts of the Proposed Lower Bois d'Arc Creek Reservoir – Rapid Geomorphic Assessment: Prepared for North Texas Municipal Water District

U.S. Army Corps of Engineers. 2011. Joint Public Notice CESWF-11-TXRAM announcing release of the *Draft Texas Rapid Assessment Method (TXRAM), Wetland and Streams Modules, Version 1.0. Final Draft*. March 24, 2011.

U.S. Army Corps of Engineers. 2015. Joint Public Notice CESWF-11-TXRAM announcing release of the *Final Texas Rapid Assessment Method (TXRAM), Wetland and Streams Modules, Version 2.0*. October 13, 2015.

EXHIBITS

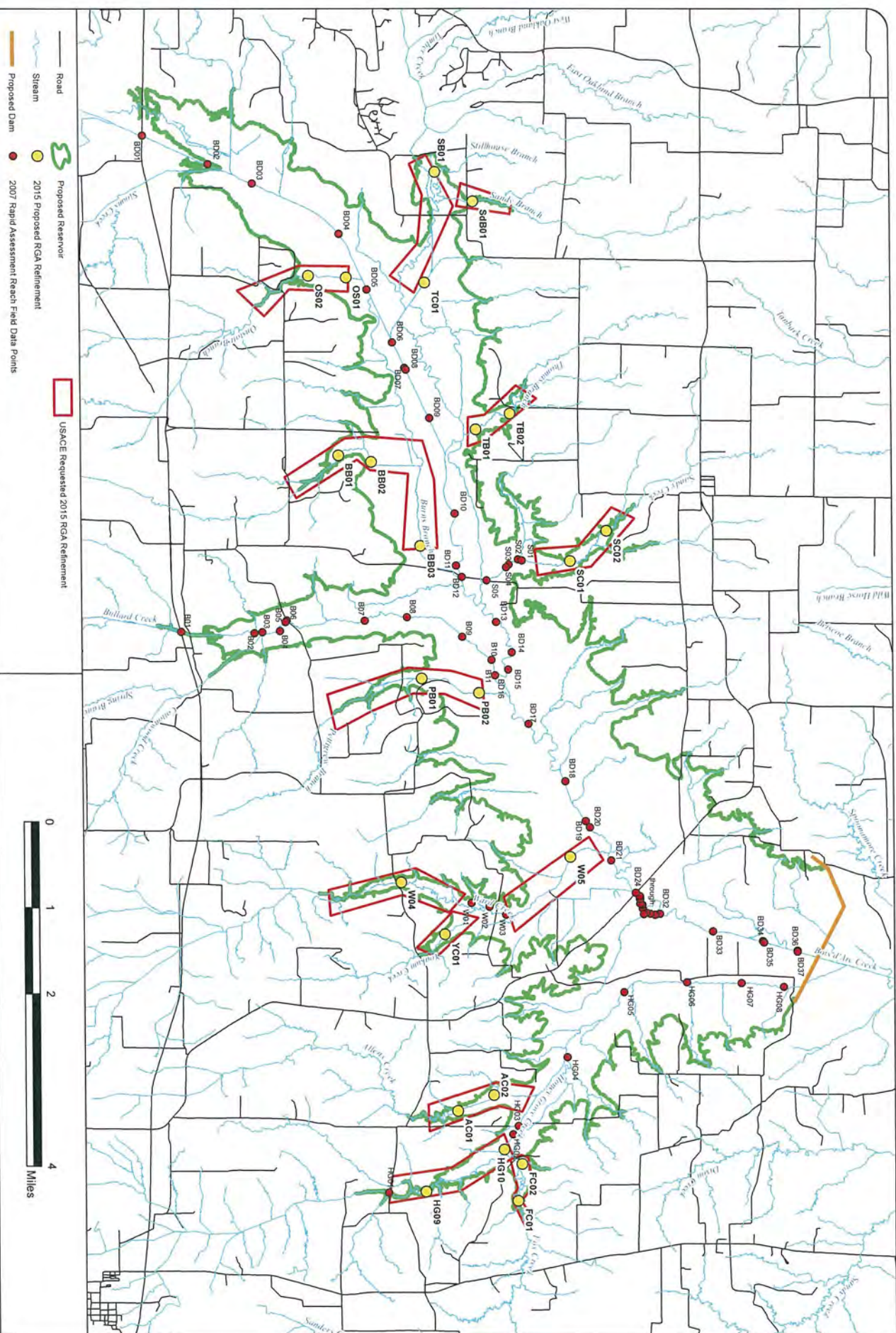

EXHIBIT A

Froese and Nichols
 4025 International Plaza
 Ste. 200
 Fort Worth, TX 76109
 Phone: (817) 735-7300
 Fax: (817) 735-7491

North Texas Municipal Water District
Proposed Lower Bois d'Arc Reservoir Project
2015 RGA Data Collection Points

PROJECT NO	NTD091328
DATE	December 4, 2015
DATUM & COORDINATE SYSTEM	NAD83 State Plane TX Central
FILE	IRGA_2015.mxd
PREPARED BY	VMC

Attachment A

Proposed Mitigation for Stream Impacts of the
Proposed Lower Bois d'Arc Creek Reservoir –
Rapid Geomorphic Assessment (Freese and
Nichols, 2014)

TECHNICAL MEMORANDUM



Innovative approaches
Practical results
Outstanding service

4055 International Plaza, Suite 200 • Fort Worth, Texas 76109 • 817-735-7300 • fax 817-735-7492

www.freese.com

TO: Robert McCarthy, NTMWD

CC: Simone Kiel, Randall Howard, Michael Votaw, Steve Watters

FROM: David Coffman, Stephanie Coffman, Velita Cardenas

SUBJECT: Proposed Mitigation for Stream Impacts of the Proposed Lower Bois d'Arc Creek Reservoir – Rapid Geomorphic Assessment

DATE: November 12, 2014; Corrected December 17, 2014

PROJECT: NTD06128

1.0 INTRODUCTION

The North Texas Municipal Water District (NTMWD) is proposing to perform mitigation for impacts to waters of the U.S. that would be caused by the proposed Lower Bois d'Arc Creek Reservoir project on the approximately 15,000 acre Riverby Ranch in northeast Fannin County, TX. Riverby Ranch is located approximately 25 miles northwest of Paris, Texas. The primary objectives of this study was to perform a rapid geomorphic assessment (RGA) of the creeks within Riverby Ranch (Exhibit 1), identify the mitigation potential of the ranch streams, and compare the mitigated condition of the ranch streams to the condition of the impacted streams within the proposed reservoir footprint. The RGA method is an analytical tool used to assess environmental impacts and project planning. The method is designed to describe stream quality at baseline and future conditions to allow for comparisons of the relative values of different areas at the same point in time or of the same area at different points in time.

A rapid geomorphic assessment (RGA) of Lower Bois d'Arc Creek and its four major tributaries within the footprint of the proposed Lower Bois d'Arc Creek Reservoir was performed in 2008 to provide an estimate of baseline stream conditions (Freese and Nichols, 2008). The data collection method and subsequent analysis used to assess the proposed Lower Bois d'Arc Creek Reservoir site was also used to assess the streams on Riverby Ranch. The field investigation component of the Riverby Ranch mitigation assessment took place on June 1-3, 2014. This report describes how RGA scores were calculated for both the proposed impacted and mitigation streams, and it outlines how the proposed stream mitigation would compensate for the stream impacts caused by the proposed reservoir.

Specifically, this memorandum covers the following topics:

- The RGA method and the calculation of Stream Quality Factor and Stream Quality Units
- RGA evaluation of the impacted streams at the proposed reservoir site
- Baseline condition assessment of five stream mitigation opportunities in the Bois d'Arc Creek watershed.
- The potential for ecological uplift in the mitigation streams generated through restoration and enhancement
- Proposed stream mitigation components to compensate for the impacts of the proposed reservoir

2.0 APPROACH AND METHODOLOGY

The following sub-sections provide descriptions of the RGA approach and how the RGA scores were used to derive Stream Quality Factor (SQF) and Stream Quality Unit (SQU) values for the proposed impact streams and mitigation streams. The rapid assessments were based on both anthropogenic and natural factors observed in the field and through comparison of the existing and historic channel pattern and geometry. The major factors evaluated were channel stability, vegetation/armoring, and potential in-stream habitat features. A description of the components used to develop the rapid stream assessments is presented below.

2.1 Rapid Geomorphic Assessment (RGA) Approach

The RGA approach integrates data from field and desktop sources into a quantitative and qualitative description of the features that affect stream stability and the potential for developing aquatic habitat features (Freese and Nichols, 2008). The RGA method is based on a rapid field assessment of stream properties and characteristics at representative field sites along the stream reaches being evaluated. Three forms are used to record data at each field point. The Data Collection sheet includes general stream information related to channel size and location. The Bank Stability form is used to record general bank geometry, information regarding riparian vegetation and rooting depths, and general bank armoring. The Channel Stability form is used to collect a variety of information related to the condition of the upper slopes, lower slopes, and channel bed. For each field point, data collected in the field forms are consolidated into a Channel Stability Rating System form. Examples of the four data forms are included in Appendix A. The following six categories are scored and summed to calculate a final RGA score for each field point out of a maximum possible 60 points, with higher values indicating more optimal stream conditions:

- Evidence of Bank Erosion
- Bank Root Zone
- Vegetative Bank Cover
- Bank Angle
- Sediment Transport
- Channel Alteration

2.2 Channel Stability Variables

Qualitative analysis of channel stability was the primary focus of the Rapid Geomorphic Assessment. The adverse consequences of stream channel instability are increased sediment supply, land loss, habitat deterioration, changes in long-term and short-term channel evolution, and loss of both physical and biological function of the stream.

Channel stability was inferred from field inspections, measurements of stream channel characteristics, and by comparing existing stream conditions to historic maps and aerial photography. Specific categories and variables included in the assessment were streambank erosion and angle, riparian and streambank vegetation, overall channel stability, sediment transport, and manmade channel alteration.

Streambank Erosion and Angle

The Bank Stability parameters included several related to the riparian vegetation and the bank angle. Although the Bank Erosion Hazard Index (BEHI) scoring system was not used, the method was referenced for help in determining the key parameters to be evaluated in relation to the channel erosion potential (Rosgen, 2006). Riparian vegetation plays a key role in bank stabilization. Banks with dense, deep rooting zones and in-channel vegetative cover in alluvium generally have stable banks while shallow, sparse roots and no in-stream vegetation result in unstable banks that are subject to mass wasting. Erosion potential related to bank angle (slope steepness) generally ranges from very low for flat slopes to extreme for steep slopes; however, there is a correction factor associated with bank angle to take into consideration the bank material (i.e. bedrock can be very stable at steep angles while sand and clay are not).

Riparian and Streambank Vegetation

Riparian vegetation performs several functions in a stream system including bank stabilization water quality protection, fish and wildlife habitat, and thermal cover for the stream. Bank stabilization and water quality are improved with good riparian buffers because the roots of trees and shrubs help hold stream banks in place, preventing erosion. Riparian vegetation also traps sediment and pollutants in land runoff before it reached the stream channel. The field data collected included information on the general type and condition of the riparian vegetation including an estimate of the percentage of the riparian vegetation that was trees, shrubs, and grasses. Rooting depth, root density and the percentage of the bank protected by vegetation are specific measurements that were taken at each data point. This information was used in both the preliminary bank stability and channel stability classifications.

Channel Stability

The channel stability rating system utilized for this assessment is based on the measurement of up to 15 variables that are specific to the channel bottom, the lower banks within the channel, and the upper banks of the channel. Although the Rosgen-Pfankuch rating system was not used, the method was referenced for help in determining the key parameters to be evaluated in relation to channel stability (Rosgen, 2006). The channel stability rating process evaluates the upper banks, lower banks, and streambed for evidence of excessive erosion or deposition, which are indicative of disequilibrium and can be used to identify potential aquatic habitat within a stream. The system quantitatively evaluates the potential for mass wasting of the channel banks, the detachability of bank and bed materials, channel capacity, and evidence of either excessive erosion or deposition. The process provides a means for estimating general channel stability.

Sediment Transport

The description of depositional features utilized for this study is from Mollard (1973) and Galay et al. (1973) as modified by Rosgen (2006). Depositional features, or lack thereof, can be an indicator of channel aggradation or degradation and signal that the channel is experiencing instabilities. Field observations and interpretations of the depositional patterns were used in estimating the sediment transport competency of the channel. Depositional patterns in altered or degraded channel reaches aided in estimating the long-term stability of the channel reach under existing flow conditions.

Photographs

In addition to the data discussed above, GPS-tagged photographs were taken at each data collection point to record visual observations. Photographs looking upstream and downstream were taken at each data point and, at some locations, photographs of the right and left banks were also taken.

Historical Aerial Photography

Current and historical aerial photographs of Riverby Ranch were used to evaluate changes in stream patterns, land use practices, and riparian vegetation over time. The impacts of these changes on the channel pattern and profile were evaluated and documented.

2.3 Channel Stability Rating System

All of the variables discussed in Section 2.2 were assessed for each data point and consolidated into a Channel Stability Rating System form (Appendix A). The data were then used to determine a general RGA score (ranging from zero (0) to 60) for that portion of the creek. These classification sheets were then used in conjunction with field notes, aerial photographs, one-foot LIDAR generated topography and two-foot aerial topography to relate the measured and observed sections of the study reaches to other sections of the creeks to determine their RGA score. The stability rating system was developed by Freese and Nichols to provide an objective means for assigning values to the six major parameters identified on the Channel Stability Rating System form. In order to provide a quantitative measurement of the six evaluation factors, the system relies on the physical parameters measured and recorded on the data collection sheet, bank stability form, and channel stability form. Data are first recorded in the field on those forms and select photographs are attached for future reference. Finally, the information on those three forms is used to complete the Channel Stability Rating System form and subsequently calculate the RGA score. The weighting and scoring system was developed to provide an objective means for interpreting the data and classifying the stream reaches.

2.4 Stream Quality Factor

The RGA score (a number between zero (0) and 60) for a particular study site is normalized into a Stream Quality Factor (SQF) value by dividing the calculated RGA score by the maximum possible score of 60 points. SQF values are a quality weighting factor that are used to quantify the comparison between baseline stream characteristics of the study site to the stream conditions that are ecologically optimal. This SQF value is used to place a value on the impacted streams and to evaluate the success of the proposed stream mitigation. As with the RGA score, the higher the SQF, the higher the stream quality as based on geomorphic stream equilibrium.

2.5 Stream Quality Unit

The calculated SQF score for a study reach is multiplied by the length of the respective study reach to calculate the number of Stream Quality Units (SQUs) provided by the reach. SQUs quantify the relationship between stream characteristics and the length of stream with those particular characteristics. SQUs allow for an unbiased comparison of the condition of one reach of stream to another, regardless of the length of stream being compared.

3.0 EVALUATION OF PROPOSED STREAM IMPACTS FOR LOWER BOIS D’ARC RESERVOIR

Freese and Nichols (2008) provided RGA scores for Bois d’Arc Creek and its larger tributaries (Honey Grove Creek, Ward Creek, Sandy Creek and Bullard Creek) within the proposed reservoir pool. The RGA scores for these assessed streams were converted to SQF values, and subsequently, the number of SQUs were calculated using the SQF value and the associated reach length. SQF values from the assessed streams were extrapolated to the tributaries upstream of the assessed reaches based on the location of the tributary confluence. For example, if a study reach of Honey Grove Creek had an SQF value calculated to be 0.25, then a stream tributary to that study reach was assumed to also have an SQF value of 0.25. The total SQUs of Bois d’Arc Creek and its tributaries within the proposed reservoir pool, designated by the summed product of the SQU scores for all proposed impact streams and the respective lengths of proposed impacted stream, is 229,054. Table 1 shows the length of stream within the Lower Bois d’Arc Creek footprint by SQF and the corresponding calculated SQUs.

Table 1. Summary of Proposed Project Stream Impacts

Stream Quality Factor (SQF)	Existing Length (ft)	Stream Quality Unit (SQU)
0 - .09	25,171	2,098
.1 - .19	91,337	11,592
.2 - .29	128,395	28,902
.3 - .39	73,580	23,013
.4 - .49	184,011	80,757
.5 - .59	141,422	77,835
.6 - .69	7,107	4,857
.7 - .79	0	0
.8 - .89	0	0
.9 - .99	0	0
1.0	0	0
Total	651,023 651,024	229,054

4.0 DESCRIPTIONS OF POTENTIAL STREAM MITIGATION OPPORTUNITIES

A number of opportunities have been identified that would provide compensatory stream mitigation for the impacts to streams caused by the construction of the proposed Lower Bois d'Arc Creek Reservoir. The five identified potential opportunities are as follows:

- Riverby Ranch existing stream restoration and enhancement
- Riverby Ranch stream creation by restoring meanders on straightened/channelized streams
- Bois d'Arc Creek downstream of the proposed dam
- On-site tributaries to littoral zone wetlands
- Riverby Ranch Wetlands Reserve Program (WRP) area stream enhancement

The following subsections briefly describe the five stream mitigation opportunities and how they were individually assessed using the RGA methodology.

4.1 Riverby Ranch Existing Stream Restoration and Enhancement

Riverby Ranch (excluding areas enrolled in the Wetlands Reserve Program (WRP)) contains 179,353 linear feet of ephemeral and intermittent streams that have been degraded over time by agricultural practices. During the RGA study of Riverby Ranch, 36 field points were evaluated to quantify characteristics of the existing streams on the ranch outside the WRP area. The streams were each given a unique identifier/name and were divided into reaches based on morphological characteristics, cover types, stream order, tributary confluences, and field point RGA score.

4.2 Riverby Ranch Stream Creation

As stated in the January 2014 Proposed Lower Bois d'Arc Creek Reservoir Mitigation Plan (Freese and Nichols, 2014), the North Texas Municipal Water District is proposing to restore meanders to several first and second-order streams located on the ranch that have been historically straightened/channelized. Field observations and evaluation of current and historical aerial photographs were used to select existing streams on the ranch that would be suitable for meander creation and to calculate an appropriate sinuosity ratio for the created meanders. It was determined that a sinuosity ratio of 1.3 would be a reasonable ratio for the restored channels. Application of the 1.3 sinuosity ratio to streams suitable for meander creation results in 30,084 additional linear feet of meandering stream on the ranch. The additional linear feet are only considered during the future conditions analysis because there are no baseline conditions present prior to the construction of the created meanders.

4.3 Bois d'Arc Creek Downstream of Proposed Dam

The RGA method was used to evaluate the baseline condition and potential future condition of the channel of Bois d'Arc Creek downstream of the proposed dam. It is anticipated that the existing condition of Bois d'Arc Creek downstream of the proposed dam will improve as a result of the hydrologic stability inherent in the proposed environmental flow regime. Two RGA field points on Bois d'Arc Creek were located to coincide with the stream reaches studied during the Inter-Agency Team Instream Flow Study conducted in 2010. One RGA field point was located upstream of the FM 409 bridge crossing, and a second field point



was on USFS property upstream of Riverby Ranch, (Exhibit 1). Bois d'Arc Creek was divided into reaches between the proposed dam and the Red River as follows:

- Proposed dam to FM 100
- FM 100 to the southern boundary of Riverby Ranch
- Three (3) reaches within the WRP area within Riverby Ranch
- Northern boundary of Riverby Ranch to the Red River

4.4 On-site Tributaries to Littoral Zone Wetlands

The RGA method was used to evaluate the baseline condition and potential future conditions of the tributary streams of the littoral zone wetlands that will form between elevations 534 and 541 ft. msl as a result of the proposed impoundment of Bois d'Arc Creek. The baseline RGA scores of the littoral zone tributary streams were extrapolated from the downstream stream reaches within the conservation pool of the proposed reservoir.

4.5 Riverby Ranch WRP

There are approximately 67,496 linear feet of stream channel within the WRP area on Riverby Ranch, excluding the channel of Bois d'Arc Creek. During the RGA study of Riverby Ranch, eight (8) field points were evaluated to quantify characteristics of the existing streams in the WRP area. The study area within the WRP was divided into reaches based on morphological characteristics, cover types, stream order, tributary confluences, and field point RGA score.

5.0 BASELINE CONDITIONS OF PROPOSED MITIGATION STREAMS

The following section discusses the calculations and results for baseline conditions of the potential mitigation opportunities. Table 2 presents a summary of the baseline conditions for the potential stream mitigation opportunities.

5.1 Riverby Ranch Existing Stream Restoration and Enhancement

RGA scores were applied to reaches based on the score of the most representative nearby field data point. The RGA score for reaches with two field data points was calculated as the average of the two field data points. The RGA scores for stream reaches that did not contain field data points were extrapolated from reaches with similar characteristics. Exhibit 2 illustrates the locations of the field data points and stream reaches on Riverby Ranch. The RGA score for each reach was converted to an SQF value, which was then multiplied by the length of the respective reach to calculate the SQU. The total baseline SQU value for Riverby Ranch, defined as the sum of the SQUs for each reach, was calculated to be 64,140. This total does not include streams within the WRP area.

5.2 Riverby Ranch Stream Creation

The restoration of meanders for historically straightened/channelized streams will create additional stream length that does not currently exist. For mitigation accounting purposes, the additional created stream length was designated a baseline RGA score and SQF of zero. Total number of baseline SQUs for this component was assumed to be zero due to the absence of preexisting stream length and the RGA score and SQF value of zero.

5.3 Bois d'Arc Creek Downstream of Proposed Dam

The RGA scores for the reaches containing the FM 409 and USFS field points were designated based on their respective field point RGA score. For the segment of Bois d'Arc Creek within the WRP area, reach RGA scores were designated based on their respective field points within the WRP. The RGA score for the reach of Bois d'Arc Creek north of the Riverby Ranch boundary was extrapolated from a representative field point on Bois d'Arc Creek within the WRP area. The reach RGA scores were converted into SQF values, which were then multiplied by the lengths of the respective stream reaches to calculate the SQUs for the reaches. The total number of baseline SQUs for Bois d'Arc Creek downstream of the proposed dam, defined as the sum of the SQUs for each reach of Bois d'Arc Creek downstream of the proposed dam, was calculated to be 45,673.

5.4 On-site Tributaries to Littoral Zone Wetlands

RGA scores for stream reaches within the pool of the proposed reservoir were extrapolated to the streams tributaries to the littoral zone wetlands between elevations 534 and 541 ft. msl. The RGA scores for the tributaries of the littoral zone wetlands were converted into SQF values, then multiplied by the stream length to calculate the total number of SQUs for each reach. The total baseline SQU value for the on-site littoral zone wetlands tributary streams was calculated to be 21,840.



5.5 Riverby Ranch WRP

The RGA scores for the tributary streams in the WRP area were calculated the same way as the reaches throughout Riverby Ranch. The RGA scores were converted into SQF values, which were then multiplied by the lengths of the respective reaches to calculate the SQUs for each reach within the WRP area. The total number of baseline SQUs for tributary reaches within the WRP area, defined as the sum of the SQUs for each reach within the WRP area, was calculated to be ~~17,117~~ 28,561.

Table 2. Summary of the Baseline Conditions for the Potential Mitigation Opportunities

SQF	Riverby Ranch, Excluding WRP		Bois d'Arc Creek Downstream of Proposed Dam		Tributaries of Littoral Zone		Tributaries within the WRP Area	
	Existing Length (ft)	SQU	Existing Length (ft)	SQU	Existing Length (ft)	SQU	Existing Length (ft)	SQU
0 - .09	8,507	457	0	0	37,717	3,143	7,649	382
.1 - .19	26,966	4,253	0	0	6,973	813	888	163
.2 - .29	47,790	10,764	0	0	14,550	3,079	0	0
.3 - .39	14,086	4,991	40,184	14,734	4,363	1,309	16,026	5,342
.4 - .49	37,838	17,395	65,893	30,939	10,175	4,455	19,621	9,075
.5 - .59	29,393	15,818	0	0	13,555	7,583	23,313	13,599
.6 - .69	10,905	7,239	0	0	2,131	1,456	0	0
.7 - .79	0	0	0	0	0	0	0	0
.8 - .89	3,868	3,223	0	0	0	0	0	0
.9 - .99	0	0	0	0	0	0	0	0
1.0	0	0	0	0	0	0	0	0
Total	179,353	64,140	106,077	45,673	89,465	21,840	67,496	28,561

1. Stream Creation is not shown because the baseline conditions are "0".

6.0 EVALUATION OF POTENTIAL MITIGATION STREAM IMPROVEMENTS

The following section discusses the calculations and results for the potential future conditions of the identified mitigation opportunities. Stream quality improvement potential was estimated assuming appropriate application of potential stream improvement practices. Measures to attain the intended ecological uplift vary from site to site and may include one or more of the following practices:

- Laying back stream banks to reduce erosion and allow for vegetation establishment
- Removal of cattle and other negative anthropogenic influences
- Plugging or diverting drainage ditches
- Restoring meanders to stream channels which were previously straightened
- Establishing a balanced sediment supply

The potential improvement practices directly correspond with the variables on the Channel Stability Rating System form, shown in Appendix A. For example, Table 3 shows that the calculated baseline RGA score for Bois d’Arc Tributary 2, Reach 1 (Figure 1) on Riverby Ranch was determined to be 3 out of 60 possible points, and the improved RGA score due to the application of improvement practices was 47 out of 60 possible points. The stream improvement practices and their expected results that provide the anticipated ecological uplift for this reach are shown in Table 4. Table 5 presents a summary of the mitigated conditions for the potential stream mitigation opportunities.

Table 3. Calculated baseline and potential improved RGA scores for Bois d’Arc Creek Tributary 2, Reach 1

Evaluation Category	Baseline RGA Score	Mitigated RGA Score
Evidence of Bank Erosion	0	8
Bank Root Zone	1	8
Vegetative Cover	2	9
Bank Angle	0	10
Sediment Transport	0	2
Channel Alteration	0	10
Total	3	47

Figure 1. Photograph looking upstream at reach of Bois d'Arc Creek Tributary 2, Reach 1





Table 4. Stream improvement practices and anticipated results for Bois d’Arc Creek Tributary 2, Reach 1

Improvement Practice	Post-Restoration Condition
Decrease streambank angle	Reduces the steepness of the streambank, allows for streambank vegetation to become established, reduces sediment supply from eroding streambanks, and increases floodplain connectivity
Reshaping the channel	Reduces sediment supply from eroding streambanks, increase floodplain connectivity, improves groundwater/surface water exchange, establishes vertical and lateral stability, improves sediment transport capacity, improves bed form diversity, generates habitat, and improves water quality
Establish streambank vegetation and plant riparian buffer	Provides streambank stability, improves vegetated bank cover and bank root zone, provides shade and generates wood debris storage/habitat, reduces bank erosion, and improves water quality
Channelized stream converted to meandering systems	Provides adequate flow duration, increases floodplain connectivity, improves groundwater/surface water exchange, reduces sediment supply from eroding streambanks, establishes vertical and lateral stability, improves sediment transport capacity, improves bed form diversity, generates habitat and biodiversity, and improves water quality
Remove livestock	Improves vegetated bank cover and bank root zone, provides shade and generates wood debris storage, habitat and biodiversity, reduces bank erosion, reduces sediment supply from eroding streambanks and improves bed form diversity, and improves water quality
Terminate agricultural practices	Improves vegetated bank cover and bank root zone, provides shade and generates wood debris storage, habitat and biodiversity, reduces bank erosion, reduces sediment supply from eroding streambanks and improves bed form diversity and improves water quality

6.1 Riverby Ranch Existing Stream Restoration and Enhancement

Mitigated SQUs for the reaches were calculated by estimating the uplift potential for each reach on the ranch and designating an uplift RGA score and SQF for the reach. Uplift potential was estimated assuming appropriate application of potential stream improvement practices. The mitigated SQUs for the reaches were calculated as a product of reach length and reach mitigated SQF. Reach mitigated SQUs were summed to calculate the total number of mitigated SQUs for the Riverby Ranch Property of 134,259, excluding streams in the WRP area.

6.2 Riverby Ranch Stream Creation

Mitigated RGA scores for the additional created stream length were extrapolated from the mitigated RGA scores of the associated stream. For example, if a straightened stream channel was estimated to receive a mitigated RGA score of 40, the additional stream length associated with that stream (calculated using a sinuosity ratio of 1.3) was also given a RGA score of 40. The RGA scores of the additional created stream length were converted to SQF values. The SQUs of the created stream length for each reach were calculated as the product of the mitigated SQF values and the anticipated additional created stream length for each reach. The total number of SQUs for created stream length on Riverby Ranch was calculated as the sum of the SQUs of the created stream length for each reach in which meanders were developed. The total number of SQUs for the created stream length resulting from the restoration of meanders was calculated to be 23,806. Stream reaches in the WRP were not considered suitable for meander creation.

6.3 Bois d'Arc Creek Downstream of Proposed Dam

Changes in the hydrologic regime of Bois d'Arc Creek downstream of the proposed dam are expected to provide sufficient flows to benefit and maintain habitat and not cause erosion and channel degradation. Based on this assumption, RGA scores are expected to improve for the reaches of Bois d'Arc Creek downstream of the proposed dam. Mitigated RGA scores were converted to SQF values, which were used to calculate the mitigated SQUs for the reaches, defined as the product of reach length and reach SQF. Reach mitigated SQUs were summed to calculate a total number of mitigated SQUs for Bois d'Arc Creek downstream of the proposed dam. The total number of mitigated SQUs for Bois d'Arc Creek downstream of the proposed dam was calculated to be 51,646.

6.4 On-site Tributaries to Littoral Zone Wetlands

The proposed mitigation plan intends to offer protection from future development and other non-compatible uses by establishing a conservation easement up to elevation 541 ft. msl. at the proposed reservoir site. The cessation of farming practices such as the application of fertilizers and pesticides, removing cattle and other negative anthropogenic influences will benefit the littoral zone tributary streams and provide ecological uplift. The uplift due to the establishment of a conservation easement and the removal of human influences is expected to be at least five (5) RGA points. Five RGA points were added to the baseline RGA score for each tributary stream to establish the mitigated RGA scores within the littoral zone wetlands. The mitigated RGA scores were converted to SQF values, which were used to calculate the SQUs, defined as the product of the SQF and the length of littoral zone tributary streams. The total number of mitigated SQUs for tributaries of the littoral zone wetlands, defined as the sum of all mitigated SQUs for the littoral zone tributary streams, was calculated to be 29,295.

6.5 Riverby Ranch WRP

Fluvial geomorphic principles support the hypothesis that as upstream reaches of streams are improved and become stabilized, the downstream reaches of channel can experience indirect ecological uplift as a result of the upstream improvements, even with no direct channel work performed in the downstream reaches. For example, removing cattle and other agricultural practices, restoring meanders, modifying channel geometry to stable dimensions, and re-connecting the upstream channel to a floodplain would promote stability and provide uplift to the downstream reach by reducing the volume and velocity of incoming stream flow (thereby reducing channel erosion and bank failures), reducing incoming sediment and nutrient loads (that promote channel infilling and eutrophication), and providing a seed source for channel vegetation.

Mitigated RGA scores for the streams in the WRP that were directly connected to upstream tributaries outside the WRP area were assigned based on the existing condition of the WRP streams and the anticipated future condition that would result from indirect uplift caused by upstream channel restoration efforts. Mitigated RGA scores were converted to mitigated SQF values, and the mitigated SQUs for the WRP stream reaches were calculated as the product of length of the stream reach within the WRP area and the reach mitigated SQUs. Reach mitigated SQUs were summed to calculate the total number of mitigated SQUs for the streams in the WRP area on Riverby Ranch of ~~20,067~~ 33,358.



Table 5. Summary of the Mitigated Conditions for the Potential Mitigation Opportunities

SQF	Riverby Ranch, Excluding WRP		Riverby Ranch Stream Creation		Bois d'Arc Creek Downstream of Proposed Dam		Tributaries of Littoral Zone		Tributaries within the WRP Area	
	Mitigated Length (ft)	SQU	Mitigated Length (ft)	SQU	Mitigated Length (ft)	SQU	Mitigated Length (ft)	SQU	Mitigated Length (ft)	SQU
0 - .09	0	0	0	0	0	0	0	0	0	0
.1 - .19	0	0	0	0	0	0	37,717	6,286	4,502	825
.2 - .29	7,562	2,017	0	0	0	0	11,372	2,641	3,045	791
.3 - .39	0	0	0	0	0	0	14,515	4,718	0	0
.4 - .49	1,012	472	0	0	40,184	17,413	4,397	2,125	23,048	9,638
.5 - .59	0	0	0	0	65,893	34,233	5,779	3,178	13,588	7,240
.6 - .69	29,423	19,378	510	323	0	0	13,555	8,713	23,313	14,864
.7 - .79	96,195	74,879	20,867	16,345	0	0	2,131	1,634	0	0
.8 - .89	45,160	37,513	8,708	7,138	0	0	0	0	0	0
.9 - .99	0	0	0	0	0	0	0	0	0	0
1.0	0	0	0	0	0	0	0	0	0	0
Total	179,353	134,259	30,084	23,806	106,077	51,646	89,465	29,295	67,496	33,358



7.0 COMPENSATORY MITIGATION SUMMARY AND PROPOSED MITIGATION PLAN COMPONENTS

The total number of SQUs of Bois d’Arc Creek and its tributaries within the proposed reservoir pool is 229,054. Of the five (5) potential stream mitigation opportunities discussed above, only four (4) will be included in the proposed mitigation plan to compensate for the impact of the proposed reservoir. Mitigation for the impacted streams would be achieved through the four (4) mitigation components listed in Table 5.

As shown in Table 6, only the SQU uplift for Bois d’Arc Creek downstream of the proposed dam (generated by the stabilized flow regime) are included in the total proposed mitigation. Additionally, the streams located within the WRP area are currently protected in perpetuity under the WRP instrument, and the NRCS has instructed the NTMWD that no earthwork is to be done to streams within the WRP area. The total number of SQUs generated by the four preferred mitigation components compensate for the stream losses in the proposed reservoir pool with a deficit of ~~36,345~~ 35,720 SQUs. Table 5 summarizes the total number of baseline and mitigated condition SQUs for the four proposed mitigation components.

Table 6 Baseline and mitigated SQUs for proposed stream mitigation components

Mitigation Component	Baseline SQU	Mitigated SQU
Riverby Ranch Restoration and Enhancement	63,632 64,140	133,634 134,259
Riverby Ranch Creation	0	23,806
Bois d’Arc Creek Downstream of Proposed Dam	N/A	5,974*
On-Site Tributaries to Littoral Zone Wetlands	21,840	29,295
Total Proposed Mitigation*	85,472 85,980	192,709** 193,334**
Total Stream Impacts	229,054	
Total Stream SQU Deficit		36,345 35,720

*Uplift generated by improvement to Bois d’Arc creek downstream of proposed dam

**Uplift generated by WRP streams (~~2,951~~ 4,797 SQUs) is not included in the total





Technical Memorandum

November 12, 2014; Corrected December 17, 2014

Page 17 of 19

8.0 REFERENCES

FNI, 2008, Rapid Geomorphic Assessment of Bois d'Arc Creek and its Tributaries for the Lower Bois d'Arc Creek Reservoir Project: Prepared for North Texas Municipal Water District

FNI, 2014, Mitigation Plan for the Proposed Lower Bois d'Arc Creek Reservoir, January 2014: Prepared for North Texas Municipal Water District

Rosgen, David, 2006, Watershed Assessment of River Stability and Sediment Supply: Wildland Hydrology, Fort Collins, CO.

Exhibits

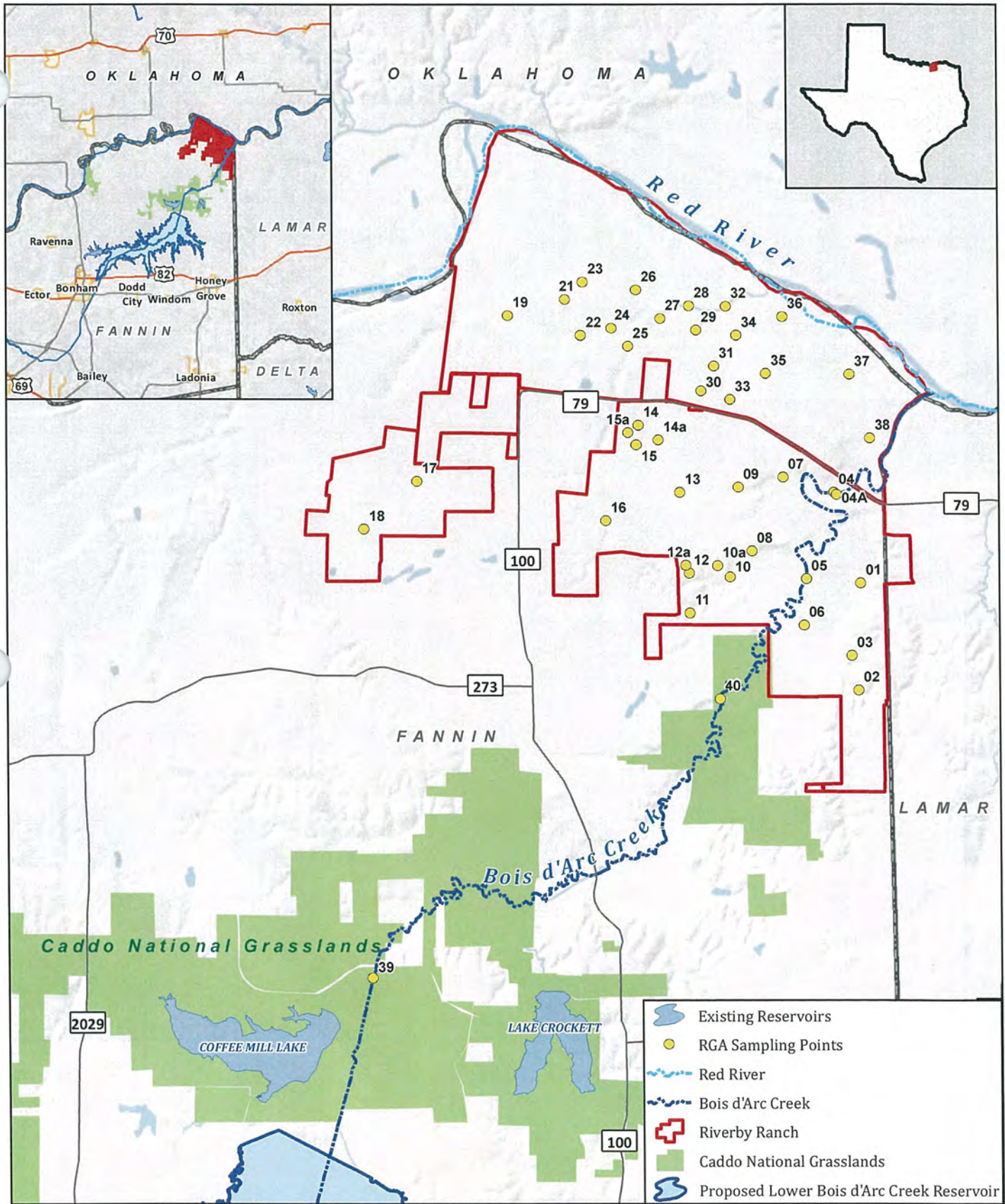

FREESSE NICHOLS
 Freese and Nichols, Inc.
 4055 International Plaza Suite 200
 Fort Worth, Texas 76109-4895
 817-735-7300



NORTH TEXAS MUNICIPAL WATER DISTRICT

Riverby Ranch Location Map

0 2 4
Miles

FN JOB NO	NTD06128
FILE NAME	Location.mxd
DATE	8/5/2014
SCALE	1:96,411
DESIGNED	SSJ
DRAFTED	SSJ

1

EXHIBIT

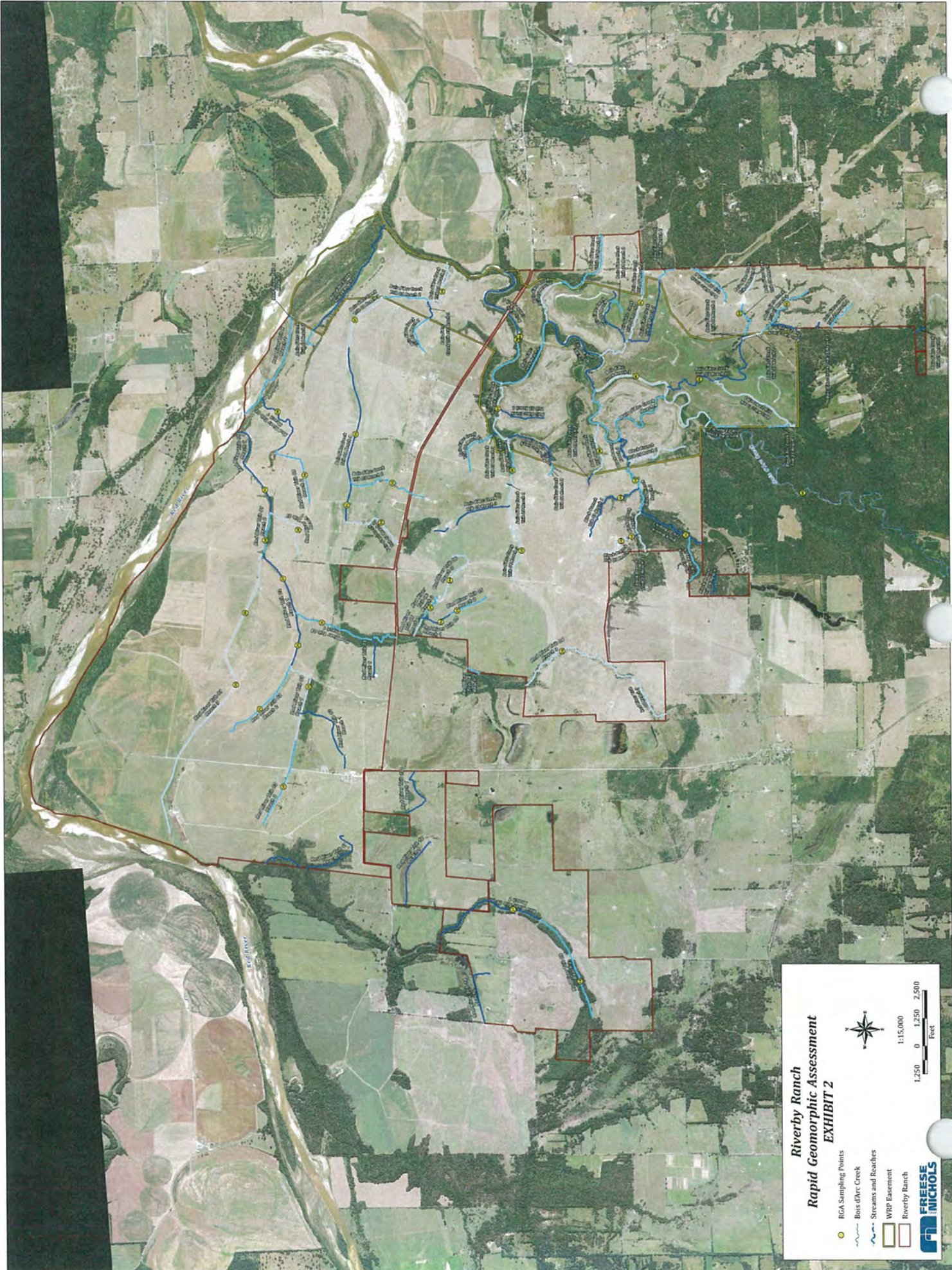

**Riverby Ranch
Rapid Geomorphic Assessment
EXHIBIT 2**

- RGA Sampling Points
- Bois d'Arc Creek
- Streams and Reaches
- WRP Easement
- Riverby Ranch

1:15,000

1,250 0 1,250 2,500
Feet

**FREESE
NICHOLS**

Appendix A

Example RGA Field Forms and Channel Stability Rating System Form

Pfankuch Channel Stability Form

Stream: _____ Reach: _____ Date: _____ Observers: _____ Comments: _____

Location	Key	Category	Excellent			Good			Fair			Poor		
			Description	Rating	Description	Rating	Description	Rating	Description	Rating	Description	Rating		
Upper Banks	1	Landform Slope	Bank slope gradient <30%.	2	Bank slope gradient 30-40%.	4	Bank slope gradient 40-60%.	6	Bank slope gradient 60%+.	8	Bank slope gradient 60%+.	8	Bank slope gradient 60%+.	
	2	Mass Wasting	No evidence of past or future mass wasting.	3	Infrequent. Mostly healed over. Low future potential.	6	Frequent or large, causing sediment nearly year long.	9	Frequent or large, causing sediment nearly year long.	12	Frequent or large, causing sediment nearly year long OR imminent danger of same.	12	Frequent or large, causing sediment nearly year long OR imminent danger of same.	
	3	Debris Jam Potential	Essentially absent from immediate channel area.	2	Present, but mostly small twigs and limbs.	4	Present, but mostly small twigs and limbs.	4	Moderate to heavy amounts, mostly larger sizes.	6	Moderate to heavy amounts, mostly larger sizes.	8	Moderate to heavy amounts, predominantly larger sizes.	
	4	Vegetative Bank Protection	90%+ plant density. Vigor and variety suggest a deep, dense soil binding root mass.	3	70-90% density. Fewer species or less vigor suggest less dense or deep root mass.	6	50-70% density. Lower vigor and fewer species from a shallow, discontinuous root mass.	9	50-70% density. Lower vigor and fewer species from a shallow, discontinuous root mass.	9	<50% density plus fewer species & less vigor indicating poor, discontinuous, and shallow root mass.	12	<50% density plus fewer species & less vigor indicating poor, discontinuous, and shallow root mass.	
Lower Banks	5	Channel Capacity	Adequate. Bank overflows are rare. (W/D)/(W/Dref) = 1.1 - 1.2, BHR = 1.1 - 1.3	1	Adequate. Bank overflows are rare. (W/D)/(W/Dref) = 1.1 - 1.2, BHR = 1.1 - 1.3	2	Barely contains present peaks. Occasional overbank floods. (W/D)/(W/Dref) = 1.2 - 1.6, BHR = 1.3 - 1.5	2	Barely contains present peaks. Occasional overbank floods. (W/D)/(W/Dref) = 1.2 - 1.6, BHR = 1.3 - 1.5	3	Inadequate. Overbank flows common. (W/D)/(W/Dref) > 1.6, BHR > 1.5	4	Inadequate. Overbank flows common. (W/D)/(W/Dref) > 1.6, BHR > 1.5	
	6	Bank Rock Content	65%+ w/ large angular boulders. 12"+ common.	2	40-65%. Mostly boulders and small cobbles 6-12".	4	20-40%. With most in the 3-6" diameter class.	4	20-40%. With most in the 3-6" diameter class.	6	<20% rock fragments of gravel sizes, 1-3" or less.	8	<20% rock fragments of gravel sizes, 1-3" or less.	
	7	Obstructions to Flow	Rocks and logs firmly embedded. Flow pattern w/o cutting or deposition. Stable bed.	2	Some present causing erosive cross currents and minor pool filling. Obstructions fewer and less firm.	4	Moderately frequent, unstable obstructions move with high flows causing bank cutting and pool filling.	4	Moderately frequent, unstable obstructions move with high flows causing bank cutting and pool filling.	6	Frequent obstructions and deflectors cause bank erosion yearlong. Sediment traps full, channel migration occurring.	8	Frequent obstructions and deflectors cause bank erosion yearlong. Sediment traps full, channel migration occurring.	
	8	Cutting	Little or none. Infrequent raw banks <6".	4	Some, intermittently at outcaves and constrictions. Raw banks may be up to 12".	6	Significant. Cuts 12-24" high. Root mat overhangs and sloughing evident.	12	Significant. Cuts 12-24" high. Root mat overhangs and sloughing evident.	12	Almost continuous cuts, some over 24" high. Failure of overhangs frequent.	16	Almost continuous cuts, some over 24" high. Failure of overhangs frequent.	
	9	Deposition	Little or no enlargement of channel or point bars.	4	Some new bar increase, mostly from coarse gravel.	8	Moderate deposition of new gravel and coarse sand on old and some new bars.	8	Moderate deposition of new gravel and coarse sand on old and some new bars.	12	Extensive deposit of predominantly fine particles. Accelerated bar development.	16	Extensive deposit of predominantly fine particles. Accelerated bar development.	
Bottom	10	Rock Angularity	Sharp edges and corners. Plane surfaces rough.	1	Rounded corners and edges, surfaces smooth, flat.	2	Comers and edges well rounded in 2 dimensions.	2	Comers and edges well rounded in 2 dimensions.	3	Well rounded in all dimensions, surfaces smooth.	4	Well rounded in all dimensions, surfaces smooth.	
	11	Brightness	Surfaces dull, dark or stained. Generally not bright.	1	Mostly dull, but may have <35% bright surfaces.	2	Mixture dull and bright, i.e. 35-55% mixture range.	2	Mixture dull and bright, i.e. 35-55% mixture range.	3	Predominantly bright, 65%+, exposed or scoured surfaces.	4	Predominantly bright, 65%+, exposed or scoured surfaces.	
	12	Consolidation of Particles	Assorted sizes tightly packed or overlapping.	2	Moderately packed with some overlapping.	4	Mostly loose assortment with no apparent overlap.	4	Mostly loose assortment with no apparent overlap.	6	No packing evident. Loose assortment, easily moved.	8	No packing evident. Loose assortment, easily moved.	
	13	Bottom Size Distribution	No size change evident. Stable material 80-100%.	4	Distribution shift light. Stable material 50-80%.	8	Moderate change in sizes. Stable materials 20-50%.	8	Moderate change in sizes. Stable materials 20-50%.	12	Marked distribution change. Stable materials 0-20%.	16	Marked distribution change. Stable materials 0-20%.	
	14	Scouring and Deposition	<5% of bottom affected by scour or deposition.	6	5-30% affected. Scour at constrictions and where grades steepen. Some deposition in pools.	12	30-50% affected. Debris and scour at obstructions, constrictions and bends. Some filling of pools.	12	30-50% affected. Debris and scour at obstructions, constrictions and bends. Some filling of pools.	18	More than 50% of the bottom in a state of flux or change nearly yearlong.	24	More than 50% of the bottom in a state of flux or change nearly yearlong.	
15	Aquatic Vegetation	Abundant growth moss-like, dark green perennial. In swift water, too.	1	Common. Algae forms in low velocity and pool areas. Moss here, too.	2	Present but spotty, mostly in backwater. Seasonal algae growth makes rocks slick.	2	Present but spotty, mostly in backwater. Seasonal algae growth makes rocks slick.	3	Perennial types scarce or absent. Yellow-green, short term bloom may be present.	4	Perennial types scarce or absent. Yellow-green, short term bloom may be present.		
			Excellent Total =			Good Total =			Fair Total =			Poor Total =		

Stream Type	A1	A2	A3	A4	A5	A6	B1	B2	B3	B4	B5	B6	C1	C2	C3	C4	C5	C6	D3	D4	D5	D6	
Good (Stable)	38-43	38-43	54-90	60-95	60-95	50-80	38-45	38-45	40-60	40-64	48-68	40-60	38-50	38-50	60-85	70-90	80-85	85-107	85-107	85-107	85-107	85-107	67-98
Fair (Mod. Unstable)	44-47	44-47	91-129	96-132	96-142	81-110	46-58	46-58	61-78	65-84	69-88	61-78	51-61	51-61	86-105	91-110	91-110	96-105	108-132	108-132	108-132	108-132	99-125
Poor (Unstable)	48+	48+	130+	133+	143+	111+	59+	59+	79+	85+	89+	79+	62+	62+	106+	111+	111+	106+	133+	133+	133+	133+	126+
Stream Type	DA3	DA4	DA5	DA6	E3	E4	E5	E6	F1	F2	F3	F4	F5	F6	G1	G2	G3	G4	G5	G6	G6	G6	G6
Good (Stable)	40-63	40-63	40-63	40-63	50-75	50-75	40-63	40-63	60-85	80-85	85-110	85-110	90-115	80-95	40-60	40-60	85-107	85-107	90-112	85-107	85-107	85-107	85-107
Fair (Mod. Unstable)	64-86	64-86	64-86	64-86	76-96	76-96	76-96	64-86	86-105	86-105	111-125	111-125	116-130	96-110	61-78	61-78	108-120	108-120	113-125	108-120	108-120	108-120	108-120
Poor (Unstable)	87+	87+	87+	87+	97+	97+	97+	87+	106+	106+	126+	126+	131+	111+	79+	79+	121+	121+	126+	126+	126+	126+	126+

* Rating should be adjusted to Potential Stream Type, not existing.

Riverby Ranch Streams
Channel Stability Rating System

Reach: _____

Rapid Assessment Stream Stability Rating

Excellent
 Good
 Fair
 Poor

Field Data Point	To	Station	From

Extrapolated Stations	
To	Reasoning

Classification Basis Evaluation Category	Excellent (9-10)		Good (6-8)		Fair (3-5)		Poor (0-2)	
	Little to no evidence of bank sloughing, slumping, or failure. (< 10%)	Banks comprised of highly resistant tree/plant/soil material.	Infrequent evidence of bank sloughing, slumping, or failure. Mostly healed over. (10-29.9%)	Banks comprised of moderately resistant tree/plant/soil material	Recent evidence of bank sloughing, slumping, or failure. High potential during flood events. (30-50%)	Banks comprised of highly erodible tree/plant/soil material and material is compromised.	High evidence of bank sloughing, slumping, or failure. (>50%)	Banks comprised of highly erodible tree/plant/soil material and material is severely compromised.
Bank Root Zone	Abundant cover (>70%) 3H:1V or flatter	Mix of point bars and few side bars.	Moderate cover (40-69.9%) 2H:1V - 3H:1V	Infrequent cover (10-39.9%) 1H:1V - 2H:1V	Little to no cover (<10%) 1H:1V or steeper	Stream branching with mid-channel bars and islands or no depositional features.	Extensive amount of manmade channel alteration.	
Vegetative Bank Cover	Point bars small and stable, well vegetated and/or armored with little or no fresh sand.	Infrequent amount of manmade channel alteration.						
Sediment Transport								
Channel Alteration								
Total	0	0	0	0	0	0	0	0

Description: _____

Score	Rapid Assessment Stream Stability Rating
51 - 60	Excellent Condition
37 - 50	Good Condition
20 - 36	Fair Condition
< 20	Poor Condition

Total Score **0**

Attachment B

October 2015 RGA Workshop Attendees

RGA Workshop Attendees List – October 13, 2015

1. USACE
 - a. Andy Comer
 - b. Ed Parisotto

2. USEPA
 - a. Maria Martinez
 - b. Keith Hayden
 - c. Alison Kitto

3. USFWS
 - a. Sid Putter

4. TPWD
 - a. Tom Heger
 - b. Ryan McGillicuddy

5. TCEQ
 - a. Peter Schaffer

6. Solv
 - a. Leon Kolankiewicz

7. NTMWD
 - a. Robert McCarthy
 - b. Ashley Burt

8. FNI
 - a. Simone Kiel
 - b. Steve Watters
 - c. David Coffman
 - d. Stephanie Coffman
 - e. Velita Cardenas
 - f. Michael Votaw
 - g. Randall Howard

9. Lloyd Gosselink
 - a. Sara Thornton

10. Baylor University
 - a. Dr. Peter Allen

Attachment C

Email: LBRC RGA “ground truthing” of data

From: Robert McCarthy
To: Mike Rickman; Billy George; Sara Thornton; Steve Watters; Michael Votaw; Randall Howard; Simone Kiel
Subject: Fwd: LBCR RGA "ground truthing" of data
Date: Monday, December 07, 2015 10:42:07 AM
Attachments: RGA_2015.pdf
RGA_2015_DataPoints_20151204.zip
FW LBCR RGA ground truthing of data (UNCLASSIFIED).msg

Fyi

RM:
Sent via the Samsung GALAXY S5

----- Original message -----

From: "Parisotto, Edward SWT" <Edward.Parisotto@usace.army.mil>
Date: 12/7/2015 9:00 AM (GMT-06:00)
To: "Crawford, Dorothy" <Crawford.Dorothy@epa.gov>, "Kitto, Alison" <Kitto.Alison@epa.gov>, "Hayden, Keith" <Hayden.Keith@epa.gov>, "sidney_puder@fws.gov" <sidney_puder@fws.gov>, 'Ryan McGillicuddy' <Ryan.McGillicuddy@tpwd.texas.gov>, 'Tom Heger' <Tom.Heger@tpwd.texas.gov>, 'Peter Schaefer' <peter.schaefer@tceq.texas.gov>, "robertpotts@fs.fed.us" <robertpotts@fs.fed.us>, 'H M Williams' <hwilliams@sfasu.edu>, "Commer, Andrew SWT" <Andrew.Commer@usace.army.mil>, Robert McCarthy <rmccarthy@NTMWD.COM>, 'Leon Kolankiewicz' <Leon.Kolankiewicz@solvllc.com>, "Hoffmann, Robert SWT" <Robert.B.Hoffmann@usace.army.mil>, "Poulos, Lauren" <poulos.lauren@epa.gov>
Subject: FW: LBCR RGA "ground truthing" of data

Team,

Please reference my November 13th email regarding RGA "truthing". The Corps received valuable comments from some of you and appreciate the time you have taken to provide that input. The Corps has finalized the required additional field work with the applicant.

Attached is a map and data points that the applicant is required to assess utilizing the same RGA method used previously for this project. The field work is tentatively scheduled for the week of 11 January 2016. Field contacts numbers are Michael Votaw, 817-676-3610 or Steve Watters, 817-706-5733.

I will still be the POC for coordination if you plan on monitoring the field work OR schedule changes need to be made (due to weather). If for some reason I am not available, feel free to contact Robert McCarthy at 469-626-4635.

I want to thank each of you again for all of you time and assistance with the evaluation of this field work.

Respectfully,
Ed

Ed Parisotto
Supervisory Regulatory Project Manager
Tulsa District U.S. Army Corps of Engineers
(918) 669-7549 / Fax: (918) 669-4306
<http://www.swt.usace.army.mil/Missions/Regulatory.aspx>
You are invited to complete our Regulatory Service Survey at:

http://corpsmapu.usace.army.mil/cm_apex/f?p=136:4:0

-----Original Message-----

From: Robert McCarthy [mailto:rmccarthy@NTMWD.COM]

Sent: Friday, December 04, 2015 3:42 PM

To: Parisotto, Edward SWT <Edward.Parisotto@usace.army.mil>

Cc: spw@freese.com; Mike Rickman <mrickman@NTMWD.COM>; Billy George <bgeorge@NTMWD.COM>; mpv@freese.com

Subject: [EXTERNAL] LBCR RGA "ground truthing" of data

Ed,

Please see attached a revised RGA "ground truthing" map (and associated shapefiles) on which we relocated the following stream assessment points in response to EPA's November 20, 2015 comment.

- Relocated site TC01 to Stillhouse Branch and renamed it SB01.

While reviewing the stream assessment site placement on Timber Creek, it became apparent that the site that had been labeled SB01 (in the November 2, 2015 email) was actually on an inactive, historic channel of Timber Creek. The name of the point was changed to TC01 and the point was moved northeast, out of the USACE proposed 2015 RGA ground truthing site box, onto the active channel of Timber Creek, which is a previously straightened reach.

With regard to schedule, we are tentatively planning to conduct the RGA ground truthing field study during the week of January 11, 2016. This field schedule is dependent on USACE concurrence with our proposed stream assessment locations as well as weather/field conditions. We'll firm up the field logistics as we get closer to January 11.

Please let me know if you have any questions.

Robert McCarthy
Permit Manager
North Texas Municipal Water District
505 E. Brown St.
P.O. Box 2408
Wylie, Texas 75098
Telephone (469) 626-4633
Email: rmccarthy@ntmwd.com



Innovative approaches...practical results...outstanding service



Proposed Lower Bois d'Arc Creek Reservoir
Fannin County, Texas

Instream Flow Study

May 2010

prepared for:
North Texas Municipal Water District

prepared by:
Freese and Nichols, Inc.



Proposed Lower Bois
d'Arc Creek Reservoir
Fannin County, Texas



**INSTREAM FLOW
STUDY**

May 2010

FREESE AND NICHOLS, INC.
TEXAS REGISTERED
ENGINEERING FIRM
F-2144

Steve Watters, PWS, Hydrologist

Randall Howard, Biologist

Stephanie Capello, Fluvial Geomorphologist

Jon Albright, Hydrologist

Prepared for:

North Texas Municipal Water
District

Prepared by:



Table of Contents

Executive SummaryES-1

1 Introduction 1

 1.1 Purpose of the Instream Flow Study 1

 1.2 Participants in Instream Flow Study 3

 1.3 Definition of a Sound Ecological Environment for Bois d’Arc Creek 4

 1.4 Report Organization 5

2 Background 6

 2.1 Environmental Setting..... 8

 2.1.1 Water Quality and Biology 8

 2.1.2 Physiography..... 8

 2.1.3 Geology and Soils 10

 2.1.4 Climate..... 14

 2.1.5 Land Use 14

 2.1.6 Channelization 14

 2.2 Technical Components of an Instream Flow Study 17

 2.2.1 Hydrology and Hydraulics..... 18

 2.2.2 Fluvial Geomorphology and Physical Processes 18

 2.2.3 Water Quality..... 19

 2.2.4 Biology..... 20

3 Overview of Methods 21

 3.1 Instream Flow Study Plan Development..... 21

 3.2 Instream Flow Study Data Collection and Methods 22

 3.1.1 Hydrology and Hydraulics..... 27

 3.1.2 Fluvial Geomorphology 27

 3.1.3 Water Quality..... 28

 3.1.4 Biology..... 28

 3.2 Data Sources..... 29

 3.2.1 Geomorphic Data 29

- 3.2.2 Hydrologic and Hydraulic Data 30
- 3.2.3 Mapping Data..... 30
- 3.2.4 Water Quality Data 30
- 3.2.5 Biological Data 31
- 4 Baseline Conditions 33
 - 4.1 Hydrology and Hydraulics 33
 - 4.1.1 Gage Records 33
 - 4.1.2 Modeled Flows..... 35
 - 4.2 Fluvial Geomorphology 44
 - 4.2.1 Stream Classification at the Reservoir Site..... 44
 - 4.2.2 Basin-Wide Stream Characterization..... 44
 - 4.2.3 Planform Stability and Erosion..... 53
 - 4.2.4 Sediment Transport Analysis..... 54
 - 4.3 Biology 62
 - 4.3.1 Mesohabitats 63
 - 4.3.2 Macroinvertebrates 64
 - 4.3.3 Fish..... 66
 - 4.3.4 Habitat and Species Associations 73
 - 4.3.5 Fish Index of Biological Integrity..... 73
 - 4.3.6 Habitat Modeling 75
 - 4.4 Water Quality 81
 - 4.4.1 Existing Water Quality 81
 - 4.4.2 Water Quality Modeling 88
 - 4.5 Future Conditions in Bois d’Arc Creek without the Proposed Reservoir 89
- 5 Future Conditions With Reservoir 91
 - 5.1 Potential Impacts of Reservoirs on Streams..... 91
 - 5.1.1 Potential Impacts within the Reservoir Pool..... 91
 - 5.1.2 Potential Downstream Effects..... 98
 - 5.2 Development of Environmental Flow Criteria..... 101
 - 5.2.1 Flow Components 101
 - 5.2.2 Base and Subsistence Flows 102

- 5.2.3 Pulse Flows 106
- 5.3 Expected Downstream Conditions with Proposed Flow Regime 109
 - 5.3.1 Hydrologic Modeling..... 109
 - 5.3.2 Fluvial Geomorphology 116
 - 5.3.3 Water Quality with Proposed Instream Flow Regime 121
- 5.4 Impact on Reservoir Yield 125
- 6 MONITORING AND ADAPTIVE MANAGEMENT 126
 - 6.1 Monitoring..... 126
 - 6.1.1 Water Quality..... 126
 - 6.1.2 Geomorphology 126
 - 6.1.3 Hydrology: 127
 - 6.1.4 Biology..... 127
 - 6.2 Adaptive Management 127

List of Tables

- Table 1.1 Inter-Agency Team 4
- Table 3.1 Field Methods Utilized for the Bois d’Arc Creek Instream Flow Study 26
- Table 3.2 Field Methods Utilized at Each Instream Flow Study Site..... 27
- Table 4.1 Relevant USGS Streamflow Records 33
- Table 4.2 Bois d’Arc Creek Flow Rates and Inundated Area for 1.0-Year to 2.0-Year Storm Events..... 37
- Table 4.3 Bois d’Arc Creek Flow Statistics at FM 1396..... 42
- Table 4.4 River Styles at Study Reaches 48
- Table 4.5 Means, Standard Deviations, and Ranges for Selected Water Features by Mesohabitat..... 64
- Table 4.6 Mussel Species Collected during Instream Flow Study on Bois d’Arc Creek 67
- Table 4.7 Fish Collected During Bois d’Arc Creek Instream Flow Study 69
- Table 4.8 Modeled Habitat Distribution at FM 409..... 76
- Table 4.9 Dissolved Oxygen Criteria by Aquatic Life Use Designation..... 82
- Table 4.10 Summary of Red River Authority Water Quality Data from Bois d’Arc Creek Near Bonham..... 85
- Table 4.11 Summary of NTMWD Bois d’Arc Creek Water Quality Data (June 2007 through December 2008)..... 86
- Table 4.12 Summary of FNI Water Quality Sampling Data (June and July 2009) 88

Table 4.13	Publicly Owned Treatment Works Authorized by TPDES Permit to Discharge in the Bois d’Arc Creek Watershed	89
Table 5.1	USGS Water Quality Data (Temperature and Dissolved Oxygen Concentrations) for Selected North Texas Lakes	96
Table 5.2	Pulse Release Schedule.....	110
Table 5.3	Comparison of Modeled Flow Statistics at FM 409 - Pre-Dam and Post-Dam with Proposed Releases.....	111
Table 5.4	Comparison of Modeled Environmental Flow Components at FM 409 – Pre-Dam and Post-Dam with Proposed Releases.....	114
Table 5.5	Number of Reservoir Spill Days per Year in Simulation	116
Table 5.6	Comparison of Pulse and Overbank Events with Proposed Bypass During 1948 to 1998 Simulation Period	116
Table 5.7	Impact of Environmental Flows on Reservoir Yield	125

List of Figures

Figure 1.1	Study Area	2
Figure 2.1	Location Map.....	7
Figure 2.2	Eco-Regions for Fannin County	9
Figure 2.3	Geology of the Bois d’Arc Creek Watershed	12
Figure 2.4	Soils of the Bois d’Arc Creek Basin	13
Figure 2.5	Mean Annual Precipitation	15
Figure 2.6	Bois d’Arc Creek Historical (1915) Channel Alignment	16
Figure 3.1	Bois d’Arc Creek Instream Flow Study Sites.....	23
Figure 3.2	Transects at Bois d’Arc Creek Study Reach near FM 1396	24
Figure 3.3	Transects at Bois d’Arc Creek Study Reach near FM 409	25
Figure 4.1	Map of Gage Locations.....	34
Figure 4.2	Historical Flow Data for USGS Gage 07332620 - Bois d’Arc Creek at FM 1396.....	36
Figure 4.3	1-Year Inundation Map.....	38
Figure 4.4	1.5-Year Inundation Map.....	39
Figure 4.5	2-Year Inundation Map.....	40
Figure 4.6	RiverWare Model Layout	41
Figure 4.7	Flow-Duration Curve of Modeled FM 1396 Flows.....	43
Figure 4.8	Rapid Geomorphic Assessment Stream Classification within the Reservoir Site.....	46
Figure 4.9	Landscape Units and River Styles for Bois d’Arc Creek	47
Figure 4.10	US 82 Geomorphic Base Map	49
Figure 4.11	FM 2645 Geomorphic Base Map.....	50
Figure 4.12	FM 1396 Geomorphic Base Map.....	51

Figure 4.13	FM 409 Geomorphic Base Map.....	52
Figure 4.14	Planform View of Bois d’Arc Creek North of US 82.....	55
Figure 4.15	Planform View of Bois d’Arc Creek near CR 2645	56
Figure 4.16	Planform View of Bois d’Arc Creek near FM 1396.....	57
Figure 4.17	Planform View of Bois d’Arc Creek near FM 409.....	58
Figure 4.18	Planform View of Bois d’Arc Creek in the USFS.....	59
Figure 4.19	Sediment Rating Curve of the Surface Sediment at FM 1396.....	60
Figure 4.20	Sediment Rating Curve of the Subsurface Sediment at FM 1396	61
Figure 4.21	Sediment Rating Curve of the Surface Sediment at FM 409.....	61
Figure 4.22	Sediment Rating Curve of the Subsurface Sediment at FM 409	62
Figure 4.23	Benthic Macroinvertebrate Trophic Structure at Bois d’Arc Creek Study Sites	65
Figure 4.24	Rapid Bioassessment Results (Upstream to Downstream).....	66
Figure 4.25	Relative Abundance of Fish Taxa by Sample Site, Flow Regime, Mesohabitat, and Season.....	70
Figure 4.26	Bois d’Arc Creek Trophic Structure and Reproductive Guild by Site, Flow Regime, Mesohabitat, and Season	72
Figure 4.27	Reproductive Timing of Dominant Species in Bois d’Arc Creek Compared with Mean Monthly Temperature and Median Monthly Stream Discharge.....	74
Figure 4.28	Fish Index of Biological Integrity (IBI) Results from Bois d’Arc Creek Study Reaches	75
Figure 4.29	Water depth at FM 409 at 3 cfs Stream Flow	77
Figure 4.30	Velocity at FM 409 at 3 cfs Stream flow	78
Figure 4.31	Pool Habitat Suitability Index at FM 409 at 3 cfs Stream Flow.....	79
Figure 4.32	Weighted Usable Area (WUA) versus Simulated Discharges at FM 409	80
Figure 4.33	Water Quality Sampling Site Locations	83
Figure 4.34	Mean Monthly Water Temperature at the USGS FM 1396 Gage (September 2006 through September 2009)	84
Figure 4.35	Daily Mean Dissolved Oxygen vs. Temperature at the USGS FM 1396 Gage (October 2006 through January 2010)	84
Figure 4.36	Daily Mean Dissolved Oxygen vs Flow at the USGS FM 1396 Gage (October 2006 through January 2010)	85
Figure 4.37	Dissolved Oxygen Concentrations at NTMWD Sampling Sites in Bois d’Arc Creek	86
Figure 4.38	Mean Daily Flow in Bois d’Arc Creek at the USGS FM 1396 Gage on the NTMWD Water Sampling Dates.....	87
Figure 5.1	Locations of North Texas Reservoirs Relative to the Proposed Lower Bois d’Arc Creek Reservoir.....	95
Figure 5.2	Modeled Current Velocity and Flow Depth at FM 409 – 3 CFS.....	104
Figure 5.3	Modeled Current Velocity and Flow Depth at FM 409 – 10 CFS.....	105

Figure 5.4 Reproductive Timing of Dominant Species at Bois d’Arc Creek with Mean Monthly Temperature vs. Median Monthly Stream Discharge 106

Figure 5.5 Modeled Current Velocity and Flow Depth at FM 409 – 50 CFS 108

Figure 5.6 RiverWare Model with Lower Bois d’Arc Creek Reservoir 109

Figure 5.7 Comparison of Flow Duration at FM 409 Before and After Dam..... 112

Figure 5.8 Simulated Lower Bois d’Arc Creek Reservoir Storage 114

Figure 5.9 Simulated Coffee Mill Lake Storage 115

Figure 5.10 Simulated Lake Crockett Storage 115

Figure 5.11 Lane’s Balance..... 117

Figure 5.12 Incised Channel Evolution Model. 119

Figure 5.13 Results of the Incipient Motion Analysis Through the FM 409 Study Reach Using Four Different Flows 121

Figure 5.14 Predicted Dissolved Oxygen Concentrations in Bois d’Arc Creek Downstream of the Proposed Reservoir for April through June..... 123

Figure 5.15 Predicted Dissolved Oxygen Concentrations in Bois d’Arc Creek Downstream of the Proposed Reservoir for July through October Proposed Flows 123

Figure 5.16 Predicted Dissolved Oxygen Concentrations in Bois d’Arc Creek Downstream of the Proposed Reservoir for November through March Proposed Flows..... 124

List of Appendices

Appendix A References

Appendix B Hydrology and Hydraulics

Appendix C Geomorphology

Appendix D Biology

Appendix E Water Quality

Appendix F Photography Summary of Study Sites

Appendix G Photography Summary of Field Activities

EXECUTIVE SUMMARY

This report presents the findings and recommendations of the instream flow study on Bois d'Arc Creek in support of permitting activities for the proposed Lower Bois d'Arc Creek Reservoir. The purpose of the study was to characterize the baseline stream conditions of Bois d'Arc Creek within the proposed reservoir site and downstream, develop predictions of conditions within the reservoir pool, and develop a proposed instream flow regime to maintain a sound ecological environment downstream of the proposed dam.

In accordance with the Texas Instream Flow Program, this study evaluated the four technical components that characterize stream conditions: hydrology and hydraulics, fluvial geomorphology, water quality, and aquatic biology. These components were evaluated in the context of the existing and future stream system, and collectively were used to define a sound ecological environment for Bois d'Arc Creek. To achieve a sound ecological environment, the instream flow regime must:

- Provide sufficient stream power to move sediment in the channel while not creating excessive stream bed and bank erosion;
- Support a spectrum of mesohabitats – pools, runs, riffles and structures;
- Provide hydraulic connectivity to support biological communities;
- Maintain existing water quality standards of the stream for High Aquatic Life use;
- Provide seasonally varying flows to support fish reproduction; and
- Maintain or improve existing fish and macroinvertebrate communities and biodiversity as measured by scientific standards.

With the assistance of an Inter-Agency Team (representatives of state and federal agencies), the scope of work for this study was refined and field data were collected over a five-month period from March 2009 through July 2009. In addition to these field data, literature reviews, data from previous studies (including studies for this project and other independent studies), and available resource data were used to define the stream baseline conditions and evaluate the proposed instream flow regime.

Bois d'Arc Creek is a highly channelized stream system. This has been identified and documented in previous studies as well as in this instream flow study. The altered nature of the stream system is important because the channelization plays a significant role in the current behavior and processes occurring in the stream system. The straightened and channelized sections of Bois d'Arc Creek contribute to the flashy nature of the creek, substantial erosion of the stream bed and banks, lack of habitat diversity in channelized sections, and minimal lateral migration of the stream.

The frequent large flow pulses that occur in response to rain events in the watershed are contributing to continuing erosion, including channel downcutting and bank mass failures. This

results in negative impacts to aquatic habitats by mass wasting and high current velocities that scour established habitats. This study found that large flows are not necessary to move sediment along the creek bed. The sediment transport analyses determined that flows less than 1 cfs can transport fine sediments and that gravel transport begins at 25 cfs.

While the Texas Commission on Environmental Quality (TCEQ) classifies Bois d'Arc Creek as perennial, this instream flow study documented extended periods with little to no flows. During these dry times, the aquatic species must migrate from runs and riffle areas and seek refuge in deeper pools. There were 42 species of fish collected and identified as part of this study. Most of these species are generalist species, with red shiner accounting for 50 percent of the relative abundance and longear sunfish accounting for 13.7 percent. Generalist species are more adapted for survival than obligate stream species in the widely varying hydraulic conditions documented in Bois d'Arc Creek, with flows ranging from 0 to greater than 10,000 cfs. The quality of the existing fish communities, as measured by the fish Index of Biological Integrity (IBI), was found to be generally in the High Aquatic Life Use category. Aquatic habitats are dominated by pools (70 to 80% of the weighted useable area) and runs (14 to 28% WUA). Habitat modeling found that flows as low as 2 to 3 cfs provide connectivity between the mesohabitats in the modeled reaches. When evaluating the relationship of habitats with the identified species, there are no statistically significant species-habitat associations. These findings are consistent with the stream hydraulics and the types of species identified in the creek.

Of the fish species identified, most reproduce from spring to early summer. The reproductive cues appear to be largely temperature dependent. The conditions of Bois d'Arc Creek tend to favor the generalist species. The little to no flow conditions observed during the summer months are unfavorable spawning conditions for fluvial specialists.

A total of 2,621 macroinvertebrates, consisting of 103 identified genus and 46 families, were collected as part of this study. The macroinvertebrates were used to define the trophic structure of Bois d'Arc Creek and assess the aquatic life use. Using the Rapid Bioassessment Protocol, the analyses found the overall biological integrity of the macroinvertebrate community at the instream flow sampling sites to be at the higher end of the intermediate range. This is consistent with previous studies on Bois d'Arc Creek and the nearby North Sulphur River.

Water quality data collected during this study and from others (USGS, TCEQ, Red River Authority) is consistent with the High Aquatic Use classification of the stream. Measured dissolved oxygen concentrations generally ranged between 5.4 and 10.7 mg/L at all sites but the U.S. 82 site. The low dissolved oxygen concentrations at this site during limited sampling by the Red River Authority were attributed to warm temperatures and very low current velocity due to a log jam located upstream. Water quality does not appear to be a limiting factor for aquatic life in Bois d'Arc Creek. The observed data indicate that there are sufficient dissolved oxygen concentrations in the creek provided there is any flow in the stream. However, even during

extreme drought conditions, there apparently is adequate dissolved oxygen in pools to sustain aquatic life.

Hydrologic and geomorphic analyses indicate that the Bois d'Arc Creek is currently in disequilibrium. Downcutting and streambank erosion have increased, and lateral migration of the stream (i.e., meander creation) has slowed. Channelization has increased the "flashy" nature of flows in the watershed, with rapid rise and fall in flow in response to rainfall events. This likely has reduced base flows in the watershed as well. Instream habitats continually vary, as high flows scour gravel bars and dislodge large woody debris or low flows reduce connectivity along the stream. The frequency of extreme flow events, both high and low, has resulted in an environment that favors generalist species. Although water quality in the watershed is generally good, Bois d'Arc Creek is not able to support a large variety of aquatic life because the relatively few habitat features in the watershed are frequently washed away by high flow events. The apparent lack of reliable subsistence or baseflow hydrology from year to year may also be a limiting factor for fish and other aquatic species. With no changes in the watershed, Bois d'Arc Creek is expected to continue to downcut and erode, enlarging the existing channel. This will further reduce longitudinal connectivity at low flows and continue to constrain aquatic species to specific habitats that contain water (i.e., pools).

To provide a sound ecological environment in Bois d'Arc Creek, it is necessary to reduce the frequent highly erosive flows and provide sufficient flows to maintain water quality, provide connectivity between habitats, and foster aquatic species reproduction and habitat maintenance. Consistent with the Texas Instream Flow Program, it is proposed that the following instream flow regime as measured at the USGS gage located at FM 409 would provide a sound ecological environment for Bois d'Arc Creek downstream of the proposed reservoir:

- **Subsistence flow: 1 cfs** . This would provide flow to maintain water quality during extreme drought. Water would be released through the dam when the Lower Bois d'Arc Creek Reservoir is less than 40 percent full. Based on modeling studies, this occurs 9 percent of the time.
- **Base Flow (July to March): 3 cfs**. This flow would provide connectivity of mesohabitats and is capable of moving sediment through the channel. Releases of 3 cfs are proposed to occur from July through March.
- **Base Flow (April to June): 10 cfs**. These higher base flows are proposed during the primary spawning months of the dominant fish species to encourage and support reproductive activities.
- **Pulse Flow: 50 cfs**. It is proposed that two deliberate pulse flows would be released annually if such flows do not occur naturally. One pulse flow of 50 cfs would be released on June 1 if one did not occur in the previous April or May. Another pulse release would occur on October 1 if one did not occur in the previous September. These pulse releases

would provide the necessary stream power to move larger sediment particles (gravel) and maintain habitats.

Flows greater than 50 cfs would not be released from the reservoir to minimize erosional processes, channel downcutting and habitat destruction. There still would be naturally occurring larger flow events associated with runoff from the watershed downstream of the dam, spills from the Lower Bois d'Arc Creek Reservoir, and spills from existing downstream reservoirs (Coffee Mill and Crockett Lake). This reduction in the number and volume of large erosive flow events would also allow vegetation to become established along the stream banks and help restore the downstream riparian corridor.

The proposed flow regime is expected to allow the establishment of and preservation of relatively long-lived habitats while less frequently occurring larger events would perform the maintenance that is needed from time to time for habitat sustainability.

With the dam in place and the proposed environmental flow releases, there would be

- Higher median flows during low flow periods;
- Fewer erosive high flow events;
- Improved water quality during typically low flow summer months;
- Sustainable aquatic habitats;
- Increased stability of stream banks; and
- Increased potential for aquatic diversity and migration with higher median low flows.

54. Description of Project, including a bulleted list of project elements/components, and alternatives that were considered.

- **Please see Section 1.1 of the DEIS for a description of the LBCR Project. This section begins on Page 1-1 of the DEIS (Page 48 of 602 of the PDF File Titled “LBCR Revised DEIS 3-21-17 PRINT READY”).**
- **The 84" Pipeline from the LWTP to Hwy 5 Pump Station (McKinney No. 4) extends from the proposed LWTP site to the NTMWD’s 84-inch North McKinney Phase 3 Pipeline located just east of State Highway 5 in north McKinney, Texas. The NTMWD will be acquiring sufficient easement for the proposed pipeline to install a future parallel 84-inch pipeline as the capacity of the LWTP is increased.**
- **It is important to document how the NTMWD has organized the LBCR Program. There is an overall program management function that is staffed by NTMWD personnel as well as outsourced program management consultants. The design and execution of the projects has been organized under five Construction Managers at Risk (CMARs). On the file titled “FY 17 SWIFT Application Project Table.PDF” there is references to six categories the NTMWD projects fall within. These are; (1) Program, (2) CMAR 1, (3) CMAR 2, (4) CMAR 3, (5) CMAR 4, and (6) CMAR 5. A description of each of these categories is below;**
 - **Program – These are items specifically related to permitting, archeological, or program management functions.**
 - **CMAR 1 – These are the design and construction projects as well as property acquisition related to the Dam, Terminal Storage Reservoir, and Reservoir Clearing.**
 - **CMAR 2- These are the design and construction projects as well as property acquisition related to the mitigation.**
 - **CMAR 3 - These are the design and construction projects as well as property acquisition related to the water treatment plant, raw water pump station, and high service pump station.**
 - **CMAR 4 - These are the design and construction projects as well as property acquisition related to the road improvements and boat ramps.**
 - **CMAR 5 - These are the design and construction projects as well as property acquisition related to the pipelines.**
- **Due to the multi-project nature of the LBCR Program and the fact that many of the components are in various stages of planning and design, there is not a single engineering feasibility document that can be provided. The file titled “FY 17 SWIFT Application Project Table.PDF” summarizes by project the supporting documentation file that the NTMWD is submitting in support of the SWIFT application.**

FY17 SWIFT Application Project Table -FUNDING (\$M)

Approx. Award Date	Reference Number	Contract Description	Typ	NTMWD Project Number	Assigned CMAR	TWDB Funding Category	Current Estimated Cost \$M	Escalation %/age	Total Estimated Cost \$M	Description	Supporting Documents Provided	
LOWER BOIS D'ARC CREEK RESERVIOR (LBCR)												
02/2017	1	LBCR - Additional Archaeological Services	6-Perm	101-0237-11	Program	Planning	\$ 0.640000	0%	\$ 0.640000	Archeological services for mitigation of sites	Reference Section 3.14 of DEIS (PDF Page 297 of 602 for discussion on archeological efforts	
02/2017	2	LBCR - Fannin County Rd and Bridge Imp - Final Design	1-Eng	101-0435-16	4	Design	\$ 1.089000	0%	\$ 1.089000	Final design of country road improvements to deconflict with reservoir	Reference Final Transportation Report 5-3-11.PDF file	
04/2017	3	LBCR - Payment to Bois d'Arc MUD	11-Cnstr		Program	Design	\$ 2.600000	0%	\$ 2.600000	Agreement to local water district to design and construct improvements to tr	N/A. Can provide future signed agreement	
04/2017	4	LBCR - EIS Additional Services	1-Eng	101-0192-09	Program	Planning	\$ 0.800000	0%	\$ 0.800000	Additional permitting professional services	N/A. Can provide contract at future date.	
04/2017	5	LBCR - 90" Pipeline Section A - Final Design	1-Eng	101-0424-16	5	Design	\$ 2.500000	0%	\$ 2.500000	Final design of 90" PL scheduled for May 17 start.	Reference LBCR RWPL Final PDR.PDF	
04/2017	6	LBCR - 90" Pipeline Section B - Final Design	1-Eng	101-0424-16	5	Design	\$ 2.500000	0%	\$ 2.500000	Final design of 90" PL scheduled for May 17 start.	Reference LBCR RWPL Final PDR.PDF	
04/2017	7	LBCR - 90" Pipeline Section C - Final Design	1-Eng	101-0424-16	5	Design	\$ 2.500000	0%	\$ 2.500000	Final design of 90" PL scheduled for May 17 start.	Reference LBCR RWPL Final PDR.PDF	
04/2017	8	LBCR - Conflict Relocations - Design	1-Eng		Program	Design	\$ 2.500000	0%	\$ 2.500000	Agreements with franchise utilities to remove conflicts	Reference LBCR Conflict Map.PDF	
06/2017	9	LBCR Additional Basic Engr/Planning Phase III B - Permitting	6-Perm	101-0351-14	Program	Planning	\$ 0.400000	0%	\$ 0.400000	Additional permitting professional services	N/A. Can provide contract at future date.	
07/2017	10	LBCR - Addtl Legal Services - Legal	5-Legal		Program	Planning	\$ 0.500000	0%	\$ 0.500000	Additional legal services	N/A. Can provide contract at future date.	
10/2017	11	LBCR - Mitigation - Additional Design	1-Eng	101-0366-14	2	Design	\$ 1.000000	0%	\$ 1.000000	Additional design for additional area based on most current mitigation plan.	Reference Section 1.8 of DEIS (PDF Page 79 of 602)	
10/2017	12	LBCR Program Management - Lake Operations Plan and Engineering/Disaster Response Plan	1-Eng	101-0374-14	Program	Planning	\$ 0.567000	0%	\$ 0.567000	Reservoir operations planning.	N/A. Can provide contract at future date.	
10/2017	13	LBCR - Additional Program Management - Design	1-Eng	101-0374-14	Program	Design	\$ 2.300000	0%	\$ 2.300000	Annual renewal of LBCR Program Management services	N/A. Can provide contract at future date.	
10/2017	14	LBCR Program Management - Shoreline Management Plan	1-Eng	101-0374-14	Program	Planning	\$ 0.300000	0%	\$ 0.300000	Reservoir operations planning.	N/A. Can provide contract at future date.	
02/2018	15	LBCR - Acquisition of Property (Includes Surveying & Legal) - Property*	4-Prop	101-0344-13	Program	Acquisition	\$ 8.120000	3%	\$ 8.363600	Future funding for final property acquisition in footprint of reservoir.	N/A.	
02/2018	16	LBCR - Acquisition of Property (Includes Surveying & Legal) - Property*	4-Prop	101-0344-13	Program	Acquisition	\$ 3.460000	3%	\$ 3.563800	Future funding for final property acquisition in footprint of reservoir.	N/A.	
02/2018	17	LBCR - Archeology Support and Permitting	6-Perm	101-0237-11	Program	Planning	\$ 6.750000	3%	\$ 6.952500	Archeological services for mitigation of sites	Reference Section 3.14 of DEIS (PDF Page 297 of 602 for discussion on archeological efforts	
04/2018	18	LBCR 90" Pipeline - Pipeline Right of Way (ROW) - Property*	4-Prop	101-0424-16	Program	Acquisition	\$ 7.080000	3%	\$ 7.292400	Future funding for 90-inch pipeline easements.	Reference LBCR RWPL Final PDR.PDF	
04/2018	19	LBCR - County Roads Relocation - Construction	11-Cnstr	101-0435-16	4	Construction	\$ 14.200000	3%	\$ 14.626000	Construction of country road improvements to deconflict with reservoir	Reference Final Transportation Report 5-3-11.PDF file	
04/2018	20	LBCR Dam - Construction*	11-Cnstr	101-0344-13	1	Construction	\$ 161.000000	3%	\$ 165.830000	Construction of LBCR Dam	Reference Final Dam PDR.PDF	
04/2018	21	LBCR - Conflict Relocations (Utilities, MUD CNN, North WTP Dam, & Lake Bonham Protection) - Construction*	11-Cnstr		Program	Construction	\$ 20.100000	3%	\$ 20.703000	Agreements with franchise utilities to remove conflicts	Reference LBCR Conflict Map.PDF	
04/2018	22	LBCR - FM 897 Relocation - Construction	11-Cnstr	101-0383-15	4	Construction	\$ 44.800000	3%	\$ 46.144000	Construction of new FM 897.	Reference Final Transportation Report 5-3-11.PDF file	
04/2018	23	LBCR - Riverby - Mitigation - Construction	11-Cnstr	101-0366-14	2	Construction	\$ 81.400000	3%	\$ 83.842000	Construction of mitigation on Riverby Ranch.	Reference Section 1.8 of DEIS (PDF Page 79 of 602)	
04/2018	24	LBCR - Riverby - Mitigation - Fence Construction	11-Cnstr	101-0366-14	2	Construction	\$ 1.130000	3%	\$ 1.163900	Construction of mitigation on Riverby Ranch.	Reference Section 1.8 of DEIS (PDF Page 79 of 602)	
04/2018	25	LBCR PS - Electrical Power Transmission - Construction*	11-Cnstr		Program	Construction	\$ 11.700000	3%	\$ 12.051000	Payment to construct transmission power to support RWPS	Reference LBCR Project Location Map.PDF showing locations	
04/2018	26	LBCR Clearing - Construction & Inspection	11-Cnstr	101-0344-13	1	Construction	\$ 5.755000	3%	\$ 5.927650	Clearing of reservoir footprint.	Reference Appendix T of the DEIS for the clearing plan.	
05/2018	27	LBCR Dam - Materials Testing - Construction*	11-Cnstr	101-0344-13	1	Construction	\$ 2.060000	3%	\$ 2.121800	Material testing for dam construction	Reference Final Dam PDR.PDF	
05/2018	28	LBCR - Conflict Relocations (Utilities, MUD CNN, North WTP Dam, & Lake Bonham Protection) - Inspection*	10-Insp		Program	Construction	\$ 0.164000	3%	\$ 0.168920	Inspection of franchise utility relocation	Reference LBCR Conflict Map.PDF	
05/2018	29	LBCR - County Roads Relocation-Materials Testing - Construction	11-Cnstr	101-0435-16	4	Construction	\$ 0.530000	3%	\$ 0.545900	Material testing for county road construction	Reference Final Transportation Report 5-3-11.PDF file	
05/2018	30	LBCR - FM 897 Relocation - Materials Testing - Construction	11-Cnstr	101-0383-15	4	Construction	\$ 2.120000	3%	\$ 2.183600	Material testing for FM 897 construction	Reference Final Transportation Report 5-3-11.PDF file	
05/2018	31	LBCR - Mitigation - Inspection*	10-Insp	101-0366-14	2	Construction	\$ 1.200000	3%	\$ 1.236000	Inspection services for mitigation construction	Reference Section 1.8 of DEIS (PDF Page 79 of 602)	
05/2018	32	LBCR Dam - Inspection*	10-Insp	101-0344-13	1	Construction	\$ 4.430000	3%	\$ 4.562900	Inspection services for dam construction	Reference Final Dam PDR.PDF	
05/2018	33	LBCR - County Roads Relocation - Inspection	10-Insp	101-0435-16	4	Construction	\$ 0.279000	3%	\$ 0.287370	Inspection services for county road construction	Reference Final Transportation Report 5-3-11.PDF file	
06/2018	34	LBCR - Lake Office - Design	1-Eng		Program	Design	\$ 0.206000	3%	\$ 0.212180	Future funding for design of NTMWD's admin. Office at reservoir	N/A	
07/2018	35	LBCR - 90" Pipeline and 84" Treated Water Line - CMAR Procurement Svcs - Construction	11-Cnstr	101-0424-16	5	Construction	\$ 0.250000	3%	\$ 0.257500	Funding for the procurement services that are part of the CMAR 5 (Pipelines	Reference CMAR 5 - Pipelines (Garney Construction) contract	
09/2018	36	LBCR - Boat Ramps and Parks - Design	1-Eng	101-0436-16	4	Design	\$ 0.546000	3%	\$ 0.562380	Future funding for the design of three recreational boat ramps	Reference Figure 22 of the LBCR Comprehensive Plan.PDF (Page 88)	
10/2018	37	LBCR - Archeology During Construction	11-Cnstr	101-0237-11	Program	Planning	\$ 1.000000	3%	\$ 1.030000	Future funding for archeology support during construction	Reference Section 3.14 of DEIS (PDF Page 297 of 602 for discussion on archeological efforts	
10/2018	38	LBCR - Additional Program Management - Design	1-Eng	101-0374-14	Program	Design	\$ 2.060000	3%	\$ 2.121800	Annual renewal of LBCR Program Management services	N/A. Can provide contract at future date.	
11/2018	39	LBCR - TSR - Procurement & Construction	11-Cnstr	101-0344-13	1	Construction	\$ 0.153000	3%	\$ 0.157590	Funding for the construction phase/procurement services that are part of the	Reference CMAR 1 - Dam and TSR (Archer Western) contract	
11/2018	40	LBCR PS - Discharge Pipeline - Construction*	11-Cnstr	101-0424-16	5	Construction	\$ 2.950000	3%	\$ 3.038500	Construction of the portion of the 90" pipeline that is on the Dam site	Reference LBCR RWPL Final PDR.PDF	
11/2018	41	LBCR PS - Construction*	11-Cnstr	101-0358-14	3	Construction	\$ 65.800000	3%	\$ 67.740000	Construction of the LBCR Raw Water Pump Station	Reference RWPS Prelim Design Report (Pump Station PDR_DRAFT.PDF)	
12/2018	42	LBCR PS - Inspection*	10-Insp	101-0358-14	3	Construction	\$ 0.356000	6%	\$ 0.377360	Construction inspection services for the raw water pump station	Reference RWPS Prelim Design Report (Pump Station PDR_DRAFT.PDF)	
02/2019	43	LBCR 90" Pipeline - Construction*	11-Cnstr	101-0424-16	5	Construction	\$ 176.000000	6%	\$ 186.560000	Construction of the main 90-inch raw water transmission pipeline	Reference LBCR RWPL Final PDR.PDF	
03/2019	44	LBCR - Lake Office - Construction	11-Cnstr		Program	Construction	\$ 2.060000	6%	\$ 2.183600	Future funding for construction of NTMWD's admin. Office at reservoir	N/A	
03/2019	45	LBCR 90" Pipeline - Inspection*	10-Insp	101-0424-16	5	Construction	\$ 0.906000	6%	\$ 0.960360	Construction inspection services for the raw water pipeline	Reference LBCR RWPL Final PDR.PDF	
03/2019	46	LBCR 90" Pipeline - Materials Testing - Construction	11-Cnstr	101-0424-16	5	Construction	\$ 1.060000	6%	\$ 1.123600	Material testing during construction of the raw water pipeline	Reference LBCR RWPL Final PDR.PDF	
06/2019	47	Leonard WTP Terminal Storage Reservoir - Phase I (210 MG) - Construction	Table Q23	11-Cnstr	101-0344-13	1	Construction	\$ 29.400000	6%	\$ 31.164000	Construction of the Terminal Storage Reservoir in Leonard	Reference LBCR TSR Site Analysis 01-23-14.PDF
07/2019	48	Leonard WTP Terminal Storage Reservoir - Phase I (210 MG) - Inspection	Table Q23	10-Insp	101-0344-13	1	Construction	\$ 0.294000	6%	\$ 0.311640	Construction inspection of the Terminal Storage Reservoir in Leonard	Reference LBCR TSR Site Analysis 01-23-14.PDF
07/2019	49	Leonard WTP Terminal Storage Reservoir - Phase I (210 MG) - Materials Testing - Construction	Table Q23	11-Cnstr	101-0344-13	1	Construction	\$ 1.060000	6%	\$ 1.123600	Construction material testing of the Terminal Storage Reservoir in Leonard	Reference LBCR TSR Site Analysis 01-23-14.PDF
09/2019	50	LBCR - Boat Ramps and Parks - Construction	11-Cnstr	101-0436-16	4	Construction	\$ 3.760000	6%	\$ 3.985600	Construction of the boat ramps in county comprehensive plan	Reference Figure 22 of the LBCR Comprehensive Plan.PDF (Page 88)	
10/2019	51	LBCR - Boat Ramps and Parks - Inspection	10-Insp	101-0436-16	4	Construction	\$ 0.037000	6%	\$ 0.039220	Construction inspection of the boat ramps in county comprehensive plan	Reference Figure 22 of the LBCR Comprehensive Plan.PDF (Page 88)	
10/2019	52	LBCR - Additional Program Management - Design	1-Eng	101-0374-14	Program	Construction	\$ 1.850000	6%	\$ 1.961000	Annual renewal of LBCR Program Management services	N/A. Can provide contract at future date.	
06/2020	53	LBCR - Final Riverby, etc. - Replanting and Monitoring - Mitigation*	7-Perm/Mit	101-0366-14	2	Construction	\$ 0.109000	9%	\$ 0.118810	Replanting and monitoring efforts at the Riverby mitigation area	Reference Section 1.8 of DEIS (PDF Page 79 of 602)	
06/2021	55	LBCR - Final Riverby, etc. - Replanting and Monitoring - Mitigation*	7-Perm/Mit	101-0366-14	2	Construction	\$ 0.109000	12%	\$ 0.122080	Replanting and monitoring efforts at the Riverby mitigation area	Reference Section 1.8 of DEIS (PDF Page 79 of 602)	
06/2022	57	LBCR - Final Riverby, etc. - Replanting and Monitoring - Mitigation*	7-Perm/Mit	101-0366-14	2	Construction	\$ 0.109000	15%	\$ 0.125350	Replanting and monitoring efforts at the Riverby mitigation area	Reference Section 1.8 of DEIS (PDF Page 79 of 602)	
TOTAL LOWER BOIS D'ARC CREEK RESERVIOR (LBCR)							\$ 686.549000		\$ 713.072510			
TREATMENT & TREATED WATER DISTRIBUTION												
02/2017	58	70 MGD Leonard WTP Site Phase I - Final Design	1-Eng	101-0384-15	3	Design	\$ 16.371000	0%	\$ 16.371000	Final design of the Leonard WTP	Reference WTP Prelim Design Technical Memorandums	
07/2017	59	90 MGD Leonard Water Treatment Plant HSPS - Final Design	1-Eng	101-0428-16	3	Design	\$ 4.430000	0%	\$ 4.430000	Final design of the High Service Pump Station at Leonard	N/A. Preliminary design underway. PDR to follow	
11/2017	60	Leonard WTP Terminal Storage Reservoir - Phase I (210 MG) - Design	1-Eng	101-0344-13	1	Design	\$ 1.742000	0%	\$ 1.742000	Final design of the TSR at Leonard	Reference LBCR TSR Site Analysis 01-23-14.PDF	
04/2018	61	84" PL from Leonard WTP to Hwy 5 Pump Station (McKinney No. 4) - Final Design	1-Eng	101-0425-16	5	Design	\$ 7.350000	3%	\$ 7.570500	Final design of the treated water pipeline	Reference prelim mapping (TWPL Align Alternates.PDF)	
04/2018	62	Leonard WTP Electrical/Transmission Line - Construction	11-Cnstr		Program	Construction	\$ 20.400000	3%	\$ 21.012000	Payment to construct transmission power to support Leonard WTP	Reference LBCR Project Location Map.PDF showing locations	
05/2018	63	Leonard WTP Electrical/Transmission Line - Inspection	10-Insp		Program	Construction	\$ 0.402000	3%	\$ 0.414060	Payment to inspect transmission power to support Leonard WTP	Reference LBCR Project Location Map.PDF showing locations	
09/2018	64	84" PL from Leonard WTP to Hwy 5 Pump Station (McKinney No. 4) - Property	4-Prop	101-0425-16	5	Acquisition	\$ 4.810000	3%	\$ 4.954300	Easment acquisition for the treated water pipeline	Reference prelim mapping (TWPL Align Alternates.PDF)	
12/2018	65	70 MGD Leonard WTP Site Phase I - Construction	11-Cnstr	101-0384-15	3	Construction	\$ 211.000000	6%	\$ 223.660000	Construction of the Leonard WTP	Reference WTP Prelim Design Technical Memorandums	
01/2019	66	70 MGD Leonard WTP Site Phase I - Inspection	10-Insp	101-0384-15	3	Construction	\$ 2.460000	6%	\$ 2.607600	Construction inspection of the Leonard WTP	Reference WTP Prelim Design Technical Memorandums	
01/2019	67	70 MGD Leonard WTP Site Phase I - Materials Testing - Construction	11-Cnstr	101-0384-15	3	Construction	\$ 1.060000	6%	\$ 1.123600	Construction material testing of the Leonard WTP	Reference WTP Prelim Design Technical Memorandums	
08/2019	70	84" PL from Leonard WTP to Hwy 5 Pump Station (McKinney No. 4) - Construction	11-Cnstr	101-0425-16	5	Construction	\$ 112.000000	6%	\$ 118.720000	Construction of the 84-inch treated water pipeline	Reference prelim mapping (TWPL Align Alternates.PDF)	
09/2019	71	84" PL from Leonard WTP to Hwy 5 Pump Station (McKinney No. 4) - Inspection	10-Insp	101-0425-16	5	Construction	\$ 0.569000	6%	\$ 0.603140	Construction inspection of the 84-inch treated water pipeline	Reference prelim mapping (TWPL Align Alternates.PDF)	
09/2019	72	84" PL from Leonard WTP to Hwy 5 Pump Station (McKinney No. 4) - Materials Testing - Construction	11-Cnstr	101-0425-16	5	Construction	\$ 1.060000	6%	\$ 1.123600	Construction material testing of the 84-inch treated water pipeline	Reference prelim mapping (TWPL Align Alternates.PDF)	
TOTAL TREATMENT & TREATED WATER DISTRIBUTION							\$ 383.654000		\$ 404.331800			
TOTAL SWIFT							\$ 1,070.203000		\$ 1,117.404310			

PART
#54



Lower Bois d'Arc Creek Reservoir Transportation Plan

Prepared for:

North Texas Municipal Water District

May 2011

Prepared by:

FREESE AND NICHOLS, INC.
4055 International Plaza, Suite 200
Fort Worth, Texas 76109
817-735-7300

NTD06128

North Texas Municipal Water District



Kevin R. Johnson 5/3/11
FREESE AND NICHOLS, INC.
TEXAS REGISTERED
ENGINEERING FIRM
F-2144



Vuibin Kau 05.03.2011
FREESE AND NICHOLS, INC.
TEXAS REGISTERED
ENGINEERING FIRM
F-2144

Prepared by:
FREESE AND NICHOLS, INC.
4055 International Plaza, Suite 200
Fort Worth, Texas 76109
817-735-7300

NTD06128

Table of Contents

EXECUTIVE SUMMARY	ES-1
1.0 INTRODUCTION	2
2.0 FM 1396 Relocation	3
2.1 Options	3
2.2 Design Considerations.....	5
2.3 Estimated Costs	5
2.4 Coordination with State and Local Agencies.....	6
2.5 Geotechnical Data	6
2.6 Preferred Alignment for FM 1396	7
3.0 County Roads.....	8
3.1 Process – Objectives.....	8
3.2 Costs.....	8
3.3 Recommendations	8
4.0 Summary.....	11

List of Tables

Table 2.1	Analysis of Different Alignment Options for FM 1396.....	3
Table 2.2	Total Costs for FM 1396 Options Based on Different Bridge Heights.....	5
Table 3.1	County Road Plan Cost Estimate.....	10

List of Figures

Figure 1	FM 1396 Alignment Options.....	4
Figure 2	Overall County Road Recommendations	9
Figure 3	Final Transportation Plan (USGS Map).....	12
Figure 4	Final Transportation Plan (Aerial).....	13

Appendices

Appendix A FM 1396 Bridge Cost Estimate

Appendix B Meeting Minutes

Appendix C Draft Design Summary Report (DSR)

Appendix D Geotechnical Data for FM 1396 Bridge

EXECUTIVE SUMMARY

NTMWD is planning to develop a water supply reservoir on Bois d'Arc Creek. The proposed reservoir, Lower Bois d'Arc Creek Reservoir, would be created by an earthen dam located in Fannin County about 15 miles northeast of Bonham, Texas. The proposed reservoir would have a surface area of about 16,500 acres and a storage capacity of about 367,600 acre-feet with a normal pool elevation of 534 feet msl.

This Lower Bois d'Arc Creek Reservoir Transportation Plan report summarizes the discussions, agreements and results of an effort by North Texas Municipal Water District (NTMWD), Texas Department of Transportation (TxDOT) and Fannin County to address the future transportation needs in the area of the proposed Lower Bois d'Arc Creek Reservoir.

The details of this report contain:

- (1) Coordination details with state and local agencies
- (2) Alternatives considered and the preferred alignment of FM 1396
- (3) Alternatives considered for addressing County Roads affected by the proposed reservoir

Information in this report includes geographic, geological and cost data prepared during the transportation planning process with respect to modifying the transportation network located in the proposed Lower Bois d'Arc Creek Reservoir limits. A detailed topographic survey, property survey, geotechnical investigation and design will be required to further define the impacts and better define the costs of the proposed improvements.

The primary TxDOT road that could be impacted by the proposed reservoir is FM 1396. The current alignment of FM 1396 spans one of the widest portions of the proposed reservoir and would impact recreational uses if relocated in the same location. Several different options were studied and are included in this report. The recommendation is Option 4, construct a new bridge over the reservoir by extending FM 897 North of Lannius. It is recommended to construct this bridge with a low chord elevation of 551 (approximately 17' clearance above normal pool). The estimated cost is \$32.14M not including engineering, surveying, permitting, etc.

In addition to FM 1396, there are 27 county roads that could be impacted by the proposed reservoir. A majority of the county roads located within the footprint of the proposed reservoir are shorter in length and therefore make up a smaller portion of the proposed transportation plan for this project. It is recommended to reconstruct nine crossings at a higher elevation, leave 13 crossings in place and close five crossings, all at an estimated cost of \$5.1M, not including engineering, surveying, permitting, etc.

1.0 INTRODUCTION

The North Texas Municipal Water District submitted an application for a State of Texas water rights permit for the proposed Lower Bois d'Arc Creek Reservoir project in December 2006. An application for a Section 404 permit was submitted to the Tulsa District of the U.S. Army Corps of Engineers (USACE) in June 2008. In support of the permitting activities associated with this project, a transportation planning study was completed to evaluate alternative routes and costs associated with abandonment, relocation or reconstruction of the existing roadway infrastructure.

Various Fannin County and TxDOT roadways are located within the area proposed to be inundated by constructing the proposed Lower Bois d'Arc Creek Reservoir. TxDOT's major road in the area is FM 1396, a two-lane asphalt roadway. The existing roadway would be inundated by the proposed reservoir following construction and therefore alternatives were developed to provide transportation access across the lake. These alternatives were developed to obtain consensus from the parties involved of the preferred alignment of the roadway. With these alternatives, the impact to the landowners, recreational opportunities of the proposed reservoir, costs and impact to the transportation network were analyzed. Fannin County has 27 other roadways that could be affected by the proposed reservoir, most of which are unimproved surfaces.

The purpose of this report is to identify the roadways that could be impacted by the proposed reservoir project and propose solutions for maintaining the transportation connectivity throughout the county. Conceptual level cost estimates for the proposed solutions have been prepared for budgeting purposes.

2.0 FM 1396 RELOCATION

2.1 Options

FM 1396 is an existing two-lane TxDOT asphalt road located within the proposed reservoir limits. The affected portion of roadway is located northwest of the community of Honey Grove. The existing roadway and bridge lie within the proposed reservoir boundary and therefore would need to be raised or relocated as part of the proposed reservoir construction. Various options were investigated with respect to landowner impacts, cost, schedule and travel time for the relocation of FM 1396. These are summarized below and shown in Figure 1.

1. Reroute FM 1396 around the proposed dam
2. Reconstruct FM 1396 along the existing alignment (raise road and new bridge)
3. Relocate FM 1396 approximately 10,000 feet to southwest with a new alignment and bridge
4. Replace FM 1396 by extending FM 897 North out of Lannius with a new bridge over the proposed reservoir
5. Terminate FM 1396 at the shoreline and provide no new route over or around the proposed reservoir

Table 2.1 summarizes some of the advantages and disadvantages for each proposed option.

Table 2.1 Analysis of Different Alignment Options for FM 1396

Option	Advantages	Disadvantages
1	<ul style="list-style-type: none"> • No bridge would be needed over the proposed reservoir 	<ul style="list-style-type: none"> • May impact the Caddo National Grasslands • Additional travel time vs. the existing route
2	<ul style="list-style-type: none"> • Existing FM 1396 roadway outside of proposed reservoir boundary could be utilized • No additional travel time 	<ul style="list-style-type: none"> • Restricts water surface area for recreational purposes • Longest length of bridge required
3	<ul style="list-style-type: none"> • Similar travel time to existing alignment 	<ul style="list-style-type: none"> • Restricts water surface area for recreational purposes • Longer length of bridge required than Option 4 • Requires a new roadway to be constructed on the northern and southern sides of the reservoir (existing County Road ROW may be utilized)
4	<ul style="list-style-type: none"> • Preferred alignment of County, TxDOT, and NTMWD • Maximizes water surface area for recreational purposes • Similar travel time to existing alignment • Shortest bridge length required 	<ul style="list-style-type: none"> • Requires a new roadway to be constructed on the northern and southern sides of the reservoir (existing County Road ROW may be utilized)
5	<ul style="list-style-type: none"> • Least expensive alternative 	<ul style="list-style-type: none"> • Dramatically increases travel time in area

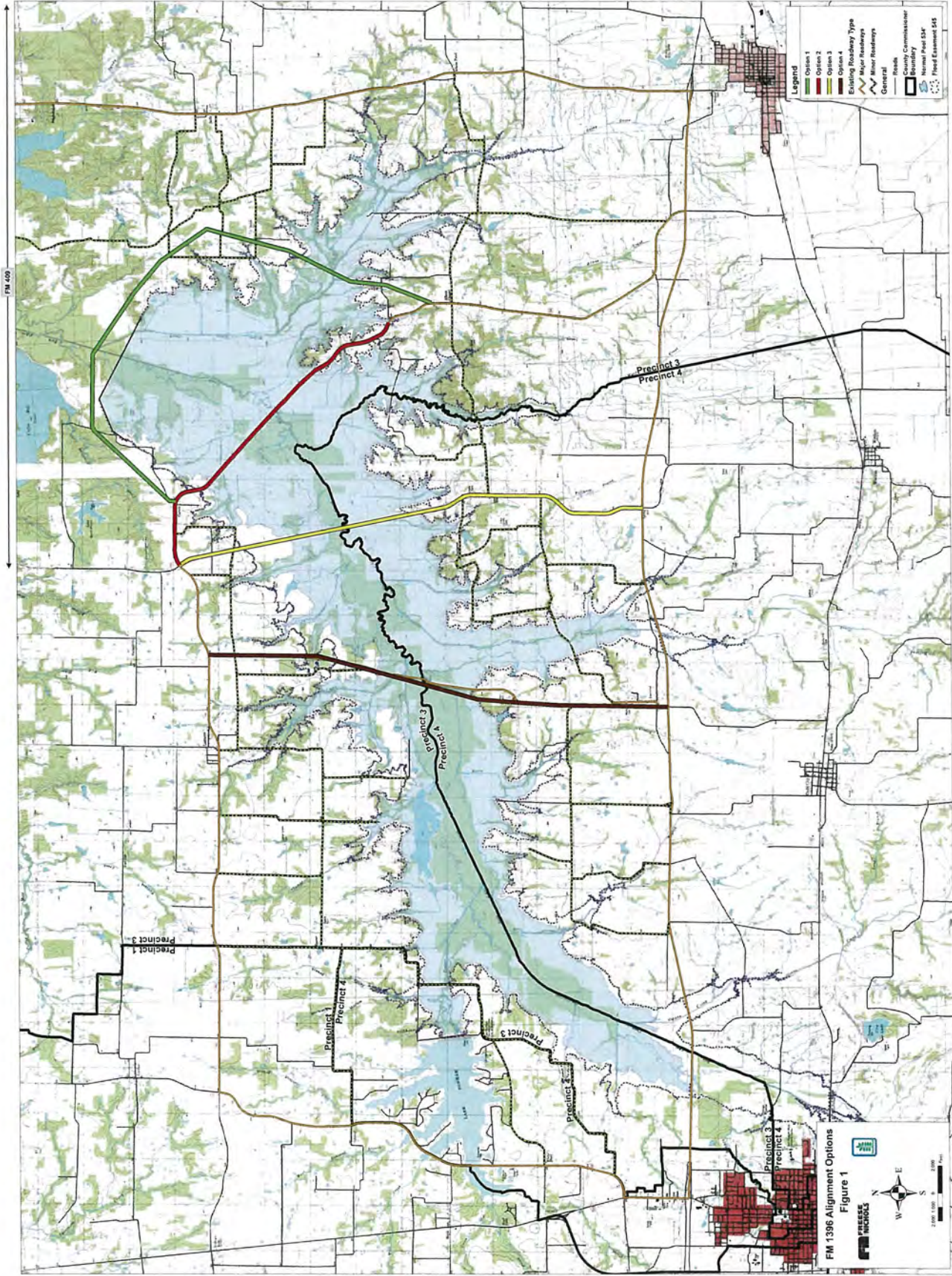

2.2 Design Considerations

Various standards and guidelines were considered for the design assumptions made in this plan. TxDOT design guidelines were utilized for the roadway standards. TxDOT and regional requirements for proposed drainage improvements were considered for the county road improvements. The bridge height recommendation was developed based on maximizing the recreation potential and from discussions with City of Dallas staff regarding Lake Ray Hubbard. Dallas recently utilized a minimum 15' clearance above normal pool for a new bridge across the Lake and feels that it provides an adequate clearance for recreational purposes and for maintenance and operational activities.

2.3 Estimated Costs

Conceptual level construction costs were developed for the various options. These costs include Rights-of-Way (ROW), bridge and roadway costs for each alternative. Cost estimates for Option 1 and 5 were not developed due to these being considered impractical alternatives. Cost estimates for Options 2-4 were developed and are shown below in Table 2.2. These estimates are conceptual in nature due to the limited investigation, research and data available.

Table 2.2 Estimated Costs for FM 1396 Options Based on Different Bridge Heights¹

Option	Bottom of Bridge = 546 (12' clearance) ²	Bottom of Bridge = 551 (17' clearance) ²	Bottom of Bridge = 556 (22' clearance) ²	Bottom of Bridge = 561 (27' clearance) ²
1	Not developed			
2	\$33.65 M	\$36.72 M	\$39.89 M	\$45.53 M
3	\$35.31 M	\$37.17 M	\$39.97 M	\$45.27 M
4	\$29.86 M	\$32.14 M	\$34.62 M	\$38.64 M
5	Not developed			

¹ Engineering, surveying, materials testing and construction management costs are not included.

² Clearances are referenced from the normal pool elevation of 534'.

- Detailed cost estimating data is included in Appendix A.
- Soil for embankment is from on-site source.
- Drilled shafts for bridge piers are approximately 50' deep.
- ROW costs are assumed at \$0.50 per sq. ft.
- The road costs are approximately \$500/LF.

Bridge heights referenced in Table 2.2 are based on clearance intervals above normal pool elevation of 534'. The normal pool elevation of 534' is approximately 7' below the emergency spillway elevation of 541'.

2.4 Coordination with State and Local Agencies

Extensive coordination occurred between North Texas Municipal Water District (NTMWD), Fannin County and Texas Department of Transportation (TxDOT) with regards to the transportation opportunities around the proposed Lower Bois d'Arc Creek Reservoir. These entities have been coordinating the proposed roadway improvements associated with proposed reservoir construction for several years.

Detailed discussions have taken place on the transportation plan regarding the County and TxDOT improvements within the proposed reservoir area. These meetings are summarized below:

- 5/18/07 - Meeting at TxDOT in Sherman – Discussed TxDOT & County Roads (TxDOT, NTMWD, FNI)
- 3/12/09 – Meeting at Fannin County Courthouse in Bonham – Discussed TxDOT & County Roads (Fannin County, TxDOT, NTMWD, FNI)
- 12/2/09 – Meeting at Fannin County Precinct 4 Office – Discussed County Roads (Fannin County, NTMWD, FNI)
- 12/29/09 – Meeting at Fannin County Office in Bonham - Discussed County Roads (Fannin County, TxDOT, NTMWD, FNI)
- 2/5/10 – Meeting at TxDOT Bonham Office – Discussed TxDOT & County Roads (Fannin County, TxDOT, NTMWD, FNI)
- 3/26/10 – Meeting at TxDOT Paris District Office to begin Design Summary Report (DSR) (Fannin County, TxDOT, NTMWD, FNI)

Meeting minutes were prepared for the meetings on 12/29/09 and 3/26/10 and are included in Appendix B. The draft DSR prepared on 2/5/10 is included in Appendix C.

2.5 Geotechnical Data

Freese and Nichols performed a geotechnical investigation in the approximate location of Option 4. The purpose of this investigation was to provide additional information for cost estimating. A summary of the findings in the geotechnical study, as well as the boring logs can be found in Appendix D.

The assumptions made with regards to soil types and depths of rock were confirmed with the investigation. The four borings performed showed a variety of clay material in the area of Option 4. The on-site material will be suitable for embankment of the roadway, although some soil reinforcement may be required.

An analysis was done to determine at what height it became more cost effective to utilize a bridge in lieu of embankment. Based on the soil condition and cost estimates developed, it was determined that the bridge cost equaled embankment cost when the fill height is 45'. Based on

this analysis the cost estimates assume embankment will be used along the roadway when the height of the road is less than 45'. When the height of the road exceeds 45' from the natural ground, a bridge will be utilized.

2.6 Preferred Alignment for FM 1396

Based on the alternatives analysis performed, multiple discussions with TxDOT and Fannin County, all entities have agreed the preferred alignment is Option 4. This option will replace FM 1396 by extending FM 897 North out of Lannius with a new bridge over the proposed reservoir. It is also our recommendation to construct the proposed FM 1396 Bridge at a proposed height of approximately 15' to 17' above the normal pool elevation. This elevation will allow adequate height for recreational purposes and any maintenance and operational activities that may need to occur on the reservoir and the bridge. The final elevations and clearances will be determined during design.

This option would provide similar travel times to the existing alignment and would likely maximize the recreational opportunity of the proposed reservoir. Some additional details and requests by the parties involved are outlined below:

- TxDOT has requested the new FM 897 be designed to TxDOT Farm to Market Road Standards with 120' ROW and a 70 mph design speed.
- TxDOT would assume maintenance of the new FM 897 extension and associated bridge after construction is complete.
- TxDOT would end maintenance on existing FM 1396 at the intersection with FM 2029 on the North side of the proposed reservoir. Fannin County would maintain from this point to the shoreline.
- TxDOT would end maintenance on existing FM 1396 at crossing #12 on the South side of the proposed reservoir. Fannin County would maintain from this point to the shoreline.
- TxDOT requested the pavement be reconstructed and widened (28') along the existing FM 897 through Lannius.
- TxDOT requested the pavement be reconstructed along FM 1396 from Allen's Chapel to crossing #12.
- NTMWD may consider rerouting the existing portion of FM 897 around Lannius (not included in cost estimates).
- Final bridge elevations or lengths have not been decided. Safety, recreational purposes, conveyance of water and many other items should be considered in the final design of the bridge.

3.0 COUNTY ROADS

3.1 Process – Objectives

County roads make up a major component of the transportation network in the proposed Lower Bois d'Arc Creek Reservoir area. A summary of all county road conflicts is shown in Figure 2. An analysis was performed to minimize the impacts of the proposed reservoir to local residents and landowners. In this analysis various items were taken into account to finalize the recommended solutions. These items included:

1. Is the roadway needed?
2. Is there a significant increase in travel distance if a road does not exist?
3. Are there alternative means of ingress/egress?
4. Would the road crossing be inundated by the proposed reservoir?
5. If inundated, at what frequency?

Based on the above criteria the roadways were placed into three categories:

- Reconstruct - Road is needed to maintain access, therefore, it needs to be reconstructed. The road would be reconstructed with a culvert or bridge to maintain access up to the 100-yr storm event.
- Leave in place – The road is desirable to maintain access, but not critical. These roadways would not be inundated by the proposed reservoir's normal pool, and potentially may be inundated at a given storm event. With the proposed reservoir construction, gates would be installed on each side of the potential affected road section, for the county to maintain and close if the roadway is inundated.
- Close Road – The roadway is not required and would be inundated by the proposed reservoir. For these roadways, barricades would be constructed near the shoreline and appropriate "road closed" signage would be placed along the roadway with construction.

3.2 Costs

Conceptual cost estimates were developed for the proposed improvements to the County Roads. These costs are shown in Table 3.1. Depending on the crossing, the cost estimates may include culvert replacements, bridge construction, demolition costs, signage, and/or roadway reconstruction. A hydrologic & hydraulic analysis will need to be performed at each crossing location during final design to determine the proposed improvements.

3.3 Recommendations

Twenty seven county road crossings were identified within the limits of the proposed Lower Bois d'Arc Creek Reservoir. Based on the criteria described above and the agreements with the County Commissioners in those precincts where the crossings are located, five county road crossings would be closed, thirteen county road crossings would be left in place and nine county road crossings would be reconstructed. A map showing these crossings is shown in Figure 2. A table showing the proposed improvements and associated costs of these improvements is shown in Table 3.1

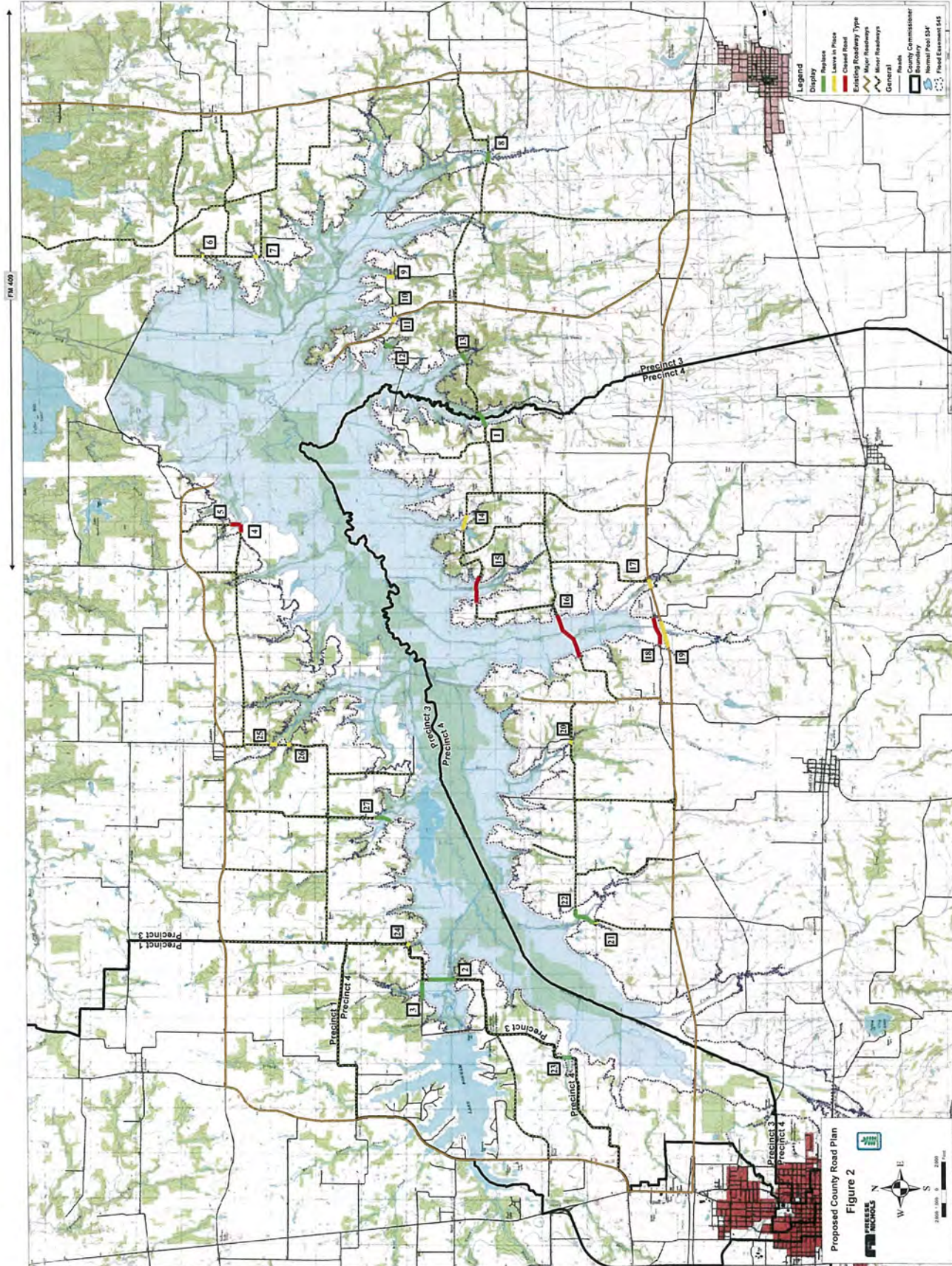

TABLE 3-1: COUNTY ROAD PLAN COST ESTIMATE

LEGEND	
Green	Replace/Reconstruct
Yellow	Leave in place
Red	Close Road

Project #	Road Name	Crossing Name	Needed?	Crossing Type	Project Length (ft)	Add'l Detour Distance (ft)	Road/Bridge Elevation (ft)	Event WSE (ft msl)	Storm event of possible inundation	Recommendation Comment	Bridge Length (ft)	Culvert Cost	Drainage Cost	Existing Road Type	Demo Cost	Signage	Avg. Fill	Roadway Cont/LF	Total Cost
1	CO RD 2610	Ward Creek	Y	Bridge	1,375	N/A	526.50	534.00	Below Normal Pool	TUDOT Reconstruction	100	\$188,000	\$188,000	1L Dirt	\$25,000	\$5,000	9"	5443	\$792,825
2	CO RD 2610	Timber Creek	Y	Bridge	1,971	1,056.00	529.50	534.00	Below Normal Pool	Reconstruct because needed for access and below normal pool	300	\$50,000	\$50,000	1L Dirt	\$25,000	\$5,000	9"	5443	\$792,825
3	CO RD 2610	Sandy Branch	Y	Bridge	1,400	N/A	532.67	534.00	Below Normal Pool	Reconstruct because needed for access and below normal WSE				1L Gravel	\$25,000	\$5,000	8.5"	5329	\$460,600
4	CO RD 2655	No Creek Crossing - Edge of Water	N	N/A	852	60	532.00	534.00	Below Normal Pool	Demo because not needed for access and below normal WSE				1L Gravel	\$25,000	\$5,000			\$30,000
5	CO RD 2670	Unnamed	N	small CMP	1,049	0	532.00	534.00	Above Flood Easement	Not needed for access and above Flood Easement				1L Gravel	\$25,000	\$5,000			\$0
6	CO RD 2725	Unnamed	N	bridge	95	3701	546.50	545	Over 100 Years	Not needed for access and above Flood Easement				1L Dirt	\$5,000	\$5,000			\$5,000
7	CO RD 2730	Honey Grove Creek Tributary	N	small crossing	517	926	545.50	539.7	Over 100 Years	TUDOT Reconstruction	100	\$188,000	\$188,000	1L Gravel	\$25,000	\$5,000	3.5'	5227	\$119,402
8	CO RD 2770	Honey Grove Creek Tributary	N	Bridge is out	616	N/A	539.00	539.7	50 years	Not needed for access and above Flood Easement				1L Gravel	\$5,000	\$5,000			\$5,000
9	CO RD 2745	Honey Grove Creek Tributary	N	Large CMP	540	1130	540.50	545	Above Flood Easement	Needed for access and above Flood Easement				1L Gravel	\$5,000	\$5,000			\$5,000
10	CO RD 2745	Box of Arc Creek Tributary	Y	small crossing	101	N/A	546.38	545	Above Flood Easement	Needed for access and above Flood Easement				1L Gravel	\$5,000	\$5,000			\$5,000
11	FM 1396	Box of Arc Creek Tributary	Y	small ICB	411	N/A	545.62	539.7	Above 100 Year	Reconstruct because needed for access and below normal WSE	100	\$50,000	\$50,000	1L Asphalt	\$25,000	\$5,000	8"	5384	\$182,460
12	CO RD 2985	Unknown	Y	Large CMP	890	N/A	527.25	538.00	Below Normal Pool	Reconstruct because needed for access and below normal WSE				1L Gravel	\$25,000	\$5,000	2.5'	5102	\$187,638
13	CO RD 2985	Youtlum Creek	Y	Unknown	928	N/A	538.50	538.1	50 years	Longer detour length, leave in place, possible inundation about 10 year event				1L Dirt	\$5,000	\$5,000			\$5,000
14	CO RD 2955	Unknown	N	Large CMP	1,211	2400	537.75	531.6	Over 20 Years	Demo because not needed for access and below normal WSE				1L Gravel	\$25,000	\$5,000			\$30,000
15	CO RD 2955	Petignew Branch	N	Large CMP	1,847	1533	532.75	534.00	Below Normal Pool	Demo because not needed for access and below normal WSE				1L Gravel	\$25,000	\$5,000			\$30,000
16	CO RD 2950	Bullard Creek	N	Bridge and Culvert	638	192	548.20	545	Below Flood Easement	Not needed for access and above Flood Easement				1L Asphalt	\$25,000	\$5,000			\$30,000
17	US 82	Cottonwood Creek	N	5 multiple ICB	2,657	N/A	548.20	545	Over 100 Years	Not needed for access and above Flood Easement				1L Asphalt	\$25,000	\$5,000			\$30,000
18	CO RD 2917	Bullard Creek	N	Bridge	1,901	N/A	545.00	545	Above Flood Easement	Not needed for access and above Flood Easement				1L Asphalt	\$25,000	\$5,000			\$30,000
19	US 82	Bullard Creek	N	Bridge	1,401	N/A	545.00	545	Above Flood Easement	Not needed for access and above Flood Easement				1L Gravel	\$5,000	\$5,000			\$5,000
20	CO RD 2900	Orange Branch	N	Bridge	146	882	546.50	545	Above Flood Easement	Not needed for access and above Flood Easement				1L Dirt	\$5,000	\$5,000			\$5,000
21	CO RD 2900	Orange Branch	Y	Large RCP	77	N/A	546.94	545	Above Flood Easement	Not needed for access and above Flood Easement				1L Dirt	\$5,000	\$5,000			\$5,000
22	CO RD 2900	Orange Creek	Y	Bridge	1,831	N/A	539.00	539.1	Almost 50 Years	TUDOT Reconstruction	100	\$50,000	\$50,000	1L Gravel	\$25,000	\$5,000	3.5'	5227	\$392,937
23	CO RD 2610	Box of Arc Creek Tributary	Y	Bridge	485	N/A	539.08	539.1	50 Years	Reconstruct because needed for access				1L Gravel	\$25,000	\$5,000			\$30,000
24	CO RD 2610	Timber Creek	Y	RCP or CMP	230	N/A	543.50	545	Above Flood Easement	Not needed for access and above Flood Easement				1L Gravel	\$25,000	\$5,000	3'	5214	\$105,930
25	CO RD 2610	Box of Arc Creek Tributary	N	Large CMP	376	7826	546.00	545	Above Flood Easement	Not needed for access and above Flood Easement				1L Gravel	\$25,000	\$5,000			\$30,000
26	CO RD 2615	Box of Arc Creek Tributary	N	Large CMP	297	7826	543.25	539.7	Over 100 Years	Not needed for access and above Flood Easement				1L Gravel	\$25,000	\$5,000			\$30,000
27	CO RD 2625	Box of Arc Creek Tributary	Y	2- Large CMP	1,384	N/A	526.50	534.00	Below Normal Pool	Reconstruct because needed for access and below normal pool	100	\$188,000	\$188,000	1L Dirt	\$25,000	\$5,000	8.5"	5417	\$793,428
Total=																			\$5,038,493

LEGEND	
Needed?:	Is the roadway needed to provide access to homes or businesses?
Crossing Type=	Description of the type of creek crossing
Project Length=	Length of road lower than elevation 542 and between flood easements
Add'l Detour Distance	Additional distance driven to avoid the closed creek crossing (if crossing was removed)
Road/Bridge Elevation=	Highest existing elevation along the road or bridge
Event WSE=	Water Surface Elevation associated with the storm event identified in the storm event possible inundation column

4.0 SUMMARY

Fannin County, TxDOT and NTMWD have developed this Proposed Transportation Plan to provide adequate access to and across the proposed reservoir and surrounding properties. This plan would minimize impacts to the residents while maximizing the transportation and recreational opportunities of the proposed reservoir. Figure 3 shows the proposed improvements on a 7.5-minute USGS topographic map and Figure 4 shows the proposed improvements on an aerial photo.

The total cost of improvements needed would be approximately \$32.14M for the FM 1396 bridge and \$5.1M for the improvements needed on the county roads. These costs are for construction only and do not include engineering, surveying, permitting, etc. These findings are a result of extensive coordination with local governing bodies to provide limited impact to users of the existing Fannin County roadways within and adjacent to the proposed reservoir site.

The associated cost estimates are conceptual in nature and should be refined by completing a preliminary design. This preliminary design should include detailed surveys to better understand the impacts to associated properties and the geometric challenges associated with the roadway realignment. This preliminary design effort would allow a more accurate construction cost to be developed.

FM 400

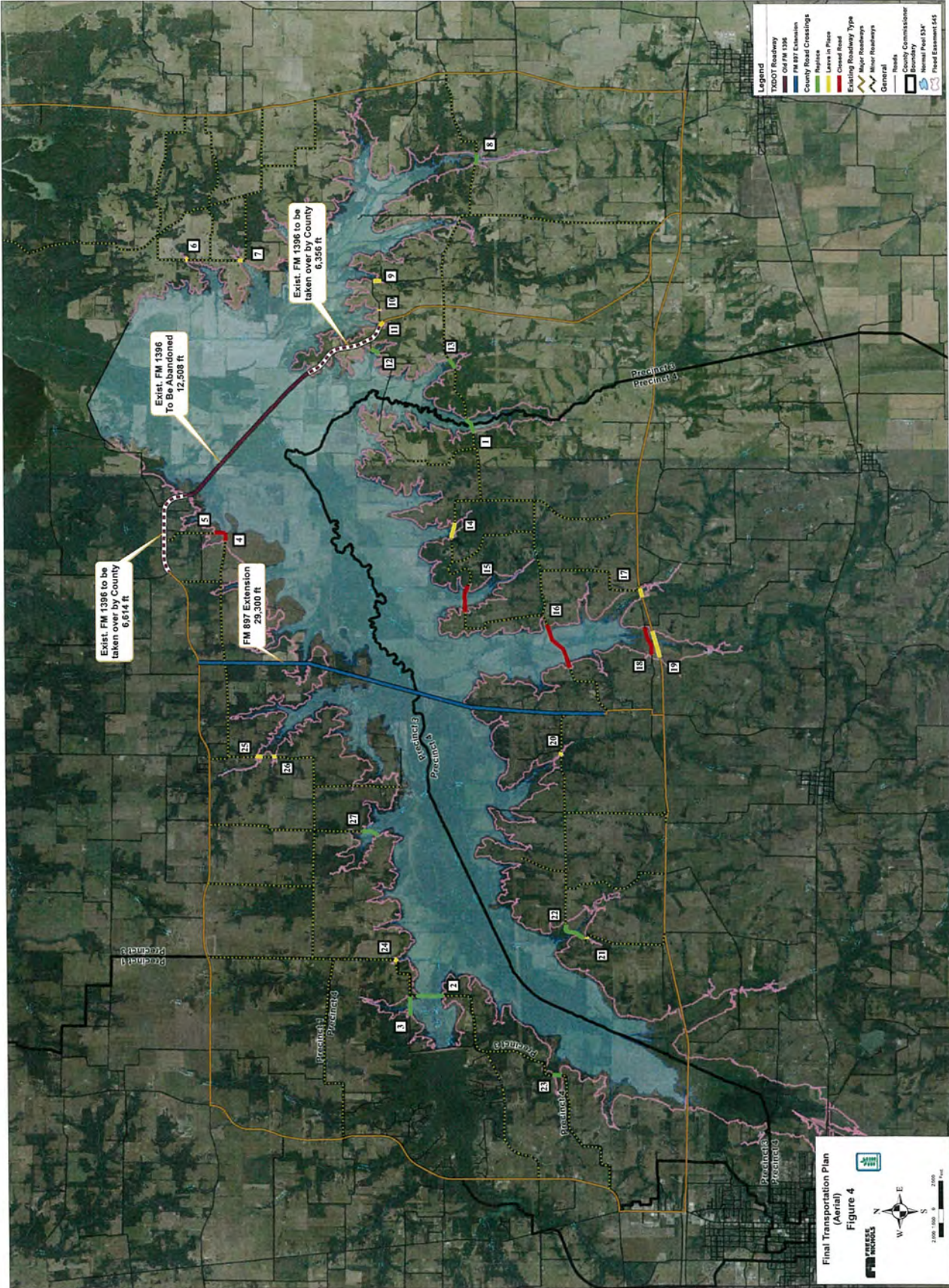

Final Transportation Plan
(Aerial)
Figure 4

Scale: 0 1000 2000 Feet

APPENDIX A

FM 1396 Bridge Cost Estimate

Option #3 - Project Costs Summary

Segment	Segment length	ROW width	ROW cost	ROW total	Pavement width	Road Cost	Road + ROW Cost
North of Reservoir	4759	120	\$ 0.50	\$ 285,540.00	44	\$ 2,379,500.00	\$ 2,665,040.00
South of Reservoir	17156	120	\$ 0.50	\$1,029,360.00	44	\$ 8,578,000.00	\$ 9,607,360.00
TOTAL	21915	Bridge (Approximately 6500')					\$ 12,272,400.00

Bridge height	Cost	Total Project Ccost (bridge + road)
5'	\$ 23,034,081	\$ 35,306,481
10'	\$ 24,894,627	\$ 37,167,027
15'	\$ 27,698,590	\$ 39,970,990
25'	\$ 32,993,417	\$ 45,265,817

Option #4 - Project Costs Summary

Segment	length	ROW width	ROW cost	ROW total	Pavement width	Road Cost	Road and ROW Cost	Pavement Cost
North of Reservoir	8994	120	\$ 0.50	\$539,640.00	44	\$ 4,497,000.00	\$ 5,036,640.00	\$ 500.00
South of Reservoir	13477	120	\$ 0.50	\$808,620.00	44	\$ 6,738,500.00	\$ 7,547,120.00	
TOTAL	22471	Bridge (Approximately 6000')					\$ 12,583,760.00	

Bridge height	Cost	Total Project Cost (bridge + road)
5'	\$ 17,277,441	\$ 29,861,201
10'	\$ 19,559,342	\$ 32,143,102
15'	\$ 22,036,056	\$ 34,619,816
25'	\$ 26,053,587	\$ 38,637,347



LOWER BOIS D'ARC RESERVOIR
NORTH TEXAS MUNICIPAL WATER DISTRICT
PRELIMINARY BRIDGE COST ESTIMATE

OPINION OF PROBABLE CONSTRUCTION COST

OCTOBER 15, 2009

ESTIMATOR	CHECKED BY	ACCOUNT NO
VBK		NTD06128

Fill Height, ft	Fill Volume, CY/LF	Total Fill \$/LF for \$7/CY Fill	Total Fill \$/LF for \$6/CY Fill	Total Fill \$/LF for \$5/CY Fill	Total Fill \$/LF for \$4/CY Fill	Total Fill \$/LF for \$3/CY Fill	Bridge Cost, \$/LF	% increase / LF of height
20	85.9	\$ 1,006	\$ 890	\$ 774	\$ 658	\$ 542	\$ 2,280	
25	125.9	\$ 1,384	\$ 1,214	\$ 1,044	\$ 874	\$ 704	\$ 2,304	0.21%
30	173.3	\$ 1,832	\$ 1,598	\$ 1,364	\$ 1,130	\$ 896	\$ 2,328	0.21%
35	228.1	\$ 2,350	\$ 2,042	\$ 1,734	\$ 1,426	\$ 1,118	\$ 2,352	0.21%
40	290.4	\$ 2,938	\$ 2,546	\$ 2,154	\$ 1,762	\$ 1,370	\$ 2,376	0.20%
45	360.0	\$ 3,596	\$ 3,110	\$ 2,624	\$ 2,138	\$ 1,652	\$ 2,400	0.20%
50	437.0	\$ 4,324	\$ 3,734	\$ 3,144	\$ 2,554	\$ 1,964	\$ 2,931	4.42%
55	521.5	\$ 5,122	\$ 4,418	\$ 3,714	\$ 3,010	\$ 2,306	\$ 2,974	0.29%
60	613.3	\$ 5,990	\$ 5,162	\$ 4,334	\$ 3,506	\$ 2,678	\$ 3,017	0.29%
65	712.6	\$ 6,928	\$ 5,966	\$ 5,004	\$ 4,042	\$ 3,080	\$ 3,059	0.28%
70	819.3	\$ 7,936	\$ 6,830	\$ 5,724	\$ 4,618	\$ 3,512	\$ 3,514	2.97%
75	933.3	\$ 9,014	\$ 7,754	\$ 6,494	\$ 5,234	\$ 3,974	\$ 3,568	0.31%
80	1054.8	\$ 10,162	\$ 8,738	\$ 7,314	\$ 5,890	\$ 4,466	\$ 4,006	2.46%

AVG = 1.26%

Indicates the approximate break even point between fill option and bridge option.

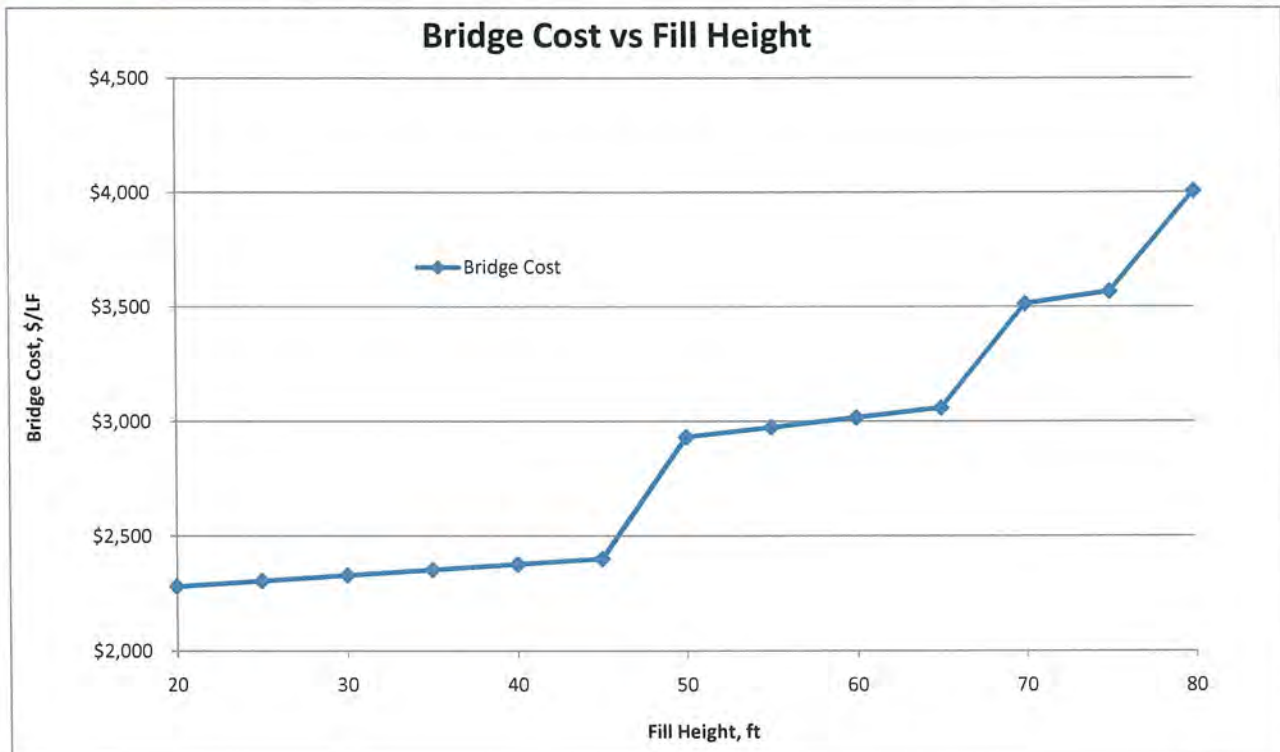

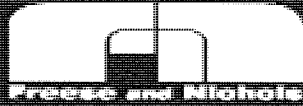

LOWER BOIS D'ARC RESERVOIR
 NORTH TEXAS MUNICIPAL WATER DISTRICT
 PRELIMINARY BRIDGE COST ESTIMATE

OPINION OF PROBABLE CONSTRUCTION COST

SEPTEMBER 28, 2009

ESTIMATOR	CHECKED BY	ACCOUNT NO
VBK		NTD06128

Alignment 2				
Free Board Above EL 541	Bridge Cost	Approaches	Total	% increase / LF of height
5	\$ 31,058,280	\$ 2,586,516	\$ 33,644,796	1.8%
10	\$ 34,244,355	\$ 2,475,311	\$ 36,719,666	1.7%
15	\$ 37,949,310	\$ 1,939,577	\$ 39,888,887	1.4%
25	\$ 43,447,115	\$ 2,078,039	\$ 45,525,154	AVG 1.8%

Alignment 3				
Free Board Above EL 541	Bridge Cost	Approaches	Total	% increase / LF of height
5	\$ 17,898,025	\$ 5,136,056	\$ 23,034,081	1.6%
10	\$ 20,392,720	\$ 4,501,907	\$ 24,894,627	2.3%
15	\$ 23,770,155	\$ 3,928,435	\$ 27,698,590	1.9%
25	\$ 30,423,020	\$ 2,570,397	\$ 32,993,417	AVG 2.2%

Alignment 4				
Free Board Above EL 541	Bridge Cost	Approaches	Total	% increase / LF of height
5	\$ 13,208,325	\$ 4,069,116	\$ 17,277,441	2.6%
10	\$ 17,727,940	\$ 1,831,402	\$ 19,559,342	2.5%
15	\$ 20,640,775	\$ 1,395,282	\$ 22,036,057	1.8%
25	\$ 24,621,385	\$ 1,432,202	\$ 26,053,587	AVG 2.5%

Alignment Option 2 (Reuse FM1396)

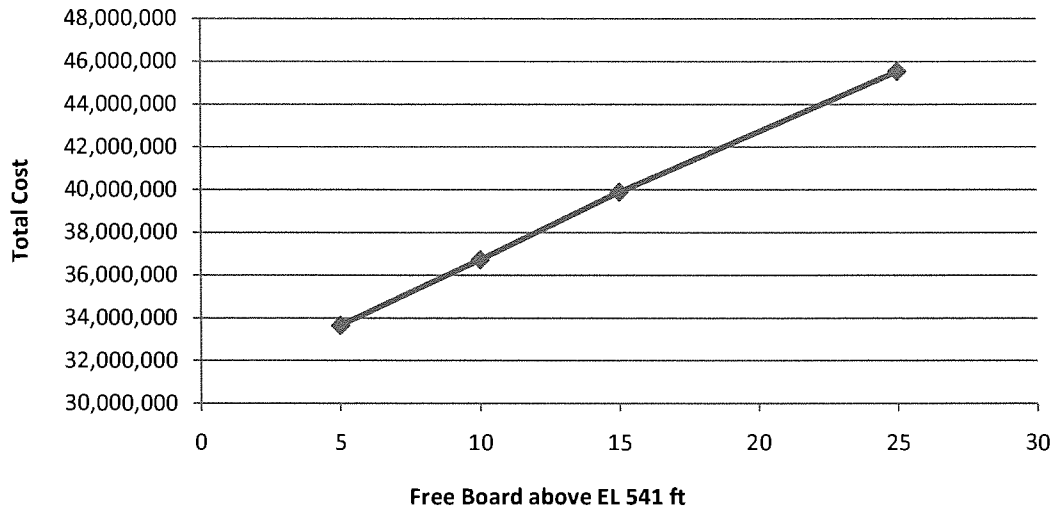

Alignment Option 3

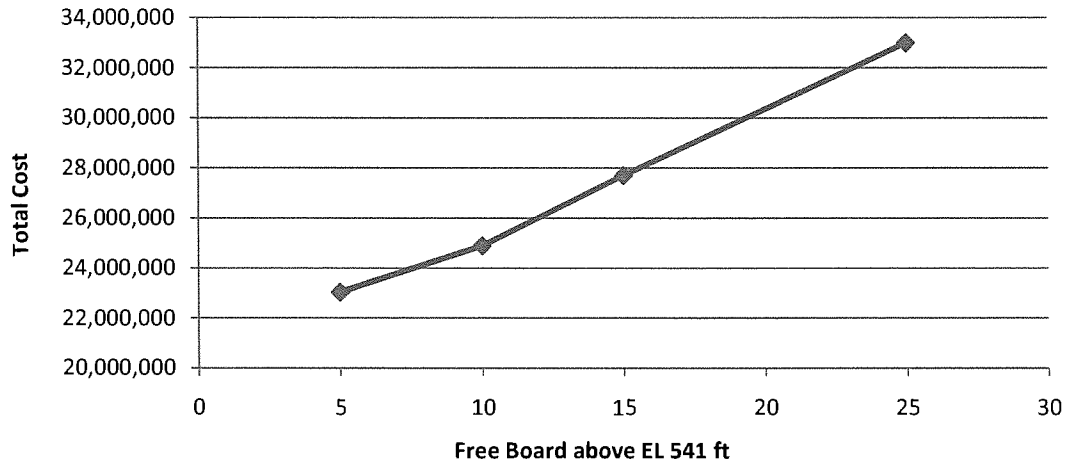

Alignment Option 4 (Preferred)

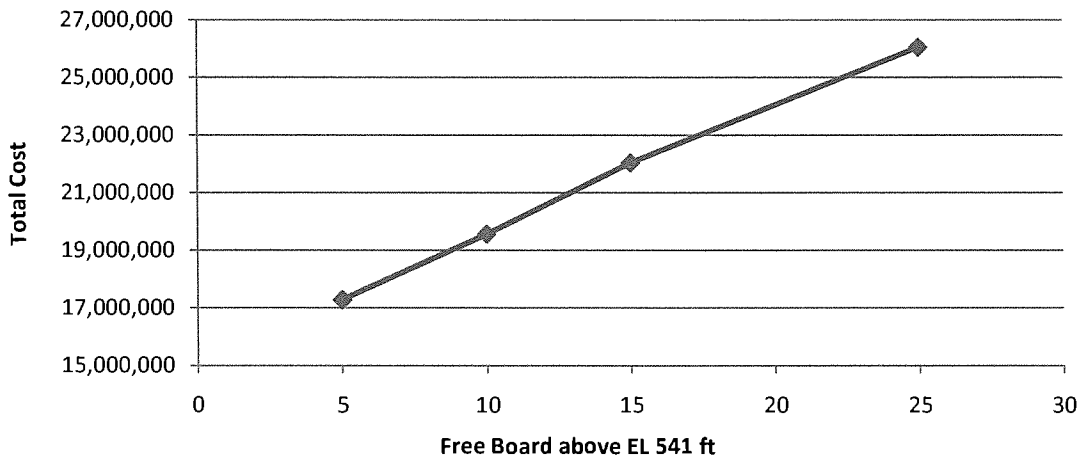



LOWER BOIS DYARC RESERVOIR
NORTH TEXAS MUNICIPAL WATER DISTRICT
PRELIMINARY BRIDGE COST ESTIMATE

OPINION OF PROBABLE CONSTRUCTION COST

SEPTEMBER 28, 2009

ESTIMATOR
VBK

CHECKED BY

ACCOUNT NO
NTD06128

ITEM	DESCRIPTION	QUANTITY	UNIT	UNIT PRICE	TOTAL
ASSUMPTIONS					
2300FT BRIDGE					
36FT BRIDGE DECK WIDTH					
115FT SPANS					
19 INTERMEDIATE BENTS, 2 ABUTMENTS					
BRIDGE					
36' WIDTH BRIDGE DECK		82,800	SF	\$15.00	\$1,242,000
115' TYPE IV BEAMS, 5/SPAN		11,358	LF	\$130.00	\$1,476,583
T501 BRIDGE RAILS		4,680	LF	\$50.00	\$234,000
7.25' x 4' BENT CAPS		734.7	CY	\$750.00	\$551,000
ABUTMENT CAPS		60.2	CY	\$650.00	\$39,130
7' DIA. COLUMNS, 3/BENT, AVG 95' TALL. (ADD 4.28 CY/bent FOR 1FT OF H)		7,714.4	CY	\$700.00	\$5,400,059
7' DIA. DS, 3/BENT, 50' EACH		2,850	LF	\$600.00	\$1,710,000
3' DIA. DS, 4/ABUT, 50' EACH		400	LF	\$150.00	\$60,000
1.5' DIA. DS, 2/ABUT, 40' EACH		160	LF	\$80.00	\$12,800
SEJA (4"), 36 LF EVERY OTHER BENT		360	LF	\$100.00	\$36,000.00
SUBTOTAL:					\$10,761,572
CONTINGENCY 25%					\$2,690,400
SUBTOTAL:					\$13,451,980
MOBILIZATION 10%					\$1,345,200
SUBTOTAL:					\$14,797,180

PROJECT TOTAL

\$14,797,200
\$178.7/SF
\$6434/LF

NOTES:

1. AT EMBANKMENT HEIGHT OF ABOUT 45', BRIDGE COST AND FILL COST IS ABOUT THE SAME, USING \$6/CY AND \$70/SF BRIDGE COST.
2. P/MT COST = \$36/SY, TY C DEN CONT FILL = \$6/CY, AVG EMBANK HT = 25FT 4:1 SLOPE. EMBANK COST = \$900/LF
3. 40FT HT USE 36" DIA, 41-55FT HT USE 48" DIA, 56-65FT HT USE 54" DIA, 66-80FT HT USE 60" DIA, 81-90FT HT USE 72" DIA, 91-100FT USE 84" DIA

EXTENSION COST = \$6385/LF



LOWER BOIS D'ARC RESERVOIR
 NORTH TEXAS MUNICIPAL WATER DISTRICT
 PRELIMINARY BRIDGE COST ESTIMATE

OPINION OF PROBABLE CONSTRUCTION COST

SEPTEMBER 28, 2009

ESTIMATOR VBK	CHECKED BY	ACCOUNT NO NITD06128
------------------	------------	-------------------------

ITEM	DESCRIPTION	QUANTITY	UNIT	UNIT PRICE	TOTAL
ASSUMPTIONS					
	2300FT BRIDGE				
	36FT BRIDGE DECK WIDTH				
	115FT SPANS				
	19 INTERMEDIATE BENTS, 2 ABUTMENTS				
BRIDGE					
	36' WIDTH BRIDGE DECK	82,800	SF	\$15.00	\$8,550,283
	115' TYPE IV BEAMS, 5/SPAN	11,358	LF	\$130.00	\$1,242,000
	T501 BRIDGE RAILS	4,680	LF	\$50.00	\$1,476,583
	6.25' x 4' BENT CAPS	633.3	CY	\$750.00	\$234,000
	ABUTMENT CAPS	60.2	CY	\$650.00	\$475,000
	6' DIA. COLUMNS, 3/BENT, AVG 85' TALL. (ADD 3.14 CY/bent FOR 1FT OF H)	5,071.1	CY	\$700.00	\$39,130
	6' DIA. DS, 3/BENT, 50' EACH	2,850	LF	\$600.00	\$3,549,770
	3' DIA. DS, 4/ABUT, 50' EACH	400	LF	\$150.00	\$1,425,000
	1.5' DIA. DS, 2/ABUT, 40' EACH	160	LF	\$80.00	\$60,000
	SEJA (4"), 36 LF EVERY OTHER BENT	360	LF	\$100.00	\$12,800
					\$36,000.00
SUBTOTAL:					\$8,550,283
CONTINGENCY				25%	\$2,137,580
SUBTOTAL:					\$10,687,870
MOBILIZATION				10%	\$1,068,790
SUBTOTAL:					\$11,756,660

PROJECT TOTAL \$11,756,700

NOTES:
 1. AT EMBANKMENT HEIGHT OF ABOUT 45', BRIDGE COST AND FILL COST IS ABOUT THE SAME, USING \$6/CY AND \$70/SF BRIDGE COST.
 2. PVMT COST = \$36/SY, TY C DEN CONT FILL = \$6/CY, AVG EMBANK HT = 25FT 4:1 SLOPE. EMBANK COST = \$900/LF
 3. 40FT HT USE 36" DIA, 41-55FT HT USE 48" DIA, 56-65FT HT USE 54" DIA, 66-80FT HT USE 60" DIA, 81-90FT HT USE 72" DIA, 91-100FT USE 84" DIA

EXTENSION COST = \$5063/LF
 \$142,0/SF \$5112/LF



LOWER BOIS D'ARC RESERVOIR
 NORTH TEXAS MUNICIPAL WATER DISTRICT
 PRELIMINARY BRIDGE COST ESTIMATE

OPINION OF PROBABLE CONSTRUCTION COST

SEPTEMBER 28, 2009

ESTIMATOR VBK	CHECKED BY	ACCOUNT NO NITD06128
------------------	------------	-------------------------

ITEM	DESCRIPTION	QUANTITY	UNIT	UNIT PRICE	TOTAL
60" DIA COLUMNS (66FT - 80FT TALL)					
ASSUMPTIONS					
	2300FT BRIDGE				
	36FT BRIDGE DECK WIDTH				
	115FT SPANS				
	19 INTERMEDIATE BENTS, 2 ABUTMENTS				
BRIDGE					
	36' WIDTH BRIDGE DECK	82,800	SF	\$15.00	\$6,756,615
	115' TYPE IV BEAMS, 5/SPAN	11,358	LF	\$130.00	\$1,242,000
	T501 BRIDGE RAILS	4,680	LF	\$50.00	\$1,476,583
	5.25' x 4' BENT CAPS	532.0	CY	\$750.00	\$234,000
	ABUTMENT CAPS	60.2	CY	\$650.00	\$39,130
	5' DIA. COLUMNS, 3/BENT, AVG 73' TALL. (ADD 2.18 CY/bent FOR 1FT OF H)	3,024.4	CY	\$700.00	\$2,117,101
	5' DIA. DS. 3/BENT, 50' EACH	2,850	LF	\$400.00	\$1,140,000
	3' DIA. DS. 4/ABUT, 50' EACH	400	LF	\$150.00	\$60,000
	1.5' DIA. DS. 2/ABUT, 40' EACH	160	LF	\$80.00	\$12,800
	SEJ-A (4"), 36 LF EVERY OTHER BENT	360	LF	\$100.00	\$36,000.00
SUBTOTAL:					\$6,756,615
CONTINGENCY				25%	\$1,689,160
SUBTOTAL:					\$8,445,780
MOBILIZATION				10%	\$844,580
SUBTOTAL:					\$9,290,360

PROJECT TOTAL \$9,290,400

EXTENSION COST = \$3991/LF \$4039/LF
 \$112.2/SF \$4039/LF
 NOTES:
 1. AT EMBANKMENT HEIGHT OF ABOUT 45', BRIDGE COST AND FILL COST IS ABOUT THE SAME, USING \$6/CY AND \$70/SF BRIDGE COST.
 2. PVM COST = \$36/SY, TY C DEN CONT FILL = \$6/CY, AVG EMBANK HT = 25FT 4:1 SLOPE. EMBANK COST = \$900/LF
 3. 40FT HT USE 36" DIA, 41-55FT HT USE 48" DIA, 56-65FT HT USE 54" DIA, 66-80FT HT USE 60" DIA, 81-90FT HT USE 72" DIA, 91-100FT USE 84" DI,



LOWER BOIS D'ARC RESERVOIR
 NORTH TEXAS MUNICIPAL WATER DISTRICT
 PRELIMINARY BRIDGE COST ESTIMATE

OPINION OF PROBABLE CONSTRUCTION COST

SEPTEMBER 28, 2009

ESTIMATOR VBK	CHECKED BY	ACCOUNT NO NTD06128
------------------	------------	------------------------

ITEM	DESCRIPTION	QUANTITY	UNIT	UNIT PRICE	TOTAL
ASSUMPTIONS					
	2300FT BRIDGE				
	36FT BRIDGE DECK WIDTH				
	115FT SPANS				
	19 INTERMEDIATE BENTS, 2 ABUTMENTS				
	BRIDGE				\$5,868,481
	36' WIDTH BRIDGE DECK	82,800	SF	\$15.00	\$1,242,000
	115' TYPE IV BEAMS, 5/SPAN	11,358	LF	\$130.00	\$1,476,583
	T501 BRIDGE RAILS	4,680	LF	\$50.00	\$234,000
	4.75' x 4' BENT CAPS	481.3	CY	\$750.00	\$361,000
	ABUTMENT CAPS	60.2	CY	\$650.00	\$39,130
	4.5' DIA. COLUMNS, 3/BENT, AVG 60' TALL. (ADD 1.77 CY/bent FOR 1FT OF H)	2,013.5	CY	\$700.00	\$1,409,468
	4.5' DIA. DS, 3/BENT, 50' EACH	2,850	LF	\$350.00	\$997,500
	3' DIA. DS, 4/ABUT, 50' EACH	400	LF	\$150.00	\$60,000
	1.5' DIA. DS, 2/ABUT, 40' EACH	160	LF	\$80.00	\$12,800
	SEJA (4'), 36 LF EVERY OTHER BENT	360	LF	\$100.00	\$36,000.00
	SUBTOTAL:				\$5,868,481
	CONTINGENCY			25%	\$1,467,130
	SUBTOTAL:				\$7,335,620
	MOBILIZATION			10%	\$733,570
	SUBTOTAL:				\$8,069,190

PROJECT TOTAL \$8,069,200

EXTENSION COST = \$3460/LF
 \$97.5/SF
 \$3508/LF

- NOTES:
1. AT EMBANKMENT HEIGHT OF ABOUT 45', BRIDGE COST AND FILL COST IS ABOUT THE SAME, USING \$6/CY AND \$70/SF BRIDGE COST.
 2. PVMT COST = \$36/SY, TY C DEN CONT FILL = \$6/CY, AVG EMBANK HT = 25FT 4:1 SLOPE. EMBANK COST = \$900/LF
 3. 40FT HT USE 36" DIA, 41-55FT HT USE 48" DIA, 56-65FT HT USE 54" DIA, 66-80FT HT USE 60" DIA, 81-90FT HT USE 72" DIA, 91-100FT USE 84" DIA



LOWER BOIS D'ARC RESERVOIR
NORTH TEXAS MUNICIPAL WATER DISTRICT
PRELIMINARY BRIDGE COST ESTIMATE

OPINION OF PROBABLE CONSTRUCTION COST

SEPTEMBER 28, 2009

ESTIMATOR
VBK

CHECKED BY

ACCOUNT NO
NTID06128

ITEM	DESCRIPTION	QUANTITY	UNIT	UNIT PRICE	TOTAL
ASSUMPTIONS					
	2300FT BRIDGE				
	36FT BRIDGE DECK WIDTH				
	115FT SPANS				
	19 INTERMEDIATE BENTS, 2 ABUTMENTS				
BRIDGE					
	36' WIDTH BRIDGE DECK	82,800	SF	\$15.00	\$5,006,749
	115' TYPE IV BEAMS, 5/SPAN	11,358	LF	\$130.00	\$1,242,000
	T501 BRIDGE RAILS	4,680	LF	\$50.00	\$1,476,583
	4.25' x 3.75' BENT CAPS	403.8	CY	\$750.00	\$234,000
	ABUTMENT CAPS	60.2	CY	\$650.00	\$39,130
	4' DIA. COLUMNS, 3/BENT, AVG 48' TALL. (ADD 1.4 CY/bent FOR 1FT OF H)	1,272.7	CY	\$700.00	\$890,923
	4' DIA. DS, 3/BENT, 50' EACH	2,850	LF	\$250.00	\$712,500
	3' DIA. DS, 4/ABUT, 50' EACH	400	LF	\$150.00	\$60,000
	1.5' DIA. DS, 2/ABUT, 40' EACH	160	LF	\$80.00	\$12,800
	SEJ-A (4"), 36 LF EVERY OTHER BENT	360	LF	\$100.00	\$36,000.00
SUBTOTAL:					\$5,006,749
CONTINGENCY 25%					\$1,251,690
SUBTOTAL:					\$6,258,440
MOBILIZATION 10%					\$625,850
SUBTOTAL:					\$6,884,290

PROJECT TOTAL

\$6,884,300

NOTES:

1. AT EMBANKMENT HEIGHT OF ABOUT 45', BRIDGE COST AND FILL COST IS ABOUT THE SAME, USING \$6/CY AND \$70/SF BRIDGE COST.
2. PVMT COST = \$36/SY, TY C DEN CONT FILL = \$6/CY, AVG EMBANK HT = 25FT 4:1 SLOPE. EMBANK COST = \$900/LF
3. 40FT HT USE 36" DIA, 41-55FT HT USE 48" DIA, 56-65FT HT USE 54" DIA, 66-80FT HT USE 60" DIA, 81-90FT HT USE 72" DIA, 91-100FT USE 84" DIA

EXTENSION COST = \$2945/LF

\$83.1/SF

\$2993/LF



LOWER BOIS D'ARC RESERVOIR
 NORTH TEXAS MUNICIPAL WATER DISTRICT
 PRELIMINARY BRIDGE COST ESTIMATE

OPINION OF PROBABLE CONSTRUCTION COST

SEPTEMBER 28, 2009

ESTIMATOR

VBK

CHECKED BY

ACCOUNT NO

NTID06128

ITEM	DESCRIPTION	QUANTITY	UNIT	UNIT PRICE	TOTAL
36" DIA COLUMNS (UP TO 40FT TALL)					
ASSUMPTIONS					
	2300FT BRIDGE				
	36FT BRIDGE DECK WIDTH				
	115FT SPANS				
	19 INTERMEDIATE BENTS, 2 ABUTMENTS				
BRIDGE					
	36' WIDTH BRIDGE DECK	82,800	SF	\$15.00	\$4,009,063
	115' TYPE IV BEAMS, 5/SPAN	11,358	LF	\$130.00	\$1,476,583
	T501 BRIDGE RAILS	4,600	LF	\$50.00	\$230,000
	3.25' x 3.75' BENT CAPS	308.8	CY	\$750.00	\$231,563
	3' DIA. COLUMNS, 3/BENT, AVG 35' TALL. (ADD 0.79 CY/BENT FOR 1FT OF H)	522.0	CY	\$700.00	\$365,418
	3' DIA. DS, 3/BENT, 4/ABUT, 50' EACH	2,850	LF	\$150.00	\$427,500
	SEJA (4"), 36 LF EVERY OTHER BENT	360	LF	\$100.00	\$36,000.00
	SUBTOTAL:				\$4,009,063
	CONTINGENCY			25%	\$1,002,270
	SUBTOTAL:				\$5,011,340
	MOBILIZATION			10%	\$501,140
	SUBTOTAL:				\$5,512,480

PROJECT TOTAL

\$5,512,500
\$2397/LF
\$66.6/SF

NOTES:

1. AT EMBANKMENT HEIGHT OF ABOUT 45', BRIDGE COST AND FILL COST IS ABOUT THE SAME, USING \$6/CY AND \$70/SF BRIDGE COST.
2. PVMT COST = \$36/SY, TY C DEN CONT FILL = \$6/CY, AVG EMBANK HT = 25FT 4:1 SLOPE. EMBANK COST = \$900/LF
3. 40FT HT USE 36" DIA, 41-55FT HT USE 48" DIA, 56-65FT HT USE 54" DIA, 66-80FT HT USE 60" DIA, 81-90FT HT USE 72" DIA, 91-100FT USE 84" DIA

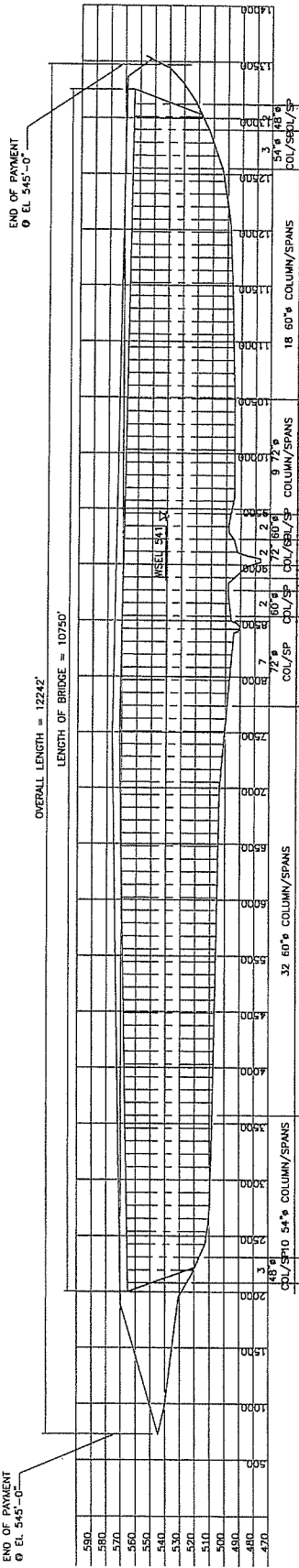

- 36" COLUMN SPANS = \$2597/LF
- 42" COLUMN SPANS = \$2945/LF
- 48" COLUMN SPANS = \$3393/LF
- 54" COLUMN SPANS = \$3841/LF
- 60" COLUMN SPANS = \$4289/LF
- 66" COLUMN SPANS = \$4737/LF
- 72" COLUMN SPANS = \$5185/LF
- 78" COLUMN SPANS = \$5633/LF
- 84" COLUMN SPANS = \$6081/LF

APPROACHES COST = (155586CY + 8515(CY)) * \$61.35 + (14927 * 36FT) * \$41.35 = \$2,078,039

BRIDGE COST = (3+2) * 115 * 2945 + (10+3) * 115 * 3460 + (3+4+2+2+18) * 115 * 3991 + (7+1+2+9) * 115 * 5063 + 4.5 * 54 * 115 * 5460 = \$4,514,172

EXTENSION COST = \$2397 * \$900 = \$1,997,310

TOTAL COST = \$45,525.5A OR \$3719/LF

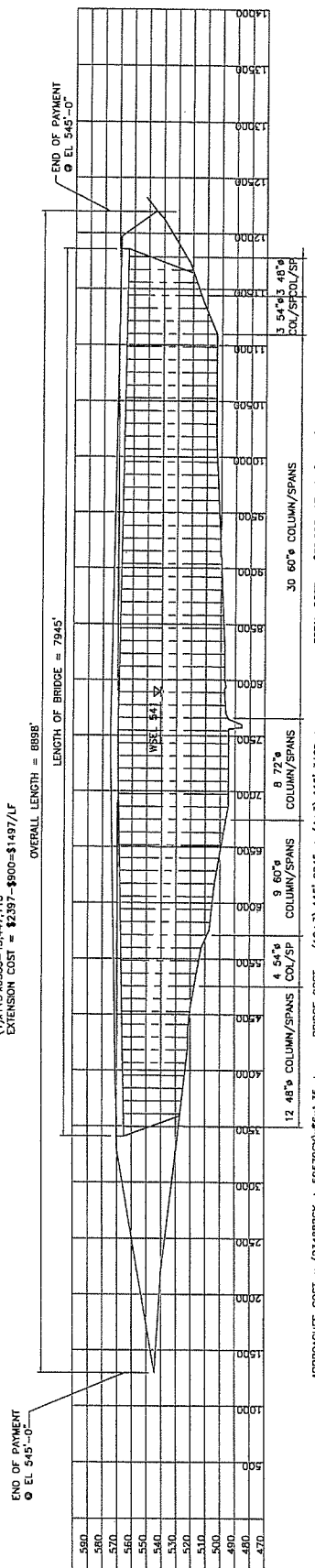

APPROACHES COST = (234882CY + 59578(CY)) * \$61.35 + (9537 * 36FT) * \$41.35 = \$2,570,397

BRIDGE COST = (12+3) * 115 * 2945 + (4+3) * 115 * 3460 + (9+30) * 115 * 3991 + (6) * 115 * 5063 = 30,423,020

EXTENSION COST = \$2397 * \$900 = \$1,997,310

TOTAL COST = \$32,993,417 OR \$3708/LF

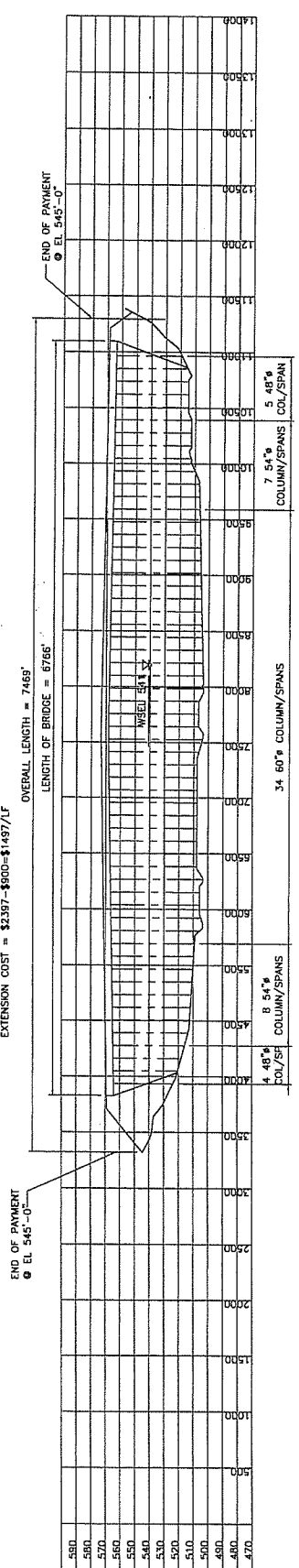

APPROACHES COST = (81575CY + 78358(CY)) * \$61.35 + (7037 * 36FT) * \$41.35 = \$1,432,202

BRIDGE COST = (4+5) * 115 * 2945 + (8+7) * 115 * 3460 + (5A) * 115 * 3991 = 24,621,385

EXTENSION COST = \$2397 * \$900 = \$1,997,310

TOTAL COST = \$26,053,587 OR \$3488/LF

25 FT FREE BOARD FROM WSEL 541

APPENDIX 1725 (REV 7/25) DATE: JAN
 JUN 20 2006 2:06:16 P.M. L15: 1:00 PLS: 1 THST: 0.0 0.0 0.0 0.0 0.0 0.0
 REFERENCE FILES: 90719, 94677, N:\ST\BASK\06-SHM\06-SHM.dwg and N:\STANDARD\348ORDER.dwg

APPENDIX B

Meeting Minutes

PROJECT: Lower Bois d’Arc Creek Reservoir
NAME OF MEETING: FM1396 Discussion
RECORDED BY: Kevin Johnson - FNI
DATE: 12/29/09
LOCATION: Fannin County – South Annex Building
ATTENDEES: **TxDOT** – Bobby Littlefield, David Sellman, Kevin Harris, Noel Paramanatham
Fannin County – Commissioner Hilliard, Commissioner Strickland
NTMWD – Mike Rickman, Robert McCarthy
Freese and Nichols, Inc. – Kevin Johnson

The following reflects our understanding of the items discussed during the subject meeting. If you do not notify us within five working days, we will assume that you are in agreement with our understanding.

DISCUSSION ITEMS

1. Discussed two alternative routes for FM 1396. County and TxDOT discussed the pro’s and con’s to each alternative.
 - a. County & TxDOT agreed to pursue the “Lannius” route. This was the westernmost route shown on the map. This will connect to FM 897 in Lannius and extend North to FM1396
 - b. County & TxDOT agreed to switch maintenance of the existing FM1396 and the proposed route. County will maintain the two remaining segments of existing FM1396:
 - i. From the intersection of FM1396 & FM 2029 to the lake.
 - ii. From the creek crossing on FM1396 (near CR 2745, crossing #12 on map) to the lake.
 - c. TxDOT will maintain the new road
 - d. TxDOT requested the lengths of the existing FM1396 and the proposed route. The old Route was 25,550’ and new route is 29,300’. These are shown on the attached map.
2. We briefly discussed the schedule and plan moving forward. It was decided the next step would be to sit down and put everything on paper with regards to the plan. This would include pavement section, ROW, alignment, design standards, etc. This can be summarized in a Design Summary Report (DSR). A public meeting will also be required for the new route.
3. Discussed the 100 year flood elevation at the US 82 bridge over Bois d’Arc Creek. We received the original as-built plans from TxDOT and will get back with TxDOT on our thoughts on the differences in the floodplain elevations. The TxDOT design utilized a flood elevation of 537 and the recent flood study performed by FNI for the reservoir established an elevation of 541.

ACTION ITEMS

ACTION ITEMS			
WHAT	WHO	WHEN	STATUS
1. Modify maps to show agreed route and lengths	Kevin Johnson	1/6/10	
2. Add Commissioner boundaries to map	Kevin Johnson	1/6/10	
3. Create another map with aerial photo	Kevin Johnson	1/6/10	
4. Coordinate Meeting at TxDOT Paris office for DSR	Kevin Johnson	1/22/10	

PROJECT: Lower Bois d'Arc Creek Reservoir
NAME OF MEETING: FM 1396 & FM 897 Discussion
RECORDED BY: Kevin Johnson - FNI
DATE: 2/5/10
LOCATION: TxDOT – Bonham Office
ATTENDEES: TxDOT – Bobby Littlefield, David Sellman, Kevin Harris, Noel Paramanatham
Fannin County – Commissioner Hilliard, Commissioner Strickland
NTMWD –Robert McCarthy
Freese and Nichols, Inc. – Kevin Johnson

The following reflects our understanding of the items discussed during the subject meeting. If you do not notify us within five working days, we will assume that you are in agreement with our understanding.

DISCUSSION ITEMS

1. Discussed the proposed alternative route for FM 1396, it will be FM 897 from Lannius on the south to FM1396 on the north.
 - a. County will maintain the two remaining segments of existing FM1396:
 - i. From the intersection of FM1396 & FM 2029 to the lake.
 - ii. From the creek crossing on FM1396 (near CR 2745, crossing #12 on map) to the lake.
 - b. TxDOT will maintain FM 897 from Lannius to FM 1396. The amount of roadway removed from the state system will be 25,550' and new route will be 29,300'. These are shown on the attached map.
2. TxDOT requested FM 897 be 44' wide (2-12' lanes & 2-10' shoulders). Designed to Farm to Market road TxDOT standards. 120' – 150' ROW, 70 mph design speed, etc.
3. Discussed the NEPA process and TxDOT's desire to follow. Kevin Johnson asked about building road as County/NTMWD Project to TxDOT standards and conveying to TxDOT after construction is completed. Design & construction would follow all state, federal and local requirements and TxDOT would be involved throughout design. Noel stated TxDOT would discuss and find examples of other projects where this has been done before.
4. TxDOT requested the pavement be replaced on two existing sections of their system:
 - a. Existing FM 1396 from Allens Chapel, north to crossing #12 (where County will take over)
 - b. Existing FM 897 through Lannius. TxDOT would like to have 28' of new pavement vs. the existing 20'
5. Discussed the bridges over Onslott Creek, Ward Creek and Honey Grove Creek. TxDOT has it on the schedule to reconstruct these bridges in the next few years.
 - a. To meet County's desire of maintaining a passable bridge at 100 yr storm event, the pavement will need to be at 541 per 100 yr elevation of lake.

- b. Based on discussion, TxDOT design would likely be low chord of bridge about 536, with bridge section depth, TxDOT's original design may be close to County's preference.
 - c. NTMWD is interested in partnering with TxDOT in design and construction to raise bridge to the desired pavement elevation of 541, based on 100 yr water surface elevation of lake. TxDOT to look at additional cost of this and submit to NTMWD for consideration (contingent upon TCEQ reservoir permit and NTMWD Board Approval). TxDOT requested a letter stating NTMWD's desired elevation of the bridge's.
 - d. This would include the approaches on each side to elevate roadway above 541.
6. Discussed the 100 year flood elevation at the US 82 bridge over Bois d'Arc Creek. The TxDOT design utilized a flood elevation of 537 and the recent flood study performed by FNI for the reservoir established an elevation of 541. No benchmarks could be located on the as-built drawings. FNI to see if we have survey points of top of existing bridge to compare to TxDOT's original design drawings.
 7. Noel stated we need to begin completing the Design Summary Report (DSR) to agree on roadway design geometrics and process. Next meeting would be in TxDOT Paris Office. Meeting date will be mid March, Noel to send some possible meeting dates that works for TxDOT.

ACTION ITEMS

ACTION ITEMS			
WHAT	WHO	WHEN	STATUS
1. TxDOT to discuss if road can follow County process per TxDOT design requirements and be conveyed to TxDOT	Noel Paramanatham	2/19/10	
2. Send Noel the GIS files of the map	Kevin Johnson	2/19/10	
3. NTMWD to send TxDOT letter on bridge elevation	Robert McCarthy	2/26/10	
4. Compare Lake survey shots at bridge to TxDOT drawings	Kevin Johnson	2/19/10	
5. Begin DSR	Kevin Johnson	3/5/10	
6. Next meeting, Noel to determine possible meeting dates and distribute	Noel Paramanatham	Mid March	

APPENDIX C

Draft Design Summary Report (DSR)

Programming Information			
County (s):	Fannin		
Highway (s):	Proposed FM 897		
C-S-J (s):	1175-01-900		
Limits:	From:	US 82	Length:6.31
	To:	FM 1396	
Work Description:	Construct New Location 2 Lane Highway with Shoulders		
Letting Date:	TBD - Projected 2018		
Program Category:	Current:	Local Funds	Expected:
Auth. Funding:	Current:	Local Funds	Required:
Responsible Office Design:	NTMWD	Responsible Office Construction:	NTMWD

Consultants			
Type	Consultant Firm	Oversight	Notes
Land Surveying:			
Aerial Surveying:			
Foundation Exploration:			
Subsurface Utilities:			
Advanced Planning:			
Design:			

Agreements, Permits & Warrants			
Type	With Whom?	Responsible Office	Notes
Advanced Funding			
Right of Way			Coordinate with Tommy Doss (903-510-9140)
Utility Adjustments			TBD
Railroad / Airport			
Illum. Warrants			TBD
Signal Warrants			

Advanced Planning Elements			
Element	Date due to TP&D	Responsible Office	Notes
Schematic		NTMWD	Required
Public Involvement		NTMWD	Required
ROW Map		NTMWD	Required
ROW Plats & Deeds		NTMWD	Required
Utility Adjustments		NTMWD	TBD

Existing Facility			
Element	Number / Slope	Width	Type
Travel Lanes:	2 Lane	12'	Asphalt Surface
Shoulders:	N/A		
Median:			
Front Slopes:	Variable		3:1 Max
Back Slopes:	Variable		3:1 Max
Clear Zone:	16'		
Sidewalks:	N/A		

This proposed project will address the following items of work		
Item		Notes
Travel Lanes	Yes	
Shoulders	Yes	
Median	N/A	
Ditches / Storm Sewers	Yes	
Cross Drainage Culverts	Yes	
Sidewalks	N/A	
ADA Ramps	N/A	
Signals / Illumination	Yes	If meets warrants
Signs / Pvmnt Markings	Yes	
Driveways	Yes	
Driveway Culverts / SETs	Yes	
Mailboxes	Yes	

Proposed Pavement Design Elements			
Element		Element	
Pavement Design Office:	NTMWD	Traffic Data Request Submitted?	No
Current ADT:	460	Functional Classification (#):	Collector
Projected ADT:	500	Urban or Rural?	Rural
% Trucks in ADT:			
Proposed Material Layers:	TBD		
Proposed Riding Surface:	TBD		
Proposed Base:	TBD		
Proposed Base:	TBD		
Proposed Subgrade Treatment:	TBD		
Has existing been cored?	No	Date due to Pavement Engineer:	TBD

Proposed Design Elements		
Element		Notes
Design Standard:	Part IV	
Highway Type:	FM	
Terrain:	Rolling	
Design Speed:	70 mph	
Travel Lanes		
Number:	2	
Width(s):	12'	
Cross Slope:	2.5%	
Shoulders		
Number:	2	
Width(s):	10'	
Cross Slope:	2.5%	
Median		
Type:	N/A	
Width:		
Opening Distance (min):		
Opening Distance (max):		
Slopes		
Front Slope Typical:	6:1	
Front Slope Maximum:	3:1	
Back Slope Typical:	4:1	
Back Slope Maximum:	3:1	
Ditch Bottom Width:	5'	TBD during design phase
Clear Zone Width:	16'	To be verified based on ADT & func. class
Borders		
Border Width:	10'	10' past back slope catch point
Sidewalk Width(s):	N/A	
Geometry		
Horizontal Curve (min):	2050	3405' preferred
Superelevation (max):	6.0%	
k-min (sag):	181	
k-min (crest):	247	
Maximum Grade:	8%	
Minimum Grade:	0.5%	

Structure(s)		
Item		Notes
Cross Culverts		
Design Frequency:	25	
Bridge Structures		
Feature Crossed:	Future Lower Bois d' Arc Reservoir	
Design Frequency:	50	TBD by recreational use
Foundation Type:	TBD	
Sub Structure Type:	TBD	
Super Structure Type:	TBD	
Rail Type:	TBD	
Retaining Walls Type:	TBD	
Prop. Vertical Clearance:	TBD	
Prop. Horizontal Clear:	TBD	
Bridge Approaches		
Approaches exceed 25%?	N/A	
Source of add'l funds	Local	
FEMA		
In FEMA Floodplain?	Yes	
Responsible Office:	NTMWD	

Environmental			
Element	Issue ?	Responsible Office	Notes
Type of Document			
NOI Required?	Yes	NTMWD	To be combined with lake documentation
Permit(s) Required?	YES		
Proposed BMP:	TBD during design phase		
Archeological / Historic?	Yes		
HAZMAT Issues?	Unknown		

This project will require the following		
Item		Reason (s)
Design Exception	TBD	Possible at south end of FM 897
Responsible Office	NTMWD	

Design Waiver	TBD	
Responsible Office		

Additional Notes
1. Schematic layout required
2. Pavement design report required
3. Environmental document as part of overall project or stand alone will be required
4. ROW transfer documentation requirements TBD later
5. This project will include rehab. of existing FM 897 and FM 1396 from Allens Chapel to the point of future county maintenance
6. NTMWD to issue utility permits and driveways on proposed FM 897 according to Txdot guidelines. Use TxDOT forms.

Concurrence			
Duty Position	Name	Signature	Date
Design Engineer	Kevin Johnson		
Designer			
Construct Area Engineer	David Selman		
Director of Construction	Kevin Harris		
Pavement Engineer	Wade Blackmon (interim)		
Director of Operations	Mykol Woodruff		
District Traffic Engineer	Darius Samuels		
Director of TP&D	Ricky Mackey		
Environment Coordinator	Mike Williams		
Right of Way	Keith Hollje		
District Plan Reviewer	Nancy Russell		

Authorization			
District Engineer	Bobby G. Littlefield, Jr., P.E.		

APPENDIX D

Geotechnical Data for Bridge

TO: File NTD06128 - 2.12

FROM: Russell G. Springer, E.I.T.

SUBJECT: Lower Bois D'Arc Reservoir: FM 1396 Relocation Geotechnical Investigation

DATE: July 12, 2010

This memo summarizes the results of the geotechnical investigation for the relocation of FM 1396 as part of the Lower Bois D'Arc Reservoir project. This work was provided as part of FNI project number NTD06128, authorized by the contract with North Texas Municipal Water District (NTMWD), dated February 16, 2006.

PROJECT DESCRIPTION

NTMWD plans to develop a water supply reservoir on Lower Bois D'Arc Creek. The reservoir, Lower Bois D'Arc Reservoir, will be created by an earthen dam located in Fannin County about 14 miles northeast of Bonham, Texas. The reservoir will have a surface area of about 16,500 acres and a storage capacity of about 367,600 acre-feet with a normal pool level at elevation 534 feet msl.

Part of the reservoir development will include the relocation of FM 1396 about 5 miles to the west of the existing road. In addition to the paved roadway, the relocated FM 1396 will include a bridge crossing over the proposed reservoir.

The purpose of this investigation was to provide information for cost estimating purposes and provide soil information for the project.

SUBSURFACE INVESTIGATION

The four borings (B-1 through B-4) were staked in the field and drilled on May 27 through June 1, 2010. The approximate boring locations were determined in the field using aerial photographs and were offset from proposed locations for drill rig accessibility. The actual boring locations were surveyed using a handheld GPS with sub-meter accuracy and are shown on the attached boring location plan.

GM Enterprises drilled the borings using a truck-mounted CME-55 drilling rig. Boring B-1 was drilled using 6-inch solid-stem augers and sampled using 3-inch I.D. thin-walled tubes. Borings B-2 through B-4 were drilled using 6.25-inch hollow stem augers and were sampled using a 3-inch I.D. by 5-foot long



thin-walled continuous sampling barrel. The borings were logged by Mr. Russell G. Springer, E.I.T. and Mrs. Stephanie Coffman of Freese and Nichols, Inc.

The bedrock was evaluated in the borings using the Texas Highway Department cone penetrometer test (TCP) in which a 3-inch diameter cone is driven using a 140-pound automatic hammer falling 30 inches.

The borings were backfilled with cuttings and topped off with a one-foot concrete plug.

Hand-held penetrometer tests were run in the field on cohesive samples, and the results are shown on the boring logs.

The borings were observed for indications of subsurface water entry during drilling and checked for accumulated water after completion of drilling. Groundwater was encountered in all the borings with the exception of Boring B-4.

The borings were logged in the field from inspection of the samples and later edited based on the laboratory test results. The borings logs are attached to this memo.

LABORATORY INVESTIGATION

Laboratory tests were run on selected samples of soil obtained in the field investigation to help classify the materials and evaluate pertinent engineering properties for use in our analyses. Classification and index property tests included water content, dry unit weight, percent passing the No. 200 sieve, and liquid and plastic limits.

All laboratory tests were run by Mas-Tek Engineering and Associates, Inc. in their Dallas, Texas laboratory. The test results are attached this memo. The test results are also shown on the boring logs.

SUBSURFACE CONDITIONS

Geology

The Sherman Sheet of the Geological Atlas of Texas indicates that the borings are underlain by Quaternary alluvial deposits of Recent age, Blossom Sand, and Bonham Marl. The alluvial deposits are described as *"Flood-plain deposits. Along Red River, drainage system includes low terrace deposits; top surface 8±3 feet above the flood-plain surface."*



The alluvial deposits are underlain by the Blossom Sand and Bonham Marl of Upper Cretaceous Age. The Blossom Sand is described as *“quartz sand grading westward into clay. Sand, very fine grained to fine grained, calcareous, glauconitic, ferruginous, calcareous concretions and septaria, thin clay interbeds, brown; weathers brown and red. Clay, silty, calcareous, interbeds of silt, poorly bedded to massive, medium yellowish gray; weathers light yellowish gray; marine megafossils scarce. Thickness 20 feet, feathers out westward in Fannin County.”*

The Bonham Marl is described as *“marl and clay, silty, progressively more calcareous westward, variable amount of glauconite, most abundant near middle, poorly to thinly bedded, medium to light gray; weathers light gray to yellowish gray with poor fissility; marine megafossils; thickness 400± feet.”*

The USDA Soils Survey of Fannin County identifies the soils encountered at Borings B-1 and B-2 as the Tinn clay. The Tinn clay is generally described as very deep, nearly level, moderately well drained, clayey alluvium of Holocene age, located on broad flood plains along streams.

The survey further identifies the soils encountered at borings B-3 and B-4 as the Dela Loam and Derly Silt Loam, respectively. The Dela Loam soils are generally described as very deep, nearly level, moderately well drained, loamy and/or sandy alluvium of Quaternary age, located on flood plains along creeks and drainageways. The Derly Silt Loam soils are generally described as very deep, nearly level, poorly drained, clayey alluvium of Quaternary age, located on the second terrace level of the Red River.

Soils

The borings typically encountered native moderately plastic to highly plastic clay soils at the ground surface or beneath the road base. The clay soils contained varying amounts of sand. The surface soils encountered in Boring B-3 were slightly less plastic with more sand, increasing in plasticity at about 10 feet below the ground surface (bgs). The subsurface soils in Boring B-4 at about 21 feet bgs also indicated a significant decrease in plasticity from the overburden soils. Possible slickensided surfaces with gray staining and ferruginous staining were observed in boring B-2 at depths ranging from about 20 to 26.3 feet bgs.

At depths ranging from about 13 to 30 feet bgs, the borings indicated an increase in sand content with the clay soils transitioning into sandy clay, clayey sand, and silty sand. Boring B-3 terminated in clayey sand at a depth of about 20 feet bgs. The remaining borings encountered weathered and unweathered shale bedrock at depths ranging from about 34 to 39.3 feet bgs.

Moisture contents for the clay soils ranged from 9 to 25 percent with the lower moisture contents obtained in the subsurface clays of lower plasticity and the higher moisture contents obtained in the high plastic clays and soils nearer to the ground surface. Liquid limits for the clayey materials ranged from 30 to 84 and plasticity indices ranged from 16 to 65.



The weathered shale was encountered in Boring B-4 at a depth of about 39.3 feet bgs and was underlain by unweathered shale at a depth of about 41 feet bgs. The weathered shale contained sand and was brown and gray, calcareous, and fossiliferous. Texas Cone Penetrometer testing performed in the weathered shale indicated a penetration of 12 inches for 83 blows.

The unweathered shale encountered in the borings typically contained sand, was brown and gray to dark gray, calcareous, and fossiliferous. Texas Cone Penetrometer testing performed in the unweathered shale indicated penetrations ranging from 2 to 7 inches for 100 blows. Possible slickensides surfaces were observed in the unweathered shale in Boring B-2 at depths ranging from about 36 to 42 feet bgs. Additionally, a thin bentonite seam was observed at about 36.7 feet bgs in boring B-2.

Groundwater was observed in all borings with the exception of Boring B-4. Groundwater observations are summarized in Table 1 below.

Table 1
Groundwater Level Readings

	WLS At Time of Drilling (ATD), feet bgs	WLS After Drilling (AD), feet bgs	WLS After Drilling (AD), feet bgs
B-1	29	6.3 at 0 hrs.	5.0 at 22 hrs.
B-2	28	8.0 at 0 hrs.	--
B-3	14	8.6 at 0 hrs.	--
B-4	Dry	Dry at 0 hrs.	--

WLS = Water Level Surface

bgs = below ground surface

ATD = At Time of Drilling

AD = After Drilling

Please contact me if you have any questions regarding the information in this memo.



FNI Job Number

NTD06128

Date

July 2010

NORTH TEXAS MUNICIPAL WATER DISTRICT
 LOWER BOIS D'ARC RESERVOIR
 BORING LOCATION PLAN

FM 1396 RELOCATION
 BORING LOCATION PLAN



4055 International Plaza
 Suite 200
 Fort Worth, Texas 76109-4895
 Phone - (817) 735-7300
 Fax - (817) 735-7491

FIGURE
 NO.

1

BORING LOG LEGEND AND NOMENCLATURE

Items shown on boring logs refer to the following:

1. Depth - Depth below ground surface in feet
2. Sample - Types designated by letter:
 - S - Split barrel sample, obtained by driving a 2-inch split-barrel sampler unless otherwise noted.
 - U - Undisturbed sample, obtained using a 3-inch-diameter thin-walled tube and open sampling head.
 - NX - Core sample, obtained using an NX-sized core barrel with carbide bit.

Recovery - Sample or Core recovery is the length recovered divided by the total length cored, pushed, or driven, expressed as a percentage.

Resistance - For split-barrel sampling, resistance is designated as follows:
 - 3- Numbers indicate blows per 6 inches of penetration of split spoon sampler driven by a 140-pound hammer falling 30 inches. The Standard Penetration Resistance is the number of blows for the last 12 inches of penetration of the split spoon sampler.
 - 7 50/4" - Number of blows to drive sampler distance shown.

PP- Pocket penetrometer reading in tons per square foot.

RQD- Rock Quality Designation, calculated as the total length of unfractured pieces more than 4 inches long divided by the total length cored, expressed as a percentage.

TCP- Texas Cone Penetration or equivalent variation, resistance blow counts per 6 inches of penetration or penetration distance resulting from 50 blows, whichever occurs first, obtained from driving a 3-inch diameter cone with a 2.5-inch long point using a 170-pound hammer falling 24 inches.
3. Description - Description of material according to the Unified Soil Classification: word description giving soil constituents, consistency or density, and other appropriate classification characteristics. A solid line indicates an approximate location of stratigraphic change. Descriptions may include pertinent observations including type of boring, water seepage, fluid loss, boring termination depth, etc.
4. Legend -

AD - After drilling	ND - Not detectable due to drilling method
ATD - At time of drilling	NR - Not recorded
HSA - Hollow stem auger	RWB - Rotary wash boring
CFA - Continuous Flight Auger	
DWR - Drill water return	
NA - Not Applicable	
5. Remarks - may include the results of field tests or other special observations.
6. Rock hardness and strength - descriptors follow recommendations of the Bureau of Reclamation:

Extremely hard	Cannot be scratched with a knife; can only be chipped with repeated heavy hammer blows.
Very hard	Cannot be scratched with a knife; breaks with repeated heavy hammer blows.
Hard	Can be scratched with a knife with heavy pressure; heavy hammer blows are required to break specimen.

Moderately hard	Can be scratched with a knife with light or moderate pressure; breaks with moderate hammer blow.
Moderately soft	Core can be grooved 1/16 th inch deep with moderate or heavy pressure; breaks with light hammer blow or heavy manual pressure.
Soft	Can be grooved or gouged easily by knife with light pressure; can be scratched with fingernail; breaks with light to moderate manual pressure.
Very soft	Can be readily indented, grooved, or gouged with fingernail, or carved with a knife; breaks with light manual pressure.

Note that descriptors are independent of rock type; a relatively strong shale and a relatively weak limestone might both be called moderately soft.

7. Limitations

The lines between materials shown on the boring logs represent approximate boundaries between material types. The changes may be gradual. Water level readings shown on the logs were made at the time and under the conditions indicated. Fluctuations in the water levels may occur with time. The boring logs in this report are subject to the limitations, explanations and conclusions of this report.



LOG OF BORING NO. B-1

Project Description: Lower Bois D'Arc Reservoir: FM 1396 Relocation
 Project Location: Fannin County, Texas
 Logged By: RGS/SVC
 Drilled By: GM Enterprises

Rig: CME 55

Sheet 1 of 2
 Project No.: NTD06128
 Phase No.: 003A
 Date: 05/27/2010
 Method: 6" CFA

DEPTH, feet	SAMPLE			SYMBOL	Elevation: 506 +/- Northing: 7291389.162 Easting: 2713787.670 Total Depth: 54.1 feet	UNC. COMPRESSIVE STRENGTH (tsf)	WATER CONTENT, %	UNIT DRY WEIGHT, lb/ft ³	% PASSING NO. 200 SIEVE	LIQUID LIMIT	PLASTIC LIMIT	ELEVATION	
	TYPE	RECOVERY (%)	RESISTANCE pp (TSF) RQD										
0	U1	69	1.2 1.0		LEAN TO FAT CLAY (CL-CH), grayish brown and dark brown, stiff, moist, highly calcareous	2.0						505	
	U2	71	0.8 1.5		FAT CLAY (CH), grayish brown and dark brown, medium stiff to stiff, moist, highly calcareous	504.0							
			1.2		- trace medium grained sand at about 4 feet								
5	U3	75	0.7										
	U4	83	1.4 0.9		- more plastic at about 6 feet		25				84	19	500
	U5	21	1.0		- more sand at about 8 feet								
10	U6	85	1.3 2.1		- brown, slightly mottled gray-brown and orange-brown, stiff, trace rootlets, trace small calcareous seams at about 10 feet								495
	U7	63	1.8 1.7		- trace gravel at about 12 feet								
15	U8	63	2.0 1.8										
	U9	52	2.0 1.9		- brown and gray, mottled orange-brown at about 16 feet								490
	U10	79	1.7 1.7		- trace gray fine gravel at about 18 feet		24						
20	U11	67	1.3 1.0		- trace ferruginous staining at about 20 feet								485
	U12	71	1.1 1.6		- trace sand (medium to coarse grained) and gravel (fine, subrounded to well rounded) at about 22 feet								
25	U13	79	1.7 1.9		- siltier, less plastic at about 24 feet								
	U14	75	1.2 2.1			27.0							480
			0.7		LEAN TO FAT CLAY (CL-CH), with fine sand, tan and orange-brown	479.0							
	U15	63	0.6	SANDY LEAN CLAY (CL), silty, tan and orange-brown, medium stiff, moist	28.0		21	65	46	17			
30	U16	67		- soft to medium stiff, wet at about 30 feet	478.0								
					31.0							475	

Water Level Surface 29 feet at ATD
 6.3 feet at 0 hrs. AD
 5.0 feet at 22 hrs. AD

Remarks:



LOG OF BORING NO. B-1

Project Description: Lower Bois D'Arc Reservoir: FM 1396 Relocation
 Project Location: Fannin County, Texas
 Logged By: RGS/SVC
 Drilled By: GM Enterprises

Rig: CME 55

Sheet 2 of 2
 Project No.: NTD06128
 Phase No.: 003A
 Date: 05/27/2010
 Method: 6" CFA

DEPTH, feet	SAMPLE			SYMBOL	Elevation: 506 +/- Northing: 7291389.162 Easting: 2713787.670 Total Depth: 54.1 feet	UNC. COMPRESSIVE STRENGTH (tsf)	WATER CONTENT, %	UNIT DRY WEIGHT, lb/ft ³	% PASSING NO. 200 SIEVE	LIQUID LIMIT	PLASTIC LIMIT	ELEVATION
	TYPE	RECOVERY (%)	RESISTANCE pp (TSF) RQD									
			1.3	[Diagonal Hatching]	CLAYEY SAND (SC), fine grained, gray and brown, moist	475.0			40			
	U17	75			- fine to medium grained at about 32 feet							
	U18	92	4.5+		- with fine gravel seams (subrounded to rounded) at about 33 feet	34.0						
35	TCP		50/2" 50/2.5"	[Horizontal Hatching]	SHALE, brown and gray, soft, fossiliferous, with calcite pockets, calcareous	472.0						470
40	A19 TCP		50/3" 50/1"	[Horizontal Hatching]	- gray, soft to moderately hard at about 39 feet							465
45	TCP		50/2" 50/1.5"	[Horizontal Hatching]								460
50	TCP		50/1.5" 50/1.5"	[Horizontal Hatching]								455
55	TCP		50/1" 50/0.5"	[Horizontal Hatching]	- hard at about 54 feet	54.1						450
					Total boring depth 54.1 ft.	451.9						445



LOG OF BORING NO. B-2

Project Description: Lower Bois D'Arc Reservoir: FM 1396 Relocation
 Project Location: Fannin County, Texas
 Logged By: RGS/SVC
 Drilled By: GM Enterprises

Rig: CME 55

Sheet 1 of 2
 Project No.: NTD06128
 Phase No.: 003A
 Date: 06/01/2010
 Method: 6.25" HSA

DEPTH, feet	SAMPLE			SYMBOL	Elevation: 500 +/- Northing: 7293613.862 Easting: 2714018.123 Total Depth: 50.2 feet	UNC. COMPRESSIVE STRENGTH (tsf)	WATER CONTENT, %	UNIT DRY WEIGHT, lb/ft ³	% PASSING NO. 200 SIEVE	LIQUID LIMIT	PLASTIC LIMIT	ELEVATION
	TYPE	RECOVERY (%)	RESISTANCE pp (TSF) RQD									
0					11.5" Clayey gravel road base	1.0						500
	U1	100	3.0		LEAN CLAY (CL), with silt seams, dark brown and tan, very stiff, slightly moist, stratified, calcareous, trace rootlets	499.0						
			2.6		FAT CLAY (CH), dark brown, slightly moist to moist, non-calcareous, trace ferruginous staining	3.0						
5			2.4									495
	U2	100	2.0		- trace sand, very stiff to hard, slightly calcareous, with calcareous nodules, trace ferruginous staining at about 7 feet	497.0						
			4.5+			10.0						
10	U3	100	4.5+		LEAN CLAY (CL), trace sand, orange-brown and brown, hard, slightly moist, slightly blocky and waxy, more calcareous	490.0	11			40	14	490
			3.5		- very stiff at about 13 feet							
			4.0									
15	U4	100	2.4		- less plastic, moist at about 14.5 feet							485
					- brown and gray at about 16 feet							
20			2.9		- trace gray to gray, less blocky at about 19.7 feet							480
	U5	100	2.8		- possible slickensides with gray staining at about 20.8, 21.4, 22.4, 22.9, and 23.1 feet		9			44	15	
			3.2									
			2.5		- slightly more sand at about 24 feet							
25	U6	98	2.7		- steep angle slickenside with ferruginous staining from about 26.1 to 26.3 feet		13		94			475
			3.0		- tan, with ferruginous staining, less plastic transition from about 27 to 28 feet	28.0						
			1.5		SILTY LEAN CLAY (CL), trace fine sand, tan, stiff, moist, calcareous, with ferruginous staining	472.0						
30					- siltier, more fine sand, medium stiff to stiff, with ferruginous staining at about 29.4 feet	30.5						470
						469.5						

Water Level Surface 28 feet at ATD
 8 feet at 0 hrs. AD
 at

Remarks:



LOG OF BORING NO. B-2

Project Description: Lower Bois D'Arc Reservoir: FM 1396 Relocation
 Project Location: Fannin County, Texas
 Logged By: RGS/SVC
 Drilled By: GM Enterprises

Rig: CME 55

Sheet 2 of 2
 Project No.: NTD06128
 Phase No.: 003A
 Date: 06/01/2010
 Method: 6.25" HSA

DEPTH, feet	SAMPLE			SYMBOL	Elevation: Northing: 7293613.862 Easting: 2714018.123 Total Depth: 50.2 feet	UNC. COMPRESSIVE STRENGTH (tsf)	WATER CONTENT, %	UNIT DRY WEIGHT, lb/ft ³	% PASSING NO. 200 SIEVE	LIQUID LIMIT	PLASTIC LIMIT	ELEVATION
	TYPE	RECOVERY (%)	RESISTANCE pp (TSF) RQD									
	U7	78		[Diagonal Hatching]	SANDY LEAN CLAY (CL), fine to medium grained, trace fine gravel (sub-angular), brown, moist	32.6 467.4			56			
				[Diagonal Hatching]	CLAYEY SAND (SC), medium to coarse grained, gray	34.2 465.8						
35	TCP		50/4" 50/3"	[Horizontal Lines]	SHALE, with sand, dark gray, soft fossiliferous, thinly bedded at top of formation							465
	U8	100		[Horizontal Lines]	- thin bentonite seam at about 36.7 feet - steep slickenside at about 37 feet - steep slickenside at about 37.7 feet							
40	TCP		50/2" 50/1.5"	[Horizontal Lines]	- moderately hard to hard							460
	U9	100		[Horizontal Lines]	- possible slickenside at about 42.2 feet							
45	TCP		50/1.5" 50/0.5"	[Horizontal Lines]	- hard							455
50	TCP		50/1.75" 50/0.75"	[Horizontal Lines]	Total boring depth 50.2 ft.	50.2 449.8						450
55												445
60												440



LOG OF BORING NO. B-3

Project Description: Lower Bois D'Arc Reservoir: FM 1396 Relocation
 Project Location: Fannin County, Texas
 Logged By: RGS/SVC
 Drilled By: GM Enterprises

Sheet 1 of 1
 Project No.: NTD06128
 Phase No.: 003A
 Date: 05/28/2010
 Method: 6.25" HSA

Rig: CME 55

DEPTH, feet	SAMPLE		SYMBOL	Elevation: 504 +/- Northing: 7295181.535 Easting: 2714241.557 Total Depth: 20 feet	UNC. COMPRESSIVE STRENGTH (tsf)	WATER CONTENT, %	UNIT DRY WEIGHT, lb/ft ³	% PASSING NO. 200 SIEVE	LIQUID LIMIT	PLASTIC LIMIT	ELEVATION
	TYPE	RECOVERY (%)									
0											
	U1	100	2.2	CLAYEY SAND (SC), dark brown and brown, very stiff, moist, with rootlets 1.2	502.8						
			1.5	SILTY LEAN CLAY (CL), with fine sand, brown and dark brown, very stiff, moist, with rootlets, non-calcareous - medium stiff from about 2 to 2.7 feet - medium stiff from about 3.1 to 3.5 feet - stiff at about 4 feet		17			35	19	500
5				- medium stiff from about 5.6 feet to 8.5 feet							
	U2	100	0.7	- stiff to very stiff at about 8.5 feet		19					
			1.5		10.0						
10			3.0	LEAN CLAY (CL), brown, stiff, moist 494.0		16			44	17	
	U3	100	2.4	- trace sand, with ferruginous staining at about 12 feet							
			1.8	- with sand, siltier, medium stiff to stiff, with ferruginous staining at about 13 feet	14.5						490
			1.4		489.5						
15			0.5	CLAYEY SAND (SC), gray and light brown, moist							
	U4	58		- coarse sand seam from about 16.6 to 16.9 feet - fine to medium sand seam from about 17.4 to 17.7 feet				45			
					20.0						485
20				Total boring depth 20 ft. 484.0							
											480
											475
30											

Water Level Surface 14 feet at ATD
 8.6 feet at 0 hrs. AD
 at

Remarks:



LOG OF BORING NO. B-4

Project Description: Lower Bois D'Arc Reservoir: FM 1396 Relocation
 Project Location: Fannin County, Texas
 Logged By: RGS/SVC
 Drilled By: GM Enterprises

Sheet 1 of 2
 Project No.: NTD06128
 Phase No.: 003A
 Date: 05/28/2010
 Method: 6.25" HSA

DEPTH, feet	SAMPLE			SYMBOL	Elevation: Northing: Easting: Total Depth: 50.3 feet	UNC. COMPRESSIVE STRENGTH (tsf)	WATER CONTENT, %	UNIT DRY WEIGHT, lb/ft ³	% PASSING NO. 200 SIEVE	LIQUID LIMIT	PLASTIC LIMIT	ELEVATION	
	TYPE	RECOVERY (%)	RESISTANCE pp (TSF) RQD										
0					1" Topsoil/Root zone	0.1							
1.3	U1	92	4.5+	[Diagonal Hatching]	FAT CLAY (CH), trace fine sand, silty, gray, mottled orange-brown, very stiff, sl. moist to dry, with rootlets, non-calcareous - slightly moist to moist at about 0.5 feet - stiff, moist at about 1.3 feet - end of root zone at about 3 feet - very stiff to hard, slightly moist at about 3.6 feet - blocky, with ferruginous staining at about 5 feet - waxy, more plastic at about 6.2 feet	532.9						530	
2.2			4.5+										
4.5+			4.5+										
5	U2	100	4.5+			- silty, trace fine sand, orange-brown and tan, dry, less plastic at about 9 feet - more fine sand at about 10 feet		15			68	19	
10	U3	100	4.5+			- calcareous at about 13 feet - fossiliferous at about 14 feet - trace sand to with sand at about 14.5 feet	15.0						520
15	U4	100	4.5+			LEAN CLAY (CL), with sand, orange-brown and tan, hard, slightly moist, calcareous	518.0	9					515
20			4.5+	[Cross-hatching]	SANDY LEAN CLAY (CL), fine grained to trace medium grained, silty, orange-brown, hard, dry, calcareous - siltier, less clay at about 20 feet	19.0							
			4.5+			SILTY SAND (SM), with occasional very thin silt partings, trace clay, tan and orange-brown, dry to slightly moist	514.0						
	U5	100	4.5+			SILTY LEAN CLAY (CL), trace sand, with occasional thin sand seams, tan, hard, dry, calcareous	512.5 21.0 512.0	10			30	12	510
25	U6	100	4.5+										
30			3.5		- more clay at about 29.8 feet - tan and orange-brown, very stiff, slightly moist at							505	
Water Level Surface Dry at ATD Dry at 0 hrs. AD at					Remarks:								

KEY TO SYMBOLS

Symbol Description

Symbol Description

Strata symbols



Low-high plasticity
clays



High plasticity
clay



Sandy clay



Clayey sand



Shale



Clayey gravel



Low plasticity
clay



Silty Lean Clay



Topsoil



Silty sand



Weathered Shale

Notes:

1. Exploratory borings were drilled on 05/27/2010 through 06/01/2010 using 6-inch diameter continuous flight power augers for Boring B-1 and 6.25-inch hollow stem augers for the rest of the borings.
2. Approximate boring locations can be found on the Boring Location Diagram. Actual boring locations may differ based on existing conditions in the field. Boring coordinates were determined using a handheld GPS with an accuracy of +/-1 meter. Boring elevations were roughly approximated from Google Earth.
3. These logs are subject to the limitations, conclusions, and recommendations in this report.
4. Results of tests conducted on samples recovered are reported on the logs.

MAS-TEK ENGINEERING & ASSOCIATES, INC.
GEOTECHNICAL AND CONSTRUCTION MATERIALS TESTING & ENGINEERING

5132 Sharp Street Dallas, Texas 75247 Phone: 972-709-7384 Fax: 972-709-7385

**REPORT OF ATTERBERG LIMITS, MOISTURE CONTENT AND MATERIAL IN SOILS FINER
 THAN THE NO. 200 SIEVE**

(ASTM D 4318), (ASTM D 2216) and (ASTM D 1140)

PROJECT NAME:	<u>Lab Testing for Lower Bois D'Arc</u>	MTE REPORT No.:	<u>17-064-001</u>
PROJECT NUMBER:	<u>17-064-A</u>	REPORT DATE:	<u>6/29/2010</u>
CLIENT:	<u>Freese and Nichols, Inc.</u>	DATE TESTED:	<u>6/4/2010</u>
CLIENT CONTACT:	<u>Russell G. Springer, P.E.</u>	TECHNICIAN:	<u>D. Randall</u>

Test Results

Bore #	Sample Number	Depth	Moisture Content (%)	-200 Sieve (%)	Liquid Limit (%)	Plastic Limit (%)	Plasticity Index
B1	U15	28 - 30	20.8	65	46	17	29 #
B1	U17	32 - 34		40			
B1	U4	6 - 8	25.2		84	19	65
B1	U10	18 - 20	23.5				
B2	U7A	31.2 - 31.8		55.9			
B2	U6A	25.7 - 26.7	13	94.1			
B2	U3A	10.4 - 11.1	11		40	14	26
B2	U5A	20.8 - 21.4	9.3		44	15	29
B3	U4A	15 - 15.8		45			
B3	U3A	10.6 - 11.3	15.6		44	17	27
B3	U1B	4-4.6	17.4		35	19	16
B3	U2A	6.9 - 7.4	19.1				
B4	U8A	37 - 38		39.5			
B4	U7B	32.9 - 33.4		56.2			
B4	U5B	22.7 - 23.5	10.4		30	12	18
B4	U2B	9 - 9.5	15.3		68	19	49
B4	U4A	16 - 16.6	9.1				

*Test Results Meet Project Specifications Unless Noted With an **

Notes:

<p>Note: This report is for the exclusive use of the Client addressed. This report may not be reproduced except in its entirety, without the written consent of MTE. Results apply only to above tests.</p>

Mas-Tek Engineering & Associates, INC.

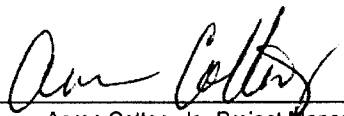

 Aaron Cotton, Jr., Project Manager

PART D
#54



Innovative approaches
Practical results
Outstanding service

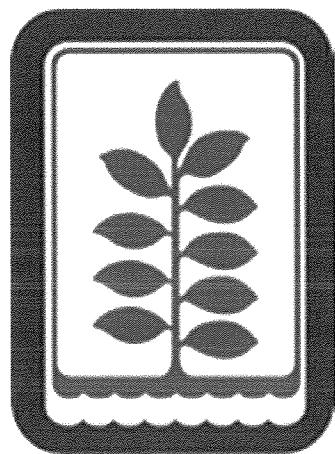

**Design Report for Lower Bois d'Arc Creek
Reservoir Raw Water Pipeline ←
(Project No. 317)**

Prepared for:

North Texas Municipal Water District



Prepared by:

FRESE AND NICHOLS, INC.
2711 North Haskell Avenue, Suite 3300
Dallas, Texas 75204
214-217-2200
NTD13136

Design Report for Lower Bois d'Arc Creek Reservoir Raw Water Pipeline (Project No. 317)

Prepared for: North Texas Municipal Water District

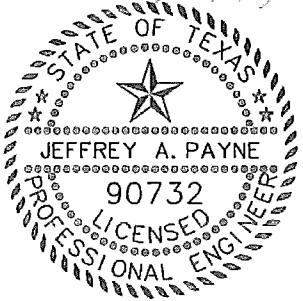
2/13/14



FREESE AND NICHOLS, INC.
TEXAS REGISTERED
ENGINEERING FIRM
F-2144

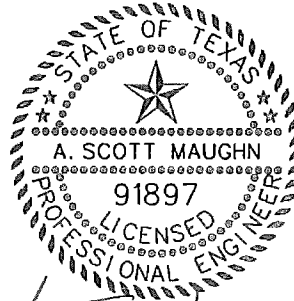

2/13/14



FREESE AND NICHOLS, INC.
TEXAS REGISTERED
ENGINEERING FIRM
F-2144

Prepared by:

FREESE AND NICHOLS, INC.
2711 North Haskell Avenue, Suite 3300
Dallas, Texas 75204
214-217-2200

NTD13136

TABLE OF CONTENTS

Introduction.....1

1.0 Corridor study – section a north of us 823

1.1 Section A – North of us 823

1.1.1 Introduction3

1.1.2 Corridor Alternatives4

1.1.3 Detailed Corridor Analysis5

1.1.4 Environmental Analysis 10

1.1.5 Opinion of Probable Construction Cost 11

1.1.6 Recommendation Summary 11

1.1.7 Corridor Crossings..... 12

1.1.8 Conflict Area Cost Analysis 12

2.0 Pipeline Alignment..... 17

2.1 Section A - north..... 17

2.1.1 Introduction 17

2.1.2 Evaluation of Corridors 18

2.1.3 Route Alternatives 18

2.1.4 Detailed Route Analysis..... 19

2.1.5 Opinion of Probable Construction Cost 27

2.1.6 Recommendation Summary 28

2.1.7 Pipeline Crossings..... 28

2.2 Section A - south..... 37

2.2.1 Introduction 37

2.2.2 Evaluation of Corridors 38

2.2.3 Route Alternatives 38

2.2.4 Detailed Route Analysis..... 41

2.2.5 Opinion of Probable Construction Cost 46

2.2.6 Recommendations Summary 47

2.2.7 Pipeline Crossings..... 48

2.3 Section B 51

2.3.1 Introduction 51

2.3.2 Route Alternatives 51

2.3.3 Detailed Route Analysis..... 52

2.3.4 Opinion of Probable Construction Cost 59

2.3.5 Recommendations Summary 60

2.3.6 Pipeline Crossings..... 61

2.4 Section C 70

2.4.1 Introduction 70

2.4.2 Evaluation of Corridors 70



North Texas Municipal Water District

2.4.3	Route Alternatives.....	73
2.4.4	Detailed Route Analysis.....	73
2.4.5	Opinion of Probable Construction Cost	78
2.4.6	Recommendations Summary	79
2.4.7	Pipeline Crossings.....	80
2.5	LBCR Raw Water Pipeline Final Alignment	86
2.5.1	Alignment Summary	86
2.5.2	Opinion of Probable Construction Cost	88
3.0	Preliminary System Hydraulics and Pipe Diameters.....	89
3.1	Flow Rate Analysis	89
3.1.1	LBCR Permitted Diversions	89
3.1.2	Design Flow Rates.....	89
3.1.3	Life Cycle Analysis Flow Rates.....	89
3.2	Design Assumptions	90
3.3	Pipe Diameter Optimization.....	91

LIST OF TABLES

Table 1	– Analysis for Section A North of US 82 Conflict Areas.....	11
Table 2	– Major Transportation, Utility, and Creek Crossings.....	12
Table 3	– Corridor A1 Cost Analysis	13
Table 4	– Corridor A2 Cost Analysis	14
Table 5	– Corridor A2-Aerial Cost Analysis	14
Table 6	– Corridor A3 Cost Analysis	15
Table 7	– Corridor A1-A3 Cost Analysis.....	15
Table 8	– Corridor A1-A3A Cost Analysis.....	16
Table 9	– Corridor B Cost Analysis.....	16
Table 10	– Analysis for Conflict Area #6.....	21
Table 11	– Analysis for Conflict Area #5.....	22
Table 12	– Analysis for Conflict Area #4.....	24
Table 13	– Analysis for Conflict Area #3.....	25
Table 14	– Analysis for Conflict Area #2.....	26
Table 15	– Opinion of Probable Construction Costs	27
Table 16	– Major Transportation, Utility, and Creek Crossings.....	28
Table 17	- Conflict Area #2 Alt A Cost Analysis	29
Table 18	- Conflict Area #2 Alt B Cost Analysis.....	29
Table 19	- Conflict Area #2 Alt C Cost Analysis.....	30
Table 20	- Conflict Area #3 Alt A Cost Analysis	30
Table 21	- Conflict Area #3 Alt B Cost Analysis.....	31
Table 22	- Conflict Area #4 Alt A Cost Analysis	31

North Texas Municipal Water District

Table 23 - Conflict Area #4 Alt B Cost Analysis.....	32
Table 24 - Conflict Area #4 Alt C Cost Analysis.....	32
Table 25 - Conflict Area #4 Alt D Cost Analysis	33
Table 26 - Conflict Area #5 Alt A Cost Analysis	33
Table 27 - Conflict Area #5 Alt B Cost Analysis.....	34
Table 28 - Conflict Area #5 Alt C Cost Analysis.....	34
Table 29 - Conflict Area #5 Alt D Cost Analysis	35
Table 30 - Conflict Area #6 Alt A Cost Analysis	35
Table 31 - Conflict Area #6 Alt B Cost Analysis.....	36
Table 32 - Conflict Area #6 Alt C Cost Analysis.....	36
Table 33 - Conflict Area #6 Alt D Cost Analysis	37
Table 34 – Analysis for Section A Conflict Areas	44
Table 35 – Weighted Route Scores.....	45
Table 36 – Opinion of Probable Construction Costs	47
Table 37 – Major Transportation, Utility, and Waterbody Crossings	48
Table 38 - Conflict Area #1 Alt A Cost Analysis	49
Table 39 - Conflict Area #1 Alt B Cost Analysis.....	49
Table 40 - Conflict Area #1 Alt C Cost Analysis.....	50
Table 41 - Conflict Area #1 Alt D Cost Analysis	50
Table 42 – Analysis for Conflict Area #1.....	54
Table 43 – Analysis for Conflict Area #2.....	55
Table 44 – Analysis for Conflict Area #3.....	56
Table 45 – Analysis for Conflict Area #4.....	57
Table 46 – Analysis for Conflict Area #5.....	58
Table 47 – Analysis for Conflict Area #6.....	59
Table 48 – Opinion of Probable Construction Costs	60
Table 49– Major Transportation, Utility, and W Crossings.....	61
Table 50 – Conflict Area #1 Alt A Cost Analysis.....	62
Table 51 – Conflict Area #1 Alt B Cost Analysis.....	62
Table 52 – Conflict Area #1 Alt C Cost Analysis	63
Table 53 – Conflict Area #2 Alt A Cost Analysis.....	63
Table 54 – Conflict Area #2 Alt B Cost Analysis.....	64
Table 55 – Conflict Area #3 Alt A Cost Analysis.....	64
Table 56 – Conflict Area #3 Alt B Cost Analysis.....	65
Table 57 – Conflict Area #3 Alt C Cost Analysis	65
Table 58 – Conflict Area #3 Alt D Cost Analysis.....	66
Table 59 – Conflict Area #4 Alt A Cost Analysis.....	66
Table 60 – Conflict Area #4 Alt B Cost Analysis.....	67
Table 61 – Conflict Area #5 Alt A Cost Analysis.....	67



North Texas Municipal Water District

Table 62 – Conflict Area #5 Alt B Cost Analysis.....	68
Table 63 – Conflict Area #5 Alt C Cost Analysis.....	68
Table 64 – Conflict Area #6 Alt A Cost Analysis.....	69
Table 65 – Conflict Area #6 Alt B Cost Analysis.....	69
Table 66 – Weighted High Level Route Scores.....	72
Table 67 – Analysis for Conflict Area #1.....	74
Table 68 – Analysis for Conflict Area #2.....	75
Table 69 – Analysis for Conflict Area #3.....	77
Table 70 – Analysis for Conflict Area #4.....	78
Table 71 – Opinion of Probable Construction Costs	79
Table 72 – Major Transportation, Utility, and Creek Crossings	80
Table 73 – Conflict Area #1 Alt A Cost Analysis.....	81
Table 74 – Conflict Area #1 Alt B Cost Analysis.....	81
Table 75 – Conflict Area #2 Alt A Cost Analysis.....	82
Table 76 – Conflict Area #2 Alt B Cost Analysis.....	82
Table 77 – Conflict Area #3 Alt A Cost Analysis.....	83
Table 78 – Conflict Area #3 Alt B Cost Analysis.....	83
Table 79 – Conflict Area #3 Alt C Cost Analysis.....	84
Table 80 – Conflict Area #3 Alt D Cost Analysis.....	84
Table 81 – Conflict Area #3 Alt E Cost Analysis.....	85
Table 82 – Conflict Area #4 Alt A Cost Analysis.....	85
Table 83 – Conflict Area #4 Alt B Cost Analysis.....	86
Table 84 – Final Alignment Opinion of Probable Costs	88
Table 85 – North Water Treatment Plant Phasing	90
Table 86 – Life Cycle Analysis Variables.....	91
Table 87 – Pipe Diameter Present Worth Comparison.....	92

LIST OF FIGURES

Figure 1 – Overall Segment A Corridor Map.....	4
Figure 2 – Corridor A2 LBCR Crossing Profile.....	7
Figure 3 – Corridor A3A LBCR Crossing Profile.....	8
Figure 4 – Evaluated Corridor	17
Figure 5 – Overall Segment A – North Alignments	18
Figure 6 – Aerial View of Conflict Area #6	20
Figure 7 – Aerial View of Conflict Area #5	21
Figure 8 – Aerial View of Conflict Area #4.....	23
Figure 9 – Aerial View of Conflict Area #3	24
Figure 10 – Aerial View of Conflict Area #2	26
Figure 11 – Evaluated Corridor	38

North Texas Municipal Water District

Figure 12 – Overall Segment A – South Alignments.....	39
Figure 13 – Aerial View of Conflict Area #1	40
Figure 14 – Aerial View of Conflict Area #2	41
Figure 15 – Overall Segment B Alignment	52
Figure 16 – Aerial View of Conflict Area #1	53
Figure 17 – Aerial View of Conflict Area #2	54
Figure 18 – Aerial View of Conflict Area #3	55
Figure 19 – Aerial View of Conflict Area #4	56
Figure 20 – Aerial View of Conflict Area #5	57
Figure 21 – Aerial View of Conflict Area #6	58
Figure 22 – Map of Proposed Routes.....	71
Figure 23 – Aerial View of Conflict Area #1	74
Figure 24 – Aerial View of Conflict Area #2	75
Figure 25 – Aerial View of Conflict Area #3	76
Figure 26 – Aerial View of Conflict Area #4	77
Figure 27 – LBCR Overall Recommended Alignment.....	87
Figure 28 – Pipe Diameter Optimization	92
Figure 29 – 90-inch Pipeline HGL.....	93
Figure 30 – 96-inch Pipeline HGL.....	94

APPENDICES

Appendix A – Design Report Figures

Appendix B – Hydraulics Data

INTRODUCTION

The North Texas Municipal Water District (NTMWD) will be constructing raw water transmission facilities as part of the Lower Bois d’Arc Creek Reservoir (LBCR) Project. These facilities include a raw water intake pump station at the proposed Lower Bois d’Arc Creek Reservoir, a terminal storage reservoir located near Leonard, Texas, and approximately 36 miles of 90-inch raw water pipeline. These raw water transmission projects will be part of an overall system of raw water storage and transmission facilities that will be included in the United States Army Corps of Engineers (USACE) 404 Permit required for the for the construction of LBCR.

By contract dated January 30, 2013, the NTMWD authorized Freese and Nichols, Inc. (FNI) to perform raw water transmission studies and to identify locations for various raw water facilities for Project No. 317 which is the LBCR Final Pipeline Alignment Study and referred to as the “The Project” in this report. Final design and construction will require a separate NTMWD Board Authorization in the future. The purpose of this Preliminary Design Report (PDR) is to summarize the raw water transmission studies, document the technical decisions that were made, and provide FNI’s recommendation for the LBCR Raw Water Pipeline alignment. The LBCR Raw Water Pipeline alignment has been split into three design sections that are labeled as Section A, B and C. Section A begins at the proposed LBCR dam and continues south to State Highway (SH) 56. Section B spans from SH 56 to Farm to Market Road (FM) 68. Section C continues from FM 68 to the proposed North Water Treatment Plant (NWTP) site near Leonard, Texas.

This PDR is organized into three primary sections. These sections and their content are summarized below;

- Section 1.0 – Corridor Study – Section A North of 82: This section summarizes the corridor analysis performed for the portion of Section A affected by the decision to move the pump station to the LBCR Dam. This section directs the reader to the Appendices discussing the details of the corridor selection process.
- Section 2.0 – Pipeline Alignment: This section summarizes the overall alignment of the pipeline and directs the reader to the Appendices and a series of technical alignment selection memorandums discussing the details of the alignment selection process.
- Section 3.0 – Preliminary System Hydraulics and Pipe Diameters: This section discusses the



North Texas Municipal Water District

various hydraulic scenarios that were analyzed to determine pipe diameters, interconnections, and design flow rates. This section also discusses sending water from the North Water Treatment Plant near Leonard to Wylie.

1.0 CORRIDOR STUDY – SECTION A NORTH OF US 82

1.1 SECTION A – NORTH OF US 82

1.1.1 Introduction

The corridor for Section A, north of US Highway 82 (US 82), of the LBCR Raw Water Pipeline is defined as a 1,000 foot wide path following a possible pipeline centerline. Once the corridor is selected, the final alignment of the proposed pipeline will be selected from within the chosen corridor. This memo discusses the overall project constraints used to determine the recommended corridor. Selection of the preferred corridor was based on a “desktop” analysis of economic and non-economic factors for various route options. The recommended corridor, documented herein, is used to identify parcels needed for Right-of-Entry (ROE) and is used as a baseline for the first stages of field work and alignment development. The following general parameters were adopted to generate acceptable corridors:

1. Avoid or minimize environmental permitting potential.
2. Align beginning with the proposed Pump Station Site Options.
3. Align end with beginning of Section B.
4. Minimize pipeline length where it does not impact other parameters
5. Minimize impact to landowners along corridor.

This portion of Section A of the LBCR Pipeline is being rerouted due to a decision by the NTMWD to move the pump station site to a location at or near the proposed dam. The shift in the proposed pump station site is also why this Corridor Study is being included in the PDR. Moving the pump station site caused the original Corridor north of US 82 that had been documented and approved via the Technical Memorandum titled “LBCR Conceptual Raw Water Transmission Facilities Design: 404 Permitting Pipeline Route Study, Recommended Pipeline Routes” dated March 11, 2008 to be shifted. The corridors documented and approved via that same Technical Memorandum for south of US 82 on Section A and all of Sections B and C were not affected. The proposed dam will be located approximately 9 miles north-northwest of Honey Grove, Texas. With Section A now beginning at the dam, there are two feasible approaches for the corridor study. The first approach crosses the Honey

North Texas Municipal Water District

Grove Creek arm of the reservoir and the other would be to travel around that arm of the reservoir. The pipeline will begin by heading southeast around the main body of the reservoir. Generally speaking, the pipeline will then head southwest towards the connection point with Section B just east of the intersection of FM 867 and SH 56.

1.1.2 Corridor Alternatives

Five corridors were developed north of US 82 to access the pump station site. The five corridors selected are shown on **Figure 1**. Corridor A1 is shown in dark green, Corridor A2 is shown in red, Corridor A3A is shown in purple and Corridor A3 is shown in teal. Corridor B is shown in lime green. All five corridors share a similar path heading southeast around the main body of the reservoir until

Corridor A1 begins heading south to join up with Corridor A2. Corridor A2 diverges from Corridor B and then heads southwest to cross the Honey Grove Creek arm of the reservoir. Corridor A2 continues heading southwest for approximately five miles where it converges with Corridor B just south of US 82. Corridor A3A continues heading south where Corridor A1 converges with Corridor A2. Corridor A3A then crosses the reservoir at a narrower point than Corridor A2. After crossing the reservoir Corridor A3A turns and heads southwest and converges with Corridor A3. Corridor A3 separates from Corridor A2 shortly after Corridor A2 crosses the reservoir. Corridor A3 then heads on a more south-southwesterly heading than Corridor A2 in order to by-pass a large swath of densely wooded areas with numerous creek crossings and several



Figure 1 – Overall Segment A Corridor Map

North Texas Municipal Water District

potential environmentally sensitive areas. Corridor A2 then converges with Corridor B just south of the US 82. Corridor B begins by heading southeast around the main body and the Honey Grove Creek arm of the reservoir that the other corridors cut across. Once Corridor B clears the large arm of the reservoir, it heads due south for approximately two miles crossing a smaller finger of the reservoir. Corridor B then turns and begins heading southwest for approximately five miles where it converges with Corridor A2 just south of US 82. The final portion of Section A is approximately five miles long and heads southwest towards the connection point with Section B. The location shown for the pump station represents the approximate pump station site selected by the NTMWD on the service spillway.

1.1.3 Detailed Corridor Analysis

The shared beginning of these corridors has only minor issues and is partially contained in land that will be purchased for the reservoir and spillway. The corridor begins by heading southwest from the pump station site. The corridor travels through mostly open cultivated land before going through a densely wooded area. After coming out of the densely wooded area the terrain opens up to uncultivated land with a few abandoned structures. The corridor then crosses County Road (CR) 2725 and it is at this point where Corridors A1 and B diverge. Overall this portion of the corridor has no apparent environmentally sensitive areas, or major transportation and known utility crossings.

As Corridor A1 heads south it follows along the west side of CR 2725/2730 traveling through sparsely wooded open land. As it follows along CR 2725/2730 the corridor comes upon three houses with cultivated lands. Corridor A1 then crosses CR 2730 before traveling into a densely wooded area where it joins up with Corridor A2. Overall this possible corridor has no apparent environmentally sensitive areas that can be identified at this level of analysis. Corridor A1 cuts off about 2,000 feet of corridor as a shortcut to connect with Corridor A2.

As Corridor A2 heads southwest after separating from Corridor B it comes in close proximity (approximately 500') to a family cemetery. It is near this point where Corridor A2 encounters a densely wooded area. After clearing the wooded area the terrain opens back up to cultivated land. In this area Corridor A2 also crosses CR 2740 just before crossing the Honey Grove Creek arm of the reservoir. Corridor A2 has two possible methods of installation within this corridor to cross the reservoir. One option is to install this section of pipeline by open cut with a casing or tunnel liner plate, and the other option is an aerial crossing, which will be discussed in subsequent sections. This arm of the reservoir is

North Texas Municipal Water District

approximately 4,600 feet wide based on the spillway elevation of the reservoir which is at the 534 foot reservoir contour shown in **Figure 1**.

Both options include additional costs beyond the standard installation price per linear foot. These costs are shown in detail in **Tables 4 & 5**.

After the reservoir crossing, Corridor A2 continues to travel southwest and crosses CR 2745 and FM 1396. Immediately after crossing FM 1396, there are five abandoned structures in a wooded area that shows signs of being a potential forested wetland. The environmental analysis performed for the corridor study will be discussed later in **Section 1.1.4 "Environmental Analysis"** of this report. The corridor continues through this wooded area passing through two small plots of cultivated land with houses on each. After this, the corridor heads into a large densely wooded area which Yoakum Creek is located. This area shows signs of potential environmental issues associated with the creek and wooded area. The terrain then briefly opens up into a small cultivated area. In this clearing the corridor also crosses an electrical transmission corridor before entering a sparsely wooded area around Ward Creek that has been flagged as a possible forested wetland. The corridor then crosses through a clearing of uncultivated land before it encounters another sparsely wooded area. As the corridor continues southwest out of the sparsely wooded area, the terrain once again opens up into a clearing. In this clearing the corridor crosses an Atmos 10" transmission gas line. As the corridor continues it passes in between two houses and a small stock tank. There is approximately 900 feet between the two houses. The corridor then crosses US 82 and converges with Corridor B just after crossing FM 1743.

For the portion of the corridor crossing the reservoir, the buried option has inherent maintenance and design concerns. The maintenance issue associated with a long submerged crossing like this is access to the pipe to perform repairs and maintenance throughout the life of the pipeline. With access being the biggest maintenance concern, FNI has provided a conceptual profile view of the reservoir crossing showing a blow-off valve to drain this section of pipe. Along with a manway for access, this would allow for maintenance and repairs on the pipe to be performed from the inside. Also, the annular space between the liner plate and pipe would be grouted for increased stiffness and protection. The constructability issues with this method are that the blow-off valve would be over 40 feet deep and there would be about 1,200 feet of pipe that would be buried deeper than 20 feet. The profile is shown in **Figure 2**.



Figure 2 – Corridor A2 LBCR Crossing Profile

Another possible design concern with a submerged pipe is floating of the pipe. This would be of concern while the reservoir is being impounded or when the pipe is dewatered for maintenance. This buoyancy issue has been analyzed with the following assumptions being made. The weight of the pipe, liner plate and the grout in the void between the pipe and liner plate were ignored as an additional factor of safety. The buoyancy force used in the calculations is the air volume for the cross section of the liner plate and not the carrier pipe. All of the above assumptions were used to provide a conservative answer for the required depth of cover. The analysis indicated that with the suggested factor of safety of greater than 1.47 the pipe would need to be buried with a minimum of six feet of cover. For reference, the buoyancy calculations have been included in **Appendix A**.

The aerial crossing option would also have inherent maintenance and design concerns. The maintenance issues associated with an aerial crossing are that the exterior of the pipe would be exposed to a wider array of elements than if it was buried, and the pipe is more vulnerable to major weather events. The constant exposure to the elements could cause accelerated deterioration of the exterior pipe coating, resulting in additional work, in the form of recoating to maintain the exterior coating in order to avoid negatively affecting the design life of the pipe. The aerial crossing developed for this corridor option was a 24 foot wide bridge with vehicle access for maintenance and 100 foot spans.

The aerial crossing is significantly more expensive than the buried option, approximately \$15 million. If

North Texas Municipal Water District

the corridor crossing the reservoir is chosen, FNI would recommend the buried option for two reasons. It would be less expensive both in the construction phase and maintenance phase of the pipeline and the previously mentioned design and maintenance concerns that the aerial option presents.

Another option for crossing the proposed reservoir is Corridor A3A which continues south at the convergence of Corridor A1 and A2. Corridor A3A then crosses the reservoir arm south of the Corridor A2 reservoir crossing location. After crossing the reservoir, Corridor A3A travels through open uncultivated land before turning southwest. Shortly after turning southwest, Corridor A3A crosses through a wooded area that does not appear to present any environmental issues. During this wooded area the corridor encounters several small ponds, abandoned structures and one house. After passing through the wooded area, the terrain opens up into uncultivated land and converges with Corridor A3 just west of FM 1396. Overall this alignment avoids environmental concerns, shortens the reservoir crossing by approximately 1,000 feet and shallows out the conceptual pipe profile in comparison to Corridor A2. The profile can be seen below in **Figure 3**.

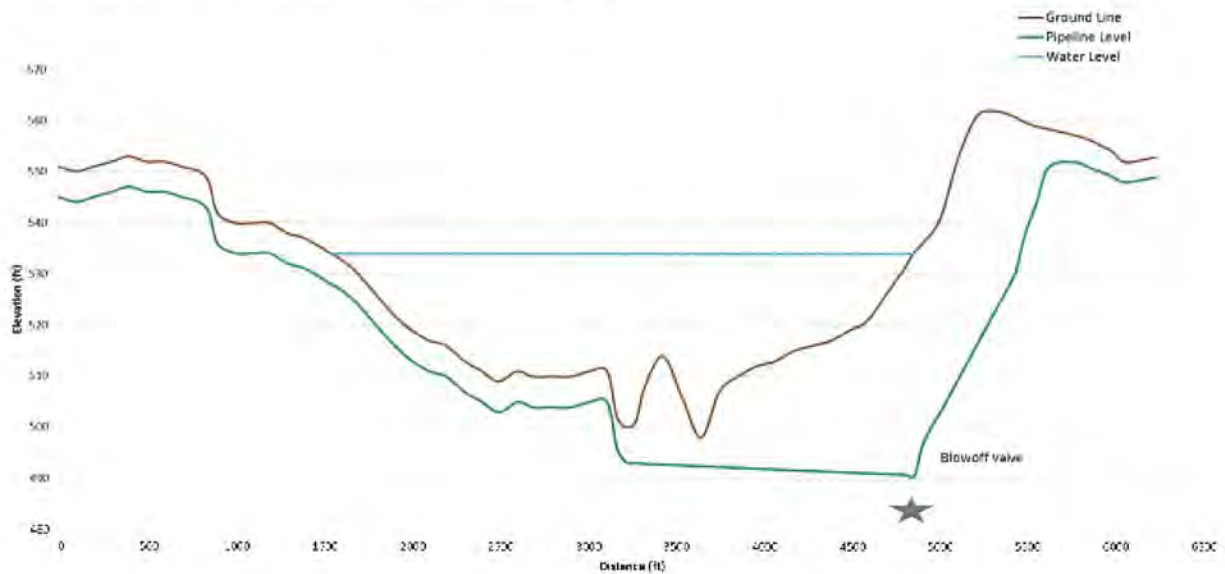

Figure 3 – Corridor A3A LBCR Crossing Profile

Corridor A3 separates from Corridor A2 south of the reservoir crossing and then heads south following through mostly open fields before crossing FM 1396. After crossing FM 1396, the corridor follows just to the west of FM 1396 to avoid the houses near the road. The corridor then travels through sparsely wooded areas before crossing CR 2980. After crossing CR 2980, the terrain changes to a mix of uncultivated and cultivated land and the corridor turns heading southwest. While in this open land the

North Texas Municipal Water District

corridor crosses an Oncor electrical transmission corridor. The A3 corridor continues to head southwest crossing Yoakum Creek and associated riparian zone. This crossing at Yoakum Creek shows signs of potential environmental issues. After crossing the creek the corridor continues southwest across open and cultivated fields. Corridor A3 then crosses Ward Creek near its headwaters, which also shows signs of potential environmental issues. The corridor then continues through open land where it crosses an Atmos 10" transmission gas line. The corridor then crosses CR 2992 shortly before converging with Corridor B. Overall Corridor A3 travels mostly through open and cultivated fields. The locations where it does cross creeks is upstream of Corridor A2 and the riparian zones of the creeks are smaller therefore minimizing the possible environmental impact of the pipeline.

As Corridor B separates from Corridor A1 and continues to head southeast, it travels through a small patch of densely wooded area before crossing through a cultivated field. The corridor then encounters a house and barn located within a densely wooded area just south of the junction of Corridors A2 and B. As the corridor continues heading southeast, it conflicts with a house and several small sheds as well as several ponds before turning to head south. Soon after turning south and going through a clearing, the corridor crosses a small tributary that feeds the reservoir. After clearing the small tributary, the corridor continues through open land and cultivated fields for another mile until crossing a tributary of Honey Grove Creek and turning and to head southwest. Shortly after this change in direction the corridor crosses Honey Grove Creek. These creek crossings may have some environmentally sensitive areas. The corridor then crosses an Oncor electrical transmission corridor as it travels through open land. Shortly after crossing the Oncor electrical transmission corridor, the corridor runs between a house and a large stock tank that has approximately 350 feet of clearance between the two obstacles. The corridor continues heading southwest through mostly open land. Then, just before crossing FM 1396 the corridor crosses three small tributaries and their respective riparian zones. Initial analysis indicates this area may be environmentally sensitive. The corridor then crosses FM 1396 traveling mostly through open and cultivated land before crossing Ward Creek near its headwaters and its corresponding riparian zone. The corridor then travels through open land and cultivated fields. During this portion of the corridor, Corridor B crosses an Atmos 10" transmission gas line before converging with Corridor A3. Soon after converging with Corridor A3, Corridor B encounters two houses and several sheds which shall be avoided. The corridor then crosses US 82 at the CR 2989 intersection. Shortly after this the corridor converges with Corridor A2 just south of FM 1743. Overall Corridor B travels through mostly open lands

North Texas Municipal Water District

or cultivated fields; however, the corridor does include several creek crossings due to Corridor B intersecting the creeks before they converge with one another downstream. This also means that the crossing of the creeks and the respective riparian zones are not as wide as after they converge.

The Shared Southern Corridor has not changed significantly since it was first proposed. At this point the corridors have converged just south of FM 1743. Shortly after they converge, the shared corridor crosses a 3" Atmos distribution line supplying the town of Windom. The corridor then travels through a sparsely wooded area to a more densely wooded area that contains a seasonally flooded creek bed. The shared corridor continues heading southwest through mostly open land with a minor creek crossing. The corridor travels between two adjacent homes with the centerline of the shared corridor approximately 200 feet from either house. Shortly after passing between the houses, there is a creek crossing with associated riparian zones that are not believed to be wetlands. The corridor then travels across open pasture land with a barn and holding pens. Shortly after passing the barn, the shared corridor then crosses Bullard creek just downstream of where Burnett Creek and Bullard Creek converge. The shared corridor then travels through mostly open land and some sporadically wooded areas as the corridor parallels a small creek approximately 400 feet from the centerline of the corridor. The shared corridor then turns and heads due south towards SH 56 to make the connection with Section B. Overall the shared southern corridor travels mostly through open pastures and cultivated land with limited environmental concerns

1.1.4 Environmental Analysis

During the preliminary environmental analysis of the proposed corridors, several areas of concern were identified related to Section 404 permitting. These areas consisted of crossings through potential forested wetland areas as well as areas where the proposed corridor appears to be within, and run parallel to, existing stream beds and crossings at locations where two or more streams converge. The types of data utilized to identify these sites included existing aerial photography, the U.S. Fish and Wildlife Service (USFWS) National Wetlands Inventory (NWI) data, and U.S. Geological Survey (USGS) 7.5-minute topographic maps. It should be noted that these areas were identified at a desktop level with no field work or on-site verification. A more definitive assessment of these sites would require on-site investigations by qualified biologists/environmental scientists to determine if these sites are wetlands (as defined by the USACE) and if the proposed corridor would be within, and parallel to, existing streams, or cross at the confluence of two or more streams.

1.1.5 Opinion of Probable Construction Cost

Below is a summary table of the Opinion of Probable Construction Cost (OPCC). **Table 1** shows length, landowner count, linear feet of pipe in a potential environmentally sensitive area, number of creek crossings, linear feet of pipe crossing under LBCR and the costs associated with the project: construction, land, and total corridor cost. Potential environmentally sensitive areas were defined as any low lying wooded areas and riparian zones in a specific corridor. Corridor A1 is shorter than Corridor A1-A3A by about 2,500 feet but it is only slightly less expensive. Corridor A1's reservoir crossing is 1,000 feet longer than Corridor A1-A3A's crossing and it travels through greater amounts of wooded areas resulting in an increased installation cost. Corridor A2-Aerial is the most expensive due to the cost associated with constructing a 24 foot wide bridge with vehicle access for maintenance and 100 foot spans. While Corridor B is significantly longer (approximately 11,000 feet on average) than the other corridors, it is not proportionally more expensive. Corridor B is roughly 15-20% longer than the other corridors but yields a cost only about 5-6% more than the other corridors (excluding the aerial crossing option). This is due to the substantial length of reservoir that the other corridors must cross.

Table 1 – Analysis for Section A North of US 82 Conflict Areas

Segment	Corridor A1	Corridor A2	Corridor A2 Aerial	Corridor A3	Corridor A1-A3	Corridor A1-A3A	Corridor B
Length	66,220	68,345	68,345	69,885	68,035	68,830	78,849
Landowner Count	47	56	56	54	45	48	62
Pipe in Potential Environmentally Sensitive Areas (ft)	22,273	22,827	22,698	13,434	12,662	13,861	18,022
Creek Crossings	9	8	8	5	6	7	11
Pipe Crossing under LBCR (ft)	4,485	4,485	0	4,485	4,485	3,677	0
Construction Cost	\$68,860,000	\$70,690,000	\$85,860,000	\$71,090,000	\$69,440,000	\$68,810,000	\$72,000,000
Land Cost	\$ 5,000,000	\$ 5,310,000	\$ 5,310,000	\$ 5,350,000	\$ 5,020,000	\$ 5,100,000	\$ 5,790,000
Total Corridor Cost	\$73,830,000	\$76,000,000	\$91,170,000	\$76,440,000	\$74,460,000	\$73,910,000	\$77,790,000

*For further cost analysis data see **Tables 3-9**.

1.1.6 Recommendation Summary

FNI recommends Corridor B, as it avoids several possible forested wetland areas by crossing creeks farther upstream and eliminates crossing any large portion of the reservoir with minimal additional cost. Per our discussion on June 21, 2013 with the NTMWD the additional operations and maintenance concerns associated with crossing under the reservoir outweigh the additional length and cost



North Texas Municipal Water District

associated with this corridor. Corridor A2-Aerial also does not cross underneath the reservoir but the additional cost and recurring maintenance associated with the aerial crossing led to the ultimate selection of Corridor B.

1.1.7 Corridor Crossings

All known utility, transportation and creek crossings for Corridor B are listed below in **Table 2**.

Table 2 – Major Transportation, Utility, and Creek Crossings

Road
Fannin CR 2725
Fannin CR 2720
Fannin CR 2710
Fannin CR 2730
Fannin CR 2770
Fannin CR 2765
Farm to Market 1396
Fannin CR 2992
United States Route 82
Fannin CR 2989
Farm to Market 1743
Utility
Oncor Overhead Electric Transmission Lines
Atmos 10" Gas Distribution Line
Waterbody
Tributary of Honey Grove Creek
LBCR Finger (Fox Creek)
Tributary of Honey Grove Creek (2)
Honey Grove Creek
Tributary of Honey Grove Creek
Allen's Creek
Tributary of Allen's Creek (2)
Tributary of Ward Creek
Ward Creek



North Texas Municipal Water District

1.1.8 Conflict Area Cost Analysis

Tables 3-9 on the following pages show a detailed breakdown of how the costs for each alternate were calculated. Land classification can be either rural or urban but for all of Section A it is rural which is shown as an "R" in the tables. The installation class coincides with the type of land the pipe is traveling through. For instance, Installation Class 1 is "Type 1-Open" which is used when the pipeline is traveling through open land and Installation Class 2 is "Type 2-Wooded" which is used when the pipeline is traveling through wooded land and the same relationship between type and installation class are true for the other installation classes. The line item described as "NTMWD Easement Land Cost Reduction" is meant to show the amount of easement that is to be subtracted from the total land costs because this portion of the line is on property that is already owned by the NTMWD.

Table 3 – Corridor A1 Cost Analysis

ORIGINAL ALIGNMENT Type & Description	SEGMENT PARAMETERS			UNIT COSTS		EASEMENT LAND COSTS [\$]	CONSTRUCTION COST	
	Length [ft]	Land Class	Instll. Class	Land [\$/ft]	M&I [\$/ft]		Material & Installation [\$]	Appurtenances & Miscellaneous ¹ [\$]
Type 1 - Open	43,621	R	1	53.72	771	2,343,320	33,631,791	909,030
Type 2 - Wooded	19,952	R	2	53.72	786	1,071,821	15,682,272	415,785
Type 3 - Creek Crossings	2,321	R	3	53.72	1211	124,684	2,810,731	48,368
Type 4 - Road/Parking Lot Crossings	126	R	4	53.72	1166	6,769	146,916	2,626
Type 5 - Bore or Tunnel Crossings	200	R	5	53.72	2015	10,744	403,000	4,168
Type 6 - Deep Cut (10-15' cover)	-	R	6	53.72	858	-	-	-
Type 7 - Open Cut With Liner	4,485	R	7	53.72	1436	240,934	6,440,460	93,464
Landowner Count Count ²	47	EA		25000	\$/EA	1,175,000		
Totals:		66,220				\$4,973,273	\$59,115,170	\$1,473,442
							CONSTRUCTION COST	\$60,588,612
							CONTINGENCY 20%	\$12,117,722
							TOTAL CONSTRUCTION COST:	\$72,710,000
							TOTAL LAND COST	\$4,970,000
							TOTAL ROUTE COST	\$77,680,000

1. Appurtenances & Miscellaneous - Includes air valves, blow off valves, butterfly valves, etc.

2. This is for ROE and acquisition related costs



North Texas Municipal Water District

Table 4 – Corridor A2 Cost Analysis

ORIGINAL ALIGNMENT	SEGMENT PARAMETERS			UNIT COSTS		EASEMENT LAND COSTS	CONSTRUCTION COST	
	Type & Description	Length [ft]	Land Class	Instll. Class	Land [\$/ft]		M&I [\$/ft]	Material & Installation [\$]
Type 1- Open	45,160	R	1	53.72	771	2,425,995	34,818,360	941,102
Type 2- Wooded	20,695	R	2	53.72	786	1,111,735	16,266,270	431,269
Type 3 - Creek Crossings	2,132	R	3	53.72	1211	114,531	2,581,852	44,429
Type 4 - Road/Parking Lot Crossings	158	R	4	53.72	1166	8,488	184,228	3,293
Type 5 - Bore or Tunnel Crossings	200	R	5	53.72	2015	10,744	403,000	4,168
Type 6 - Deep Cut (10-15' cover)		R	6	53.72	858	-	-	-
Type 7 - Open Cut With Liner	4,485	R	7	53.72	1436	240,934	6,440,460	93,464
Landowner Count Count ²	56	EA		25000	\$/EA	1,400,000		
Totals:		68,345				\$5,312,428	\$60,694,170	\$1,517,725
							CONSTRUCTION COST	\$62,211,895
							CONTINGENCY 20%	\$12,442,379
							TOTAL CONSTRUCTION COST:	\$74,650,000
							TOTAL LAND COST	\$5,310,000
							TOTAL ROUTE COST	\$79,960,000

1. Appurtenances & Miscellaneous - Includes air valves, blow off valves, butterfly valves, etc.
2. This is for ROE and acquisition related costs

Table 5 – Corridor A2-Aerial Cost Analysis

ORIGINAL ALIGNMENT	SEGMENT PARAMETERS			UNIT COSTS		EASEMENT LAND COSTS	CONSTRUCTION COST	
	Type & Description	Length [ft]	Land Class	Instll. Class	Land [\$/ft]		M&I [\$/ft]	Material & Installation [\$]
Type 1- Open	45,309	R	1	53.72	771	2,433,999	34,933,239	944,207
Type 2- Wooded	20,566	R	2	53.72	786	1,104,806	16,164,876	428,581
Type 3 - Creek Crossings	2,132	R	3	53.72	1211	114,531	2,581,852	44,429
Type 4 - Road/Parking Lot Crossings	138	R	4	53.72	1166	7,413	160,908	2,876
Type 5 - Bore or Tunnel Crossings	200	R	5	53.72	2015	10,744	403,000	4,168
Type 6 - Deep Cut (10-15' cover)		R	6	53.72	858	-	-	-
Type 7 - Open Cut With Liner		R	7	53.72	1436	-	-	-
Type 8 - Aerial Crossing	4,485	R	8	53.72	1436	240,934	6,440,460	93,464
Landowner Count Count ²	56	EA		25000	\$/EA	1,400,000		
Totals:		68,345				\$5,312,428	\$60,684,335	\$1,517,725
							CONSTRUCTION COST	\$62,202,060
							CONTINGENCY 20%	\$12,440,412
							TOTAL CONSTRUCTION COST:	\$74,640,000
							TOTAL LAND COST	\$5,310,000
							TOTAL ROUTE COST	\$79,950,000

1. Appurtenances & Miscellaneous - Includes air valves, blow off valves, butterfly valves, etc.
2. This is for ROE and acquisition related costs



North Texas Municipal Water District

Table 6 – Corridor A3 Cost Analysis

ORIGINAL ALIGNMENT	SEGMENT PARAMETERS			UNIT COSTS		EASEMENT LAND COSTS	CONSTRUCTION COST	
	Type & Description	Length [ft]	Land Class	Instll. Class	Land [\$/ft]		M&I [\$/ft]	Material & Installation [\$]
Type 1 - Open	56,100	R	1	53.72	771	3,013,692	43,253,100	1,169,084
Type 2 - Wooded	12,916	R	2	53.72	786	693,848	10,151,976	269,160
Type 3 - Creek Crossings	518	R	3	53.72	1211	27,827	627,298	10,795
Type 4 - Road/Parking Lot Crossings	151	R	4	53.72	1166	8,112	176,066	3,147
Type 5 - Bore or Tunnel Crossings	200	R	5	53.72	2015	10,744	403,000	4,168
Type 6 - Deep Cut (10-15' cover)		R	6	53.72	858	-	-	-
Type 7 - Open Cut With Liner	4,485	R	7	53.72	1436	240,934	6,440,460	93,464
Landowner Count Count ²	54	EA		25000	\$/EA	1,350,000		
Totals:		69,885				\$5,345,156	\$61,051,900	\$1,549,818
							CONSTRUCTION COST	\$62,601,718
							CONTINGENCY 20%	\$12,520,344
							TOTAL CONSTRUCTION COST:	\$75,120,000
							TOTAL LAND COST	\$6,350,000
							TOTAL ROUTE COST	\$80,470,000

1. Appurtenances & Miscellaneous - Includes air valves, blow off valves, butterfly valves, etc.
 2. This is for ROE and acquisition related costs

Table 7 – Corridor A1-A3 Cost Analysis

ORIGINAL ALIGNMENT	SEGMENT PARAMETERS			UNIT COSTS		EASEMENT LAND COSTS	CONSTRUCTION COST	
	Type & Description	Length [ft]	Land Class	Instll. Class	Land [\$/ft]		M&I [\$/ft]	Material & Installation [\$]
Type 1 - Open	55,017	R	1	53.72	771	2,955,513	42,418,107	1,146,515
Type 2 - Wooded	12,144	R	2	53.72	786	652,376	9,545,184	253,072
Type 3 - Creek Crossings	518	R	3	53.72	1211	27,827	627,298	10,795
Type 4 - Road/Parking Lot Crossings	131	R	4	53.72	1166	7,037	152,746	2,730
Type 5 - Bore or Tunnel Crossings	225	R	5	53.72	2015	12,087	453,375	4,689
Type 6 - Deep Cut (10-15' cover)		R	6	53.72	858	-	-	-
Type 7 - Open Cut With Liner	4,485	R	7	53.72	1436	240,934	6,440,460	93,464
Landowner Count Count ²	45	EA		25000	\$/EA	1,125,000		
Totals:		68,035				\$5,020,774	\$59,637,170	\$1,511,265
							CONSTRUCTION COST	\$61,148,435
							CONTINGENCY 20%	\$12,229,687
							TOTAL CONSTRUCTION COST:	\$73,380,000
							TOTAL LAND COST	\$5,020,000
							TOTAL ROUTE COST	\$78,400,000

1. Appurtenances & Miscellaneous - Includes air valves, blow off valves, butterfly valves, etc.
 2. This is for ROE and acquisition related costs



North Texas Municipal Water District

Table 8 – Corridor A1-A3A Cost Analysis

ORIGINAL ALIGNMENT	SEGMENT PARAMETERS			UNIT COSTS		EASEMENT LAND COSTS	CONSTRUCTION COST	
	Type & Description	Length [ft]	Land Class	Instll. Class	Land [\$/ft]		M&I [\$/ft]	Material & Installation [\$]
Type 1 - Open	54,616	R	1	53.72	771	2,933,972	42,108,936	1,138,158
Type 2 - Wooded	13,343	R	2	53.72	786	716,786	10,487,598	278,059
Type 3 - Creek Crossings	518	R	3	53.72	1211	27,827	627,298	10,795
Type 4 - Road/Parking Lot Crossings	128	R	4	53.72	1166	6,876	149,248	2,667
Type 5 - Bore or Tunnel Crossings	225	R	5	53.72	2015	12,087	453,375	4,689
Type 6 - Deep Cut (10-15' cover)		R	6	53.72	858	-	-	-
Type 7 - Open Cut With Liner	3,677	R	7	53.72	1436	197,528	5,280,172	76,626
Landowner Count Count ²	48	EA		25000	\$/EA	1,200,000		
Totals:		68,830				\$5,095,076	\$59,106,627	\$1,510,994
							CONSTRUCTION COST	\$60,617,621
							CONTINGENCY 20%	\$12,123,524
							TOTAL CONSTRUCTION COST:	\$72,740,000
							TOTAL LAND COST	\$5,100,000
							TOTAL ROUTE COST	\$77,840,000

1. Appurtenances & Miscellaneous - includes air valves, blow off valves, butterfly valves, etc.
2. This is for ROE and acquisition related costs

Table 9 – Corridor B Cost Analysis

ORIGINAL ALIGNMENT	SEGMENT PARAMETERS			UNIT COSTS		EASEMENT LAND COSTS	CONSTRUCTION COST	
	Type & Description	Length [ft]	Land Class	Instll. Class	Land [\$/ft]		M&I [\$/ft]	Material & Installation [\$]
Type 1 - Open	60,406	R	1	53.72	771	3,245,010	46,573,026	1,258,818
Type 2 - Wooded	16,857	R	2	53.72	786	905,558	13,249,602	351,288
Type 3 - Creek Crossings	1,165	R	3	53.72	1211	62,584	1,410,815	24,278
Type 4 - Road/Parking Lot Crossings	196	R	4	53.72	1166	10,529	228,536	4,085
Type 5 - Bore or Tunnel Crossings	225	R	5	53.72	2015	12,087	453,375	4,689
Type 6 - Deep Cut (10-15' cover)		R	6	53.72	858	-	-	-
Type 7 - Open Cut With Liner		R	7	53.72	1436	-	-	-
Landowner Count ²	62	EA		25000	\$/EA	1,550,000		
Totals:		78,849				\$5,785,768	\$61,915,354	\$1,643,157
							CONSTRUCTION COST	\$63,558,511
							CONTINGENCY 20%	\$12,711,702
							TOTAL CONSTRUCTION COST:	\$76,270,000
							TOTAL LAND COST	\$5,790,000
							TOTAL ROUTE COST	\$82,060,000

1. Appurtenances & Miscellaneous - includes air valves, blow off valves, butterfly valves, etc.
2. This is for ROE and acquisition related costs

2.0 PIPELINE ALIGNMENT

2.1 SECTION A - NORTH

2.1.1 Introduction

Section A of the LBCR Raw Water Pipeline project was split into two portions, because the location of the LBCR pump station was yet to be determined during preliminary phases of the pipeline alignment analysis. It was determined the southern portion of Section A would be common to both pump station locations being considered and therefore could be analyzed before the pump station location was determined. However, the northern portion of Section A was dependent on the pump station location and thus the alignment evaluation was postponed until the pump station location was determined in the meeting held on April 24, 2013. The dividing point between the southern and northern alignment studies is FM 1743, which is slightly south of US 82. The end point of the southern alignment study for Section A is the proposed connection to LBCR Pipeline



Figure 4 – Evaluated Corridor

Section B located at SH 56. The northern portion of Section A is approximately 11.1 miles and begins by heading southeast around the Honey Grove Arm of the reservoir before heading southwest to the beginning of the southern portion of Section A at FM 1743.

North Texas Municipal Water District

The analysis described below was used to determine the recommended alignment for the northern portion of the LBCR Pipeline Section A alignment. The southern portion of Section A was presented in the "Pipeline Alignment Selection Memorandum" dated 19 July 2013 and was accepted by NTMWD at the Alignment review meeting that took place on 8 August 2013. The Technical Memorandum for the southern portion of Section A has been incorporated in this PDR as **Section 2.2**. The following general parameters were adopted to generate acceptable alignments, from the preliminary alignment corridor, for analysis: avoid or minimize environmental permitting potential, align beginning with the proposed Pump Station site and ending with the beginning of the southern portion of Section A, minimize pipeline length where it does not impact other parameters, minimize impact to landowners along route, minimize constructability concerns, and avoid significant terrain that negatively affects hydraulics.



Figure 5 – Overall Segment A – North Alignments

2.1.2 Evaluation of Corridors

The corridor which these alternates are based on is presented in red on **Figure 4** and was originally presented in the "Pipeline Section A Corridor Selection Technical Memorandum" dated June 28, 2013 and incorporated in this PDR as **Section 1.0 – Corridor Study – Section A North of US 82**.

2.1.3 Route Alternatives

The northern Section A corridor was analyzed in further detail to identify conflicts and develop

North Texas Municipal Water District

alignment alternatives. Conflict areas were determined based upon aerial imagery and field work. Initial conflict development revealed five conflict areas and are shown in **Figure 5**. The five conflict areas are labeled in descending order from North to South starting at six and going to two. These conflict areas were numbered from South to North in order to keep the numbers in sequence with the established conflict area of the southern portion of Section A. For purposes of this discussion we will cover the conflict areas from North to South which will be in descending order. The reason for covering them from North to South is because this is the order the other sections have used during analysis of their conflict areas.

Figures 5-10 all have a consistent color scheme to show each alternate for the individual conflict areas. The original alignment corridor centerline is shown in blue for each conflict area figure and described as Alternate A in this memorandum. The rest of the alternates are shown in the figures as follows; Alternate B's are magenta, Alternate C's are teal and Alternate D's are pink.

Conflict Area #6 is a house and barn that is directly north of a densely wooded area. Conflict Area #5 is a confluence of several creeks which will form a small finger of LBCR. Conflict Area #4 is a large conflict area that involves avoiding two large stock ponds and crossing an Oncor Electrical Transmission Line and a meandering Honey Grove Creek. Conflict Area #3 is a diversion around a small stock pond and associated creek drainage area along with a 10" Atmos Gas Line that will be crossed in this area. Conflict Area #2 is a tight cluster of buildings that includes two homes, several small sheds and two barn structures. The rest of the terrain in this corridor consists of primarily open and cultivated land with all possible alignment alternatives sharing three major creek crossings. The alignments shown have had an initial field environmental study performed and there are no anticipated wetland concerns. From the localized analysis of each conflict area, alignment alternatives were developed.

The preferred alternative was determined by analysis that compared the total length, number of parcels affected, open cut length, wooded length, tunnel length, construction cost, and land acquisition cost. The recommended alignment was chosen based on the overall cost analysis and engineering judgment. The detailed route analysis of these alignment alternatives is discussed below.

2.1.4 Detailed Route Analysis

Installation cost factors were developed to take into account the varying costs of pipeline construction through different land classifications. Cost data was updated in order to closely coincide with recent bid

North Texas Municipal Water District

information. Routes were classified by the type of land in which they would be installed: open, wooded, open cut creek crossings, open cut road crossings, or tunneled crossings. A construction cost and land acquisition cost was associated with each classification in order to estimate the total route cost per linear foot. This allowed a cost to be generated for each alternate based upon the linear footage of the land classification. From this, a cost comparison was performed for the alternates in order to determine the most cost effective route.

Conflict Area #6 was identified because of the close proximity of two homesteads to a densely wooded area along CR 2730. The two homesteads are located to the north and south of the densely wooded area and both include uninhabited structures as well

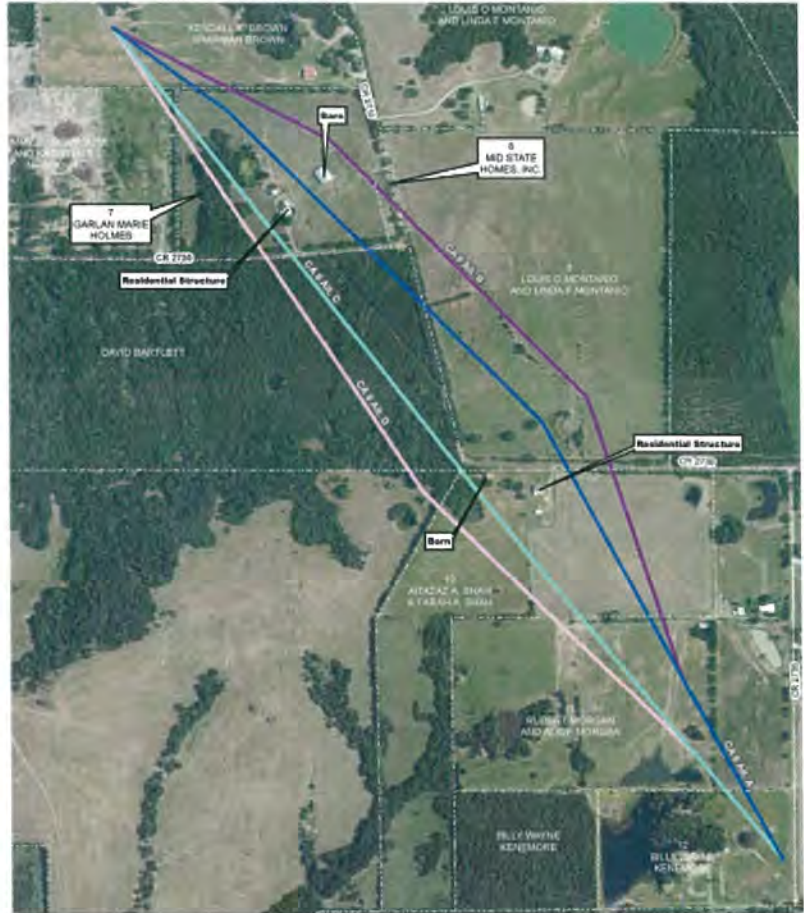

Figure 6 – Aerial View of Conflict Area #6

as small ponds. The densely wooded area also has several ponds visible from aerial imagery. Four alternatives have been proposed to provide a compromise between landowner impact, constructability, and cost. All of the alternatives diverge at the same point approximately 1300 feet northwest of the house that is north of the densely wooded area. Alternate A was the original centerline of the preliminary alignment corridor and provides a compromise between going around the homes and wooded area or going through the wooded area west of CR 2710. Alternate B was developed to provide a route that avoids the conflict area. Alternate C was developed to show a straight line between the limits of the conflict area. Alternate D shows a slight bend in order to provide adequate spacing from the existing ponds. Conflict Area #6 and the four alternatives can be seen in Figure 6.

North Texas Municipal Water District

All of the alternates are similar in cost. Only \$150K separates all of the options, as shown in **Table 10** below. Alternates C and D are the two least expensive options but they cross through over 2,000 feet of forested land. While Alternate A eliminates two-thirds of the wooded crossing, it comes within 150 feet of the homes to the north and south of the densely wooded area. Alternate B is the most expensive but it also has the least amount of pipe in a wooded area and allows for more space between the pipeline and the homes in this conflict while affecting the least amount of parcels. Alternate B is the preferred alignment because it minimizes environmental and land owner impact.

Table 10 – Analysis for Conflict Area #6

Option	Alternate A	Alternate B	Alternate C	Alternate D
Length (ft.)	5,944	6,121	5,873	5,902
Number of Parcels	7	7	8	8
Open Length (ft.)	5,153	5,898	3,759	3,786
Wooded Length (ft.)	791	223	2,114	2,116
Tunnel/Bore Length	0	0	0	0
Construction Cost	\$ 4,880,000	\$ 5,000,000	\$ 4,830,000	\$ 4,860,000
Land Acquisition Cost	\$ 490,000	\$ 500,000	\$ 520,000	\$ 500,000
Total Cost	\$ 5,370,000	\$ 5,500,000	\$ 5,350,000	\$ 5,360,000

*For further cost analysis data see **Tables 30-33**.

Conflict Area #5 is the confluence of several branches of Fox Creek as well as a small finger of LBCR. Due to environmental and constructability concerns, proceeding directly through the creek confluence was not considered within the alignment options. Four alternatives were developed for proceeding through this conflict area. Alternate A crosses a small finger of LBCR slightly west and downstream of the Fox Creek Confluence. Alternate B swings east of the Fox Creek Confluence and the finger of LBCR. Alternate C was developed to provide a shorter alternative that also traveled east around the Fox Creek Confluence and finger of LBCR. Alternate D takes a more direct route closely hugging the Fox Creek Confluence then continuing in open land as oppose to forested land as shown for Alternates B and C. Conflict Area #5 and the four alternatives can be seen in **Figure 7** to the right.



Figure 7 – Aerial View of Conflict Area #5

North Texas Municipal Water District

All of the alternates cross Fox Creek. Alternate A is the shortest most direct route to navigate this conflict and therefore the least expensive. It also goes through less wooded areas than the other three alternates; however, it crosses under approximately 500 feet of LBCR when it is at the 534 foot pool elevation. All of the other alternates are similar in cost as shown in **Table 11** on the next page and have multiple creek crossings because they cross upstream of the Fox Creek Confluence. Alternate A is the preferred route through this conflict area because it minimizes the number of creek crossings, parcels and has the lowest cost.

Table 11 – Analysis for Conflict Area #5

Option	Alternate A	Alternate B	Alternate C	Alternate D
Length (ft.)	10,198	10,700	10,673	10,609
Number of Parcels	4	5	5	6
Open Length (ft.)	8,279	7,328	7,327	8,028
Wooded Length (ft.)	1,923	3,372	3,346	2,581
Tunnel/Bore Length	0	0	0	0
Construction Cost	\$ 8,570,000	\$ 8,85,000	\$ 8,840,000	\$ 8,800,000
Land Acquisition Cost	\$ 260,000	\$ 430,000	\$ 410,000	\$ 360,000
Total Cost	\$ 8,830,000	\$ 9,280,000	\$ 9,250,000	\$ 9,160,000

*For further cost analysis data see **Tables 26-29**.

Conflict Area #4 was identified because of two large private ponds that are in close proximity to each other. This conflict area is very large due to the Honey Grove Creek Confluence near the northern boundary of this conflict area and the string of four houses along CR 2765 that are in the immediate area of the two large ponds near the southern boundary of this conflict area. Four alternatives have been proposed to traverse this conflict area. Alternate A crosses Honey Grove Creek downstream of the confluence and then cuts through open land offset from a tributary by 180 feet at its closest point until crossing between a house and the northernmost pond. Alternate B closely parallels Alternate A to the North hugging CR 2765 at a slight bend to squeeze between a mobile home and the road. Alternate C goes farther south and crosses in between the two ponds. Alternate D is an off shoot of Alternate B providing a route around the mobile home and a house to the North. Conflict Area #4 and the four alternatives can be seen in **Figure 8**.

North Texas Municipal Water District

All of the alternates in this conflict will cross Honey Grove Creek, an Onconr Transmission Corridor and two County Roads. Due to the high steep banks of Honey Grove Creek in the area that all of these alignments cross the creek, the pipeline would be installed by bore or tunnel to cross Honey Grove Creek. Alternate C is the longest and most expensive option as it travels upstream and south of the Honey Grove Creek Confluence. This allows it to cross smaller creeks and stay on a ridge line between the

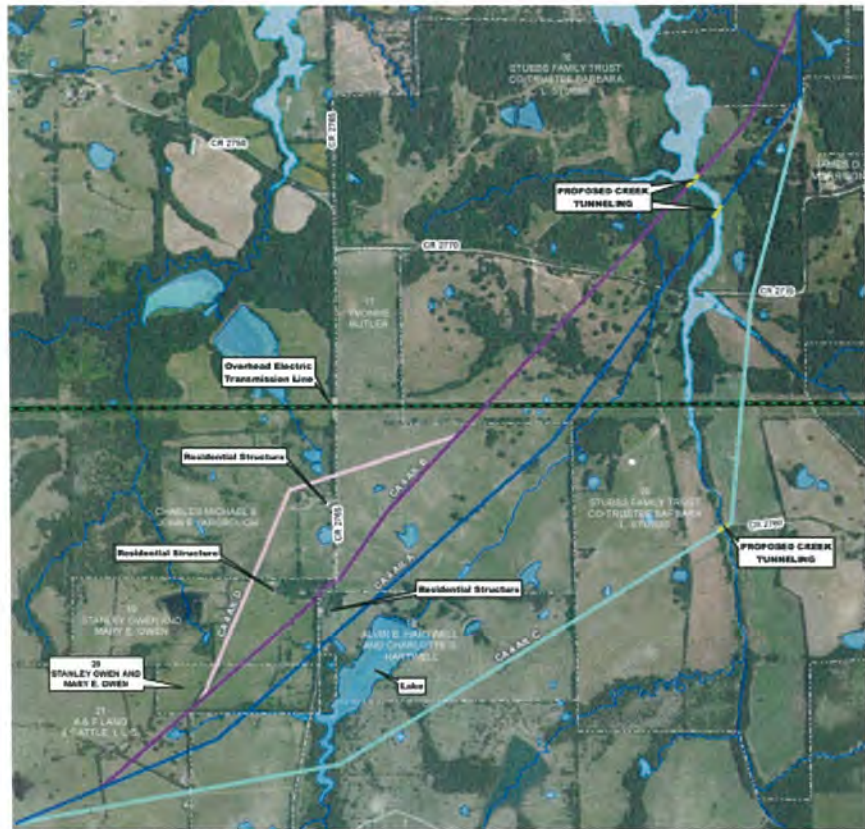

Figure 8 – Aerial View of Conflict Area #4

two large ponds near CR 2765. Alternates A, B and D follow similar paths crossing Honey Grove Creek downstream of the confluence. Alternate A then follows a tributary of Honey Grove Creek before it crosses in between the northern large pond and a home. It is approximately 140 feet from both the home and the water's edge. Alternate B is the shortest and least expensive route. As it crosses CR 2765 it passes in between two homes, 120 feet from a mobile home and 200 feet from a house. Alternate D follows Alternate B with the exception of the crossing of CR 2765. Alternate D goes around the homes that Alternate B splits which causes Alternate D to be slightly longer. **Table 12** details each alternate below. Alternate B is the preferred route through this conflict area because it is not only the least expensive but also minimizes landowner impact and length of pipe in wooded land.

Table 12 – Analysis for Conflict Area #4

Option	Alternate A	Alternate B	Alternate C	Alternate D
Length (ft.)	13,347	13,006	14,826	13,395
Number of Parcels	7	6	5	6
Open Length (ft.)	10,073	10,204	6,611	10,692
Wooded Length (ft.)	3,079	2,592	8,095	2,493
Tunnel/Bore Length	195	210	120	210
Construction Cost	\$ 11,270,000	\$ 11,020,000	\$ 12,510,000	\$ 11,330,000
Land Acquisition Cost	\$ 830,000	\$ 780,000	\$ 860,000	\$ 800,000
Total Cost	\$ 12,100,000	\$ 11,800,000	\$ 13,370,000	\$ 12,130,000

*For further cost analysis data see **Tables 22-25**.

Conflict Area #3 was identified because of a stock pond that feeds a small creek and there is also 10" Atmos gas line that runs east-west in this area. Two alternatives have been proposed to travel around this conflict area. Alternate A travels to the north of the pond and creek. Alternate B heads south around the pond and creek. Conflict Area #3 and the two alternatives can be seen in **Figure 9** below.



Figure 9 – Aerial View of Conflict Area #3

Both alternates will cross Ward Creek and the 10" Atmos gas line. The crossing of Ward Creek will be installed by bore or tunnel. This is due to the steep banks of Ward Creek. Alternate B heads south of the pond and then parallels the Atmos gas line until shortly after crossing Ward Creek. Alternate A stays north of the pond and is least expensive option and our preferred route, for specific numbers see **Table 13** below.

Table 13 – Analysis for Conflict Area #3

Option	Alternate A	Alternate B
Length (ft.)	5,469	5,691
Number of Parcels	5	6
Open Length (ft.)	4,075	5,013
Wooded Length (ft.)	1,294	578
Tunnel/Bore Length	100	100
Construction Cost	\$ 4,610,000	\$ 4,780,000
Land Acquisition Cost	\$ 420,000	\$ 460,000
Total Cost	\$ 5,030,000	\$ 5,240,000

*For further cost analysis data see **Tables 20 & 21**.

Conflict Area #2 consists of two homesteads that are very close to each other. This conflict area includes two houses as well as a barn and several sheds. Three alternatives were developed for this conflict area. Alternate A goes south around the cluster of buildings while Alternate C goes north around the cluster of buildings. Alternate B also goes south around the houses but it is a more direct route than Alternate A. Conflict Area #2 and the three alternatives can be seen in **Figure 10**.



Figure 10 – Aerial View of Conflict Area #2

Alternate C is the longest and most expensive alternate and also crosses a small creek which the other two alternates do not. Alternate B is the least expensive option as it is the shortest route. Alternate B's direct route does encounter two small drainage features that may present maintenance concerns as the scours in the drainage features change after construction. One drainage feature is an old borrow pit that has had a channel scoured out over time connecting it to a small pond to the north. The other drainage feature is an erosion area that has scoured out over time but does not seem to drain to a distinguishable water body. Alternate A is slightly longer and more expensive than Alternate B, for specific numbers see **Table 14**. Alternate A however avoids one of the erosion areas that Alternate B travels through and it passes through a smaller section of the borrow pit than Alternate B.

Table 14 – Analysis for Conflict Area #2

Option	Alternate A	Alternate B	Alternate C
Length (ft.)	5,310	5,235	5,485
Number of Parcels	3	3	3
Open Length (ft.)	5,145	5,055	5,055
Wooded Length (ft.)	165	180	430
Tunnel/Bore Length	0	0	0
Construction Cost	\$ 4,350,000	\$ 4,280,000	\$ 4,500,000
Land Acquisition Cost	\$ 360,000	\$ 360,000	\$ 370,000
Total Cost	\$ 4,710,000	\$ 4,640,000	\$ 4,870,000

*For further cost analysis data see **Tables 17-19**.



North Texas Municipal Water District

2.1.5 Opinion of Probable Construction Cost

The Opinion of Probable Construction Cost (OPCC) for the northern portion of the Section A recommended alignment as described above is \$60,653,050. A detailed breakdown of the OPCC for the preferred alignment is shown in **Table 15** below.

Table 15 – Opinion of Probable Construction Costs

NTMWD Lower Bois d'Arc Creek Reservoir Raw Water Pipeline		FREESE NICHOLS AND ASSOCIATES		1701 N Market St., #500, L051 • Dallas, Texas 75202 • 214-217-2200 • fax 214-217-2201		www.Freeze.com		
OPINION OF PROBABLE CONSTRUCTION COSTS (INCLUDING EASEMENTS)							November 26, 2013	
ESTIMATOR WRS				CHECKED BY ASM		ACCOUNT NO NTD13136		
ITEM	DESCRIPTION	QUANTITY	UNIT	UNIT PRICE	TOTAL			
1	50-INCH PIPELINE	58,005	LF	\$650.00	\$	37,703,250		
2	TUNNELED CROSSINGS	230	LF	\$1,970.00	\$	453,100		
3	PIPELINE ROW CLEARING	160	AC	\$5,000.00	\$	800,000		
4	TRENCH SAFETY	58,005	LF	\$1.00	\$	58,005		
5	AIR RELEASE VALVES	17	EA	\$25,000.00	\$	415,000		
6	BUTTERFLY VALVES	2	EA	\$165,000.00	\$	330,000		
7	BLOW OFF VALVES	17	EA	\$25,000.00	\$	415,000		
8	PAVEMENT RESTORATION	940	SY	\$70.00	\$	65,800		
9	CREEK CROSSINGS	1,053	LF	\$445.00	\$	468,585		
10	REVEGETATION	160	AC	\$1,160.00	\$	185,600		
11	FIBER OPTIC CONDUIT	58,235	LF	\$3.00	\$	174,705		
12	FIBER	58,235	LF	\$2.00	\$	116,470		
13	CATHODIC PROTECTION	58,235	LF	\$2.00	\$	116,470		
14	ACCESS MAINWAYS	17	EA	\$10,000.00	\$	166,000		
15	TESTING	58,235	LF	\$2.00	\$	116,470		
16	MOBILIZATION	1	LS	\$2,079,223.00	\$	2,079,223		
CONSTRUCTION SUBTOTAL					\$	43,665,080		
CONSTRUCTION CONTINGENCY					13%	\$	5,549,800	
CONSTRUCTION TOTAL					\$	49,214,880		
ESTIMATED EASEMENT/PROPERTY COSTS								
PERMANENT EASEMENT W/ ASSOCIATED TEMPORARY ¹					2,188,500	SF	\$1.00	\$2,188,500.00
TOTAL ESTIMATED COSTS (INCLUDING EASEMENT)					\$	\$52,397,900.00		

1. Estimated Easement Costs Based on a 50' Perm Easement & 70' Temp Easement for Section A Northern Portion excluding easement on NTMWD land

North Texas Municipal Water District

2.1.6 Recommendation Summary

The recommended alignment for Section A is Alternate A for Conflict Area #2, #3 and #5 and Alternate B for Conflict Area #4 and #6. Although not all options are the least expensive, all of the routes were chosen based on a balance between landowner impact, constructability and cost. Based on the recommended routes the total length of the preferred alignment for the northern portion of Section A is 11.07 miles.

2.1.7 Pipeline Crossings

Table 16 presents identified utility, roadway, and creek crossings associated with the recommended route.

Table 16 – Major Transportation, Utility, and Creek Crossings

Road
Fannin CR 2725
CR 2710
CR 2730
CR 2735
CR 2770
CR 2765
Farm to Market 1396
CR 2992
United States Route 82
CR 2989
Farm to Market 1793
Utility
Oncor Overhead Electric Transmission Lines
Atmos 10" Gas Distribution Line
Waterbody
Tributary of Honey Grove Creek
LBCR Finger (Fox Creek)
Tributary of Honey Grove Creek (2)
Honey Grove Creek
Tributary of Honey Grove Creek
Allen's Creek
Tributary of Allen's Creek (2)
Tributary of Ward Creek
Ward Creek



North Texas Municipal Water District

Table 17 - Conflict Area #2 Alt A Cost Analysis

ORIGINAL ALIGNMENT Type & Description	SEGMENT PARAMETERS			UNIT COSTS		EASEMENT LAND COSTS [\$]	CONSTRUCTION COST		
	Length [ft]	Land Class	Instll. Class	Land [\$/ft]	M&I [\$/ft]		Material & Installation [\$]	& Miscellaneous 1 [\$]	
Type 1- Open	5,125	R	1	53.72	656	275,315	3,362,000	106,801	
Type 2- Wooded	125	R	2	53.72	669	6,715	83,625	2,605	
Type 3 - Creek Crossings	40	R	3	53.72	1094	2,149	43,760	834	
Type 4 - Road/Parking Lot Crossings	20	R	4	53.72	1047	1,074	20,940	417	
Type 5 - Bore or Tunnel Crossings		R	5	53.72	1900	-	-	-	
Type 6 - Deep Cut (10-15' cover)		R	6	53.72	735	-	-	-	
NTMWD Easement Land Cost Reduction ²		R		53.72		-	-	-	
Parcel Count ³	3	EA		25000	\$/EA	75,000			
Totals:						5,310	\$360,253	\$3,510,325	\$110,657
							CONSTRUCTION COST	\$3,620,982	
							CONTINGENCY 20%	\$724,196	
							TOTAL CONSTRUCTION COST:	\$4,350,000	
							TOTAL LAND COST	\$360,000	
							TOTAL ROUTE COST	\$4,710,000	

1. Appurtenances & Miscellaneous - Includes air valves, blow off valves, butterfly valves, etc.
2. This is for easements that will be required on NTMWD owned land
3. This is for ROE and acquisition related costs - NTMWD parcels crossed are not included in this amount

Table 18 - Conflict Area #2 Alt B Cost Analysis

ORIGINAL ALIGNMENT Type & Description	SEGMENT PARAMETERS			UNIT COSTS		EASEMENT LAND COSTS [\$]	CONSTRUCTION COST		
	Length [ft]	Land Class	Instll. Class	Land [\$/ft]	M&I [\$/ft]		Material & Installation [\$]	& Miscellaneous 1 [\$]	
Type 1- Open	5,035	R	1	53.72	656	270,480	3,302,960	104,926	
Type 2- Wooded	150	R	2	53.72	669	8,058	100,350	3,126	
Type 3 - Creek Crossings	30	R	3	53.72	1094	1,612	32,820	625	
Type 4 - Road/Parking Lot Crossings	20	R	4	53.72	1047	1,074	20,940	417	
Type 5 - Bore or Tunnel Crossings		R	5	53.72	1900	-	-	-	
Type 6 - Deep Cut (10-15' cover)		R	6	53.72	735	-	-	-	
NTMWD Easement Land Cost Reduction ²		R		53.72		-	-	-	
Parcel Count ³	3	EA		25000	\$/EA	75,000			
Totals:						5,235	\$356,224	\$3,457,070	\$109,094
							CONSTRUCTION COST	\$3,566,164	
							CONTINGENCY 20%	\$713,233	
							TOTAL CONSTRUCTION COST:	\$4,280,000	
							TOTAL LAND COST	\$360,000	
							TOTAL ROUTE COST	\$4,640,000	

1. Appurtenances & Miscellaneous - Includes air valves, blow off valves, butterfly valves, etc.
2. This is for easements that will be required on NTMWD owned land
3. This is for ROE and acquisition related costs - NTMWD parcels crossed are not included in this amount



North Texas Municipal Water District

Table 19 - Conflict Area #2 Alt C Cost Analysis

ORIGINAL ALIGNMENT Type & Description	SEGMENT PARAMETERS			UNIT COSTS		EASEMENT LAND COSTS [\$]	CONSTRUCTION COST	
	Length [ft]	Land Class	Instll. Class	Land [\$/ft]	M&I [\$/ft]		Material & Installation [\$]	& Miscellaneous 1 [\$]
Type 1- Open	5,015	R	1	53.72	656	269,406	3,289,840	104,509
Type 2- Wooded	390	R	2	53.72	669	20,951	260,910	8,127
Type 3 - Creek Crossings	40	R	3	53.72	1094	2,149	43,760	834
Type 4 - Road/Parking Lot Crossings	40	R	4	53.72	1047	2,149	41,880	834
Type 5 - Bore or Tunnel Crossings		R	5	53.72	1900	-	-	-
Type 6 - Deep Cut (10-15' cover)		R	6	53.72	735	-	-	-
NTMWD Easement Land Cost Reduction ²		R		53.72		-	-	-
Parcel Count ³	3	EA		25000	\$/EA	75,000		
Totals:		5,485				\$369,654	\$3,636,390	\$114,303
						CONSTRUCTION COST	\$3,750,693	
						CONTINGENCY 20%	\$750,139	
						TOTAL CONSTRUCTION COST:	\$4,500,000	
						TOTAL LAND COST	\$370,000	
						TOTAL ROUTE COST	\$4,870,000	

1. Appurtenances & Miscellaneous - Includes air valves, blow off valves, butterfly valves, etc.
2. This is for easements that will be required on NTMWD owned land
3. This is for ROE and acquisition related costs - NTMWD parcels crossed are not included in this amount

Table 20 - Conflict Area #3 Alt A Cost Analysis

ORIGINAL ALIGNMENT Type & Description	SEGMENT PARAMETERS			UNIT COSTS		EASEMENT LAND COSTS [\$]	CONSTRUCTION COST	
	Length [ft]	Land Class	Instll. Class	Land [\$/ft]	M&I [\$/ft]		Material & Installation [\$]	& Miscellaneous 1 [\$]
Type 1- Open	4,070	R	1	53.72	656	218,640	2,669,920	84,816
Type 2- Wooded	1,299	R	2	53.72	669	69,782	869,031	27,070
Type 3 - Creek Crossings	-	R	3	53.72	1094	-	-	-
Type 4 - Road/Parking Lot Crossings		R	4	53.72	1047	-	-	-
Type 5 - Bore or Tunnel Crossings	100	R	5	53.72	1900	5,372	190,000	2,084
Type 6 - Deep Cut (10-15' cover)		R	6	53.72	735	-	-	-
NTMWD Easement Land Cost Reduction ²		R		53.72		-	-	-
Parcel Count ³	5	EA		25000	\$/EA	125,000		
Totals:		5,469				\$418,795	\$3,728,951	\$113,970
						CONSTRUCTION COST	\$3,842,921	
						CONTINGENCY 20%	\$768,584	
						TOTAL CONSTRUCTION COST:	\$4,610,000	
						TOTAL LAND COST	\$420,000	
						TOTAL ROUTE COST	\$5,030,000	

1. Appurtenances & Miscellaneous - Includes air valves, blow off valves, butterfly valves, etc.
2. This is for easements that will be required on NTMWD owned land
3. This is for ROE and acquisition related costs - NTMWD parcels crossed are not included in this amount



North Texas Municipal Water District

Table 21 - Conflict Area #3 Alt B Cost Analysis

ORIGINAL ALIGNMENT Type & Description	SEGMENT PARAMETERS			UNIT COSTS		EASEMENT LAND COSTS [\$]	CONSTRUCTION COST	
	Length [ft]	Land Class	Instll. Class	Land [\$/ft]	M&I [\$/ft]		Material & Installation [\$]	& Miscellaneous 1 [\$]
Type 1 - Open	4,983	R	1	53.72	656	267,687	3,268,848	103,842
Type 2 - Wooded	608	R	2	53.72	669	32,662	406,752	12,670
Type 3 - Creek Crossings	-	R	3	53.72	1094	-	-	-
Type 4 - Road/Parking Lot Crossings		R	4	53.72	1047	-	-	-
Type 5 - Bore or Tunnel Crossings	100	R	5	53.72	1900	5,372	190,000	2,084
Type 6 - Deep Cut (10-15' cover)		R	6	53.72	735	-	-	-
NTMWD Easement Land Cost Reduction ²		R		53.72		-	-	-
Parcel Count ³	6	EA		25000	\$/EA	150,000		
Totals:		5,691				\$455,721	\$3,865,600	\$118,596
							CONSTRUCTION COST	\$3,984,196
							CONTINGENCY 20%	\$796,839
							TOTAL CONSTRUCTION COST:	\$4,780,000
							TOTAL LAND COST	\$460,000
							TOTAL ROUTE COST	\$5,240,000
<p>1. Appurtenances & Miscellaneous - Includes air valves, blow off valves, butterfly valves, etc.</p> <p>2. This is for easements that will be required on NTMWD owned land</p> <p>3. This is for ROE and acquisition related costs - NTMWD parcels crossed are not included in this amount</p>								

Table 22 - Conflict Area #4 Alt A Cost Analysis

ORIGINAL ALIGNMENT Type & Description	SEGMENT PARAMETERS			UNIT COSTS		EASEMENT LAND COSTS [\$]	CONSTRUCTION COST	
	Length [ft]	Land Class	Instll. Class	Land [\$/ft]	M&I [\$/ft]		Material & Installation [\$]	& Miscellaneous 1 [\$]
Type 1 - Open	10,073	R	1	53.72	656	541,122	6,607,888	209,914
Type 2 - Wooded	2,901	R	2	53.72	669	155,842	1,940,769	60,455
Type 3 - Creek Crossings	138	R	3	53.72	1094	7,413	150,972	2,876
Type 4 - Road/Parking Lot Crossings	40	R	4	53.72	1047	2,149	41,880	834
Type 5 - Bore or Tunnel Crossings	195	R	5	53.72	1900	10,475	370,500	4,064
Type 6 - Deep Cut (10-15' cover)		R	6	53.72	735	-	-	-
NTMWD Easement Land Cost Reduction ²	1,104	R		53.72		(59,307)	-	-
Parcel Count ³	7	EA		25000	\$/EA	175,000		
Totals:		13,347				\$832,694	\$9,112,009	\$278,142
							CONSTRUCTION COST	\$9,390,151
							CONTINGENCY 20%	\$1,878,030
							TOTAL CONSTRUCTION COST:	\$11,270,000
							TOTAL LAND COST	\$830,000
							TOTAL ROUTE COST	\$12,100,000
<p>1. Appurtenances & Miscellaneous - Includes air valves, blow off valves, butterfly valves, etc.</p> <p>2. This is for easements that will be required on NTMWD owned land</p> <p>3. This is for ROE and acquisition related costs - NTMWD parcels crossed are not included in this amount</p>								



North Texas Municipal Water District

Table 23 - Conflict Area #4 Alt B Cost Analysis

ORIGINAL ALIGNMENT Type & Description	SEGMENT PARAMETERS			UNIT COSTS		EASEMENT LAND COSTS [\$]	CONSTRUCTION COST	
	Length [ft]	Land Class	Instll. Class	Land [\$/ft]	M&I [\$/ft]		Material & Installation [\$]	& Miscellaneous 1 [\$]
Type 1 - Open	10,204	R	1	53.72	656	548,159	6,693,824	212,644
Type 2 - Wooded	2,392	R	2	53.72	669	128,498	1,600,248	49,848
Type 3 - Creek Crossings	160	R	3	53.72	1094	8,595	175,040	3,334
Type 4 - Road/Parking Lot Crossings	40	R	4	53.72	1047	2,149	41,880	834
Type 5 - Bore or Tunnel Crossings	210	R	5	53.72	1900	11,281	399,000	4,376
Type 6 - Deep Cut (10-15' cover)		R	6	53.72	735	-	-	-
NTMWD Easement Land Cost Reduction ²	1,229	R		53.72		(66,022)	-	-
Parcel Count ³	6	EA		25000	\$/EA	150,000		
Totals:		13,006				\$782,660	\$8,909,992	\$271,036
							CONSTRUCTION COST	\$9,181,028
							CONTINGENCY 20%	\$1,836,206
							TOTAL CONSTRUCTION COST:	\$11,020,000
							TOTAL LAND COST	\$780,000
							TOTAL ROUTE COST	\$11,800,000
<p>1. Appurtenances & Miscellaneous - Includes air valves, blow off valves, butterfly valves, etc.</p> <p>2. This is for easements that will be required on NTMWD owned land</p> <p>3. This is for ROE and acquisition related costs - NTMWD parcels crossed are not included in this amount</p>								

Table 24 - Conflict Area #4 Alt C Cost Analysis

ORIGINAL ALIGNMENT Type & Description	SEGMENT PARAMETERS			UNIT COSTS		EASEMENT LAND COSTS [\$]	CONSTRUCTION COST	
	Length [ft]	Land Class	Instll. Class	Land [\$/ft]	M&I [\$/ft]		Material & Installation [\$]	& Miscellaneous 1 [\$]
Type 1 - Open	6,611	R	1	53.72	656	355,143	4,336,816	137,769
Type 2 - Wooded	7,765	R	2	53.72	669	417,136	5,194,785	161,817
Type 3 - Creek Crossings	290	R	3	53.72	1094	15,579	317,260	6,043
Type 4 - Road/Parking Lot Crossings	40	R	4	53.72	1047	2,149	41,880	834
Type 5 - Bore or Tunnel Crossings	120	R	5	53.72	1900	6,446	228,000	2,501
Type 6 - Deep Cut (10-15' cover)		R	6	53.72	735	-	-	-
NTMWD Easement Land Cost Reduction ²	1,118	R		53.72		(60,059)	-	-
Parcel Count ³	5	EA		25000	\$/EA	125,000		
Totals:		14,826				\$861,394	\$10,118,741	\$308,963
							CONSTRUCTION COST	\$10,427,704
							CONTINGENCY 20%	\$2,085,541
							TOTAL CONSTRUCTION COST:	\$12,510,000
							TOTAL LAND COST	\$860,000
							TOTAL ROUTE COST	\$13,370,000
<p>1. Appurtenances & Miscellaneous - Includes air valves, blow off valves, butterfly valves, etc.</p> <p>2. This is for easements that will be required on NTMWD owned land</p> <p>3. This is for ROE and acquisition related costs - NTMWD parcels crossed are not included in this amount</p>								



North Texas Municipal Water District

Table 25 - Conflict Area #4 Alt D Cost Analysis

ORIGINAL ALIGNMENT Type & Description	SEGMENT PARAMETERS			UNIT COSTS		EASEMENT LAND COSTS [\$]	CONSTRUCTION COST	
	Length [ft]	Land Class	Instll. Class	Land [\$/ft]	M&I [\$/ft]		Material & Installation [\$]	& Miscellaneous 1 [\$]
Type 1- Open	10,692	R	1	53.72	656	574,374	7,013,952	222,814
Type 2- Wooded	2,293	R	2	53.72	669	123,180	1,534,017	47,784
Type 3 - Creek Crossings	160	R	3	53.72	1094	8,595	175,040	3,334
Type 4 - Road/Parking Lot Crossings	40	R	4	53.72	1047	2,149	41,880	834
Type 5 - Bore or Tunnel Crossings	210	R	5	53.72	1900	11,281	399,000	4,376
Type 6 - Deep Cut (10-15' cover)		R	6	53.72	735	-	-	-
NTMWD Easement Land Cost Reduction ²	1,229	R		53.72		(66,022)	-	-
Parcel Count ³	6	EA		25000	\$/EA	150,000		
Totals:	13,395					\$803,558	\$9,163,889	\$279,142
							CONSTRUCTION COST	\$9,443,031
							CONTINGENCY 20%	\$1,888,606
							TOTAL CONSTRUCTION COST:	\$11,330,000
							TOTAL LAND COST	\$800,000
							TOTAL ROUTE COST	\$12,130,000

1. Appurtenances & Miscellaneous - Includes air valves, blow off valves, butterfly valves, etc.
2. This is for easements that will be required on NTMWD owned land
3. This is for ROE and acquisition related costs - NTMWD parcels crossed are not included in this amount

Table 26 - Conflict Area #5 Alt A Cost Analysis

ORIGINAL ALIGNMENT Type & Description	SEGMENT PARAMETERS			UNIT COSTS		EASEMENT LAND COSTS [\$]	CONSTRUCTION COST	
	Length [ft]	Land Class	Instll. Class	Land [\$/ft]	M&I [\$/ft]		Material & Installation [\$]	& Miscellaneous 1 [\$]
Type 1- Open	8,279	R	1	53.72	656	444,748	5,431,024	172,528
Type 2- Wooded	1,411	R	2	53.72	669	75,799	943,959	29,404
Type 3 - Creek Crossings	508	R	3	53.72	1094	27,290	555,752	10,586
Type 4 - Road/Parking Lot Crossings		R	4	53.72	1047	-	-	-
Type 5 - Bore or Tunnel Crossings		R	5	53.72	1900	-	-	-
Type 6 - Deep Cut (10-15' cover)		R	6	53.72	735	-	-	-
NTMWD Easement Land Cost Reduction ²	7,211	R		53.72		(387,375)	-	-
Parcel Count ³	4	EA		25000	\$/EA	100,000		
Totals:	10,198					\$260,462	\$6,930,735	\$212,519
							CONSTRUCTION COST	\$7,143,254
							CONTINGENCY 20%	\$1,428,651
							TOTAL CONSTRUCTION COST:	\$8,570,000
							TOTAL LAND COST	\$260,000
							TOTAL ROUTE COST	\$8,830,000

1. Appurtenances & Miscellaneous - Includes air valves, blow off valves, butterfly valves, etc.
2. This is for easements that will be required on NTMWD owned land
3. This is for ROE and acquisition related costs - NTMWD parcels crossed are not included in this amount



North Texas Municipal Water District

Table 27 - Conflict Area #5 Alt B Cost Analysis

ORIGINAL ALIGNMENT	SEGMENT PARAMETERS			UNIT COSTS		EASEMENT LAND COSTS	CONSTRUCTION COST		
	Type & Description	Length [ft]	Land Class	Instll. Class	Land [\$/ft]		M&I [\$/ft]	Material & Installation [\$]	& Miscellaneous ¹ [\$]
Type 1 - Open	7,328	R	1	53.72	656	393,660	4,807,168	152,710	
Type 2 - Wooded	3,162	R	2	53.72	669	169,863	2,115,378	65,894	
Type 3 - Creek Crossings	210	R	3	53.72	1094	11,281	229,740	4,376	
Type 4 - Road/Parking Lot Crossings		R	4	53.72	1047	-	-	-	
Type 5 - Bore or Tunnel Crossings		R	5	53.72	1900	-	-	-	
Type 6 - Deep Cut (10-15' cover)		R	6	53.72	735	-	-	-	
NTMWD Easement Land Cost Reduction ²	5,016	R		53.72		(269,460)	-	-	
Parcel Count ³	5	EA		25000	\$/EA	125,000			
Totals:						10,700	\$430,344	\$7,152,286	\$222,980
							CONSTRUCTION COST	\$7,375,266	
							CONTINGENCY 20%	\$1,475,053	
							TOTAL CONSTRUCTION COST:	\$8,850,000	
							TOTAL LAND COST	\$430,000	
							TOTAL ROUTE COST	\$9,280,000	

1. Appurtenances & Miscellaneous - Includes air valves, blow off valves, butterfly valves, etc.
2. This is for easements that will be required on NTMWD owned land
3. This is for ROE and acquisition related costs - NTMWD parcels crossed are not included in this amount

Table 28 - Conflict Area #5 Alt C Cost Analysis

ORIGINAL ALIGNMENT	SEGMENT PARAMETERS			UNIT COSTS		EASEMENT LAND COSTS	CONSTRUCTION COST		
	Type & Description	Length [ft]	Land Class	Instll. Class	Land [\$/ft]		M&I [\$/ft]	Material & Installation [\$]	& Miscellaneous ¹ [\$]
Type 1 - Open	7,327	R	1	53.72	656	393,606	4,806,512	152,689	
Type 2 - Wooded	3,106	R	2	53.72	669	166,854	2,077,914	64,727	
Type 3 - Creek Crossings	240	R	3	53.72	1094	12,893	262,560	5,001	
Type 4 - Road/Parking Lot Crossings		R	4	53.72	1047	-	-	-	
Type 5 - Bore or Tunnel Crossings		R	5	53.72	1900	-	-	-	
Type 6 - Deep Cut (10-15' cover)		R	6	53.72	735	-	-	-	
NTMWD Easement Land Cost Reduction ²	5,448	R		53.72		(292,667)	-	-	
Parcel Count ³	5	EA		25000	\$/EA	125,000			
Totals:						10,673	\$405,687	\$7,146,986	\$222,418
							CONSTRUCTION COST	\$7,369,404	
							CONTINGENCY 20%	\$1,473,881	
							TOTAL CONSTRUCTION COST:	\$8,840,000	
							TOTAL LAND COST	\$410,000	
							TOTAL ROUTE COST	\$9,250,000	

1. Appurtenances & Miscellaneous - Includes air valves, blow off valves, butterfly valves, etc.
2. This is for easements that will be required on NTMWD owned land
3. This is for ROE and acquisition related costs - NTMWD parcels crossed are not included in this amount



North Texas Municipal Water District

Table 29 - Conflict Area #5 Alt D Cost Analysis

ORIGINAL ALIGNMENT Type & Description	SEGMENT PARAMETERS			UNIT COSTS		EASEMENT LAND COSTS [\$]	CONSTRUCTION COST		
	Length [ft]	Land Class	Instll. Class	Land [\$/ft]	M&I [\$/ft]		Material & Installation [\$]	& Miscellaneous 1 [\$]	
Type 1 - Open	8,028	R	1	53.72	656	431,264	5,266,368	167,298	
Type 2 - Wooded	2,293	R	2	53.72	669	123,180	1,534,017	47,784	
Type 3 - Creek Crossings	288	R	3	53.72	1094	15,471	315,072	6,002	
Type 4 - Road/Parking Lot Crossings		R	4	53.72	1047	-	-	-	
Type 5 - Bore or Tunnel Crossings		R	5	53.72	1900	-	-	-	
Type 6 - Deep Cut (10-15' cover)		R	6	53.72	735	-	-	-	
NTMWD Easement Land Cost Reduction ²	6,738	R		53.72		(361,965)	-	-	
Parcel Count ³	6	EA		25000	\$/EA	150,000			
Totals:						10,609	\$357,950	\$7,115,457	\$221,084
							CONSTRUCTION COST	\$7,336,541	
							CONTINGENCY 20%	\$1,467,308	
							TOTAL CONSTRUCTION COST:	\$8,800,000	
							TOTAL LAND COST	\$360,000	
							TOTAL ROUTE COST	\$9,160,000	

1. Appurtenances & Miscellaneous - Includes air valves, blow off valves, butterfly valves, etc.
2. This is for easements that will be required on NTMWD owned land
3. This is for ROE and acquisition related costs - NTMWD parcels crossed are not included in this amount

Table 30 - Conflict Area #6 Alt A Cost Analysis

ORIGINAL ALIGNMENT Type & Description	SEGMENT PARAMETERS			UNIT COSTS		EASEMENT LAND COSTS [\$]	CONSTRUCTION COST		
	Length [ft]	Land Class	Instll. Class	Land [\$/ft]	M&I [\$/ft]		Material & Installation [\$]	& Miscellaneous 1 [\$]	
Type 1 - Open	5,068	R	1	53.72	656	272,253	3,324,608	105,614	
Type 2 - Wooded	791	R	2	53.72	669	42,493	529,179	16,484	
Type 3 - Creek Crossings		R	3	53.72	1094	-	-	-	
Type 4 - Road/Parking Lot Crossings	85	R	4	53.72	1047	4,566	88,995	1,771	
Type 5 - Bore or Tunnel Crossings		R	5	53.72	1900	-	-	-	
Type 6 - Deep Cut (10-15' cover)		R	6	53.72	735	-	-	-	
NTMWD Easement Land Cost Reduction ²		R		53.72		-	-	-	
Parcel Count ³	7	EA		25000	\$/EA	175,000			
Totals:						5,944	\$494,312	\$3,942,782	\$123,869
							CONSTRUCTION COST	\$4,066,651	
							CONTINGENCY 20%	\$813,330	
							TOTAL CONSTRUCTION COST:	\$4,880,000	
							TOTAL LAND COST	\$490,000	
							TOTAL ROUTE COST	\$5,370,000	

1. Appurtenances & Miscellaneous - Includes air valves, blow off valves, butterfly valves, etc.
2. This is for easements that will be required on NTMWD owned land
3. This is for ROE and acquisition related costs - NTMWD parcels crossed are not included in this amount



North Texas Municipal Water District

Table 31 - Conflict Area #6 Alt B Cost Analysis

ORIGINAL ALIGNMENT	SEGMENT PARAMETERS			UNIT COSTS		EASEMENT LAND COSTS	CONSTRUCTION COST		
	Type & Description	Length [ft]	Land Class	Instll. Class	Land [\$/ft]		M&I [\$/ft]	Material & Installation [\$]	& Miscellaneous ¹ [\$]
Type 1 - Open	5,848	R	1	53.72	656	314,155	3,836,288	121,868	
Type 2 - Wooded	223	R	2	53.72	669	11,980	149,187	4,647	
Type 3 - Creek Crossings		R	3	53.72	1094	-	-	-	
Type 4 - Road/Parking Lot Crossings	50	R	4	53.72	1047	2,686	52,350	1,042	
Type 5 - Bore or Tunnel Crossings		R	5	53.72	1900	-	-	-	
Type 6 - Deep Cut (10-15' cover)		R	6	53.72	735	-	-	-	
NTMWD Easement Land Cost Reduction ²		R		53.72		-	-	-	
Parcel Count ³	7	EA		25000	\$/EA	175,000			
Totals:						6,121	\$503,820	\$4,037,825	\$127,557
							CONSTRUCTION COST	\$4,165,382	
							CONTINGENCY 20%	\$833,076	
							TOTAL CONSTRUCTION COST:	\$5,000,000	
							TOTAL LAND COST	\$500,000	
							TOTAL ROUTE COST	\$5,500,000	

1. Appurtenances & Miscellaneous - Includes air valves, blow off valves, butterfly valves, etc.
2. This is for easements that will be required on NTMWD owned land
3. This is for ROE and acquisition related costs - NTMWD parcels crossed are not included in this amount

Table 32 - Conflict Area #6 Alt C Cost Analysis

ORIGINAL ALIGNMENT	SEGMENT PARAMETERS			UNIT COSTS		EASEMENT LAND COSTS	CONSTRUCTION COST		
	Type & Description	Length [ft]	Land Class	Instll. Class	Land [\$/ft]		M&I [\$/ft]	Material & Installation [\$]	& Miscellaneous ¹ [\$]
Type 1 - Open	3,729	R	1	53.72	656	200,322	2,446,224	77,710	
Type 2 - Wooded	2,079	R	2	53.72	669	111,684	1,390,851	43,325	
Type 3 - Creek Crossings	35	R	3	53.72	1094	1,880	38,290	729	
Type 4 - Road/Parking Lot Crossings	30	R	4	53.72	1047	1,612	31,410	625	
Type 5 - Bore or Tunnel Crossings		R	5	53.72	1900	-	-	-	
Type 6 - Deep Cut (10-15' cover)		R	6	53.72	735	-	-	-	
NTMWD Easement Land Cost Reduction ²		R		53.72		-	-	-	
Parcel Count ³	8	EA		25000	\$/EA	200,000			
Totals:						5,873	\$515,498	\$3,906,775	\$122,389
							CONSTRUCTION COST	\$4,029,164	
							CONTINGENCY 20%	\$805,833	
							TOTAL CONSTRUCTION COST:	\$4,830,000	
							TOTAL LAND COST	\$520,000	
							TOTAL ROUTE COST	\$5,350,000	

1. Appurtenances & Miscellaneous - Includes air valves, blow off valves, butterfly valves, etc.
2. This is for easements that will be required on NTMWD owned land
3. This is for ROE and acquisition related costs - NTMWD parcels crossed are not included in this amount



North Texas Municipal Water District

Table 33 - Conflict Area #6 Alt D Cost Analysis

ORIGINAL ALIGNMENT Type & Description	SEGMENT PARAMETERS			UNIT COSTS		EASEMENT LAND COSTS [\$]	CONSTRUCTION COST	
	Length [ft]	Land Class	Instll. Class	Land [\$/ft]	M&I [\$/ft]		Material & Installation [\$]	& Miscellaneous 1 [\$]
Type 1 - Open	3,756	R	1	53.72	656	201,772	2,463,936	78,272
Type 2 - Wooded	2,081	R	2	53.72	669	111,791	1,392,189	43,367
Type 3 - Creek Crossings	35	R	3	53.72	1094	1,880	38,290	729
Type 4 - Road/Parking Lot Crossings	30	R	4	53.72	1047	1,612	31,410	625
Type 5 - Bore or Tunnel Crossings		R	5	53.72	1900	-	-	-
Type 6 - Deep Cut (10-15' cover)		R	6	53.72	735	-	-	-
NTMWD Easement Land Cost Reduction ²	250	R		53.72		(13,430)	-	-
Parcel Count ³	8	EA		25000	\$/EA	200,000		
Totals:		5,902				\$503,625	\$3,925,825	\$122,993
							CONSTRUCTION COST	\$4,048,818
							CONTINGENCY 20%	\$809,764
							TOTAL CONSTRUCTION COST:	\$4,860,000
							TOTAL LAND COST	\$500,000
							TOTAL ROUTE COST	\$5,360,000

1. Appurtenances & Miscellaneous - Includes air valves, blow off valves, butterfly valves, etc.
 2. This is for easements that will be required on NTMWD owned land
 3. This is for ROE and acquisition related costs - NTMWD parcels crossed are not included in this amount

2.2 SECTION A - SOUTH

2.2.1 Introduction

Section A of the LBCR Raw Water Pipeline project was split into two portions as described in **Section 2.1.1**. The dividing point between the southern and northern alignment studies is FM 1743, which is slightly south of US 82. The end point of the southern alignment study is the proposed connection to LBCR Pipeline Section B located at SH 56. The southern portion of Section A is approximately 3.8 miles and is characterized by a general southwesterly bearing.

The analysis described below was used to determine the recommended alignment for the southern portion of the LBCR Pipeline Section A alignment. The alignment selection for the northern portion of Section A has been included in this PDR as **Section 2.1**. The following general parameters were adopted to generate acceptable alignments from the preliminary alignment corridor for analysis: avoid or minimize environmental permitting potential, align beginning with the proposed Section A northern corridor (North of FM 1743), align end with beginning of Section B, minimize pipeline length where it does not impact other parameters, minimize impact to landowners along route, minimize constructability concerns, and avoid significant terrain that negatively affects hydraulics.

North Texas Municipal Water District

2.2.2 Evaluation of Corridors

The preliminary alignment for the southern portion of Section A from FM 1743 to SH 56 is shown in **Figure 11** below as the “Shared Southern Corridor”. This corridor was originally presented in the “Conceptual Facilities Design Route Study Memorandum” dated March 11, 2008. Corridors north of FM 1743 were discussed in the “Section A Corridor Selection Technical Memorandum” dated June 10, 2013.



Figure 11 – Evaluated Corridor

2.2.3 Route Alternatives

The southern Section A corridor was analyzed in further detail to identify conflicts and develop alignment alternatives. Conflicts were determined based upon aerial imagery and field work. Initial conflict development revealed two conflicts. The first conflict area was a string of several houses along CR 2998 and the second conflict area was the Burnett/Bullard creek confluence area. The rest of the terrain in this corridor consists of primarily open and cultivated land with all possible alignment

North Texas Municipal Water District

alternatives sharing three creek crossings. The alignments shown have had an initial field environmental study performed and there are no anticipated wetland concerns. Alternate B was set outside of the original corridor and therefore direct field investigations within portions of this alignment were not executed. However, the areas investigated within the corridor near Alternate B and desktop reviews did not provide evidence of environmental impact; therefore, no environmental impacts would be expected along alternate B.

From this analysis, four alignment alternatives were developed to navigate the conflict areas. Due to the size and close proximity between the two conflict areas, merging the alignment alternatives between them was not a beneficial option. The alignment alternatives were evaluated based on the parameters listed in the introduction and are shown in

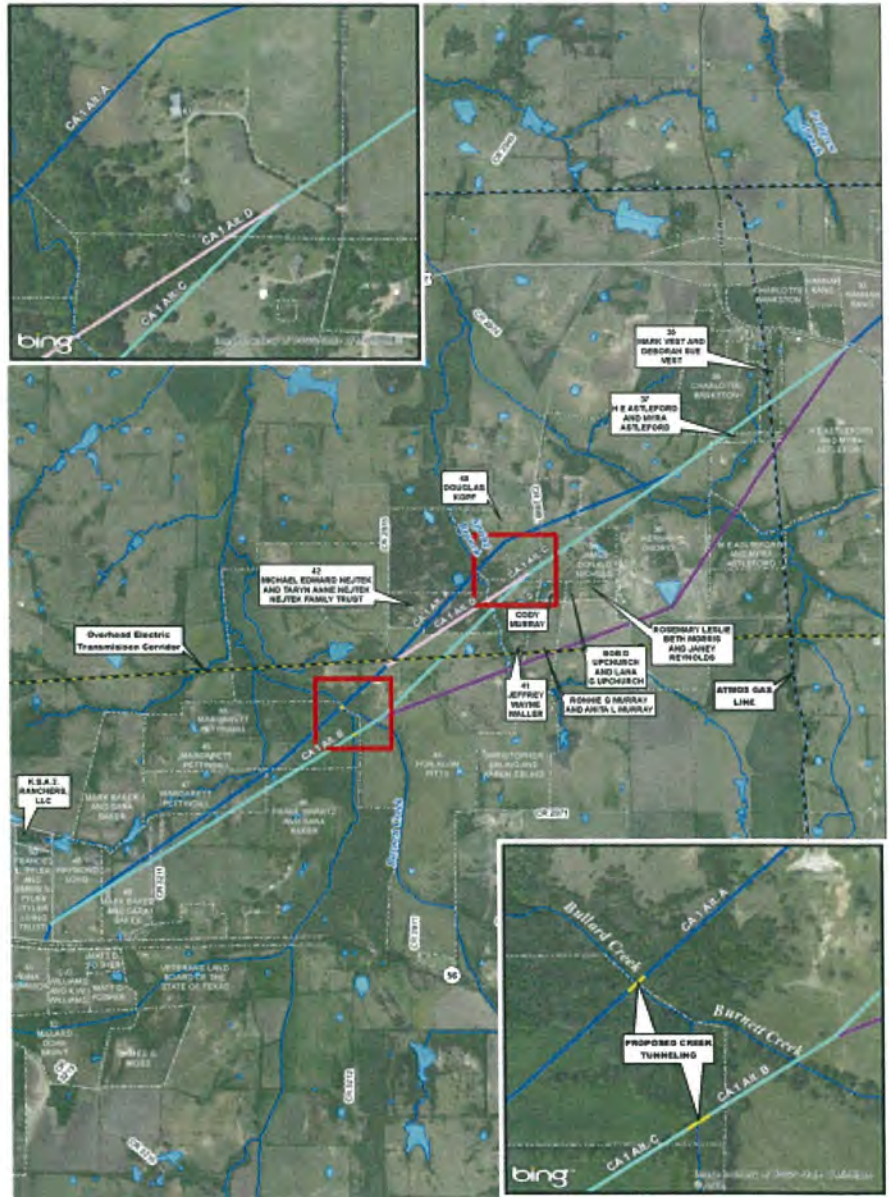

Figure 12.

Figure 12 – Overall Segment A – South Alignments

The preferred alternative was determined by analysis that compared the total length, number of parcels affected, open cut length, wooded length, tunnel length, construction cost, and land acquisition cost. The recommended alignment was chosen based on the completed cost analysis and engineering

North Texas Municipal Water District

judgment. The detailed route analysis of these four alignment alternatives is discussed below.

Conflict Area #1 was identified because of the close proximity of the string of houses along CR 2998 to each other. The seven homesteads run mainly east-west across the general southwest direction of the alignment alternatives. Four alignments have been proposed to provide a compromise between landowner impact, constructability, and cost. Three alternatives were developed to cross through this conflict area. Two alternatives diverged either north or south of the conflict area, adding additional length while minimizing the impact to the land owners. The third option aligned between two homesteads as a more direct route. Conflict Area #1 and the three alternatives can be seen in **Figure 13**.



Figure 13 – Aerial View of Conflict Area #1

Conflict Area #2 is the Bullard/Burnett Creek confluence. **Figure 14** on the next page shows a close up view of the conflict area and the possible alignments through the area. Due to environmental and constructability concerns, proceeding directly through the creek confluence was not considered within the alignment options. Two alternatives were developed for proceeding through this conflict area. One option would be to cross Bullard Creek northwest and downstream of the confluence. This option

North Texas Municipal Water District

would result in a larger creek and riparian area crossing, but only crosses the creek once. A second option would be to cross Bullard and Burnett Creeks separately southeast and upstream of their confluence. This option would yield much smaller creek and riparian area crossings; however, two creek crossings would be required which may cause access issues for maintenance and operation of the pipeline. The crossing associated with Bullard Creek would be installed by bore or tunnel due to its deep channel and steep banks. The pipeline crossing at Burnett Creek would be installed by open cut because its creek channel is shallower with more gently sloped banks.

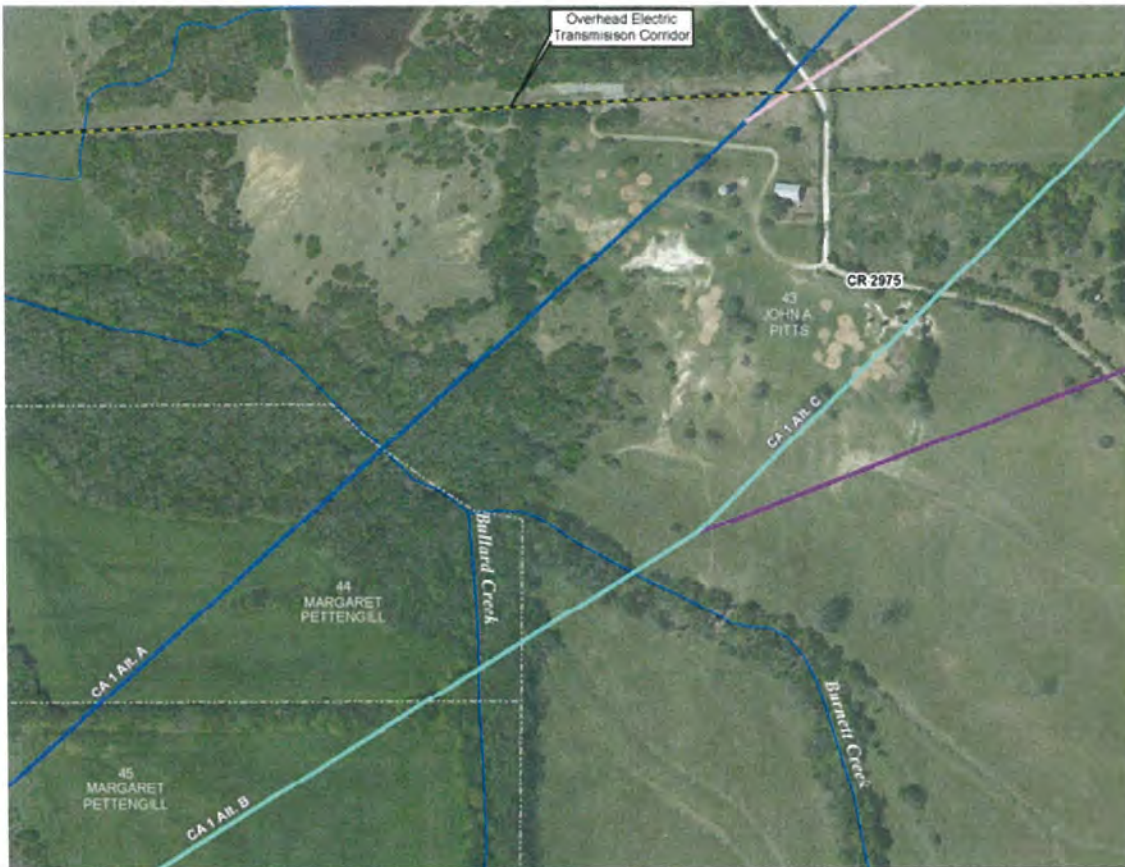

Figure 14 – Aerial View of Conflict Area #2

2.2.4 Detailed Route Analysis

Installation cost factors were developed to take into account the varying costs of pipeline construction through different land classifications. Cost data was updated in order to closely coincide with recent bid information. Routes were classified by the type of land they would be installed in: open, wooded, open

North Texas Municipal Water District

cut creek crossings, open cut road crossings, or tunneled crossings. A construction and land acquisition cost was associated with each classification in order to estimate the total route cost per linear foot. This allowed a cost to be generated for each alternate based upon the linear feet of the land classification. From this, a cost comparison was performed for the alternates in order to determine the most cost effective route.

Alternate A begins at the common starting point along FM 1743. From there, the alignment proceeds southwest crossing a small seasonal tributary of Cottonwood Creek and its associated riparian area. The alignment continues into a field where a slight northern deviation occurs before crossing Cottonwood Creek. Alternate A then crosses CR 2998 before nearing the northern edge of the previously mentioned Conflict Area #1. The alignment centerline at its closest point is 150 feet away from a non-residential structure and 450 feet away from the property's residential structure further to the south. While near the property's non-residential structure, the alignment makes an approximate 30 degree bend to the south where it proceeds to cross Spring Branch and its riparian area. After crossing the branch, the alignment nears a half acre pond before crossing an overhead electrical distribution line and CR 2975. The alignment then declines down a hill towards Conflict Area #2, the Bullard and Burnett Creek Confluence. Alternate A crosses Bullard Creek downstream and to the north of the confluence before traveling between a small pond and a seasonal tributary for Bullard Creek. The alignment then crosses CR 3211 while continuing in a southwest bearing. The alignment ends by taking a 60 degree southern turn just after traveling past a residential and non-residential structure. The alternate has approximately 270 feet and 200 feet of clearance between the residential and non-residential structures, respectively. Shortly after turning south, the alignment reaches SH 56 and the beginning of Section B.

Alternate B begins at the common starting point along FM 1743. From there, the alignment proceeds southwest crossing Cottonwood Creek and its riparian areas. The alignment proceeds southwest around a large pond before turning approximately 45 degrees to the west and crossing the intersection of CRs 2998 and 2970. Alternate B then nears the southern edge of the previously mentioned Conflict Area #1. The alignment centerline at its closest point is 165 feet away from a non-residential structure and 330 feet away from the property's residential structure further to the northwest. The alignment proceeds southwest through open pasture land before crossing an overhead electric distribution line and Spring

North Texas Municipal Water District

Branch and its riparian area. Alternate B then crosses CR 2975 before approaching Conflict Area #2. Alternate B crosses the creek confluence upstream and to the southeast to cross the two creeks individually. The alignment crosses the shallower and narrower Burnett Creek before crossing the larger Bullard Creek to the southwest. Alternate B then passes through primarily open land before crossing CR 3211. Alternate B then merges with Alternate A and turns south toward SH 56 and the beginning of Section B. It should be noted that part of Alternate B is outside of the proposed corridor set in the "Conceptual Facilities Design Route Study Memo" dated March 11, 2008. Therefore, there are four parcels that the alignment crosses that were not included in the original ROE mailing list. Also, the desktop review and initial environmental study conducted was in the general area of Alternate B and did not yield any areas of environmental concern.

Alternate C begins merged with Alternate A until just before the Cottonwood Creek crossing. At this point, Alignment C continues on from the previous bearing and crosses CR 2998 and enters the previously mentioned Conflict Area #1. Alignment C proceeds between two of the homesteads as to keep a more direct route to the beginning of Section B. The alignment splits these houses with approximately 200 feet from centerline to either residential structure. Alternate C then crosses Spring Branch along with its associated riparian area before continuing through open pasture land to cross an overhead electric distribution line and CR 2975. After crossing CR 2975, the alignment merges with the previously stated Alternate B before crossing Burnett and Bullard Creeks separately upstream and to the southeast of the creek confluence. The alignment continues along the same route as Alternate B to SH 56 and the beginning of Section B.

Alternate D begins merged with Alternate A until just before the Cottonwood Creek crossing. At this point, the alignment continues with Alternate C until splitting the two residential structures to the southwest. At this point, the alignment proceeds in a more continuous bearing and is approximately 165 feet from the northern structure and 215 feet from the southern structure at their closest points. Alternate D then crosses through approximately 650 feet of wooded area before crossing Spring Branch. The alignment then continues south and connects to Alternate A after crossing an overhead electric distribution line and CR 2975. This alignment crosses Bullard Creek downstream and to the northwest of the Bullard/Burnett Creek Confluence and continues along Alternate A to SH 56 and the beginning of Section B.

North Texas Municipal Water District

In order to properly analyze the various alternatives developed for the conflict areas, data was collected and is summarized in **Table 34**. The weighted route scores analysis was utilized in determining the preferred route across the southern portion of Section A. **Table 35** shows a breakdown of these scores. This analysis utilized various factors such as length, parcel crossings, environmental crossings and transportation right-of-way crossings. These factors were weighted in relevance to their general impact throughout the project. For example, route length is the highest weighted factor due to its general correlation with cost, landowner easement acquisition quantity, and construction time. Through the summation and analysis of the weighted factors a preferred alignment can be chosen.

Preliminary cost estimating spreadsheets were utilized in determining the associated costs of the four evaluated alignments. These cost estimating spreadsheets incorporate bid data from recent pipeline projects to develop the costs for the type of pipe, pipe installation, relevant appurtenances, and easement acquisition costs. The cost analysis for the conflict areas is shown below in **Table 34**.

Table 34 – Analysis for Section A Conflict Areas

Option	Alternate A	Alternate B	Alternate C	Alternate D
Length (ft.)	20,040	20,438	19,919	19,863
Number of Parcels	18	17	17	19
Open Length (ft.)	14,122	16,858	14,429	13,893
Wooded Length (ft.)	5,768	3,480	5,390	5,820
Tunnel/Bore Length	150	100	100	150
Construction Cost	\$16,800,000	\$17,060,000	\$16,650,000	\$16,670,000
Land Acquisition Cost	\$1,530,000	\$1,520,000	\$1,500,000	\$1,540,000
Total Cost	\$18,330,000	\$18,580,000	\$18,150,000	\$18,210,000

*For further cost analysis data see **Tables 38-41**.

The pipeline route evaluation criteria spreadsheet that was mentioned previously to analyze the characteristics of the alignments from FM 1743 to SH 56 can be seen on the next page in **Table 35**. FNI filled in the weights based on our engineering judgment and input from the NTMWD.

Table 35 – Weighted Route Scores

Raw Quantities (Low is Best)					
Item Description	Item Weight (High = Most Important) (0 = Not Considered)	Routes			
		Proposed A	Proposed B	Proposed C	Proposed D
Route Length, ft	40	20,040	20,438	19,919	19,863
Parcel Count, ea	15	18	17	17	19
Wooded Crossing, ft	10	5,358	2,965	4,905	5,370
Perennial Stream Crossing, ea	10	-	-	-	-
Intermittent Stream Crossing, ea	9	4	4	5	4
Hydric Soil Crossing, ft	9	-	-	-	-
Bored Crossing (TXDOT & RR), ea	7	1	1	1	1
Total	100				
Normalized Score (Low is Best)					
Item Description	Item Weight	Proposed A	Proposed B	Proposed C	Proposed D
Route Length, ft	40.00	34.85	35.54	34.64	34.54
Parcel Count, ea	15.00	9.00	8.50	8.50	9.50
Wooded Crossing, ft	10.00	2.23	1.23	2.04	2.23
Perennial Stream Crossing, ea	10.00	1.00	1.00	1.00	1.00
Intermittent Stream Crossing, ea	9.00	4.00	4.00	5.00	4.00
Hydric Soil Crossing, ft	9.00	1.00	1.00	1.00	1.00
Bored Crossing (TXDOT & RR), ea	7.00	1.00	1.00	1.00	1.00
Total	100.00	53.08	52.28	53.18	53.28
Weighted Score (Low is Best)					
Item Description	Item Weight	Proposed A	Proposed B	Proposed C	Proposed D
Route Length, ft	40.00	13.94	14.22	13.86	13.82
Parcel Count, ea	15.00	1.35	1.28	1.28	1.43
Wooded Crossing, ft	10.00	0.22	0.12	0.20	0.22
Perennial Stream Crossing, ea	10.00	0.10	0.10	0.10	0.10
Intermittent Stream Crossing, ea	9.00	0.36	0.36	0.45	0.36
Hydric Soil Crossing, ft	9.00	0.09	0.09	0.09	0.09
Bored Crossing (TXDOT & RR), ea	7.00	0.07	0.07	0.07	0.07
Total	100.00	16.13	16.24	16.05	16.09

North Texas Municipal Water District

Based on the analysis, Alternate C was selected as the recommended alignment due to a number of factors such as: length, parcel count, wooded areas, stream crossings, and number of bored locations (**Table 35**). From the analysis, it can be seen that the scores presented a small variance; however, Alternate C presented the best score in regards to the Section A alignment analysis and therefore is the recommended route.

A summary of costs for Alternates A-D is shown in **Table 34**. This summary of costs does not take into account the pipe length between FM 1743 and US 82. The OPCC for the northern portion of Section A has been included in this PDR as **Section 2.1.5**.

2.2.5 Opinion of Probable Construction Cost

The OPCC for the Section A southern recommended alignment (Alternative C) is \$20,902,450. A detailed breakdown of the OPCC for Alternate C is shown in **Table 36**.



North Texas Municipal Water District

Table 36 – Opinion of Probable Construction Costs

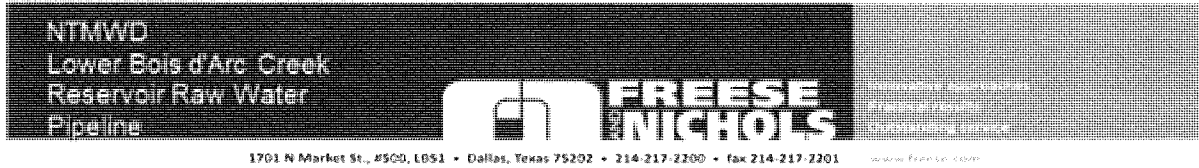

OPINION OF PROBABLE CONSTRUCTION COSTS (INCLUDING EASEMENTS) November 25, 2013

ESTIMATOR WRS	CHECKED BY ASM	ACCOUNT NO NTD13136
-------------------------	--------------------------	-------------------------------

ITEM	DESCRIPTION	QUANTITY	UNIT	UNIT PRICE	TOTAL
1	90-INCH PIPELINE	19,919	LF	\$650.00	\$ 12,947,350
2	TUNNELLED CROSSINGS	0	LF	\$1,970.00	\$ -
3	PIPELINE ROW CLEARING	50	AC	\$5,000.00	\$ 250,000
4	TRENCH SAFETY	19,919	LF	\$1.00	\$ 19,919
5	AIR RELEASE VALVES	6	EA	\$25,000.00	\$ 142,500
6	BUTTERFLY VALVES	1	EA	\$165,000.00	\$ 165,000
7	BLOW OFF VALVES	6	EA	\$25,000.00	\$ 142,500
8	PAVEMENT RESTORATION	440	SY	\$70.00	\$ 30,800
9	CREEK CROSSINGS	455	LF	\$445.00	\$ 202,475
10	REVEGETATION	50	AC	\$1,160.00	\$ 58,000
11	FIBER OPTIC CONDUIT	19,919	LF	\$3.00	\$ 59,757
12	FIBER	19,919	LF	\$2.00	\$ 39,838
13	CATHODIC PROTECTION	19,919	LF	\$2.00	\$ 39,838
14	ACCESS MANNWAYS	6	EA	\$10,000.00	\$ 57,000
15	TESTING	19,919	LF	\$2.00	\$ 39,838
16	MOBILIZATION	1	LS	\$709,741.00	\$ 709,741

CONSTRUCTION SUBTOTAL		\$ 14,965,000
CONSTRUCTION CONTINGENCY	17%	\$ 2,235,000
CONSTRUCTION TOTAL		\$ 17,135,000

ESTIMATED EASEMENT/PROPERTY COSTS		
PERMANENT EASEMENT W/ ASSOCIATED TEMPORARY (Note 3)	995,950 SF	\$1.00 \$995,950.00
TOTAL ESTIMATED COSTS (INCLUDING EASEMENT)		\$18,130,950.00

1. Estimated Easement Costs Based on a 50' Perm Easement & 70' Temp Easement for the Entire Route

2.2.6 Recommendations Summary

The proposed Alternate C is the recommended alignment selection for this specific corridor between FM 1743 and SH 56. Alternate C is the shortest route through the Conflict Area #1 and therefore will reduce cost and length of pipe while still providing a reasonable distance from the nearby structures. The southeast crossing of Conflict Area #2 by Alternate C also provides an additional benefit over the other route at this crossing. Alternate C's creek crossings in this area are narrower and shallower and provide significantly less wooded area to cross than the other alternates. It is because of these advantages and the numerical analysis shown in **Table 35** that FNI recommends Alternate C for the alignment of the

North Texas Municipal Water District

southern portion of Section A.

2.2.7 Pipeline Crossings

Table 37 below presents identified utility, roadway, and creek crossings associated with the recommended route.

Table 37 – Major Transportation, Utility, and Waterbody Crossings

Road
Fannin CR 2998
Fannin CR 2970
Fannin CR 2975
Fannin CR 3211
Utility
Atmos 3.5" Gas Distribution Line
Oncor Overhead Electric Distribution Lines
Waterbody
Cottonwood Creek
Spring Branch
Bullard Creek
Burnett Creek



North Texas Municipal Water District

Table 38 - Conflict Area #1 Alt A Cost Analysis

ORIGINAL ALIGNMENT	SEGMENT PARAMETERS			UNIT COSTS		EASEMENT LAND COSTS	CONSTRUCTION COST		
	Type & Description	Length (ft)	Land Class	Instll. Class	Land (\$/ft)		M&I (\$/ft)	Material & Installation (\$)	& Miscellaneous ¹ (\$)
Type 1- Open	14,122	R	1	53.72	656	758,634	9,264,032	294,292	
Type 2- Wooded	5,358	R	2	53.72	669	287,832	3,584,502	111,657	
Type 3 - Creek Crossings	350	R	3	53.72	1094	18,802	382,900	7,294	
Type 4 - Road/Parking Lot Crossings	60	R	4	53.72	1047	3,223	62,820	1,250	
Type 5 - Bore or Tunnel Crossings	150	R	5	53.72	1900	8,058	285,000	3,126	
Type 6 - Deep Cut (10-15' cover)		R	6	53.72	735	-	-	-	
Parcel Count ²	18	EA		25000	\$/EA	450,000			
Totals:						20,040	\$1,526,549	\$13,579,254	\$417,619
							CONSTRUCTION COST	\$13,996,873	
							CONTINGENCY 20%	\$2,799,375	
1. Appurtenances & Miscellaneous - Includes air valves, blow off valves, butterfly valves, etc.							TOTAL CONSTRUCTION COST:	\$16,800,000	
2. This is for ROE and acquisition related costs							TOTAL LAND COST	\$1,530,000	
							TOTAL ROUTE COST	\$18,330,000	

Table 39 - Conflict Area #1 Alt B Cost Analysis

ORIGINAL ALIGNMENT	SEGMENT PARAMETERS			UNIT COSTS		EASEMENT LAND COSTS	CONSTRUCTION COST		
	Type & Description	Length (ft)	Land Class	Instll. Class	Land (\$/ft)		M&I (\$/ft)	Material & Installation (\$)	& Miscellaneous ¹ (\$)
Type 1- Open	16,858	R	1	53.72	656	905,612	11,058,848	351,309	
Type 2- Wooded	2,965	R	2	53.72	669	159,280	1,983,585	61,788	
Type 3 - Creek Crossings	455	R	3	53.72	1094	24,443	497,770	9,482	
Type 4 - Road/Parking Lot Crossings	60	R	4	53.72	1047	3,223	62,820	1,250	
Type 5 - Bore or Tunnel Crossings	100	R	5	53.72	1900	5,372	190,000	2,084	
Type 6 - Deep Cut (10-15' cover)		R	6	53.72	735	-	-	-	
Parcel Count ²	17	EA		25000	\$/EA	425,000			
Totals:						20,438	\$1,522,929	\$13,793,023	\$425,913
							CONSTRUCTION COST	\$14,218,936	
							CONTINGENCY 20%	\$2,843,787	
1. Appurtenances & Miscellaneous - Includes air valves, blow off valves, butterfly valves, etc.							TOTAL CONSTRUCTION COST:	\$17,060,000	
2. This is for ROE and acquisition related costs							TOTAL LAND COST	\$1,520,000	
							TOTAL ROUTE COST	\$18,580,000	



North Texas Municipal Water District

Table 40 - Conflict Area #1 Alt C Cost Analysis

ORIGINAL ALIGNMENT Type & Description	SEGMENT PARAMETERS			UNIT COSTS		EASEMENT LAND COSTS [\$]	CONSTRUCTION COST		
	Length [ft]	Land Class	Instll. Class	Land [\$/ft]	M&I [\$/ft]		Material & Installation [\$]	& Miscellaneous 1 [\$]	
Type 1 - Open	14,429	R	1	53.72	656	775,126	9,465,424	300,690	
Type 2 - Wooded	4,905	R	2	53.72	669	263,497	3,281,445	102,217	
Type 3 - Creek Crossings	405	R	3	53.72	1094	21,757	443,070	8,440	
Type 4 - Road/Parking Lot Crossings	80	R	4	53.72	1047	4,298	83,760	1,667	
Type 5 - Bore or Tunnel Crossings	100	R	5	53.72	1900	5,372	190,000	2,084	
Type 6 - Deep Cut (10-15' cover)		R	6	53.72	735	-	-	-	
Parcel Count ²	17	EA		25000	\$/EA	425,000			
Totals:						19,919	\$1,495,049	\$13,463,699	\$415,098
							CONSTRUCTION COST	\$13,878,797	
							CONTINGENCY 20%	\$2,775,759	
							TOTAL CONSTRUCTION COST:	\$16,650,000	
							TOTAL LAND COST	\$1,500,000	
							TOTAL ROUTE COST	\$18,150,000	

1. Appurtenances & Miscellaneous - Includes air valves, blow off valves, butterfly valves, etc.
2. This is for ROE and acquisition related costs

Table 41 - Conflict Area #1 Alt D Cost Analysis

ORIGINAL ALIGNMENT Type & Description	SEGMENT PARAMETERS			UNIT COSTS		EASEMENT LAND COSTS [\$]	CONSTRUCTION COST		
	Length [ft]	Land Class	Instll. Class	Land [\$/ft]	M&I [\$/ft]		Material & Installation [\$]	& Miscellaneous 1 [\$]	
Type 1 - Open	13,893	R	1	53.72	656	746,332	9,113,808	289,520	
Type 2 - Wooded	5,370	R	2	53.72	669	288,476	3,592,530	111,907	
Type 3 - Creek Crossings	350	R	3	53.72	1094	18,802	382,900	7,294	
Type 4 - Road/Parking Lot Crossings	100	R	4	53.72	1047	5,372	104,700	2,084	
Type 5 - Bore or Tunnel Crossings	150	R	5	53.72	1900	8,058	285,000	3,126	
Type 6 - Deep Cut (10-15' cover)		R	6	53.72	735	-	-	-	
Parcel Count ²	19	EA		25000	\$/EA	475,000			
Totals:						19,863	\$1,542,040	\$13,478,938	\$413,931
							CONSTRUCTION COST	\$13,892,869	
							CONTINGENCY 20%	\$2,778,574	
							TOTAL CONSTRUCTION COST:	\$16,670,000	
							TOTAL LAND COST	\$1,540,000	
							TOTAL ROUTE COST	\$18,210,000	

1. Appurtenances & Miscellaneous - Includes air valves, blow off valves, butterfly valves, etc.
2. This is for ROE and acquisition related costs

North Texas Municipal Water District

2.3 SECTION B

2.3.1 Introduction

Section B of the LBCR Raw Water Pipeline connects with Section A approximately 1 mile east of Dodd City at the north right of way line of SH 56. The route crosses the highway and the adjacent Texas Northeastern Railroad (TNER) track and generally routed to the southwest for approximately 9.89 miles terminating at Section C on the southwest corner of FM 68 and FM 3115.

The original preliminary pipeline corridor was determined in “NTMWD Preliminary Pipeline Routing Study and Conceptual Pump Station Design Report” by completing a high level analysis of pipeline corridors from the proposed LBCR pump station to the proposed NWTP site. The pump station was relocated as a portion of this project, but this did not change the pipeline corridor for Section B. The preliminary alignment corridor was reviewed for modifications to shorten the route but minimize additional tree loss and not intrude on forested wetlands, while minimizing overall construction costs. Since this area has typical large tracts paralleling property lines was not a high priority in the analysis. Various options were examined at identified conflict areas and additional analysis was completed to take into account costs associated with easements, road crossings, and construction. The analysis discussed in this PDR details the process of determining the final pipeline alignment from the preliminary corridor and various alternatives developed during this phase of the pipeline route selection.

2.3.2 Route Alternatives

The preliminary pipeline alignment corridor was investigated further in order to identify potential conflict areas along the route. Conflicts were determined based upon aerial imagery and field work walking the potential pipeline routes. A detailed evaluation of localized alternatives was performed to optimize the pipeline alignment and avoid potential conflicts in land acquisition and construction. Environmental constraints such as stream crossings, perennial water bodies, and possible wetlands along with impacts to property owners were taken into account during the analysis.

The original alignment corridor centerline is shown in blue and in each conflict area and described as Alternate A in this memorandum. On all figures, Conflict Area Alternate B's are magenta, Alternate C's are teal and Alternate D's are pink.

North Texas Municipal Water District

Six conflict areas were identified on the potential pipeline route of Section B. Conflict Area #1 begins in the first parcel south of SH 56 and the TNER tracks and comes back to the original alignment at CR 3200. The Conflict Area #2 is located between CR 3205 and FM 2077. The alternates for this conflict area either parallel property lines or cut across country. Conflict Area #3 is between FM 2077 and FM 1550 and again the alternates either parallel property lines or cut across country. The Conflict Area #4 is between FM1550 and CR 3302 and again an alternate was developed to cut across country instead of following property lines. Conflict Area #5 is from the end of Conflict Area #4 at CR 3302 to CR 3120. Alternates involve routing to reducing pipeline length, along with one stream crossing or reducing the number of property owners impacted by the construction. Conflict Area #6 is between CR 3120 and FM 3115. The alternate parallels a 36 inch natural gas line rather than paralleling a property line. The overall route is shown in **Figure 15**.

The preferred alternatives were determined by analysis that compared the total length, number of parcels crossed, open cut length, wooded length, tunnel length, construction cost, and land acquisition cost. The recommended alignment was chosen based on the cost analysis and engineering judgment of the above mentioned impacts. The detailed route analysis of these six conflict areas is discussed below.

2.3.3 Detailed Route Analysis

In order to properly analyze the various alternatives developed for the conflict areas, data was collected and input into a pipeline route evaluation criteria

spreadsheet. Cost data was updated to estimate future pipeline construction costs based on recent bid information. Routes were classified by the type of land the pipeline would be installed in: open area,

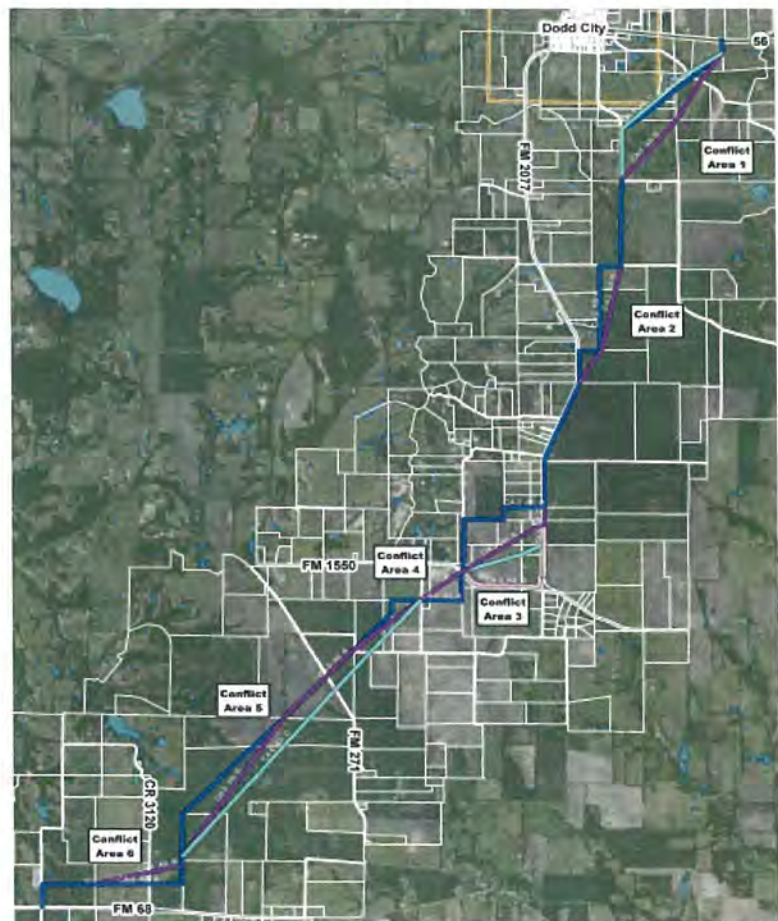

Figure 15 – Overall Segment B Alignment

North Texas Municipal Water District

wooded, open cut creek crossings, open cut road crossings, or tunneled crossings. A construction cost and land acquisition cost was associated with each classification in order to estimate the total route cost per linear foot. This allowed a cost to be generated for each alternate based upon the linear feet of the land classification. A cost comparison was performed for the alternates of each conflict area to determine the most cost effective route. The route with the lowest cost was generally selected as the preferred route; however, engineering judgment was also used to ensure that potential complications were also evaluated.

Conflict Area #1 was identified because of the potential to reduce the number of properties affected and shorten the route while maintaining creek crossing construction viability as seen in **Figure 16**. Three alternatives were analyzed for this conflict area.

Alternate A was the original preliminary alignment corridor. Alternate B was developed to minimize the number of parcels crossed, along with providing the

shortest pipeline route. Alternate C was developed to minimize the pipeline wooded length and provide a more favorable creek crossing scenario. The creek crossings for each alternate can be done by open cut method with bank restoration in compliance with Nationwide Permit 12 crossing parameters. Analysis of Conflict Area #1 is shown in **Table 42**.



Figure 16 – Aerial View of Conflict Area #1

Table 42 – Analysis for Conflict Area #1

Option	Alternate A	Alternate B	Alternate C
Length	7622	7034	7626
Number of Parcels	5	4	6
Open Length (ft.)	6577	5487	6825
Wooded Length (ft.)	1045	1547	697
Tunnel/Bore Length	0	0	0
Construction Cost	\$6,260,000	\$5,850,000	\$6,260,000
Land Acquisition Cost	\$530,000	\$480,000	\$560,000
Total Cost	\$6,790,000	\$6,330,000	\$6,820,000

*For further cost analysis data see **Tables 50-52**.

From the analysis performed, Alternate A and C are very similar in construction cost, but Alternate B is recommended. Alternate B is considerably cheaper due to the reduced length and parcel crossings. In addition, the main property owner, Millard Brent owns three of the four parcels in Alternate B.

Conflict Area #2 was identified because of the potential to reduce the overall length, avoid a small pond, and potential forested wetland area in the vicinity of the property corner between two of the properties. The two alternatives analyzed for this conflict area can be seen in **Figure 17**.

Alternate A routed the pipeline parallel to the south side of CR 3205 before crossing south and following property lines. Alternate B crossed CR 3205 and routed the pipe across an open field, bisecting three properties. Analysis of Conflict Area #2 is shown in **Table 43**.



Figure 17 – Aerial View of Conflict Area #2

North Texas Municipal Water District

Table 43 – Analysis for Conflict Area #2

Option	Alternate A	Alternate B
Length	6965	5578
Number of Parcels	3	3
Open Length (ft.)	5806	5500
Wooded Length (ft.)	1082	78
Tunnel/Bore Length	77	0
Construction Cost	\$5,810,000	\$4,530,000
Land Acquisition Cost	\$450,000	\$370,000
Total Cost	\$6,260,000	\$4,900,000

*For further cost analysis data see **Tables 53 & 54**.

Alternate B is the recommended route due to the fact it is the shorter alternate, considerably cheaper, and eliminates potential issues with the pond and wetland area. Both alternate alignments cross the same number of parcels. Alternate B bisects properties but avoids the pond and wetland area by approximately 75 feet, while Alternate A crosses very close to the pond and through the wetland area.

Conflict Area #3 was evaluated in order to shorten the pipeline alignment and reduce the number of bends required. Four alternatives were analyzed for this conflict area and can be seen in **Figure 18**. Alternate A proposed to align the pipe parallel to property lines and traveled due west or due south through the conflict area. Alternates B and C route through open land, bisecting several properties in order to reduce the pipeline length. Alternate D follows the right of



Figure 18 – Aerial View of Conflict Area #3

North Texas Municipal Water District

way of FM 2077 and FM 1550. Alternates B, C, and D all cross creeks at select locations, but the proposed crossings can be accomplished with open cut methods and bank restoration in compliance with Nationwide Permit 12 requirements. Analysis of Conflict Area #3 is shown in **Table 44**.

Table 44 – Analysis for Conflict Area #3

Option	Alternate A	Alternate B	Alternate C	Alternate D
Length	6170	4757	5266	7084
Number of Parcels	5	6	6	5
Open Length (ft.)	5763	4458	5054	6890
Wooded Length (ft.)	297	195	112	58
Tunnel/Bore Length	110	105	100	100
Construction Cost	\$5,180,000	\$4,030,000	\$4,430,000	\$5,920,000
Land Acquisition Cost	\$460,000	\$410,000	\$430,000	\$510,000
Total Cost	\$5,660,000	\$4,440,000	\$4,840,000	\$6,430,000

*For further cost analysis data see **Tables 55-58**.

Alternate B is the recommended route because it is the shortest option and the least expensive of the alternatives. Alternate A, C, and D are all longer and therefore have a greater construction cost and land acquisition cost than Alternate B. In addition, Alternate C and D pass an old barn structure that has been preliminarily flagged as a potential historical structure. These routes should still miss the structure, but will require further historical investigation. Alternate B veers westward cross country prior to this structure, therefore avoiding any further investigation of the structure.

Conflict Area #4 was identified due to potential savings for cutting cross country rather than paralleling property lines between FM 1550 and CR 3302. Two alternates were analyzed for this conflict area shown in **Figure 19**.

Alternate A paralleled property lines to head south after crossing FM 1550. Alternate B routed cross country between FM 1550 and CR 3302. Analysis of Conflict Area #4 is shown in **Table 45**.



Figure 19 – Aerial View of Conflict Area #4

Table 45 – Analysis for Conflict Area #4

Option	Alternate A	Alternate B
Length	3023	2155
Number of Parcels	2	2
Open Length (ft.)	2862	2016
Wooded Length (ft.)	53	39
Tunnel/Bore Length	108	101
Construction Cost	\$2,620,000	\$1,910,000
Land Acquisition Cost	\$210,000	\$170,000
Total Cost	\$2,830,000	\$2,080,000

*For further cost analysis data see **Tables 59 & 60.**

Alternate B was selected as the recommended route since it is significantly shorter and less expensive than Alternate A.

Conflict Area #5 was identified due to potential savings for cutting cross country with slightly different alignments at the end of Conflict Area #4, between CR 3302 and CR 3120. Three alternatives were considered for this conflict area shown below in **Figure 20**.

The original preliminary alignment, Alternate A, paralleled property lines at the north and south ends of the conflict area, but routed through open land for most of the conflict area. Alternate B and C routed cross country between CR 3302 and CR 3120. Analysis of Conflict Area #5 is shown in **Table 46**.



Table 46 – Analysis for Conflict Area #5

Option	Alternate A	Alternate B	Alternate C
Length	16062	15169	15054
Number of Parcels	7	8	9
Open Length (ft.)	15883	14999	14724
Wooded Length (ft.)	104	96	98
Tunnel/Bore Length	50	52	54
Construction Cost	\$13,130,000	\$12,410,000	\$12,400,000
Land Acquisition Cost	\$1,010,000	\$1,010,100	\$1,030,000
Total Cost	\$14,140,000	\$13,420,000	\$13,430,000

*For further cost analysis data see **Tables 61-63**.

Alternate C is the recommended route because it is the shortest route and the least expensive. Alternate A crosses the least number of parcels, but is approximately 1,000 feet longer than Alternate C and the most costly. Alternate C has two creek crossings, but they do not have wetlands associated with them and can be accomplished with open cut methods and bank restoration in compliance with Nationwide Permit 12 requirements.

Conflict Area #6 was identified due to potential savings for cutting cross country rather than paralleling property lines between CR 3120 and CR 3116. Two alternates were analyzed for this conflict area shown in **Figure 21**.

Alternate A was the preliminary alignment and paralleled property lines. Alternate B routed cross country aligning with an existing cross country 36 inch natural gas line. Analysis of Conflict Area #6 is shown in **Table 47**.



Figure 21 – Aerial View of Conflict Area #6

Table 47 – Analysis for Conflict Area #6

Option	Alternate A	Alternate B
Length	4357	3655
Number of Parcels	1	1
Open Length (ft.)	4255	3594
Wooded Length (ft.)	85	42
Tunnel/Bore Length	0	0
Construction Cost	\$3,550,000	\$2,980,000
Land Acquisition Cost	\$260,000	\$220,000
Total Cost	\$3,810,000	\$3,200,000

*For further cost analysis data see **Tables 64 & 65**.

Alternate B is recommended because of the reduced length and cost savings associated with it. Even though the Alternate B bisects properties, the alignment would be following an existing pipeline. Also, Alternate A crosses the gas pipeline twice, which would result in a greater construction cost.

2.3.4 Opinion of Probable Construction Cost

The Opinion of Probable Construction Cost (OPCC) for the Section B recommended alignment is \$55,104,900. A detailed breakout of this OPCC is shown in **Table 48**.



North Texas Municipal Water District

Table 48 – Opinion of Probable Construction Costs

NTMWD Lower Bois d'Arc Creek Reservoir Raw Water Pipeline (Section B)		FREESE AND NICHOLS		1701 N Market St., #500, LB51 • Dallas, Texas 75202 • 214-217-2200 • fax 214-217-2201	
OPINION OF PROBABLE CONSTRUCTION COSTS (INCLUDING EASEMENTS)					
					September 16, 2013
ESTIMATOR		CHECKED BY		ACCOUNT NO	
DWH		JB		NTD13136	
ITEM	DESCRIPTION	QUANTITY	UNIT	UNIT PRICE	TOTAL
1	90-INCH PIPELINE	51,688	LF	\$650.00	\$ 33,537,264
2	TUNNELLED CROSSINGS	551	LF	\$1,970.00	\$ 1,084,520
3	PIPELINE ROW CLEARING	140	AC	\$5,000.00	\$ 700,000
4	TRENCH SAFETY	51,688	LF	\$1.00	\$ 51,688
5	AIR RELEASE VALVES	15	EA	\$25,000.00	\$ 372,500
6	BUTTERFLY VALVES	2	EA	\$165,000.00	\$ 330,000
7	BLOW OFF VALVES	15	EA	\$25,000.00	\$ 372,500
8	PAVEMENT RESTORATION	830	SY	\$70.00	\$ 58,100
9	CREEK CROSSINGS	468	LF	\$445.00	\$ 208,273
10	REVEGETATION	140	AC	\$1,160.00	\$ 162,400
11	FIBER OPTIC CONDUIT	51,688	LF	\$3.00	\$ 155,064
12	FIBER	51,688	LF	\$2.00	\$ 103,376
13	CATHODIC PROTECTION	51,688	LF	\$2.00	\$ 103,376
14	ACCESS MANWAYS	15	LF	\$10,000.00	\$ 149,000
15	TESTING	51,688	LF	\$2.00	\$ 103,376
16	MOBILIZATION	1	LS	\$1,877,572.00	\$ 1,877,572
CONSTRUCTION SUBTOTAL					\$ 39,430,000
CONSTRUCTION CONTINGENCY					\$ 5,914,500
CONSTRUCTION TOTAL					\$ 45,344,500
ESTIMATED EASEMENT/PROPERTY COSTS					
PERMANENT EASEMENT W/ ASSOCIATED TEMPORARY (Note 1)		2,584,405	SF	\$1.00	\$2,584,400.00
TOTAL ESTIMATED COSTS (INCLUDING EASEMENT)					\$47,928,900.00
1. Estimated Easement Costs Based on a 50' Perm Easement & 70' Temp Easement for the Entire Route					

2.3.5 Recommendations Summary

The recommended alignment for Section B is Alternate B for Conflict Area #1, #2, #3, #4, and #6, and Alternate C for Conflict Area #5. Each of these routes is expected to be the least expensive option for their corresponding conflict area. All conflict areas avoid potential complications in land acquisition and construction. Based on the recommended routes the proposed Section B alignment has been shortened from 11.02 miles to 9.89 miles, a savings of 1.13 miles of 90 inch pipeline.

North Texas Municipal Water District

2.3.6 Pipeline Crossings

Table 49 below presents identified utility, roadway, and creek crossings associated with the recommended route.

Table 49– Major Transportation, Utility, and W Crossings

Road
State Highway 56
Fannin CR 3210
Fannin CR 3200
Fannin CR 3205
Farm to Market 2077
Farm to Market 1550
Fannin CR 3302
Fannin CR 3300
Farm to Market 271
Fannin CR 3120
Fannin CR 3115
Farm to Market 68
Railroad
Texas Northeastern Railroad (TNER) - Genesee & Wyoming Inc.
Utility
36" Natural Gas Pipeline - Energy Transfer Company
Waterbody
Bullard Creek Tributary
Long Branch Creek Tributary
Pot Creek
Allen Creek



North Texas Municipal Water District

Table 50 – Conflict Area #1 Alt A Cost Analysis

ALTERNATE A	SEGMENT PARAMETERS			UNIT COSTS		EASEMENT LAND COSTS	CONSTRUCTION COST		
	Type & Description	Length [ft]	Land Class	Instll. Class	Land [\$/ft]		M&I [\$/ft]	Material & Installation [\$]	& Miscellaneous 1 [\$]
Type 1 - Open	6,547	R	1	53.72	656	351,705	4,294,832	136,435	
Type 2 - Wooded	974	R	2	53.72	669	52,323	651,606	20,297	
Type 3 - Creek Crossings	70	R	4	53.72	1094	3,760	76,580	1,459	
Type 4 - Road/Parking Lot Crossings	30	R	5	53.72	1047	1,612	31,410	625	
Type 5 - Bore or Tunnel Crossings	-	R	6	53.72	1900	-	-	-	
Parcel Count ²	5	EA		25000	\$/EA	125,000			
Totals:						7,621	\$534,400	\$5,054,428	\$158,816
							CONSTRUCTION COST	\$5,213,244	
							CONTINGENCY 20%	\$1,042,649	
1. Appurtenances & Miscellaneous - Includes air valves, blow off valves, butterfly valves, etc.							TOTAL CONSTRUCTION COST:	\$6,260,000	
2. This is for ROE and acquisition related costs							TOTAL LAND COST	\$530,000	
							TOTAL ROUTE COST	\$6,790,000	

Table 51 – Conflict Area #1 Alt B Cost Analysis

ALTERNATE B	SEGMENT PARAMETERS			UNIT COSTS		EASEMENT LAND COSTS	CONSTRUCTION COST		
	Type & Description	Length [ft]	Land Class	Instll. Class	Land [\$/ft]		M&I [\$/ft]	Material & Installation [\$]	& Miscellaneous 1 [\$]
Type 1 - Open	5,461	R	1	53.72	656	293,365	3,582,416	113,803	
Type 2 - Wooded	1,340	R	2	53.72	669	71,985	896,460	27,925	
Type 3 - Creek Crossings	207	R	4	53.72	1094	11,120	226,458	4,314	
Type 4 - Road/Parking Lot Crossings	26	R	5	53.72	1047	1,397	27,222	542	
Type 5 - Bore or Tunnel Crossings	-	R	6	53.72	1900	-	-	-	
Parcel Count ²	4	EA		25000	\$/EA	100,000			
Totals:						7,034	\$477,866	\$4,732,556	\$146,584
							CONSTRUCTION COST	\$4,879,140	
							CONTINGENCY 20%	\$975,828	
1. Appurtenances & Miscellaneous - Includes air valves, blow off valves, butterfly valves, etc.							TOTAL CONSTRUCTION COST:	\$5,850,000	
2. This is for ROE and acquisition related costs							TOTAL LAND COST	\$480,000	
							TOTAL ROUTE COST	\$6,330,000	



North Texas Municipal Water District

Table 52 – Conflict Area #1 Alt C Cost Analysis

ALTERNATE C	SEGMENT PARAMETERS			UNIT COSTS		EASEMENT LAND COSTS	CONSTRUCTION COST		
	Type & Description	Length [ft]	Land Class	Instll. Class	Land [\$/ft]		M&I [\$/ft]	Material & Installation [\$]	& Miscellaneous 1 [\$]
Type 1- Open	6,825	R	1	53.72	656	366,639	4,477,200	142,228	
Type 2- Wooded	697	R	2	53.72	669	37,443	466,293	14,525	
Type 3 - Creek Crossings	74	R	4	53.72	1094	3,975	80,956	1,542	
Type 4 - Road/Parking Lot Crossings	30	R	5	53.72	1047	1,612	31,410	625	
Type 5 - Bore or Tunnel Crossings	-	R	6	53.72	1900	-	-	-	
Parcel Count ²	6	EA		25000	\$/EA	150,000			
Totals:						7,626	\$559,669	\$5,055,859	\$158,920
							CONSTRUCTION COST	\$5,214,779	
							CONTINGENCY 20%	\$1,042,956	
							TOTAL CONSTRUCTION COST:	\$6,260,000	
							TOTAL LAND COST	\$560,000	
							TOTAL ROUTE COST	\$6,820,000	

1. Appurtenances & Miscellaneous - Includes air valves, blow off valves, butterfly valves, etc.
 2. This is for ROE and acquisition related costs

Table 53 – Conflict Area #2 Alt A Cost Analysis

ALTERNATE A	SEGMENT PARAMETERS			UNIT COSTS		EASEMENT LAND COSTS	CONSTRUCTION COST		
	Type & Description	Length [ft]	Land Class	Instll. Class	Land [\$/ft]		M&I [\$/ft]	Material & Installation [\$]	& Miscellaneous 1 [\$]
Type 1- Open	5,806	R	1	53.72	656	311,898	3,808,736	120,993	
Type 2- Wooded	1,034	R	2	53.72	669	55,546	691,746	21,548	
Type 3 - Creek Crossings	48	R	4	53.72	1094	2,579	52,512	1,000	
Type 4 - Road/Parking Lot Crossings	-	R	5	53.72	1047	-	-	-	
Type 5 - Bore or Tunnel Crossings	77	R	6	53.72	1900	4,136	146,300	1,605	
Parcel Count ²	3	EA		25000	\$/EA	75,000			
Totals:						6,965	\$449,160	\$4,699,294	\$145,146
							CONSTRUCTION COST	\$4,844,440	
							CONTINGENCY 20%	\$968,888	
							TOTAL CONSTRUCTION COST:	\$5,810,000	
							TOTAL LAND COST	\$450,000	
							TOTAL ROUTE COST	\$6,260,000	

1. Appurtenances & Miscellaneous - Includes air valves, blow off valves, butterfly valves, etc.
 2. This is for ROE and acquisition related costs



North Texas Municipal Water District

Table 54 – Conflict Area #2 Alt B Cost Analysis

ALTERNATE B	SEGMENT PARAMETERS			UNIT COSTS		EASEMENT LAND COSTS	CONSTRUCTION COST	
	Type & Description	Length [ft]	Land Class	Instll. Class	Land [\$/ft]		M&I [\$/ft]	Material & Installation [\$]
Type 1- Open	5,500	R	1	53.72	656	295,460	3,608,000	114,616
Type 2- Wooded	78	R	2	53.72	669	4,190	52,182	1,625
Type 3 - Creek Crossings	-	R	4	53.72	1094	-	-	-
Type 4 - Road/Parking Lot Crossings	-	R	5	53.72	1047	-	-	-
Type 5 - Bore or Tunnel Crossings	-	R	6	53.72	1900	-	-	-
Parcel Count ²	3	EA		25000	\$/EA	75,000		
Totals:		5,578				\$374,650	\$3,660,182	\$116,242
							CONSTRUCTION COST	\$3,776,424
							CONTINGENCY 20%	\$755,285
							TOTAL CONSTRUCTION COST:	\$4,530,000
							TOTAL LAND COST	\$370,000
							TOTAL ROUTE COST	\$4,900,000

1. Appurtenances & Miscellaneous - Includes air valves, blow off valves, butterfly valves, etc.
2. This is for ROE and acquisition related costs

Table 55 – Conflict Area #3 Alt A Cost Analysis

ALTERNATE A	SEGMENT PARAMETERS			UNIT COSTS		EASEMENT LAND COSTS	CONSTRUCTION COST	
	Type & Description	Length [ft]	Land Class	Instll. Class	Land [\$/ft]		M&I [\$/ft]	Material & Installation [\$]
Type 1- Open	5,763	R	1	53.72	656	309,588	3,780,528	120,097
Type 2- Wooded	297	R	2	53.72	669	15,955	198,693	6,189
Type 3 - Creek Crossings	-	R	4	53.72	1094	-	-	-
Type 4 - Road/Parking Lot Crossings	-	R	5	53.72	1047	-	-	-
Type 5 - Bore or Tunnel Crossings	110	R	6	53.72	1900	5,909	209,000	2,292
Parcel Count ²	5	EA		25000	\$/EA	125,000		
Totals:		6,170				\$456,452	\$4,188,221	\$128,578
							CONSTRUCTION COST	\$4,316,799
							CONTINGENCY 20%	\$863,360
							TOTAL CONSTRUCTION COST:	\$5,180,000
							TOTAL LAND COST	\$480,000
							TOTAL ROUTE COST	\$5,640,000

1. Appurtenances & Miscellaneous - Includes air valves, blow off valves, butterfly valves, etc.
2. This is for ROE and acquisition related costs



North Texas Municipal Water District

Table 56 – Conflict Area #3 Alt B Cost Analysis

ALTERNATE B	SEGMENT PARAMETERS			UNIT COSTS		EASEMENT LAND COSTS	CONSTRUCTION COST		
	Type & Description	Length [ft]	Land Class	Instll. Class	Land [\$/ft]		M&I [\$/ft]	Material & Installation [\$]	& Miscellaneous 1 [\$]
Type 1- Open	4,458	R	1	53.72	656	239,484	2,924,448	92,902	
Type 2- Wooded	180	R	2	53.72	669	9,670	120,420	3,751	
Type 3 - Creek Crossings	15	R	4	53.72	1094	806	16,410	313	
Type 4 - Road/Parking Lot Crossings	-	R	5	53.72	1047	-	-	-	
Type 5 - Bore or Tunnel Crossings	105	R	6	53.72	1900	5,641	199,500	2,188	
Parcel Count ²	6	EA		25000	\$/EA	150,000			
Totals:						4,758	\$405,600	\$3,260,778	\$99,153
							CONSTRUCTION COST	\$3,359,931	
							CONTINGENCY 20%	\$671,986	
							TOTAL CONSTRUCTION COST:	\$4,030,000	
							TOTAL LAND COST	\$410,000	
							TOTAL ROUTE COST	\$4,440,000	

1. Appurtenances & Miscellaneous - Includes air valves, blow off valves, butterfly valves, etc.
 2. This is for ROE and acquisition related costs

Table 57 – Conflict Area #3 Alt C Cost Analysis

ALTERNATE C	SEGMENT PARAMETERS			UNIT COSTS		EASEMENT LAND COSTS	CONSTRUCTION COST		
	Type & Description	Length [ft]	Land Class	Instll. Class	Land [\$/ft]		M&I [\$/ft]	Material & Installation [\$]	& Miscellaneous 1 [\$]
Type 1- Open	5,054	R	1	53.72	656	271,501	3,315,424	105,322	
Type 2- Wooded	112	R	2	53.72	669	6,017	74,928	2,334	
Type 3 - Creek Crossings	-	R	4	53.72	1094	-	-	-	
Type 4 - Road/Parking Lot Crossings	-	R	5	53.72	1047	-	-	-	
Type 5 - Bore or Tunnel Crossings	100	R	6	53.72	1900	5,372	190,000	2,084	
Parcel Count ²	6	EA		25000	\$/EA	150,000			
Totals:						5,266	\$432,890	\$3,580,352	\$109,740
							CONSTRUCTION COST	\$3,690,092	
							CONTINGENCY 20%	\$738,018	
							TOTAL CONSTRUCTION COST:	\$4,430,000	
							TOTAL LAND COST	\$430,000	
							TOTAL ROUTE COST	\$4,860,000	

1. Appurtenances & Miscellaneous - Includes air valves, blow off valves, butterfly valves, etc.
 2. This is for ROE and acquisition related costs



North Texas Municipal Water District

Table 58 – Conflict Area #3 Alt D Cost Analysis

ALTERNATE D	SEGMENT PARAMETERS			UNIT COSTS		EASEMENT LAND COSTS	CONSTRUCTION COST	
	Type & Description	Length [ft]	Land Class	Instll. Class	Land [\$/ft]		M&I [\$/ft]	Material & Installation [\$]
Type 1- Open	6,890	R	1	53.72	656	370,131	4,519,840	143,583
Type 2- Wooded	58	R	2	53.72	669	3,116	38,802	1,209
Type 3 - Creek Crossings	36	R	4	53.72	1094	1,934	39,384	750
Type 4 - Road/Parking Lot Crossings	-	R	5	53.72	1047	-	-	-
Type 5 - Bore or Tunnel Crossings	100	R	6	53.72	1900	5,372	190,000	2,084
Parcel Count ²	5	EA		25000	\$/EA	125,000		
Totals:		7,084				\$505,552	\$4,788,026	\$147,626
							CONSTRUCTION COST	\$4,935,652
							CONTINGENCY 20%	\$987,130
							TOTAL CONSTRUCTION COST:	\$5,920,000
							TOTAL LAND COST	\$510,000
							TOTAL ROUTE COST	\$6,430,000
<p>1. Appurtenances & Miscellaneous - Includes air valves, blow off valves, butterfly valves, etc.</p> <p>2. This is for ROE and acquisition related costs</p>								

Table 59 – Conflict Area #4 Alt A Cost Analysis

ALTERNATE A	SEGMENT PARAMETERS			UNIT COSTS		EASEMENT LAND COSTS	CONSTRUCTION COST	
	Type & Description	Length [ft]	Land Class	Instll. Class	Land [\$/ft]		M&I [\$/ft]	Material & Installation [\$]
Type 1- Open	2,850	R	1	53.72	656	153,102	1,869,600	59,392
Type 2- Wooded	53	R	2	53.72	669	2,847	35,457	1,104
Type 3 - Creek Crossings	-	R	4	53.72	1094	-	-	-
Type 4 - Road/Parking Lot Crossings	12	R	5	53.72	1047	645	12,564	250
Type 5 - Bore or Tunnel Crossings	108	R	6	53.72	1900	5,802	205,200	2,251
Parcel Count ²	2	EA		25000	\$/EA	50,000		
Totals:		3,023				\$212,396	\$2,122,821	\$62,997
							CONSTRUCTION COST	\$2,185,818
							CONTINGENCY 20%	\$437,164
							TOTAL CONSTRUCTION COST:	\$2,620,000
							TOTAL LAND COST	\$210,000
							TOTAL ROUTE COST	\$2,830,000
<p>1. Appurtenances & Miscellaneous - Includes air valves, blow off valves, butterfly valves, etc.</p> <p>2. This is for ROE and acquisition related costs</p>								



North Texas Municipal Water District

Table 60 – Conflict Area #4 Alt B Cost Analysis

ALTERNATE B	SEGMENT PARAMETERS			UNIT COSTS		EASEMENT LAND COSTS	CONSTRUCTION COST	
	Type & Description	Length [ft]	Land Class	Instll. Class	Land [\$/ft]		M&I [\$/ft]	Material & Installation [\$]
Type 1- Open	2,003	R	1	53.72	656	107,601	1,313,968	41,741
Type 2- Wooded	39	R	2	53.72	669	2,095	26,091	813
Type 3 - Creek Crossings	-	R	4	53.72	1094	-	-	-
Type 4 - Road/Parking Lot Crossings	13	R	5	53.72	1047	698	13,611	271
Type 5 - Bore or Tunnel Crossings	101	R	6	53.72	1900	5,426	191,900	2,105
Parcel Count ²	2	EA		25000	\$/EA	50,000		
Totals:		2,156				\$165,820	\$1,545,570	\$44,930
							CONSTRUCTION COST	\$1,590,500
							CONTINGENCY 20%	\$318,100
							TOTAL CONSTRUCTION COST:	\$1,910,000
							TOTAL LAND COST	\$170,000
							TOTAL ROUTE COST	\$2,080,000
1. Appurtenances & Miscellaneous - Includes air valves, blow off valves, butterfly valves, etc. 2. This is for ROE and acquisition related costs								

Table 61 – Conflict Area #5 Alt A Cost Analysis

ALTERNATE A	SEGMENT PARAMETERS			UNIT COSTS		EASEMENT LAND COSTS	CONSTRUCTION COST	
	Type & Description	Length [ft]	Land Class	Instll. Class	Land [\$/ft]		M&I [\$/ft]	Material & Installation [\$]
Type 1- Open	15,883	R	1	53.72	656	853,235	10,419,248	330,990
Type 2- Wooded	104	R	2	53.72	669	5,587	69,576	2,167
Type 3 - Creek Crossings	-	R	4	53.72	1094	-	-	-
Type 4 - Road/Parking Lot Crossings	24	R	5	53.72	1047	1,289	25,128	500
Type 5 - Bore or Tunnel Crossings	50	R	6	53.72	1900	2,686	95,000	1,042
Parcel Count ²	7	EA		25000	\$/EA	175,000		
Totals:		16,061				\$1,037,797	\$10,608,952	\$334,700
							CONSTRUCTION COST	\$10,943,652
							CONTINGENCY 20%	\$2,188,730
							TOTAL CONSTRUCTION COST:	\$13,130,000
							TOTAL LAND COST	\$1,040,000
							TOTAL ROUTE COST	\$14,170,000
1. Appurtenances & Miscellaneous - Includes air valves, blow off valves, butterfly valves, etc. 2. This is for ROE and acquisition related costs								



North Texas Municipal Water District

Table 62 – Conflict Area #5 Alt B Cost Analysis

ALTERNATE B	SEGMENT PARAMETERS			UNIT COSTS		EASEMENT LAND COSTS	CONSTRUCTION COST	
	Length [ft]	Land Class	Instll. Class	Land [\$/ft]	M&I [\$/ft]		Material & Installation [\$]	& Miscellaneous 1 [\$]
Type 1 - Open	14,999	R	1	53.72	656	805,746	9,839,344	312,568
Type 2 - Wooded	96	R	2	53.72	669	5,157	64,224	2,001
Type 3 - Creek Crossings	-	R	4	53.72	1094	-	-	-
Type 4 - Road/Parking Lot Crossings	22	R	5	53.72	1047	1,182	23,034	458
Type 5 - Bore or Tunnel Crossings	52	R	6	53.72	1900	2,793	98,800	1,084
Parcel Count ²	8	EA		25000	\$/EA	200,000		
Totals:		15,169				\$1,014,879	\$10,025,402	\$316,111
							CONSTRUCTION COST	\$10,341,513
							CONTINGENCY 20%	\$2,068,303
1. Appurtenances & Miscellaneous - Includes air valves, blow off valves, butterfly valves, etc.							TOTAL CONSTRUCTION COST:	\$12,410,000
2. This is for ROE and acquisition related costs							TOTAL LAND COST	\$1,010,000
							TOTAL ROUTE COST	\$13,420,000

Table 63 – Conflict Area #5 Alt C Cost Analysis

ALTERNATE C	SEGMENT PARAMETERS			UNIT COSTS		EASEMENT LAND COSTS	CONSTRUCTION COST	
	Length [ft]	Land Class	Instll. Class	Land [\$/ft]	M&I [\$/ft]		Material & Installation [\$]	& Miscellaneous 1 [\$]
Type 1 - Open	14,724	R	1	53.72	656	790,973	9,658,944	306,838
Type 2 - Wooded	98	R	2	53.72	669	5,265	65,562	2,042
Type 3 - Creek Crossings	162	R	4	53.72	1094	8,703	177,228	3,376
Type 4 - Road/Parking Lot Crossings	16	R	5	53.72	1047	860	16,752	333
Type 5 - Bore or Tunnel Crossings	54	R	6	53.72	1900	2,901	102,600	1,125
Parcel Count ²	9	EA		25000	\$/EA	225,000		
Totals:		15,054				\$1,033,701	\$10,021,086	\$313,715
							CONSTRUCTION COST	\$10,334,801
							CONTINGENCY 20%	\$2,066,960
1. Appurtenances & Miscellaneous - Includes air valves, blow off valves, butterfly valves, etc.							TOTAL CONSTRUCTION COST:	\$12,400,000
2. This is for ROE and acquisition related costs							TOTAL LAND COST	\$1,030,000
							TOTAL ROUTE COST	\$13,430,000



North Texas Municipal Water District

Table 64 – Conflict Area #6 Alt A Cost Analysis

ALTERNATE A	SEGMENT PARAMETERS			UNIT COSTS		EASEMENT LAND COSTS	CONSTRUCTION COST		
	Type & Description	Length [ft]	Land Class	Instll. Class	Land [\$/ft]		M&I [\$/ft]	Material & Installation [\$]	& Miscellaneous 1 [\$]
Type 1 - Open	4,255	R	1	53.72	656	228,579	2,791,280	88,671	
Type 2 - Wooded	85	R	2	53.72	669	4,566	56,865	1,771	
Type 3 - Creek Crossings	-	R	4	53.72	1094	-	-	-	
Type 4 - Road/Parking Lot Crossings	17	R	5	53.72	1047	913	17,799	354	
Type 5 - Bore or Tunnel Crossings	-	R	6	53.72	1900	-	-	-	
Parcel Count ²	1	EA		25000	\$/EA	25,000			
Totals:						4,357	\$259,058	\$2,865,944	\$90,797
							CONSTRUCTION COST	\$2,956,741	
							CONTINGENCY 20%	\$591,348	
							TOTAL CONSTRUCTION COST:	\$3,550,000	
							TOTAL LAND COST	\$260,000	
							TOTAL ROUTE COST	\$3,810,000	

1. Appurtenances & Miscellaneous - Includes air valves, blow off valves, butterfly valves, etc.
 2. This is for ROE and acquisition related costs

Table 65 – Conflict Area #6 Alt B Cost Analysis

ALTERNATE B	SEGMENT PARAMETERS			UNIT COSTS		EASEMENT LAND COSTS	CONSTRUCTION COST		
	Type & Description	Length [ft]	Land Class	Instll. Class	Land [\$/ft]		M&I [\$/ft]	Material & Installation [\$]	& Miscellaneous 1 [\$]
Type 1 - Open	3,594	R	1	53.72	656	193,070	2,357,664	74,896	
Type 2 - Wooded	42	R	2	53.72	669	2,256	28,098	875	
Type 3 - Creek Crossings	-	R	4	53.72	1094	-	-	-	
Type 4 - Road/Parking Lot Crossings	19	R	5	53.72	1047	1,021	19,893	396	
Type 5 - Bore or Tunnel Crossings	-	R	6	53.72	1900	-	-	-	
Parcel Count ²	1	EA		25000	\$/EA	25,000			
Totals:						3,655	\$221,347	\$2,405,655	\$76,168
							CONSTRUCTION COST	\$2,481,823	
							CONTINGENCY 20%	\$496,365	
							TOTAL CONSTRUCTION COST:	\$2,980,000	
							TOTAL LAND COST	\$220,000	
							TOTAL ROUTE COST	\$3,200,000	

1. Appurtenances & Miscellaneous - Includes air valves, blow off valves, butterfly valves, etc.
 2. This is for ROE and acquisition related costs

2.4 SECTION C

2.4.1 Introduction

Section C of the LBCR Raw Water Pipeline connects with Section B approximately 2.5 miles north of Bailey. The connection is near the intersection of FM 68 and CR 3700, which is slightly less than a mile due east of SH 78. The pipeline alignment ends at the proposed site of the North Water Treatment Plant (NWTP) on the west side of Leonard. Section C is approximately 11 miles long and runs generally southwest.

The original preliminary pipeline corridor was determined in “NTMWD Preliminary Pipeline Routing Study and Conceptual Pump Station Design Report” by completing a high level analysis of pipeline corridors from the proposed LBCR pump station to the proposed NWTP site. The pump station was relocated as a portion of this project, but this did not change the pipeline corridor for Section C. The preliminary alignment was modified to generally parallel existing roads and property lines. Various options were examined at identified conflict areas and additional analysis was completed to take into account costs associated with easements, road crossings, and construction. The analysis discussed in this report details the process of determining the final pipeline alignment from the preliminary alignment and various alternatives developed during this phase of the pipeline route selection.

2.4.2 Evaluation of Corridors

The preliminary alignment corridor for Section C of the LBCR Pipeline northeast of Leonard routed the pipe south along the east side of SH 78 until just before crossing CR 4850 where the pipeline routed west. While investigating potential conflicts, a family cemetery was identified to be in the path of the preliminary alignment. In order to avoid the cemetery and several other potential conflicts along the preliminary alignment, alternates to the West of SH 78 were investigated. The new proposed route alternatives were developed by first finding a SH 78 crossing north of the cemetery, and then determining where was the best location for the new route to connect back with the preliminary pipeline alignment. An alignment was routed around a house on the west side of SH 78 and then traveled through mostly open land before ending at the preliminary alignment. The preliminary alignment was named Proposed Route A and the western cross-country alternative Proposed Route B.

Figure 22, below, shows a map of both proposed routes.



Figure 22 – Map of Proposed Routes

The two corridors developed were compared using a High Level Analysis shown below in **Table 66**. The routes were evaluated based on length, parcel count, wooded crossings length, number of stream crossings, hydric soil crossings, and number of bored crossings. Each item was weighted, and the routes were scored and compared. Proposed Route B is approximately 100 feet shorter than Proposed Route A, crosses fewer parcels, fewer wooded areas, and does not cross a perennial stream. Also, Proposed Route A travels through the family cemetery, within 20 feet of a pond, and within 30 feet of a house. Proposed Route B scored the lowest (Best) in this analysis and was selected as the preferred route.

Table 66 – Weighted High Level Route Scores

Raw Quantities (Low is Best)			
Item Description	Item Weight (High = Most Important) (0 = Not Considered)	Routes	
		Proposed A	Proposed B
Route Length, ft	40	7,863	7,668
Parcel Count, ea	15	9	5
Wooded Crossing, ft	10	523	313
Perennial Stream Crossing, ea	10	1	-
Intermittent Stream Crossing, ea	9	2	2
Hydric Soil Crossing, ft	9	-	-
Bored Crossing (TXDOT & RR), ea	7	1	1
Total	100		
Normalized Score (Low is Best)			
Item Description	Item Weight	Proposed A	Proposed B
Route Length, ft	40.00	40.34	39.34
Parcel Count, ea	15.00	2.25	1.25
Wooded Crossing, ft	10.00	2.49	1.49
Perennial Stream Crossing, ea	10.00	1.00	-
Intermittent Stream Crossing, ea	9.00	1.00	1.00
Hydric Soil Crossing, ft	9.00	1.00	1.00
Bored Crossing (TXDOT & RR), ea	7.00	1.00	1.00
Total	100.00	49.07	45.07
Weighted Score (Low is Best)			
Item Description	Item Weight	Proposed A	Proposed B
Route Length, ft	40.00	16.14	15.74
Parcel Count, ea	15.00	0.34	0.19
Wooded Crossing, ft	10.00	0.25	0.15
Perennial Stream Crossing, ea	10.00	0.10	-
Intermittent Stream Crossing, ea	9.00	0.09	0.09
Hydric Soil Crossing, ft	9.00	0.09	0.09
Bored Crossing (TXDOT & RR), ea	7.00	0.07	0.07
Total	100.00	17.07	16.32

2.4.3 Route Alternatives

The preliminary pipeline alignment corridor was investigated further in order to identify potential conflict areas along the route. Conflicts were determined based upon aerial imagery and field work walking the potential pipeline routes. A detailed evaluation of localized alternatives was performed to optimize the pipeline alignment and avoid potential conflicts in land acquisition and construction. Environmental constraints such as stream crossings, perennial water bodies, and possible wetlands along with impacts to property owners were taken into account during the analysis.

Four main conflict areas were identified on the potential pipeline route. The first conflict area is south of FM 68 along CR 3700, which is the beginning of Section C. The preliminary pipeline alignment routed in front of a house. An alternate was included to route the pipeline on the other side of the road to avoid complications with land acquisition. The second conflict area is near the intersection of CR 3700 and FM 1552. The original alignment routed close to a house and would require several fittings to follow property lines. A new alternative was developed to shorten up the alignment and avoid passing close by to the house. The third conflict area is located directly south of Bailey where the pipeline travels between FM 816 and SH 78. The preliminary alignment heads due west following property lines. Other alternatives were evaluated to travel through open land and avoid a large wooded creek area just east of SH 78. Also, this conflict area was used to determine the best location to cross to the west side of SH 78. The fourth conflict area is located between FM 1553 and CR 4670. The preliminary pipeline follows property lines and existing overhead electric lines. An alternate route was developed to cross through open land and minimize the pipeline route.

The preferred alternatives were determined by analysis that compared the total length, number of parcels crossed, open cut length, wooded length, tunnel length, construction cost, and land acquisition cost. The recommended alignment was chosen based on the cost analysis completed and engineering judgment. The detailed route analysis of these four conflict areas is discussed below.

2.4.4 Detailed Route Analysis

In order to properly analyze the various alternatives developed for the conflict areas, data was collected and input into a pipeline route evaluation criteria spreadsheet. Cost data was updated to estimate future pipeline construction costs based on recent bid information. Routes were classified by the type

North Texas Municipal Water District

of land they would be installed in: open area, wooded, open cut creek crossings, open cut road crossings, or tunneled crossings. A construction cost and land acquisition cost was associated with each classification in order to estimate the total route cost per linear foot. This allowed a cost to be generated for each alternate based upon the linear feet of the land classification. A cost comparison was performed for the alternates of each conflict area to determine the most cost effective route. The route with the lowest cost was selected as the preferred route; however, engineering judgment was also used to ensure that potential complications with an unknown cost were also evaluated.

Conflict Area #1 was identified because of the proximity of the pipeline alignment to a house on the east side of CR 3115 as seen in **Figure 23**. Two alternatives were analyzed for this conflict area.

Alternate A paralleled the east side of CR 3700. Alternate B paralleled the west side of CR 3700. Analysis of Conflict Area #1 is shown in **Table 67**.



Figure 23 – Aerial View of Conflict Area #1

Table 67 – Analysis for Conflict Area #1

Option	Alternate A	Alternate B
Length	8435	8328
Number of Parcels	8	6
Open Length (ft.)	8435	8192
Wooded Length (ft.)	0	136
Tunnel/Bore Length	0	0
Construction Cost	\$6,860,000	\$6,780,000
Land Acquisition Cost	\$650,000	\$600,000
Total Cost	\$7,510,000	\$7,380,000

*For further cost analysis data see **Tables 73 & 74**

North Texas Municipal Water District

From the analysis performed, Alternate A and B are very similar in construction cost, but Alternate B is recommended. Alternate B is approximately 100 feet shorter than Alternate A and has a lower total cost. Also, Alternate B avoids construction near the house on the east side of CR 3700.

Conflict Area #2 was identified because of the possibility to minimize pipeline fittings and move the route a greater distance from the house on FM 1552. Two alternatives were analyzed for this conflict area and can be seen in **Figure 24**.

Alternate A routed the pipeline parallel to the north side of FM 1552 before crossing south and following property lines. Alternate B crossed FM 1552 on the west side of the intersection with CR 3700 and routed the pipe across an open field, bisecting two properties. Analysis of Conflict Area #2 is shown in **Table 68**.



Figure 24 – Aerial View of Conflict Area #2

Table 68 – Analysis for Conflict Area #2

Option	Alternate A	Alternate B
Length	3759	2879
Number of Parcels	3	3
Open Length (ft.)	3485	2777
Wooded Length (ft.)	223	52
Tunnel/Bore Length	51	50
Construction Cost	\$3,160,000	\$2,440,000
Land Acquisition Cost	\$280,000	\$230,000
Total Cost	\$3,440,000	\$3,670,000

*For further cost analysis data see **Tables 75 & 76**.

Alternate B was selected as the recommended route due to the fact it is the shorter alternative and would give the contractor more distance from the house on FM 1552. Alternate B is the less expensive approach even though it bisects two parcels, while Alternate A follows property lines. In addition to being longer, Alternate A would require land acquisition from three landowners, while only two would be required for Alternate B.

Conflict Area #3 was investigated to determine the best route to align the pipe south of the city of Bailey. As shown in **Figure 25**, the area has several creek crossings, large wooded areas, and structures within a close distance to the SH 78 right-of-way. Five route alternatives were analyzed for this conflict area.



Figure 25 – Aerial View of Conflict Area #3

Alternate A proposed to align the pipe along property lines heading due west before crossing a creek and large wooded area in order to parallel the east side of SH 78. Alternate B traveled through open land on two properties before following property lines while heading due west to parallel the east side of SH 78. Alternate C routed through open land, bisecting several properties in order to avoid conflicts

North Texas Municipal Water District

along SH 78. Alternate D followed the first half of Alternate A before crossing to the west side of SH 78 to avoid a house on the east ROW line. Alternate E crossed through open land and then followed the alignment of Alternate D. Analysis of Conflict Area #3 is shown in **Table 69**.

Table 69 – Analysis for Conflict Area #3

Option	Alternate A	Alternate B	Alternate C	Alternate D	Alternate E
Length	18859	19312	18671	18787	17251
Number of Parcels	19	18	18	16	16
Open Length (ft.)	16546	18270	17358	16947	16583
Wooded Length (ft.)	1944	678	1079	1674	504
Tunnel/Bore Length	369	364	234	165	164
Construction Cost	\$16,300,000	\$16,410,000	\$15,730,000	\$15,790,000	\$14,490,000
Land Acquisition Cost	\$1,490,000	\$1,490,000	\$1,450,000	\$1,410,000	\$1,330,000
Total Cost	\$17,790,00	\$17,900,000	\$17,180,000	\$17,200,000	\$15,820,000

*For further cost analysis data see **Tables 77-81**.

Alternate E is the recommended route because it is the shortest option, the least expensive, and successfully bypasses the majority of the conflicts. Alternate D is one of the shorter options and follows property lines, but is more expensive than Alternate E. Alternate C is the second shortest alternative, but has a high potential increase in land acquisition cost due to bisecting smaller properties. Neither Alternate A nor B avoids the house on the east ROW line, which could result in higher construction and land acquisition costs.

Conflict Area #4 was identified in order to find the best route around the north side of Leonard and avoid several houses in the area. Two alternates were analyzed for this conflict area and can be found in **Figure 26**.



Figure 26 – Aerial View of Conflict Area #4

North Texas Municipal Water District

Alternate A traveled through open farmland, followed the edge of a field, and then aligned parallel to CR 4670 as it headed west. Alternate B routed west parallel to property lines to the north and then angled south parallel to overhead electric lines until just north of CR 4670. Analysis of Conflict Area #4 is shown in **Table 70**.

Table 70 – Analysis for Conflict Area #4

Option	Alternate A	Alternate B
Length	6940	8593
Number of Parcels	4	7
Open Length (ft.)	6817	8463
Wooded Length (ft.)	44	0
Tunnel/Bore Length	80	130
Construction Cost	\$5,770,000	\$7,170,000
Land Acquisition Cost	\$470,000	\$640,000
Total Cost	\$6,240,000	\$7,810,000

*For further cost analysis data see **Tables 82 & 83**.

Alternate A is the recommended route since it is significantly shorter and maintains a greater distance from houses in the area than Alternate B. Alternate B follows property lines and overhead electric lines, but routes within 50 feet of a pond, 150 feet of a house, and adds length to follow property lines. Alternate B crosses three more parcels, but Alternate A bisects several properties.

2.4.5 Opinion of Probable Construction Cost

The Opinion of Probable Construction Cost (OPCC) for the Section C recommended alignment is \$61,243,100. A detailed breakout of this OPCC is shown in **Table 71**.



North Texas Municipal Water District

Table 71 – Opinion of Probable Construction Costs

NTMWD Lower Bois d'Arc Creek Reservoir Raw Water Pipeline	FREESE NICHOLS	Innovative engineering Practical results Outstanding service www.freese.com
1701 N Market St., #500, LD51 • Dallas, Texas 75202 • 214-217-2200 • fax 214-217-2201		

OPINION OF PROBABLE CONSTRUCTION COSTS (INCLUDING EASEMENTS) September 10, 2013

ESTIMATOR	CHECKED BY	ACCOUNT NO
EJE	JVW	NTD13136

ITEM	DESCRIPTION	QUANTITY	UNIT	UNIT PRICE	TOTAL
1	90-INCH PIPELINE	56,462	LF	\$650.00	\$ 36,700,300
2	TUNNELED CROSSINGS	749	LF	\$1,970.00	\$ 1,475,530
3	PIPELINE ROW CLEARING	350	AC	\$5,000.00	\$ 750,000
4	TRENCH SAFETY	56,462	LF	\$1.00	\$ 56,462
5	AIR RELEASE VALVES	16	EA	\$25,000.00	\$ 407,500
6	BUTTERFLY VALVES	5	EA	\$165,000.00	\$ 825,000
7	BLOW OFF VALVES	16	EA	\$25,000.00	\$ 407,500
8	PAVEMENT RESTORATION	1,160	SY	\$70.00	\$ 81,200
9	CREEK CROSSINGS	752	LF	\$445.00	\$ 334,640
10	REVEGETATION	350	AC	\$1,160.00	\$ 174,000
11	FIBER OPTIC CONDUIT	56,462	LF	\$3.00	\$ 169,386
12	FIBER	56,462	LF	\$2.00	\$ 112,924
13	CATHODIC PROTECTION	56,462	LF	\$2.00	\$ 112,924
14	ACCESS MANNWAYS	16	EA	\$10,000.00	\$ 163,000
15	TESTING	56,462	LF	\$2.00	\$ 112,924
16	MOBILIZATION	1	LS	\$2,094,165.00	\$ 2,094,165

CONSTRUCTION SUBTOTAL		\$ 41,930,000
CONSTRUCTION CONTINGENCY	15%	\$ 6,289,500
CONSTRUCTION TOTAL		\$ 48,219,500

ESTIMATED EASEMENT/PROPERTY COSTS			
PERMANENT EASEMENT W/ ASSOCIATED TEMPORARY (Note 1)	2,823,100	SF	\$1.00 \$2,823,100.00

TOTAL ESTIMATED CONSTRUCTION COSTS (INCLUDING EASEMENT) \$53,400,100.00

1. Estimated Easement Costs Based on a 50' Perm Easement & 70' Temp Easement for the Entire Route
2. Estimated Butterfly Valves includes valves for the Terminal Storage Reservoir

2.4.6 Recommendations Summary

The recommended alignment for Section C is Alternate B for Conflict Area #1 and #2, Alternate D for Conflict Area #3, Alternate A for Conflict Area #4, and Proposed Route B for the two high level corridors evaluated. Each of these routes is expected to be the least expensive option for their corresponding Conflict Area and also avoid potential complications in land acquisition and construction.

North Texas Municipal Water District

2.4.7 Pipeline Crossings

Table 72 below presents identified utility, roadway, and creek crossings associated with the recommended route.

Table 72 – Major Transportation, Utility, and Creek Crossings

Road
Farm to Market 1552
Fannin CR 3725
State Highway 11
Farm to Market 816
Fannin CR 4845
State Highway 78
Fannin CR 4827
Fannin CR 4825
Fannin CR 4830
Farm to Market 1553
Fannin CR 4720
Farm to Market 896
Fannin CR 4670
State Highway 69
Fannin CR 4965
Railroad
M. K. & T. Railroad – Union Pacific
Utility
28" Petroleum Pipeline - Explorer Pipeline Company
Sanitary Sewer Line - City of Bailey
Waterbody
Spring Creek
Loring Creek
Mustang Creek
South Sulphur River



North Texas Municipal Water District

Table 73 – Conflict Area #1 Alt A Cost Analysis

ALTERNATE A	SEGMENT PARAMETERS			UNIT COSTS		EASEMENT LAND COSTS	CONSTRUCTION COST		
	Type & Description	Length (ft)	Land Class	Instll. Class	Land [\$/ft]		M&I [\$/ft]	Material & Installation [\$]	& Miscellaneous 1 [\$]
Type 1 - Open	8,420	R	1	53.72	656	452,322	5,523,520	175,467	
Type 2 - Wooded	-	R	2	53.72	669	-	-	-	
Type 3 - Creek Crossings	-	R	4	53.72	1094	-	-	-	
Type 4 - Road/Parking Lot Crossings	15	R	5	53.72	1047	806	15,705	313	
Type 5 - Bore or Tunnel Crossings	-	R	6	53.72	1900	-	-	-	
Parcel Count ²	8	EA		25000	\$/EA	200,000			
Totals:						8,435	\$653,128	\$5,539,225	\$175,779
							CONSTRUCTION COST	\$5,715,004	
							CONTINGENCY 20%	\$1,143,001	
1. Appurtenances & Miscellaneous - Includes air valves, blow off valves, butterfly valves, etc.							TOTAL CONSTRUCTION COST:	\$6,860,000	
2. This is for ROE and acquisition related costs							TOTAL LAND COST	\$650,000	
							TOTAL ROUTE COST	\$7,510,000	

Table 74 – Conflict Area #1 Alt B Cost Analysis

ALTERNATE B	SEGMENT PARAMETERS			UNIT COSTS		EASEMENT LAND COSTS	CONSTRUCTION COST		
	Type & Description	Length (ft)	Land Class	Instll. Class	Land [\$/ft]		M&I [\$/ft]	Material & Installation [\$]	& Miscellaneous 1 [\$]
Type 1 - Open	8,165	R	1	53.72	656	438,624	5,356,240	170,153	
Type 2 - Wooded	136	R	2	53.72	669	7,306	90,984	2,834	
Type 3 - Creek Crossings	-	R	4	53.72	1094	-	-	-	
Type 4 - Road/Parking Lot Crossings	28	R	5	53.72	1047	1,504	29,316	584	
Type 5 - Bore or Tunnel Crossings	-	R	6	53.72	1900	-	-	-	
Parcel Count ²	6	EA		25000	\$/EA	150,000			
Totals:						8,329	\$597,434	\$5,476,540	\$173,570
							CONSTRUCTION COST	\$5,650,110	
							CONTINGENCY 20%	\$1,130,022	
1. Appurtenances & Miscellaneous - Includes air valves, blow off valves, butterfly valves, etc.							TOTAL CONSTRUCTION COST:	\$6,780,000	
2. This is for ROE and acquisition related costs							TOTAL LAND COST	\$600,000	
							TOTAL ROUTE COST	\$7,380,000	



North Texas Municipal Water District

Table 75 – Conflict Area #2 Alt A Cost Analysis

ALTERNATE A	SEGMENT PARAMETERS			UNIT COSTS		EASEMENT LAND COSTS	CONSTRUCTION COST		
	Type & Description	Length [ft]	Land Class	Instll. Class	Land [\$/ft]		M&I [\$/ft]	Material & Installation [\$]	& Miscellaneous 1 [\$]
Type 1- Open	3,485	R	1	53.72	656	187,214	2,286,160	72,625	
Type 2- Wooded	174	R	2	53.72	669	9,347	116,406	3,626	
Type 3 - Creek Crossings	49	R	4	53.72	1094	2,632	53,606	1,021	
Type 4 - Road/Parking Lot Crossings	-	R	5	53.72	1047	-	-	-	
Type 5 - Bore or Tunnel Crossings	51	R	6	53.72	1900	2,740	96,900	1,063	
Parcel Count ²	3	EA		25000	\$/EA	75,000			
Totals:						3,759	\$276,933	\$2,553,072	\$78,335
							CONSTRUCTION COST	\$2,631,407	
							CONTINGENCY 20%	\$526,281	
1. Appurtenances & Miscellaneous - Includes air valves, blow off valves, butterfly valves, etc.							TOTAL CONSTRUCTION COST:	\$3,160,000	
2. This is for ROE and acquisition related costs							TOTAL LAND COST	\$280,000	
							TOTAL ROUTE COST	\$3,440,000	

Table 76 – Conflict Area #2 Alt B Cost Analysis

ALTERNATE B	SEGMENT PARAMETERS			UNIT COSTS		EASEMENT LAND COSTS	CONSTRUCTION COST		
	Type & Description	Length [ft]	Land Class	Instll. Class	Land [\$/ft]		M&I [\$/ft]	Material & Installation [\$]	& Miscellaneous 1 [\$]
Type 1- Open	2,777	R	1	53.72	656	149,180	1,821,712	57,871	
Type 2- Wooded	-	R	2	53.72	669	-	-	-	
Type 3 - Creek Crossings	52	R	4	53.72	1094	2,793	56,888	1,064	
Type 4 - Road/Parking Lot Crossings	-	R	5	53.72	1047	-	-	-	
Type 5 - Bore or Tunnel Crossings	50	R	6	53.72	1900	2,686	95,000	1,042	
Parcel Count ²	3	EA		25000	\$/EA	75,000			
Totals:						2,879	\$229,660	\$1,973,600	\$59,996
							CONSTRUCTION COST	\$2,033,596	
							CONTINGENCY 20%	\$406,719	
1. Appurtenances & Miscellaneous - Includes air valves, blow off valves, butterfly valves, etc.							TOTAL CONSTRUCTION COST:	\$2,440,000	
2. This is for ROE and acquisition related costs							TOTAL LAND COST	\$230,000	
							TOTAL ROUTE COST	\$2,670,000	



North Texas Municipal Water District

Table 77 – Conflict Area #3 Alt A Cost Analysis

ALTERNATE A	SEGMENT PARAMETERS			UNIT COSTS		EASEMENT LAND COSTS	CONSTRUCTION COST	
	Type & Description	Length (ft)	Land Class	Instll. Class	Land [\$/ft]		M&I [\$/ft]	Material & Installation [\$]
Type 1- Open	16,329	R	1	53.72	656	877,194	10,711,824	340,285
Type 2- Wooded	1,368	R	2	53.72	669	73,489	915,192	28,508
Type 3 - Creek Crossings	576	R	4	53.72	1094	30,943	630,144	12,003
Type 4 - Road/Parking Lot Crossings	218	R	5	53.72	1047	11,711	228,246	4,543
Type 5 - Bore or Tunnel Crossings	369	R	6	53.72	1900	19,823	701,100	7,690
Parcel Count ²	19	EA		25000	\$/EA	475,000		
Totals:		18,860				\$1,488,159	\$13,186,506	\$393,029
							CONSTRUCTION COST	\$13,579,535
							CONTINGENCY 20%	\$2,715,907
							TOTAL CONSTRUCTION COST:	\$16,300,000
							TOTAL LAND COST	\$1,490,000
							TOTAL ROUTE COST	\$17,790,000
1. Appurtenances & Miscellaneous - Includes air valves, blow off valves, butterfly valves, etc. 2. This is for ROE and acquisition related costs								

Table 78 – Conflict Area #3 Alt B Cost Analysis

ALTERNATE B	SEGMENT PARAMETERS			UNIT COSTS		EASEMENT LAND COSTS	CONSTRUCTION COST	
	Type & Description	Length (ft)	Land Class	Instll. Class	Land [\$/ft]		M&I [\$/ft]	Material & Installation [\$]
Type 1- Open	18,125	R	1	53.72	656	973,675	11,890,000	377,712
Type 2- Wooded	483	R	2	53.72	669	25,947	323,127	10,065
Type 3 - Creek Crossings	195	R	4	53.72	1094	10,475	213,330	4,064
Type 4 - Road/Parking Lot Crossings	144	R	5	53.72	1047	7,736	150,768	3,001
Type 5 - Bore or Tunnel Crossings	364	R	6	53.72	1900	19,554	691,600	7,586
Parcel Count ²	18	EA		25000	\$/EA	450,000		
Totals:		19,311				\$1,487,387	\$13,268,825	\$402,427
							CONSTRUCTION COST	\$13,671,252
							CONTINGENCY 20%	\$2,734,250
							TOTAL CONSTRUCTION COST:	\$16,410,000
							TOTAL LAND COST	\$1,490,000
							TOTAL ROUTE COST	\$17,900,000
1. Appurtenances & Miscellaneous - Includes air valves, blow off valves, butterfly valves, etc. 2. This is for ROE and acquisition related costs								



North Texas Municipal Water District

Table 79 – Conflict Area #3 Alt C Cost Analysis

ALTERNATE C	SEGMENT PARAMETERS			UNIT COSTS		EASEMENT LAND COSTS	CONSTRUCTION COST	
	Type & Description	Length [ft]	Land Class	Instll. Class	Land [\$/ft]		M&I [\$/ft]	Material & Installation [\$]
Type 1 - Open	17,242	R	1	53.72	656	926,240	11,310,752	359,311
Type 2 - Wooded	794	R	2	53.72	669	42,654	531,186	16,546
Type 3 - Creek Crossings	285	R	4	53.72	1094	15,310	311,790	5,939
Type 4 - Road/Parking Lot Crossings	116	R	5	53.72	1047	6,232	121,452	2,417
Type 5 - Bore or Tunnel Crossings	234	R	6	53.72	1900	12,570	444,600	4,876
Parcel Count ²	18	EA		25000	\$/EA	450,000		
Totals:		18,671				\$1,453,006	\$12,719,780	\$389,090
							CONSTRUCTION COST	\$13,108,870
							CONTINGENCY 20%	\$2,621,774
1. Appurtenances & Miscellaneous - Includes air valves, blow off valves, butterfly valves, etc.							TOTAL CONSTRUCTION COST:	\$15,730,000
2. This is for ROE and acquisition related costs							TOTAL LAND COST	\$1,450,000
							TOTAL ROUTE COST	\$17,180,000

Table 80 – Conflict Area #3 Alt D Cost Analysis

ALTERNATE D	SEGMENT PARAMETERS			UNIT COSTS		EASEMENT LAND COSTS	CONSTRUCTION COST	
	Type & Description	Length [ft]	Land Class	Instll. Class	Land [\$/ft]		M&I [\$/ft]	Material & Installation [\$]
Type 1 - Open	16,852	R	1	53.72	656	905,289	11,054,912	351,184
Type 2 - Wooded	1,246	R	2	53.72	669	66,935	833,574	25,966
Type 3 - Creek Crossings	428	R	4	53.72	1094	22,992	468,232	8,919
Type 4 - Road/Parking Lot Crossings	96	R	5	53.72	1047	5,157	100,512	2,001
Type 5 - Bore or Tunnel Crossings	165	R	6	53.72	1900	8,864	313,500	3,438
Parcel Count ²	16	EA		25000	\$/EA	400,000		
Totals:		18,787				\$1,409,238	\$12,770,730	\$391,508
							CONSTRUCTION COST	\$13,162,238
							CONTINGENCY 20%	\$2,632,448
1. Appurtenances & Miscellaneous - Includes air valves, blow off valves, butterfly valves, etc.							TOTAL CONSTRUCTION COST:	\$15,790,000
2. This is for ROE and acquisition related costs							TOTAL LAND COST	\$1,410,000
							TOTAL ROUTE COST	\$17,200,000



North Texas Municipal Water District

Table 81 – Conflict Area #3 Alt E Cost Analysis

ALTERNATE E	SEGMENT PARAMETERS			UNIT COSTS		EASEMENT LAND COSTS	CONSTRUCTION COST		
	Type & Description	Length [ft]	Land Class	Instll. Class	Land [\$/ft]		M&I [\$/ft]	Material & Installation [\$]	& Miscellaneous 1 [\$]
Type 1- Open	16,494	R	1	53.72	656	886,058	10,820,064	343,723	
Type 2- Wooded	138	R	2	53.72	669	7,413	92,322	2,876	
Type 3 - Creek Crossings	366	R	4	53.72	1094	19,662	400,404	7,627	
Type 4 - Road/Parking Lot Crossings	89	R	5	53.72	1047	4,781	93,183	1,855	
Type 5 - Bore or Tunnel Crossings	164	R	6	53.72	1900	8,810	311,600	3,418	
Parcel Count ²	16	EA		25000	\$/EA	400,000			
Totals:						17,251	\$1,326,724	\$11,717,573	\$359,499
							CONSTRUCTION COST	\$12,077,072	
							CONTINGENCY 20%	\$2,415,414	
							TOTAL CONSTRUCTION COST:	\$14,490,000	
							TOTAL LAND COST	\$1,330,000	
							TOTAL ROUTE COST	\$15,820,000	
<p>1. Appurtenances & Miscellaneous - Includes air valves, blow off valves, butterfly valves, etc.</p> <p>2. This is for ROE and acquisition related costs</p>									

Table 82 – Conflict Area #4 Alt A Cost Analysis

ALTERNATE A	SEGMENT PARAMETERS			UNIT COSTS		EASEMENT LAND COSTS	CONSTRUCTION COST		
	Type & Description	Length [ft]	Land Class	Instll. Class	Land [\$/ft]		M&I [\$/ft]	Material & Installation [\$]	& Miscellaneous 1 [\$]
Type 1- Open	6,794	R	1	53.72	656	364,974	4,456,864	141,582	
Type 2- Wooded	44	R	2	53.72	669	2,364	29,436	917	
Type 3 - Creek Crossings	-	R	4	53.72	1094	-	-	-	
Type 4 - Road/Parking Lot Crossings	23	R	5	53.72	1047	1,236	24,081	479	
Type 5 - Bore or Tunnel Crossings	80	R	6	53.72	1900	4,298	152,000	1,667	
Parcel Count ²	4	EA		25000	\$/EA	100,000			
Totals:						6,941	\$472,871	\$4,662,381	\$144,645
							CONSTRUCTION COST	\$4,807,026	
							CONTINGENCY 20%	\$961,405	
							TOTAL CONSTRUCTION COST:	\$5,770,000	
							TOTAL LAND COST	\$470,000	
							TOTAL ROUTE COST	\$6,240,000	
<p>1. Appurtenances & Miscellaneous - Includes air valves, blow off valves, butterfly valves, etc.</p> <p>2. This is for ROE and acquisition related costs</p>									



North Texas Municipal Water District

Table 83 – Conflict Area #4 Alt B Cost Analysis

ALTERNATE B Type & Description	SEGMENT PARAMETERS			UNIT COSTS		EASEMENT LAND COSTS [\$]	CONSTRUCTION COST	
	Length [ft]	Land Class	Instll. Class	Land [\$/ft]	M&I [\$/ft]		Material & Installation [\$]	& Miscellaneous 1 [\$]
Type 1 - Open	8,463	R	1	53.72	656	454,632	5,551,728	176,363
Type 2 - Wooded	-	R	2	53.72	669	-	-	-
Type 3 - Creek Crossings	-	R	4	53.72	1094	-	-	-
Type 4 - Road/Parking Lot Crossings	-	R	5	53.72	1047	-	-	-
Type 5 - Bore or Tunnel Crossings	130	R	6	53.72	1900	6,984	247,000	2,709
Parcel Count ²	7	EA		25000	\$/EA	175,000		
Totals:		8,593				\$636,616	\$5,798,728	\$179,072
							CONSTRUCTION COST	\$5,977,800
							CONTINGENCY 20%	\$1,195,560
							TOTAL CONSTRUCTION COST:	\$7,170,000
							TOTAL LAND COST	\$640,000
							TOTAL ROUTE COST	\$7,810,000

1. Appurtenances & Miscellaneous - Includes air valves, blow off valves, butterfly valves, etc.
2. This is for ROE and acquisition related costs

2.5 LBCR RAW WATER PIPELINE FINAL ALIGNMENT

2.5.1 Alignment Summary

The entire recommended alignment for the LBCR Raw Water Pipeline from the Proposed Pump Station to the Terminal Storage Reservoir is shown in **Figure 27**. Although not all alternates selected for the various conflict areas are the least expensive, all of the routes were chosen based on a balance between landowner impact, constructability and cost. Based on the recommended routes the total length of the preferred alignment for the LBCR Raw Water Pipeline is 36.08 miles.

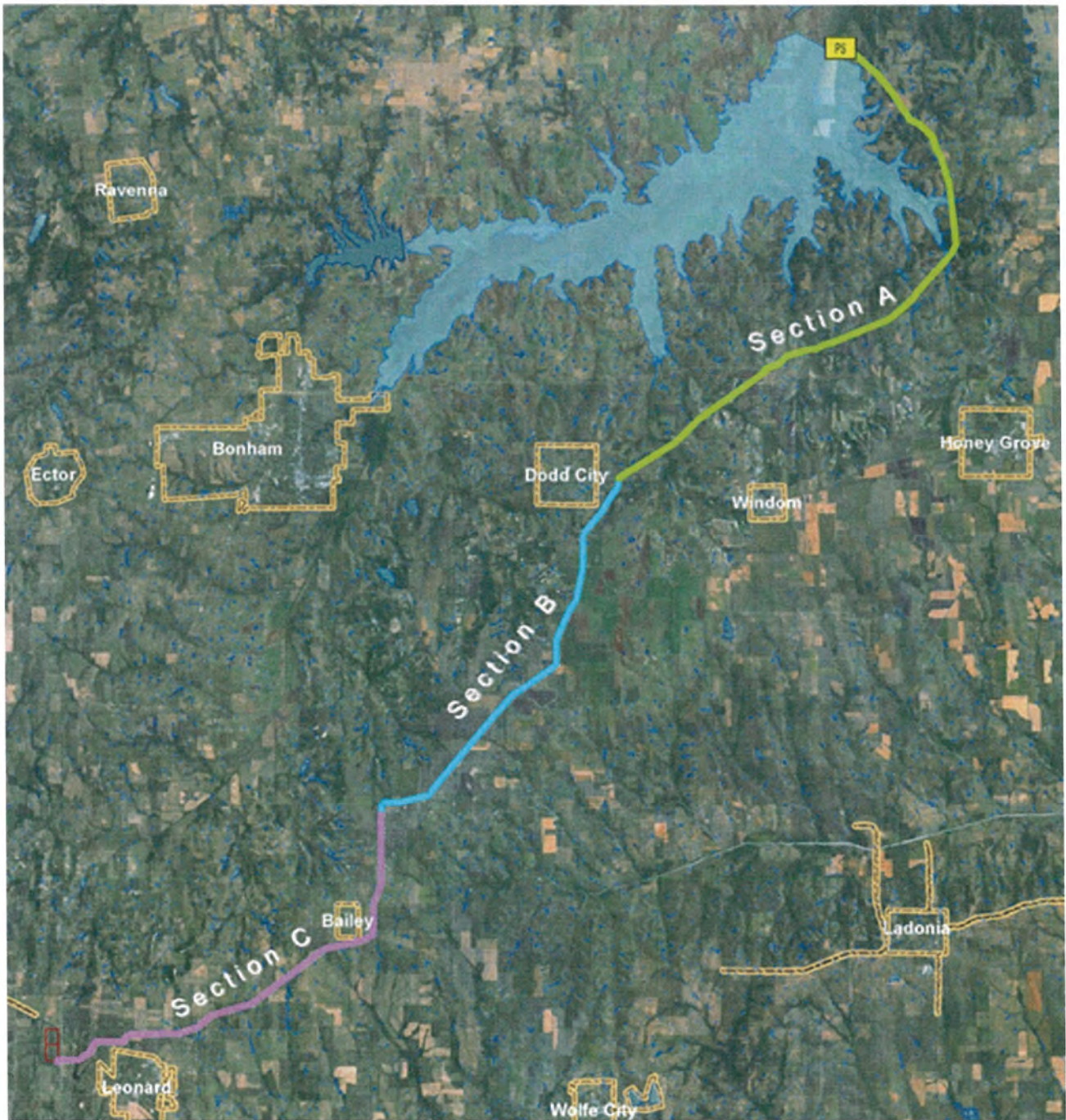

Figure 27 – LBCR Overall Recommended Alignment



North Texas Municipal Water District

2.5.2 Opinion of Probable Construction Cost

The OPCC for the entire recommended alignment of the LBCR Raw Water Pipeline as described below is \$197,926,510. A detailed breakdown of the OPCC for the recommended alignment is shown below in

Table 84.

Table 84 – Final Alignment Opinion of Probable Costs

NTMWD Lower Bois d'Arc Creek Reservoir Raw Water Pipeline		FREESE NICHOLS AND ASSOCIATES		PROFESSIONAL ENGINEERS PLUMBERS CONSTRUCTORS	
1701 N Market St., #900, LD51 • Dallas, Texas 75202 • 214-217-2200 • fax 214-217-2201		www.freese.com			
OPINION OF PROBABLE CONSTRUCTION COSTS (INCLUDING EASEMENTS)					November 25, 2013
ESTIMATOR		CHECKED BY		ACCOUNT NO	
ABC		ASM		NTD13136	
ITEM	DESCRIPTION	QUANTITY	UNIT	UNIT PRICE	TOTAL
1	90-INCH PIPELINE	186,267	LF	\$650.00	\$ 123,073,550
2	TUNNELED CROSSINGS	1,530	LF	\$1,970.00	\$ 3,014,100
3	PIPELINE ROW CLEARING	500	AC	\$5,000.00	\$ 2,500,000
4	TRENCH SAFETY	186,267	LF	\$1.00	\$ 186,267
5	AIR RELEASE VALVES	54	EA	\$25,000.00	\$ 1,350,000
6	BUTTERFLY VALVES	10	EA	\$165,000.00	\$ 1,650,000
7	BLOW OFF VALVES	54	EA	\$25,000.00	\$ 1,350,000
8	PAVEMENT RESTORATION	3,370	SY	\$70.00	\$ 235,900
9	CREEK CROSSINGS	2,728	LF	\$445.00	\$ 1,213,960
10	REVEGETATION	500	AC	\$1,160.00	\$ 580,000
11	FIBER OPTIC CONDUIT	186,267	LF	\$3.00	\$ 558,801
12	FIBER	186,267	LF	\$2.00	\$ 372,534
13	CATHODIC PROTECTION	186,267	LF	\$2.00	\$ 372,534
14	ACCESS MAINWAYS	54	EA	\$10,000.00	\$ 540,000
15	TESTING	186,267	LF	\$2.00	\$ 372,534
16	MOBILIZATION	1	LS	\$6,768,509.00	\$ 6,768,509
CONSTRUCTION SUBTOTAL					\$ 142,146,050
CONSTRUCTION CONTINGENCY					19%
CONSTRUCTION TOTAL					\$ 169,491,000
ESTIMATED EASEMENT/PROPERTY COSTS					
PERMANENT EASEMENT W/ ASSOCIATED TEMPORARY (Note 1)		8,602,000	SF	\$1.00	\$8,602,010
TOTAL ESTIMATED COSTS (INCLUDING EASEMENT)					\$172,063,010

1. Estimated Easement Costs are based on a 50' Permanent Easement & 70' Temporary Easement for the entire route. This total excludes the length of pipe on land currently owned by NTMWD.

3.0 PRELIMINARY SYSTEM HYDRAULICS AND PIPE DIAMETERS

An initial hydraulic analysis was conducted to determine the required pipeline diameter and potential pump station sizing for the project. Hydraulic grade lines (HGLs) were developed for various pipe diameters and flow rates using the routes described in **Section 2.0** and TNRIS 10-foot interval contour data. A 50-year Life Cycle Cost Analysis (LCCA) was performed to determine the most economical pipe diameter.

3.1 FLOW RATE ANALYSIS

3.1.1 LBCR Permitted Diversions

The Lower Bois d'Arc Creek Reservoir is permitted expected to be with an annual yield of 123,200 acre-feet per year in 2060. Converted into an annual average, this equates to a pumping rate of approximately 110 million gallons per day (MGD). The maximum permitted diversion amount is 175,000 acre-feet per year (157 MGD annual average).

3.1.2 Design Flow Rates

The raw water pumping facilities will be designed with the capacity to pump the full yield of the reservoir with additional capacity to account for seasonal peak demands. For design purposes, a 1.5 peaking factor was applied to the maximum permitted diversion amount. This results in sizing the raw water transmission facilities for an ultimate peak flow rate of 236 MGD.

3.1.3 Life Cycle Analysis Flow Rates

The North Water Treatment Plant will be constructed with an ultimate capacity of 280 MGD. For the purposes of the life cycle cost analysis, the plant was assumed to be constructed in four 70 MGD phases (**Table 84**). Pumping rates were assumed to be 3% above these values to account for losses in the terminal storage reservoir and treatment processes.

North Texas Municipal Water District

Table 85 – North Water Treatment Plant Phasing

Year	Maximum (MGD)	Average (MGD)
2021	70	40
2026	140	80
2030	210	120
2035	280	165

Seasonal variations in flow were accounted for in the life cycle analysis. A 1.4 peaking factor was applied to the average annual flow for 4 months out of the year, and a 0.8 factor applied for the remaining 8 months. These values were based on the ratio of monthly average to annual average flows in the existing NTMWD system between 2007 and 2012.

In the first phase of the plant, the annual flow was assumed to be the same in year 1 as in year 5. For the subsequent expansions, the flow increases annually with the flow rate matching current plant capacity in the expansion year (i.e. expand from 140 MGD to 210 MGD in 2030 and hit peak flow of 140 MGD in 2030). Of the 280 MGD ultimate capacity, a future connection to the Texoma-Wylie raw water pipeline will supply 70-80 MGD of the needed raw water supply for the plant. This future connection to the Texoma-Wylie raw water line is discussed further in the Technical Memorandum titled “NTWP Terminal Storage Reservoir Analysis”.

3.2 DESIGN ASSUMPTIONS

Friction losses through the pipeline were calculated using the Hazen-Williams equation with a long-term roughness coefficient (C-value) of 120. This C-value is typical for aged raw water pipelines. It is assumed that all maintenance required to maintain this value will be conducted by the NTMWD, including cleaning the pipeline as necessary. Velocity in the pipe was limited to 9 feet per second under all flows to limit surge potential and maintain headloss in an acceptable range.

A 420 million gallon Terminal Storage Reservoir (TSR) will be constructed north of the proposed treatment plant site. Several locations were considered with a final recommendation made for a site west of Leonard, off of CR 4965. This site will have a normal water surface elevation of 731 and a minimum elevation of 714. The water surface elevation for the treatment plant headworks was assumed to be 711. Evaluation of the hydraulics from the TSR to the WTP determined that dual 102”



North Texas Municipal Water District

pipes are required for the peak flow of 236 MGD. Further information regarding the TSR, site selection, and pipe sizing can be found in the “NWTP Terminal Storage Reservoir Analysis” technical memorandum that was submitted on the same day as this report.

3.3 PIPE DIAMETER OPTIMIZATION

The required pipe diameter was determined using a life cycle cost analysis. As pipe diameter decreases, the capital cost to construct the line also decreases. However, the power required to push a given flow through a smaller pipe is greater due to increased friction losses within the pipe. The purpose of the life cycle cost analysis was to balance the capital and power costs to determine an optimum pipe diameter. The flows used in the analysis are shown above in **Table 85**, and the other variables used are included in **Table 86**.

Table 86 – Life Cycle Analysis Variables

Variable	Value
Analysis Duration	50 years
Bond Interest Rate	4.5%
Bond Term	25 Years
Inflation Rate	3%
Discount Rate	5%
Electricity Rate (2013)	5.5¢/kW-hr

The total annual cost was determined for each year of the analysis period and included debt service and inflated power cost. These future values were returned to present values and summed to determine the total present worth. This analysis was performed for 78- through 108-inch pipe and can be found in **Appendix B**. A summary of the results are shown in **Figure 28** and **Table 87**.

North Texas Municipal Water District

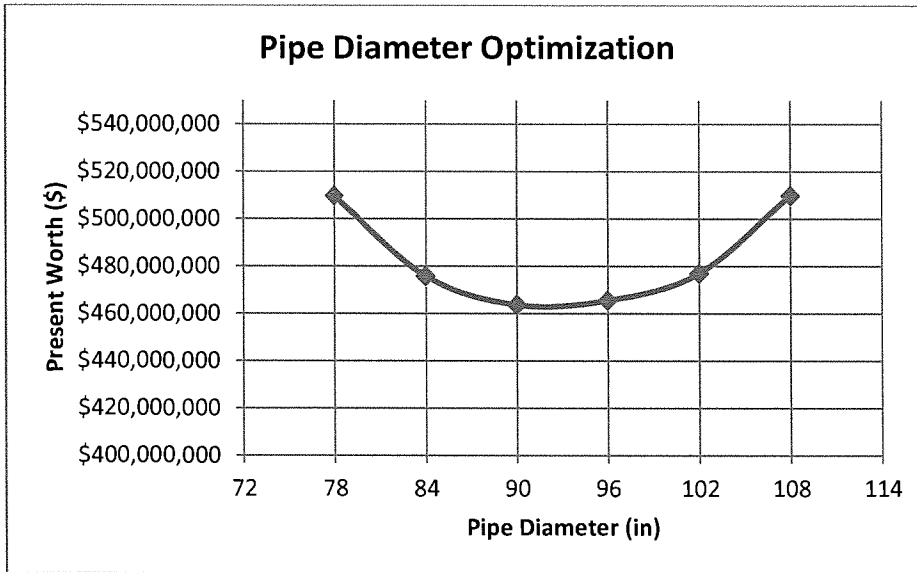

Figure 28 – Pipe Diameter Optimization

Table 87 – Pipe Diameter Present Worth Comparison

Diameter (in)	Total Present Worth (50 yr LCCA)
78	\$509,616,901
84	\$475,802,222
90	\$463,620,281
96	\$465,470,732
102	\$476,890,428
108	\$509,799,096

Both the 78-inch and 84-inch lines were inadequate since the velocity in the pipe (9.44 fps) at the ultimate peak flow of 236 MGD was beyond the 9 feet per second limit, and were removed from consideration. Also, a 78 or 84-inch line would cause the pressure near the pump station to exceed 300 psi, which is not desirable by the NTMWD. Hydraulic grade lines were developed for both 90-inch and 96-inch pipelines (**Figure 29** and **Figure 30**, respectively). Both the 90-inch and 96-inch lines have velocities and pressures at acceptable levels during normal flows. The 90-inch line causes peak flow pressure to exceed 250 psi near the pump station, but was determined to have the lowest present worth (as seen in **Table 87**). Pressures exceeding 250 psi can be significant because it requires special

North Texas Municipal Water District

valve castings and pushes the pipeline pressure class up to 300 psi, which may be able to be reduced somewhat during final design. The 102 and 108-inch lines were determined to require high capital cost for limited energy savings.

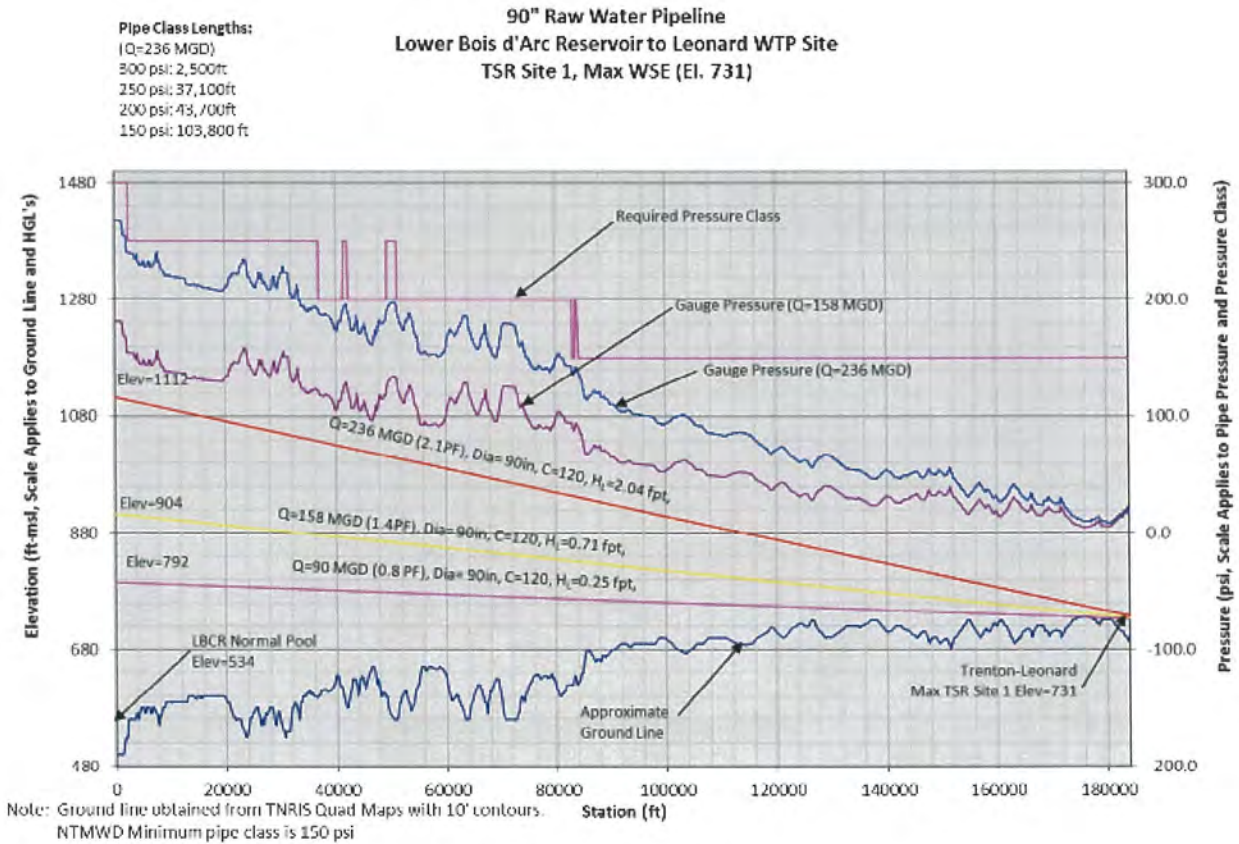

Figure 29 – 90-inch Pipeline HGL

North Texas Municipal Water District

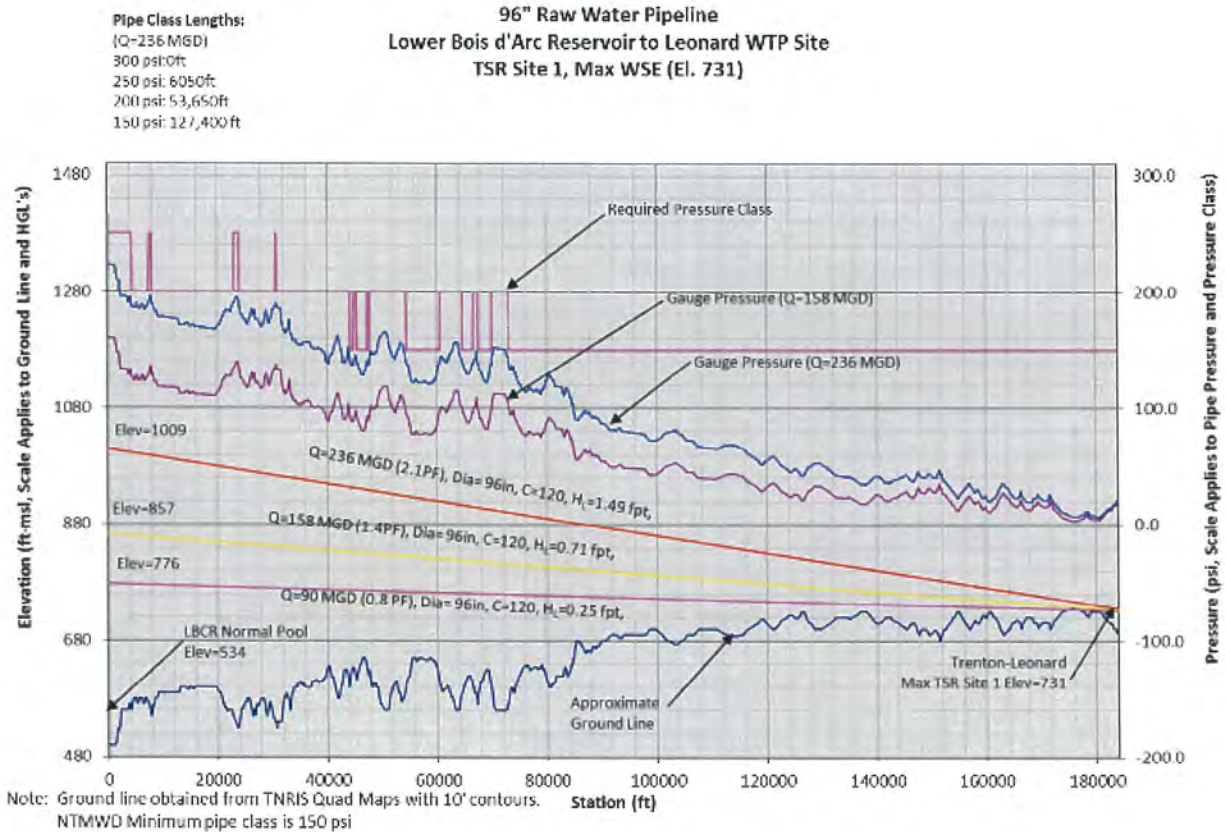
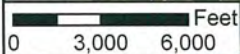
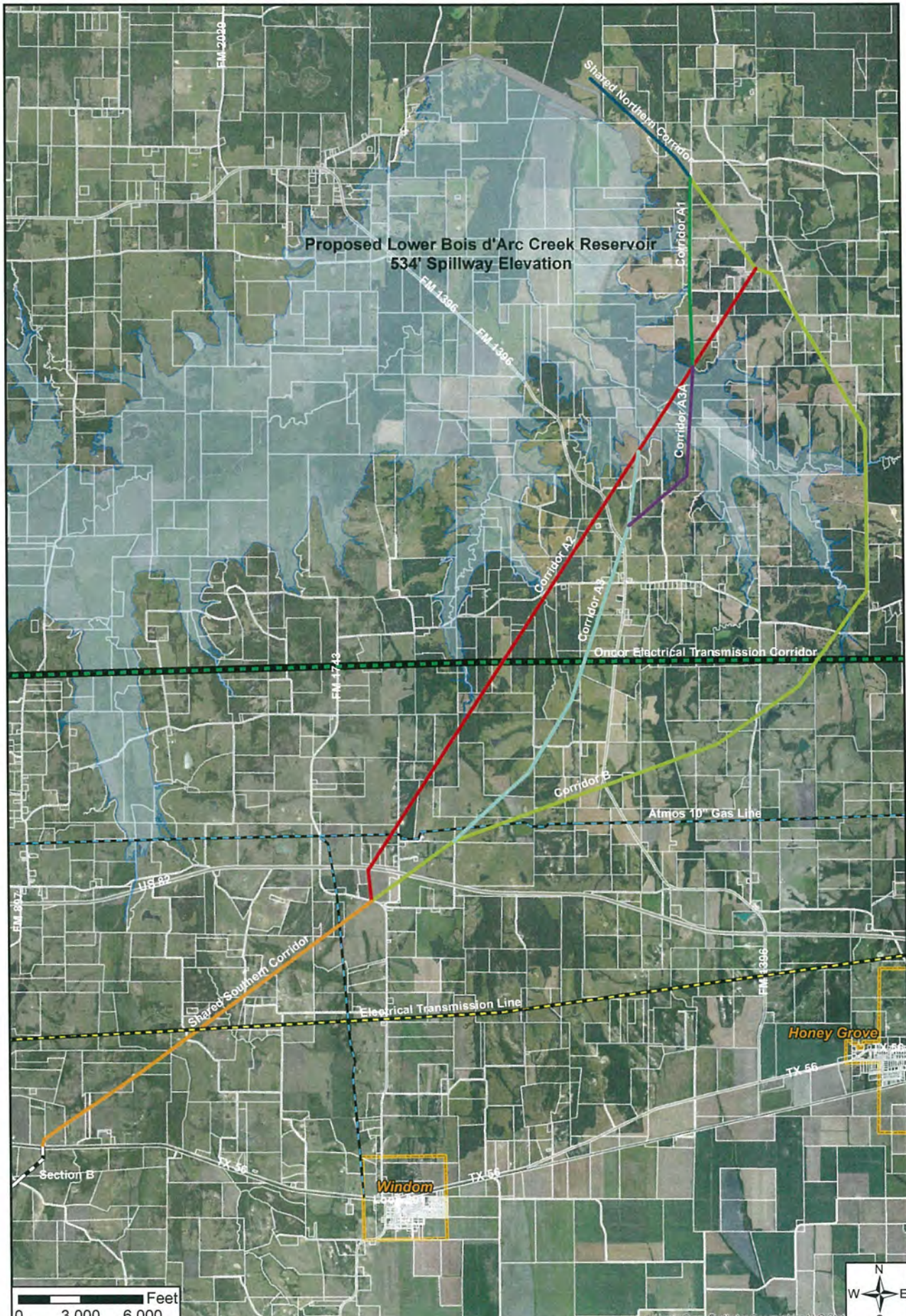

Figure 30 – 96-inch Pipeline HGL

Based on this analysis, the pipeline between LBCR and the TSR is recommended to be 90 inches in diameter. This size provides the lowest total present worth and effectively balances the capital and power costs through the life of the project. The additional capital cost necessary for constructing a 96 inch diameter pipeline is more significant than the increased cost of fabricating 90 inch 300 psi pressure class pipe and valves.



APPENDIX A
DESIGN REPORT FIGURES



PROJECT NO:	NTD1316
DATE CREATED:	Date: 10/24/13
BATHY & COORDINATE SYSTEM:	NAD83 State Plane North Texas North Central
FILE NAME:	LR_6_28_2013 Cost Estimate Section A.mxd
PREPARED BY:	VMS



NORTH TEXAS MUNICIPAL WATER DISTRICT
Lower Bois d'Arc Creek Reservoir Raw Water Pipeline

Section A Corridor

FREES & NICHOLS
 2711 NORTH HASKELL AVENUE
 SUITE 3300
 DALLAS, TEXAS 75204
 P: 214-217-2200
 F: 214-217-2201

Section
 A
 Exhibit
 1

ISS NO: NTD1316
 Location: \\P:\GIS_P\WORKING\02-LBR_Alignment_to_NWTP\Section A Exhibit\Cost Estimates\LR_6_28_2013 Cost Estimate Section A.mxd
 Updated: Thursday, October 24, 2013 1:36:31 PM

Option A2 Reservoir Crossing Profile

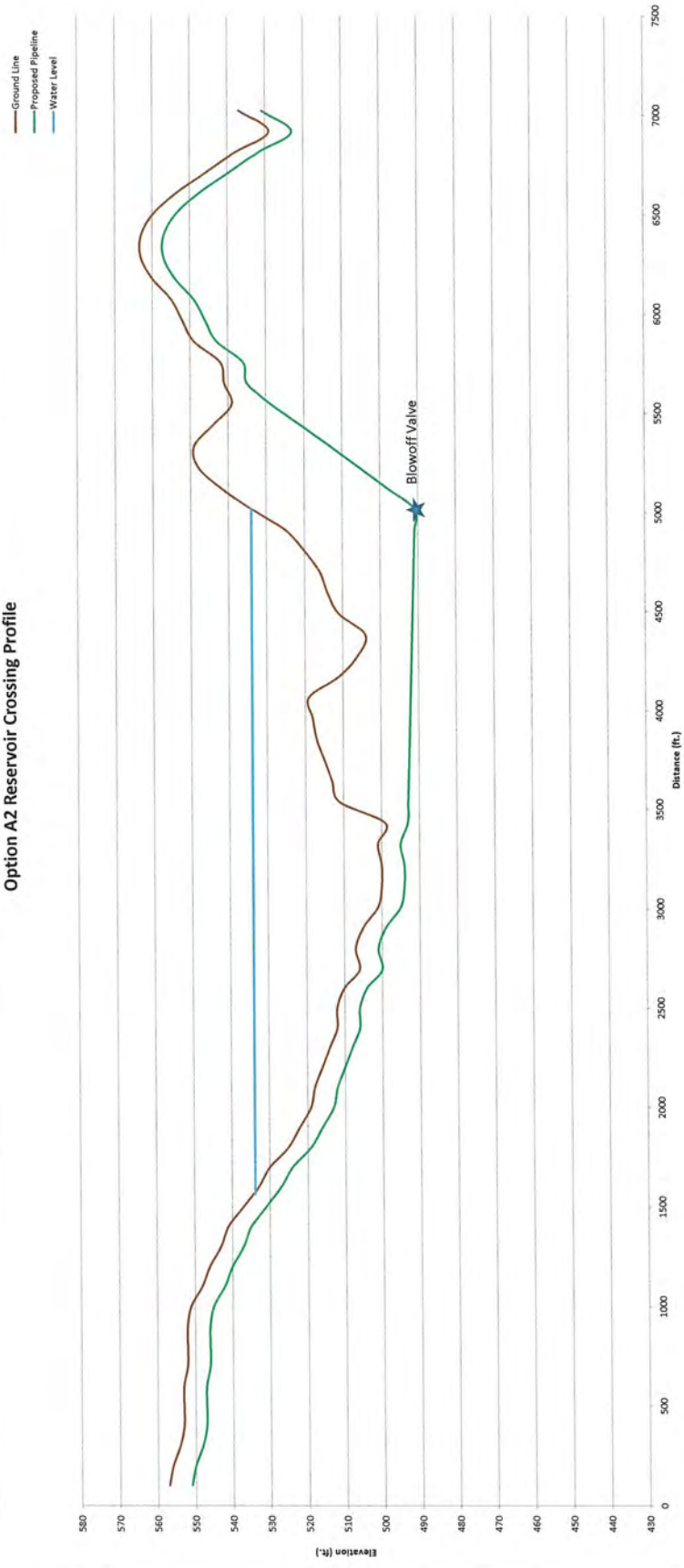

Option A3A Reservoir Crossing Profile

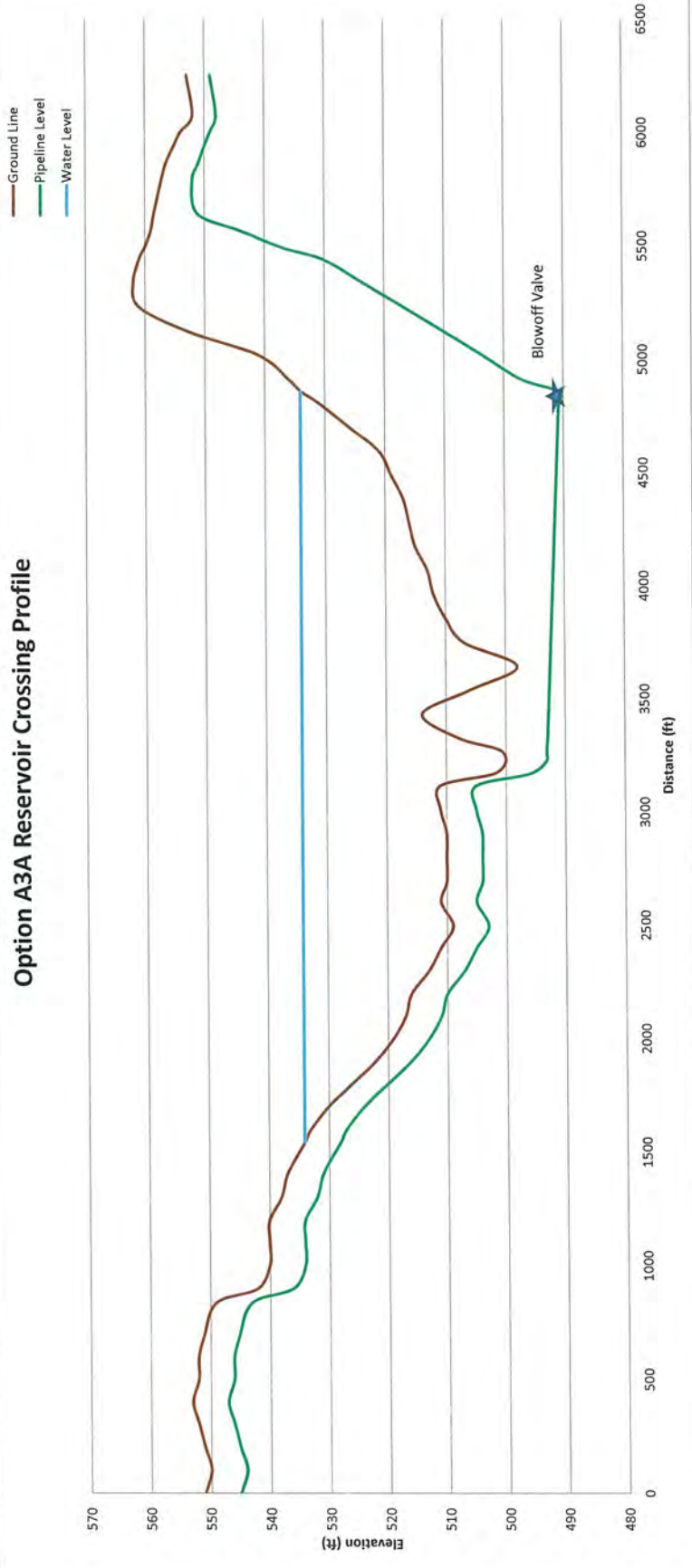

**PIPE BUOYANCY DESIGN PROCESS--FLOTATION OF PIPES
SIMPLIFIED, WORST CASE EXAMPLE**

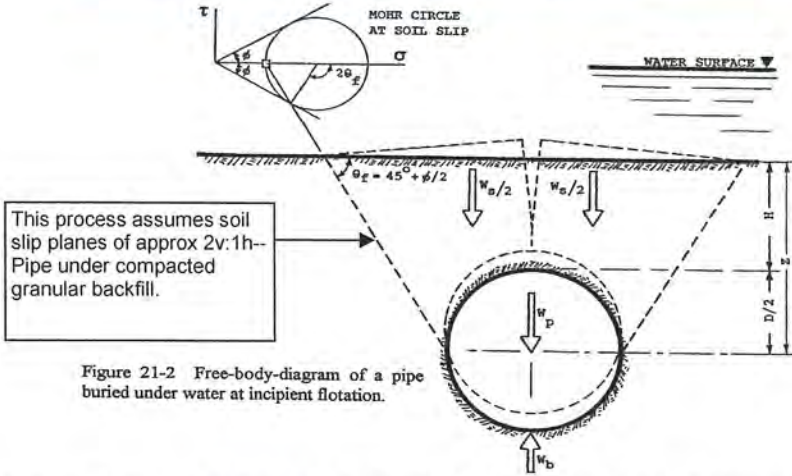

Reference: "Structural Mechanics of Buried Pipes" by Watkins & Anderson

VARIABLES: = user input = constant or calculated

- $W_p =$ 0.00 lb/lf (Weight of empty pipe per unit length)
 $W_c =$ 0.00 lb/lf (Weight of pipe contents per unit length, set to zero for worst case)
 $OD =$ 116.00 inches (outside pipe diameter) 9.67 feet
 $ID =$ 114.00 inches (inside pipe diameter) 9.50 feet
 $\gamma_w =$ 62.40 lb/ft³ (unit weight of water, or other liquid pipe is immersed in)

CALCULATED VALUES:

$W = W_c + W_p =$ 0.00 lb/lf (Weight of Pipe & Contents)

$\gamma_b =$ 62.40 lb/ft³ (buoyant unit weight of soil)--see embedded comment

$D =$ 115.00 inches (mean diameter) 9.58 feet

$W_s =$ Buoyant weight of soil wedges above a buried pipe per (lb/lf)
 Assumes soil slip planes of approximately 2v:1h

$$W_s = \gamma_b [Z(D + 0.5Z) - \pi D^2 / 8]$$
See below for values

$W_b =$ Buoyant (uplift force) on pipe (lb/lf) = weight of liquid displaced

$$W_b = \pi(OD)^2 \gamma_w / 4$$
4577.28 lb/ft

$fs =$
$$fs = \frac{ABS(W_T)}{W_b}$$
safety factor (see below for values)

H (ft)	Z (ft)	fs	W_s (lb/ft)	W (lb/ft)	W_T (lb/ft)	W_b (lb/ft)
1	5.79	0.49	-2260.62	0.00	-2260.62	4577.28
2	6.79	0.71	-3251.22	0.00	-3251.22	4577.28
3	7.79	0.94	-4304.22	0.00	-4304.22	4577.28
4	8.79	1.18	-5419.62	0.00	-5419.62	4577.28
5	9.79	1.44	-6597.42	0.00	-6597.42	4577.28
6	10.79	1.71	-7837.62	0.00	-7837.62	4577.28
7	11.79	2.00	-9140.22	0.00	-9140.22	4577.28
8	12.79	2.30	-10505.2	0.00	-10505.22	4577.28
9	13.79	2.61	-11932.6	0.00	-11932.62	4577.28
10	14.79	2.93	-13422.4	0.00	-13422.42	4577.28
11	15.79	3.27	-14974.6	0.00	-14974.62	4577.28
12	16.79	3.62	-16589.2	0.00	-16589.22	4577.28
13	17.79	3.99	-18266.2	0.00	-18266.22	4577.28
14	18.79	4.37	-20005.6	0.00	-20005.62	4577.28
15	19.79	4.76	-21807.4	0.00	-21807.42	4577.28
16	20.79	5.17	-23671.6	0.00	-23671.62	4577.28
17	21.79	5.59	-25598.2	0.00	-25598.22	4577.28
18	22.79	6.03	-27587.2	0.00	-27587.22	4577.28
19	23.79	6.48	-29638.6	0.00	-29638.62	4577.28
20	24.79	6.94	-31752.4	0.00	-31752.42	4577.28
H >= 0.5D		fs >= 1.47222				
H < 0.5D		fs < 1.47222				

According to Watkins & Anderson, the height of cover should be at least half the pipe diameter. This correlates to a factor of safety of approximately 1.47222. This only applies when you have granular embedment or better compacted to at least 90% density. Also, if the designer has specified all welded joints, this added resistance is sufficient to resist uplift with only half the diameter of cover.

If the designer is unsure of the control of backfill or the embedment material is something other than granular, then a conservative rule of thumb would be to specify soil cover equal to pipe diameter.



PROJECT NO.	N7013138
DATE CREATED	Date: 11/05/20
BATHY & COORDINATE SYSTEM	NAD83 State Plane (ftal, Texas North Central)
FILE NAME	LBCR Corridor Alignment-APP.rvt
PREPARED BY	WPT

NORTH TEXAS MUNICIPAL WATER DISTRICT
Lower Bois d'Arc Creek Reservoir Raw Water Pipeline
Section A Corridor

FREESE NICHOLS
 2711 NORTH HASKELL AVENUE
 SUITE 3300
 DALLAS, TEXAS 75204
 P: 214-217-2200
 F: 214-217-2201

Section
 A
 Exhibit
 5

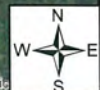
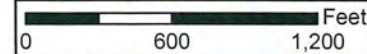
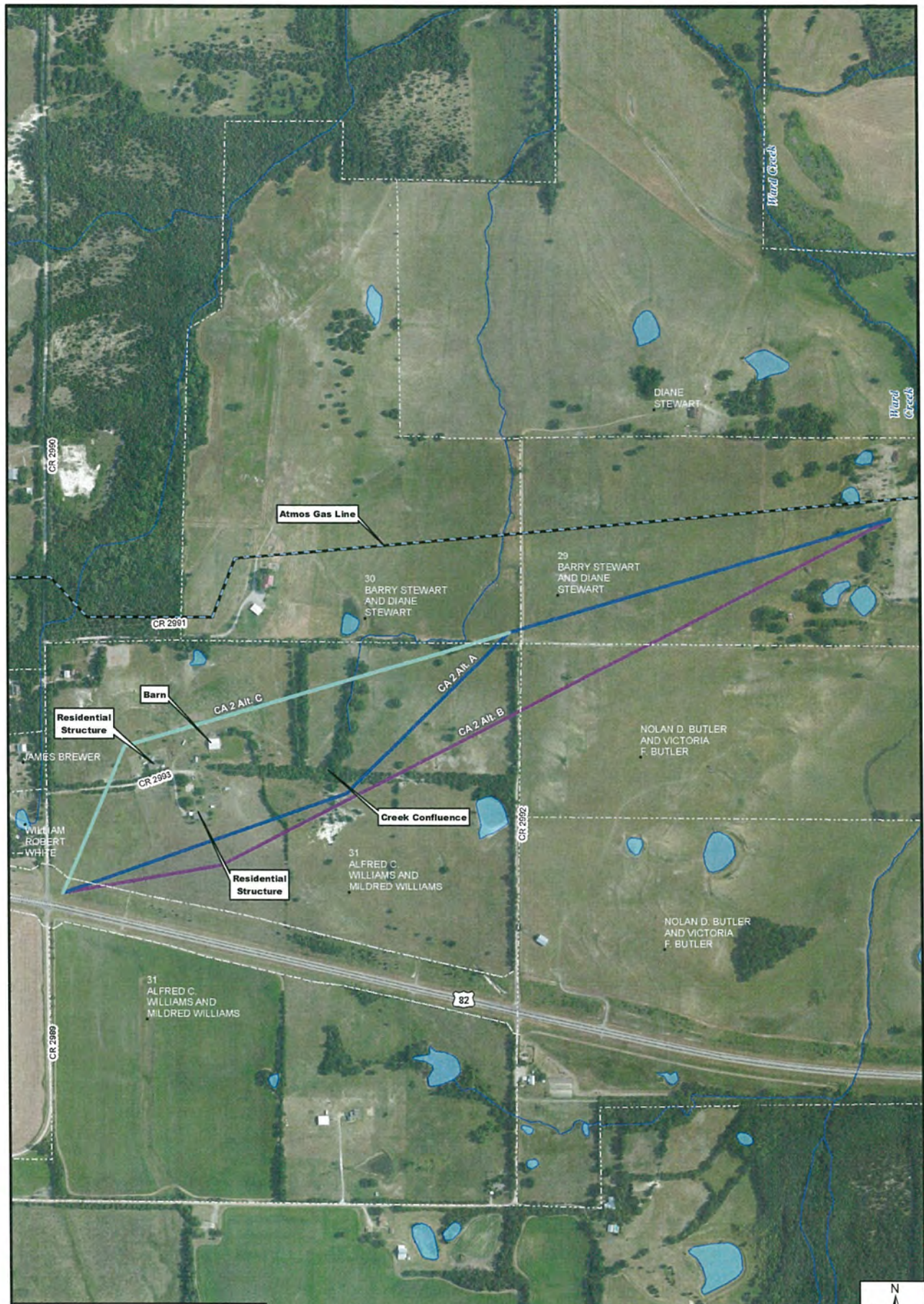

PROJECT NO.	N7013136
DATE CREATED	11/22/2011
DATUM & COORDINATE SYSTEM	NAD83 State Plane (North Texas North Central)
FILE NAME	CAD APPR.dwg
PREPARED BY	VMS



NORTH TEXAS MUNICIPAL WATER DISTRICT
Lower Bois d'Arc Creek Reservoir Raw Water Pipeline

Section A Corridor - Conflict Area #2

FREESE NICHOLS
 2711 NORTH HASKELL AVENUE
 SUITE 3300
 DALLAS, TEXAS 75204
 P: 214-217-2200
 F: 214-217-2201

Section
 A
 Exhibit
 6

Image courtesy of USGS State of TX

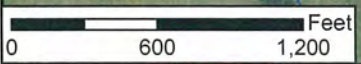

PN PROJECT NO	HTD13136
DATE CREATED	DATE 11/05/2011
DATUM & COORDINATE SYSTEM	NAD83 State Plane (feet) Texas North Central
FILE NAME	CA3-APP.dwg
PREPARED BY	WPI



NORTH TEXAS MUNICIPAL WATER DISTRICT
Lower Bois d'Arc Creek Reservoir Raw Water Pipeline
Section A Corridor - Conflict Area #3

FREESE NICHOLS
 2711 NORTH HASKELL AVENUE
 SUITE 3300
 DALLAS, TEXAS 75204
 P: 214-217-2200
 F: 214-217-2201

Section
 A
 Exhibit
 7

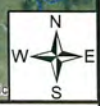
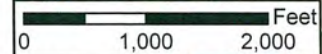
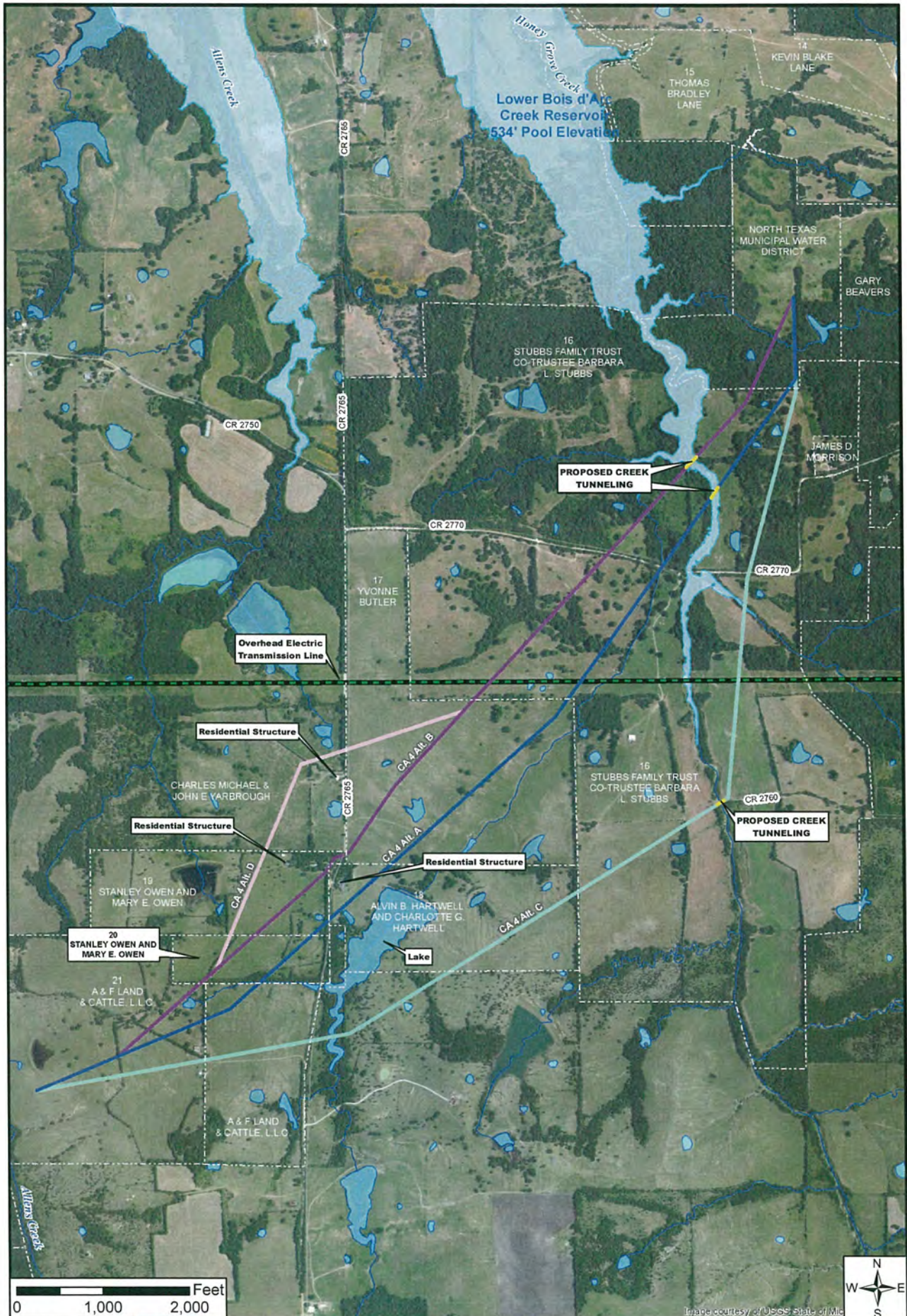

PROJECT NO.	NTD138
DATE CREATED	DATE: 11/20/21
DATUM & COORDINATE SYSTEM	NAD83 State Plane (feet), Texas North Central
FILE NAME	CA#4APP.mxd
PREPARED BY	URS



NORTH TEXAS MUNICIPAL WATER DISTRICT
Lower Bois d'Arc Creek Reservoir Raw Water Pipeline
Section A Corridor - Conflict Area #4

FREESE NICHOLS
 2711 NORTH HASKELL AVENUE
 SUITE 3300
 DALLAS, TEXAS 75204
 P: 214-217-2200
 F: 214-217-2201

Section
 A
 Exhibit
 8

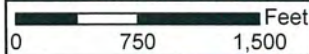

PROJECT NO.	NTD13154
DATE CREATED	Date: 11/02/2011
DATUM & COORDINATE SYSTEM	NAD83 State Plane (feet) Texas North Central
FILE NAME	CAD-APP.dwg
PREPARED BY	WPC



NORTH TEXAS MUNICIPAL WATER DISTRICT
Lower Bois d'Arc Creek Reservoir Raw Water Pipeline

Section A Corridor - Conflict Area #5

FREESE NICHOLS
 2711 NORTH HASKELL AVENUE
 SUITE 3300
 DALLAS, TEXAS 75204
 P: 214-217-2200
 F: 214-217-2201

Section
 A
 Exhibit
 9

-Image courtesy of USGS State of MS

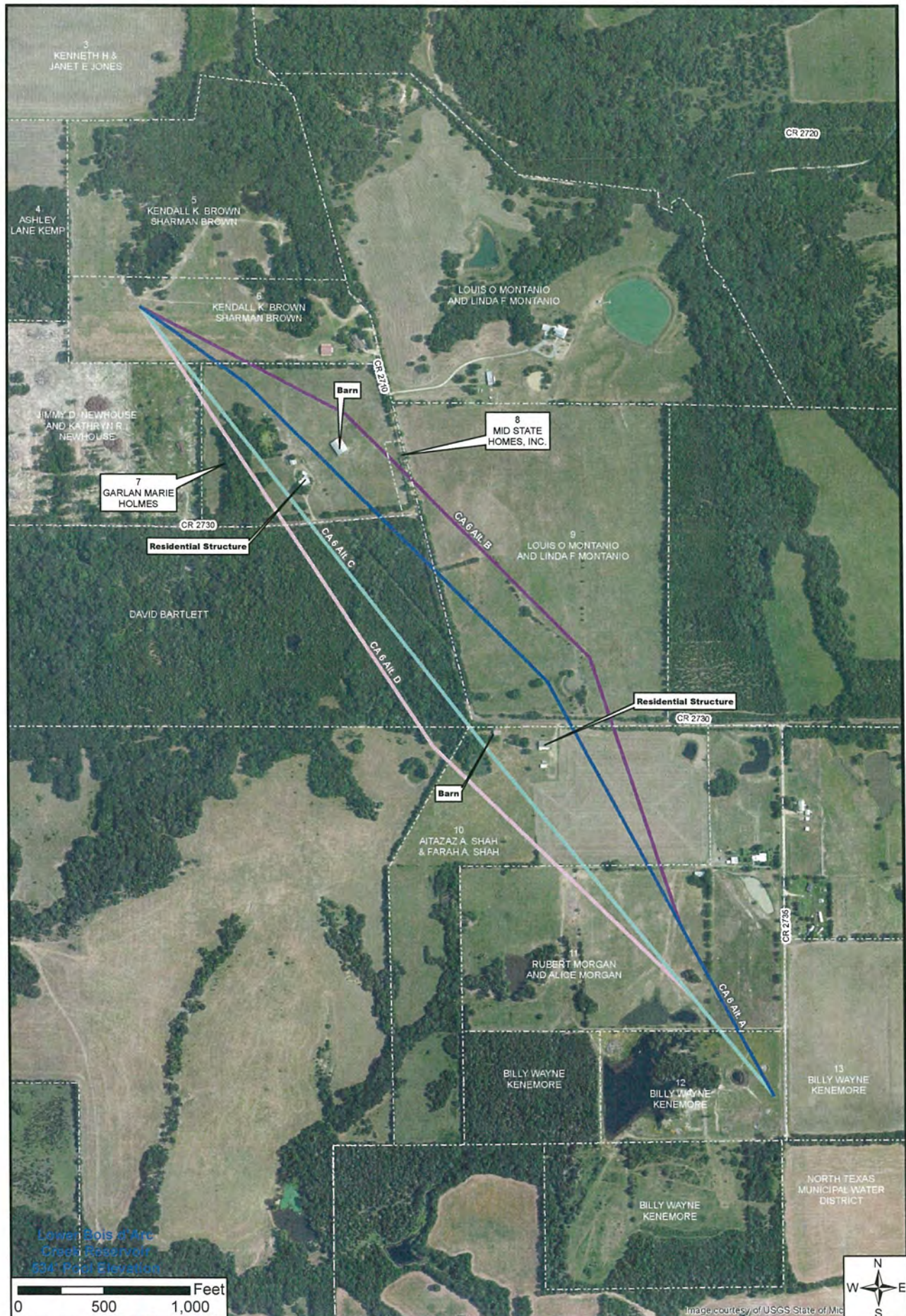

Lower Bois d'Arc
Creek Reservoir
534' Pool Elevation

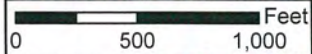

PROJECT NO	NT013138
DATE CREATED	Date: 11/22/2017
DRAW & COORDINATE SYSTEM	NAD83 State Plane (North Texas North Central)
FILE NAME	CARAPP.mxd
PREPARED BY	WRS



NORTH TEXAS MUNICIPAL WATER DISTRICT
Lower Bois d'Arc Creek Reservoir Raw Water Pipeline
Section A Corridor - Conflict Area #6

FREESE NICHOLS
 2711 NORTH HASKELL AVENUE
 SUITE 3300
 DALLAS, TEXAS 75204
 P: 214-217-2200
 F: 214-217-2201

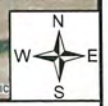

Section
A
 Exhibit
10

Image courtesy of USGS State of Mic



PROJECT NO	NTD-1336
DATE CREATED	Date: 11/05/2013
DATUM & COORDINATE SYSTEM	NAD83 State Plane (feet) Texas North Central
FILE NAME	Attachment 1 - Corridor Map1.mxd
PREPARED BY	WRS



NORTH TEXAS MUNICIPAL WATER DISTRICT
Lower Bois d'Arc Creek Reservoir Raw Water Pipeline

Section A Corridor

FRESE NICHOLS
 2711 NORTH HASKELL AVENUE
 SUITE 3300
 DALLAS, TEXAS 75204
 P: 214-217-2200
 F: 214-217-2201

Section
 A
 Exhibit
 11

Copyright 2013 by Freese Nichols, Inc. All rights reserved. Freese Nichols, Inc. is a registered provider of professional engineering services in the State of Texas. License No. 10000. Freese Nichols, Inc. is a registered provider of professional land surveying services in the State of Texas. License No. 10000. Freese Nichols, Inc. is a registered provider of professional architectural services in the State of Texas. License No. 10000.

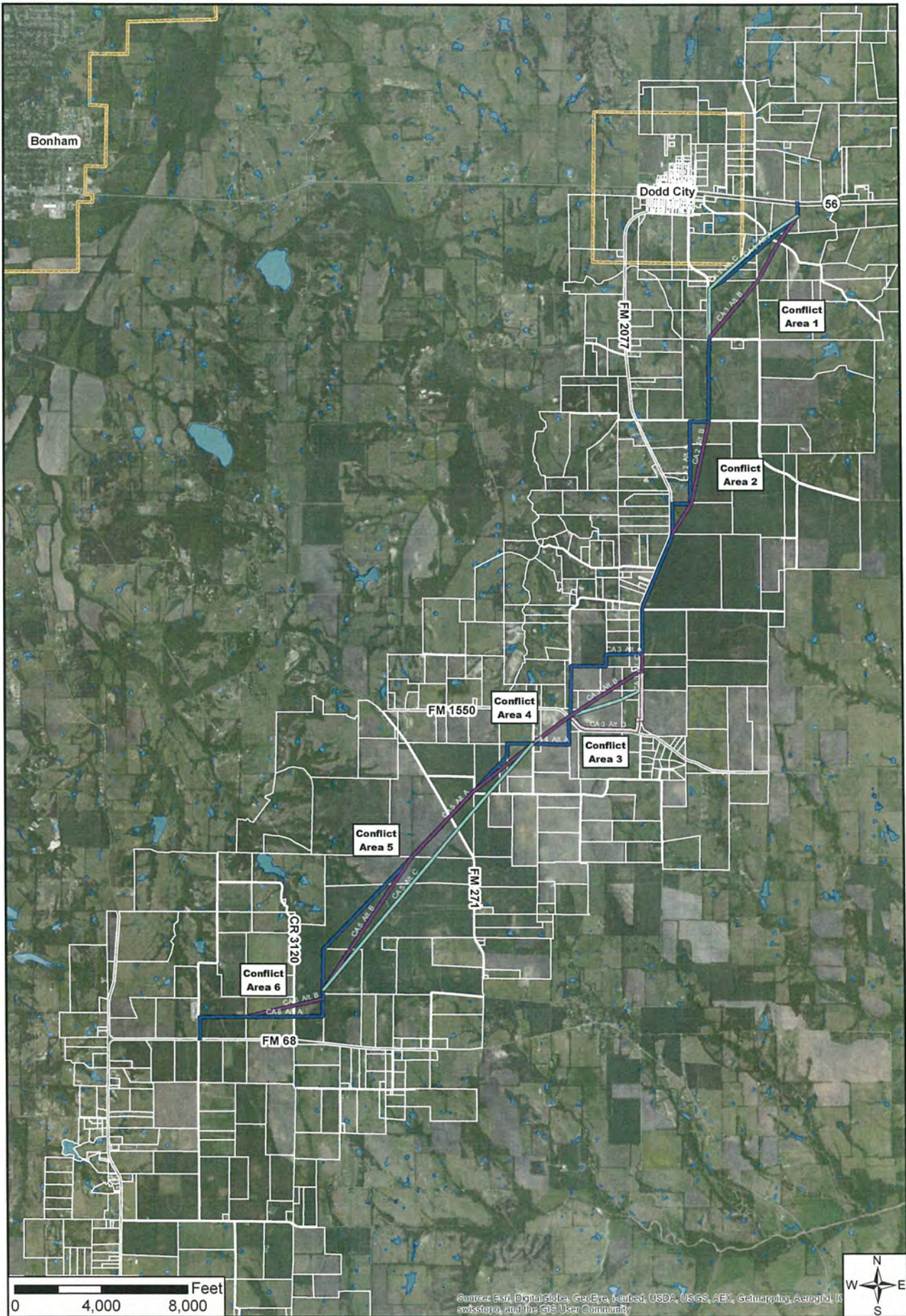

PROJECT NO: NTD13108
 DATE CREATED: 04/10/2013
 PROJECT COORDINATOR: ST/STB
 CAD/3D Data: Ryan (West Texas North Central)
 FILE NAME: SectionB_overall.mxd
 PREPARED BY: RP



NORTH TEXAS MUNICIPAL WATER DISTRICT
Lower Bois d'Arc Creek Reservoir Raw Water Pipeline
Section B Corridor

FREES NICHOLS
 10497 TOWN AND COUNTRY WAY
 SUITE 600
 HOUSTON, TEXAS 77024
 P: 713-600-6800
 F: 713-600-6801

Section
 B
 Exhibit
 1

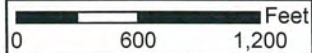
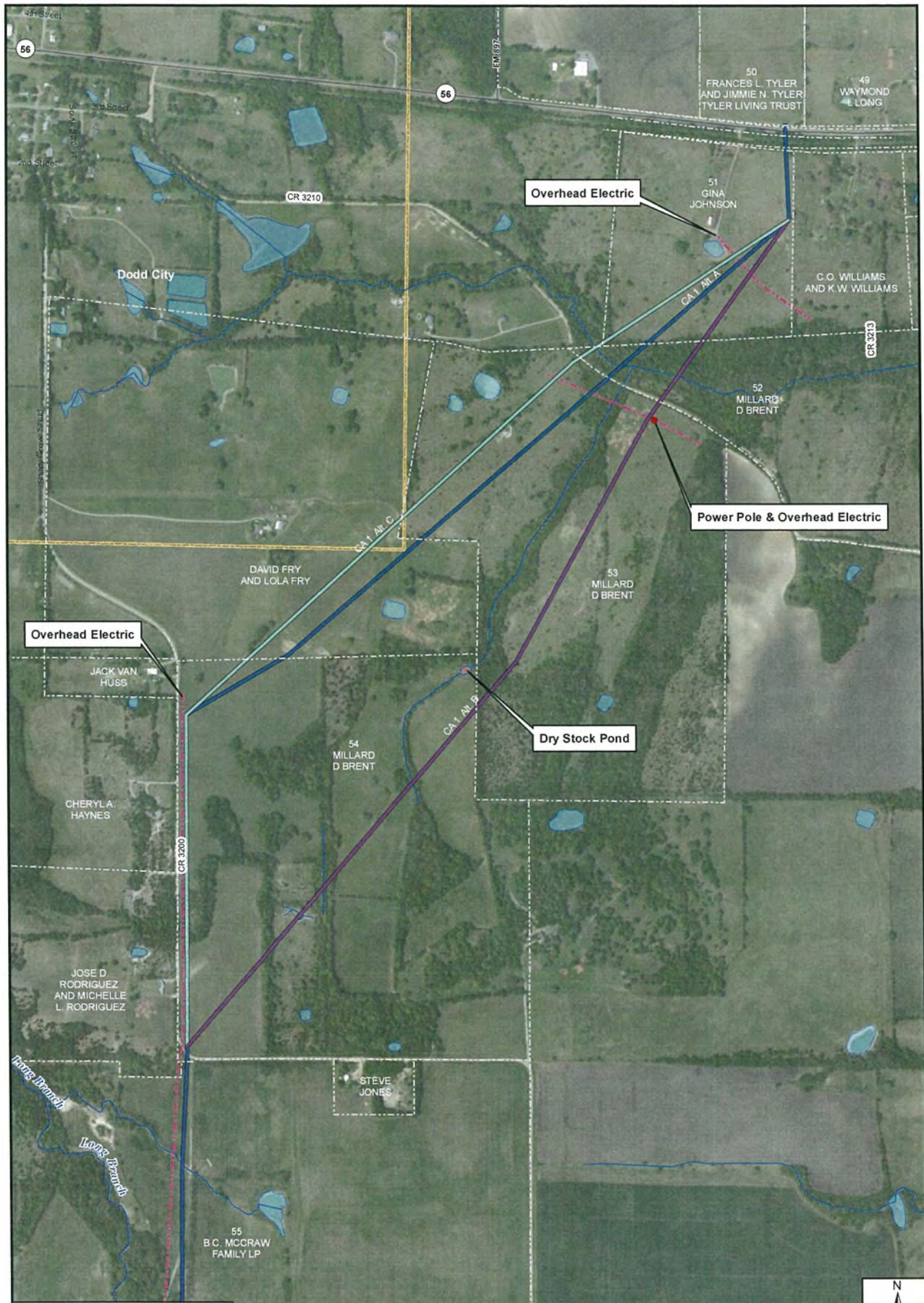

Source: Esri, DigitalGlobe, GeoEye, AeroVista, USDA, USGS, AeroGRID, IGN, Swayze, and the GIS User Community



PROJECT NO.	NTD1318
DATE CREATED	04/11/2013
DRAWN & CHECKED BY	SP/MS
UTM Zone	18Q UTM Zone 18Q
FILE NAME	SectionB_CA1.mxd
PREPARED BY	SP



NORTH TEXAS MUNICIPAL WATER DISTRICT
Lower Bois d'Arc Creek Reservoir Raw Water Pipeline
Section B Corridor - Conflict Area #1

FRESE NICHOLS
 10457 TOWN AND COUNTRY WAY
 SUITE 600
 HOUSTON, TEXAS 77024
 P: 713-600-6800
 F: 713-600-6801

Section
 B
 Exhibit
 2

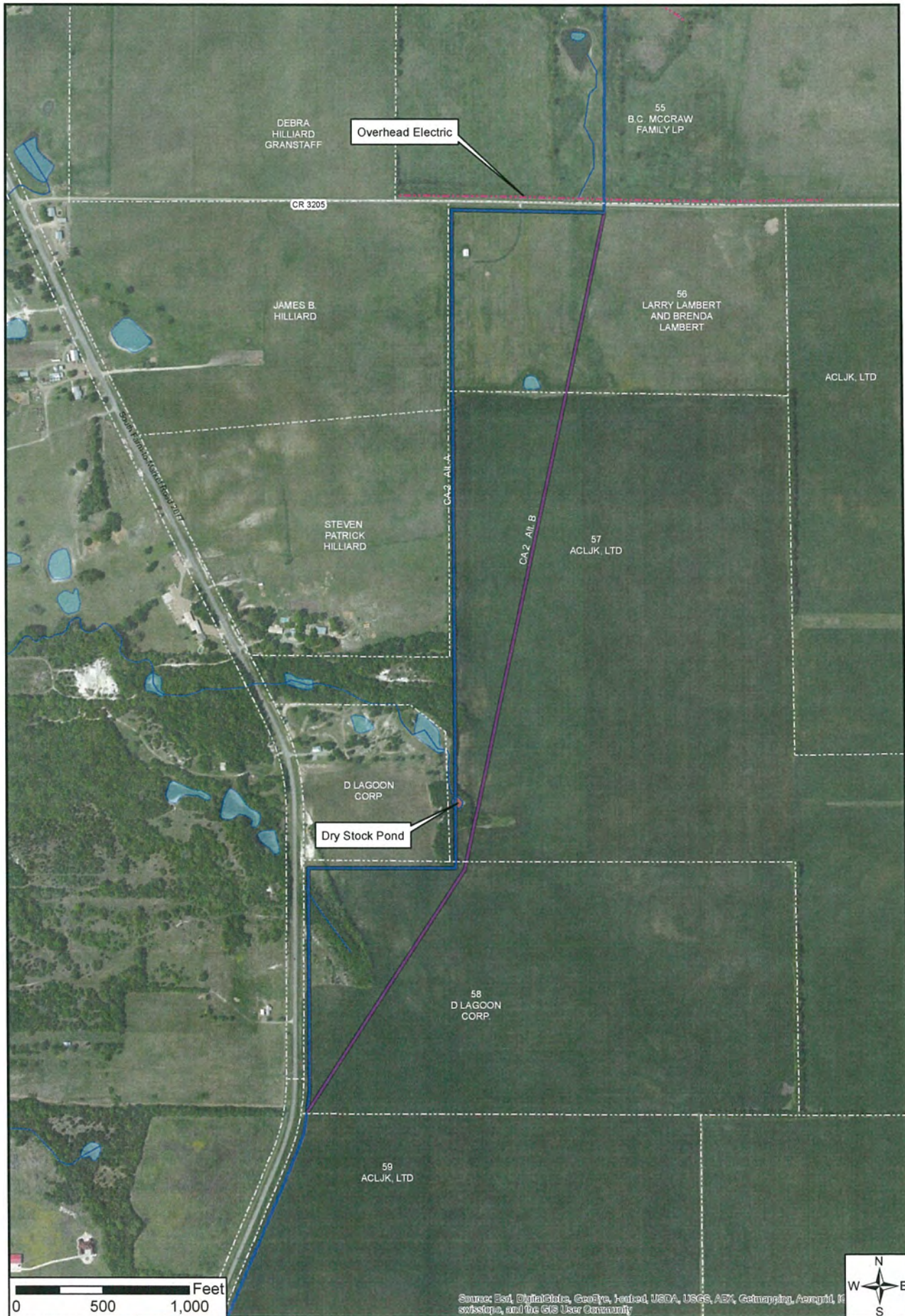

PROJECT NO: NT013136
 DATE CREATED: Date 11/09/2013
 PROJECT COORDINATOR: SP1850
 PADS (State Plane Area) Texas South Central
 FILE NAME: Section_B_CA2.mxd
 PREPARED BY: SP



NORTH TEXAS MUNICIPAL WATER DISTRICT
Lower Bois d'Arc Creek Reservoir Raw Water Pipeline
Section B Corridor - Conflict Area #2

FREES NICHOLS
 10497 TOWN AND COUNTRY WAY
 SUITE 600
 HOUSTON, TEXAS 77024
 P: 713-600-6300
 F: 713-600-6801

Section B
 Exhibit 3

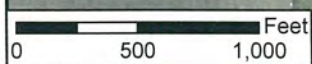
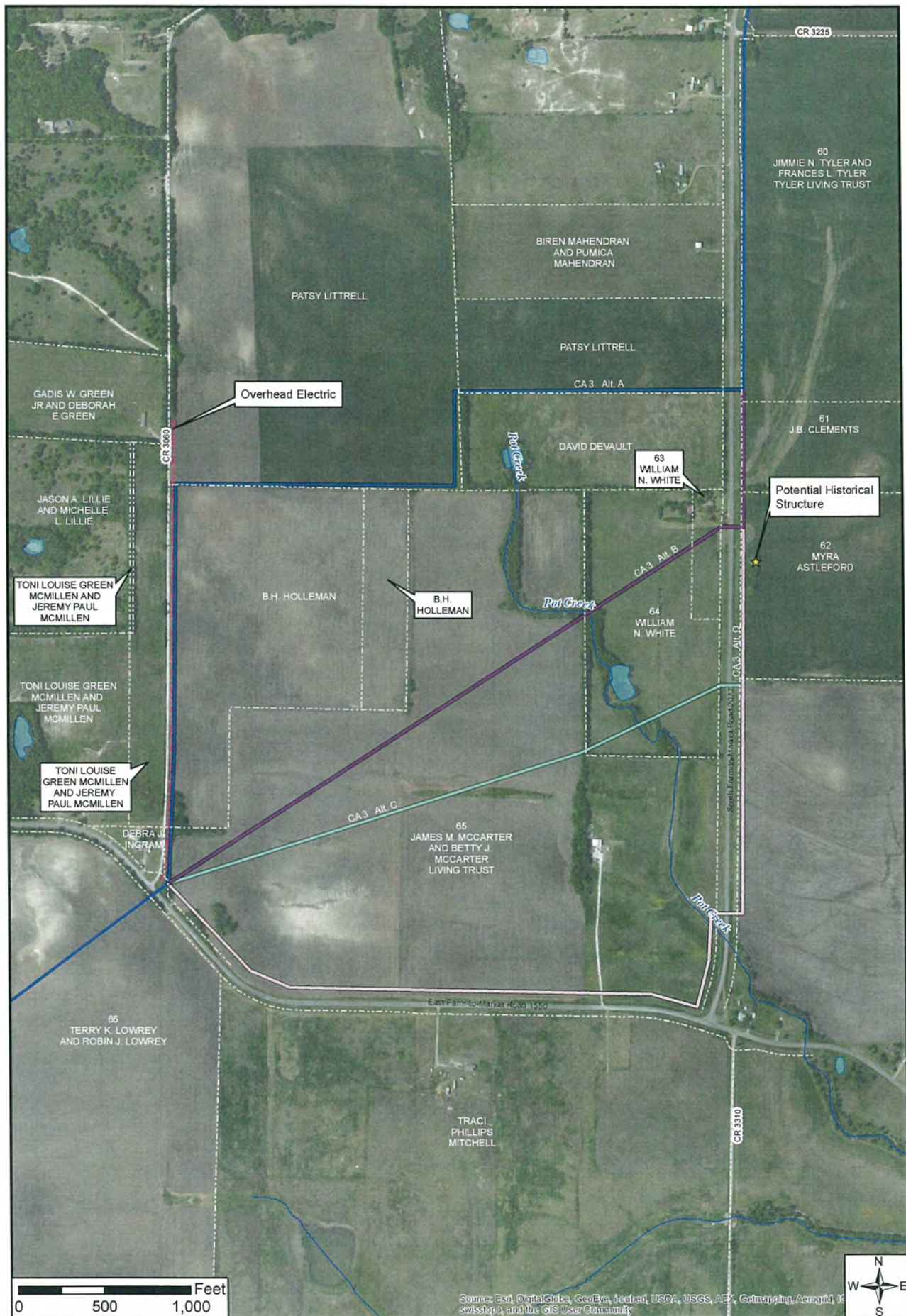

Source: Esri, DigitalGlobe, GeoEye, AeroGRID, USDA, USGS, AeroGRID, IGN, swisstopo, and the GIS User Community



PROJECT NO.	NTD13136
DATE CREATED	Date: 11/02/13
OWNER'S COORDINATE SYSTEM	NAD83 State Plane (feet) Texas North Central
FILENAME	SectionB_CA3.mxd
PREPARED BY	AP



NORTH TEXAS MUNICIPAL WATER DISTRICT
Lower Bois d'Arc Creek Reservoir Raw Water Pipeline
Section B Corridor - Conflict Area #3

FREESE NICHOLS
 10007 TOWN AND COUNTRY WAY
 SUITE 600
 HOUSTON, TEXAS 77024
 P: 713-600-6800
 F: 713-600-6801

Section
B
 Exhibit
4

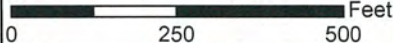

Source: Esri, DigitalGlobe, GeoEye, Earthstar (USA), USGS, AeroGRID, IGN, and the GIS User Community



PROJECT NO.	NTD13108
DATE CREATED	06/11/2013
PROJECT MANAGER	JP
FILE NAME	SectionB_CA4.mxd
PREPARED BY	JP



NORTH TEXAS MUNICIPAL WATER DISTRICT
Lower Bois d'Arc Creek Reservoir Raw Water Pipeline
Section B Corridor - Conflict Area #4

FREESE NICHOLS
 10497 TOWN AND COUNTRY WAY
 SUITE 805
 HOUSTON, TEXAS 77024
 P: 713-600-6800
 F: 713-600-6801

Section
 B
 Exhibit
 5

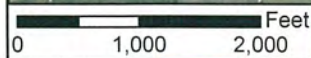
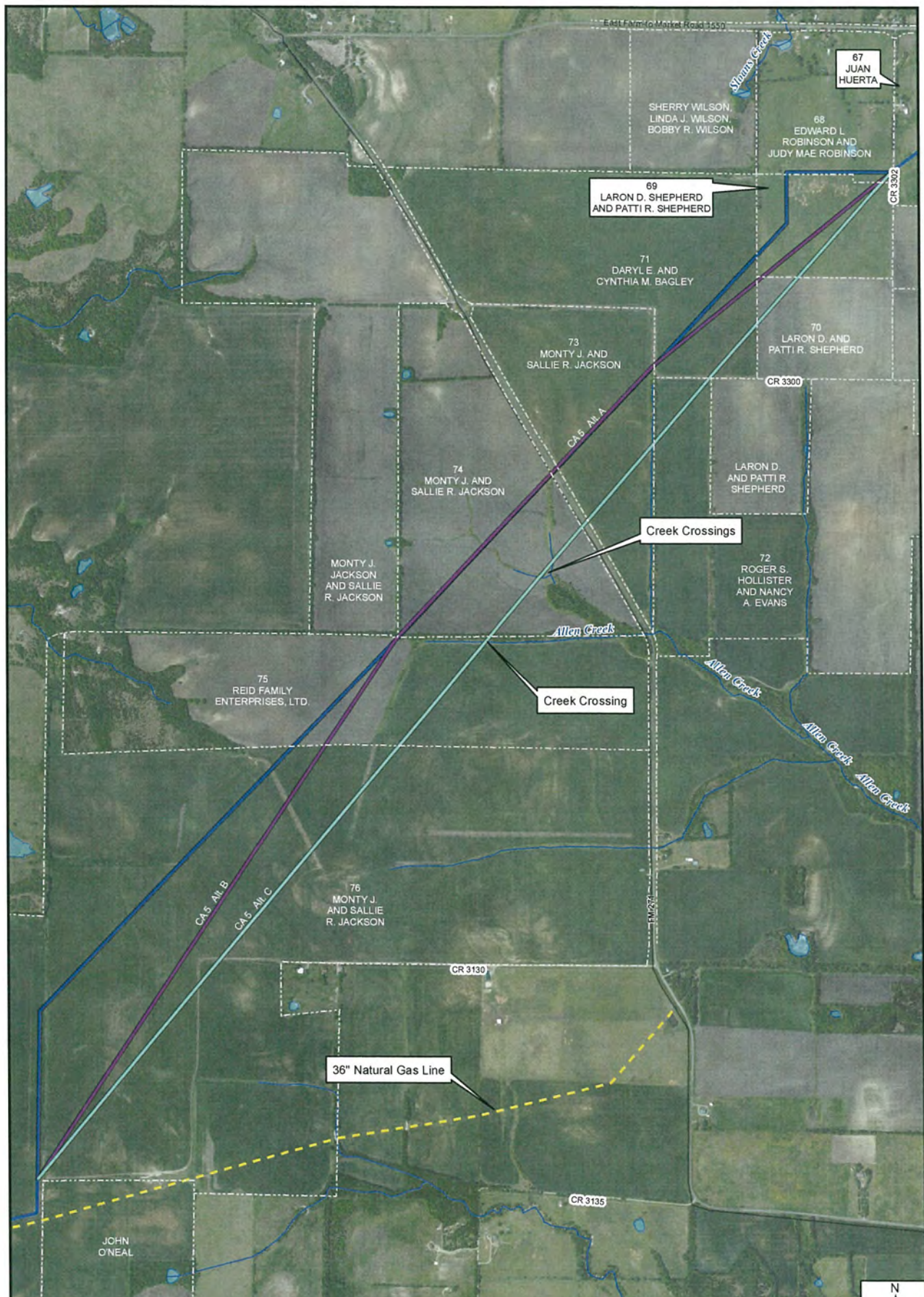

Source: Esri, DigitalGlobe, GeoEye, IGN, USDA, USGS, Aero, Getmapping, Aermap, IGN, swisstopo, and the GIS User Community

PROJECT NO: NTD13138
 DATE CREATED: 11/02/2013
 COORDINATE SYSTEM: NAD83
 STATE PLANE (FEET) TEXAS NORTH CENTRAL
 FILE NAME: SectionB_CAG.mxd
 PREPARED BY: RP



NORTH TEXAS MUNICIPAL WATER DISTRICT
Lower Bois d'Arc Creek Reservoir Raw Water Pipeline
Section B Corridor - Conflict Area #5

FREES NICHOLS
 10497 TOWN AND COUNTRY WAY
 SUITE 500
 HOUSTON, TEXAS 77024
 P: 713-600-6800
 F: 713-600-6801

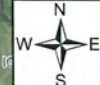

Section
 B
 Exhibit
 6

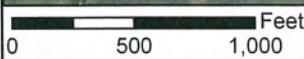
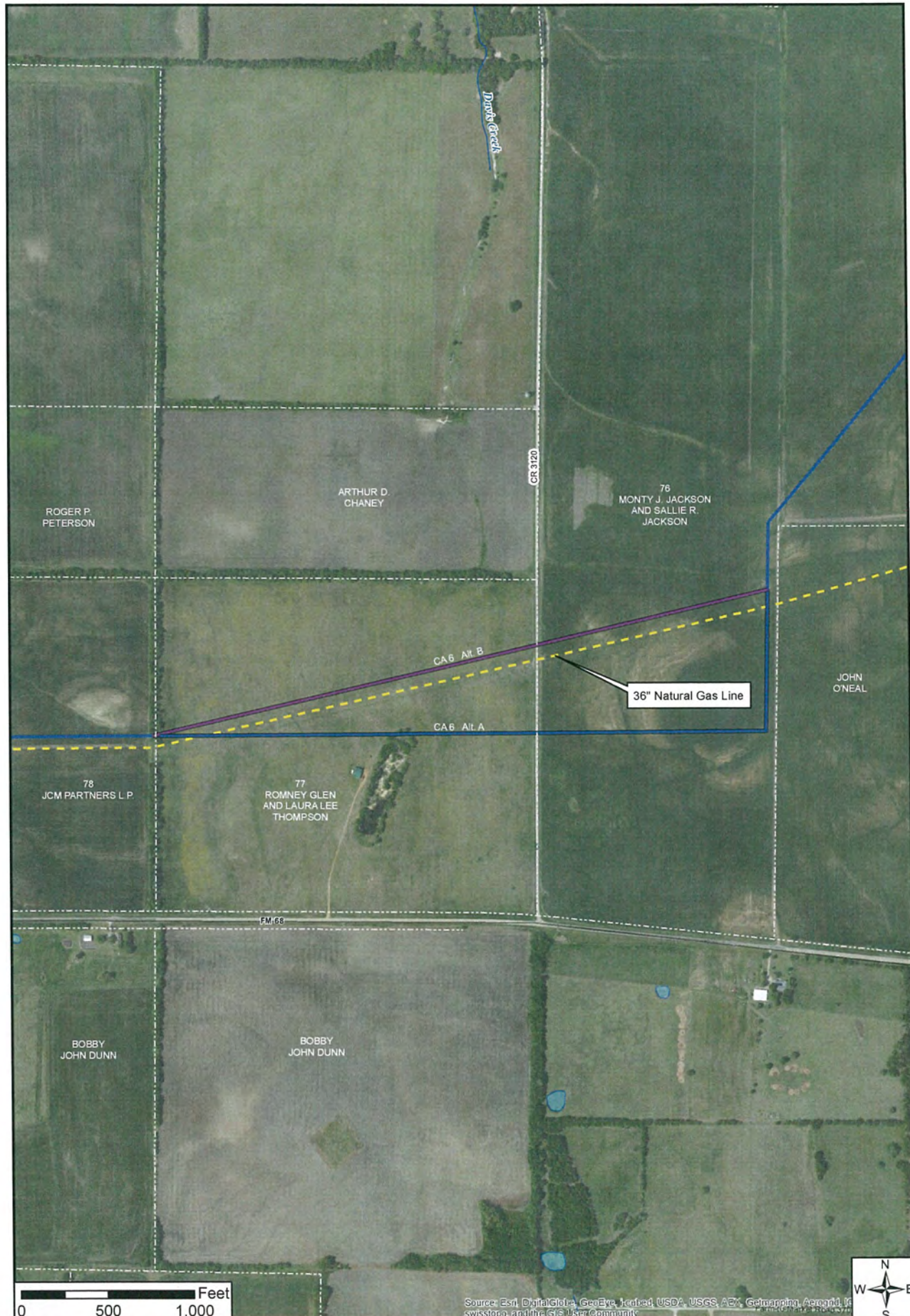

Source: Esri, DigitalGlobe, GeoEye, Earthstar (USA), USGS, AeroGRID, IGN, and the GIS User Community



PROJECT NO.	NTD13158
DATE CREATED	Date: 11/02/2013
CADFILE & COORDINATE SYSTEM	ARC/INFO State Plane (Peak) Texas North Central
FILE NAME	SectionB_CA6.mxd
PREPARED BY	MP



NORTH TEXAS MUNICIPAL WATER DISTRICT
Lower Bois d'Arc Creek Reservoir Raw Water Pipeline
Section B Corridor - Conflict Area #6

FREESE NICHOLS
 10497 TOWN AND COUNTRY WAY
 SUITE 600
 HOUSTON, TEXAS 77024
 P: 713-600-6800
 F: 713-600-6801

Section
 B
 Exhibit
 7

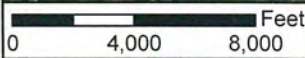
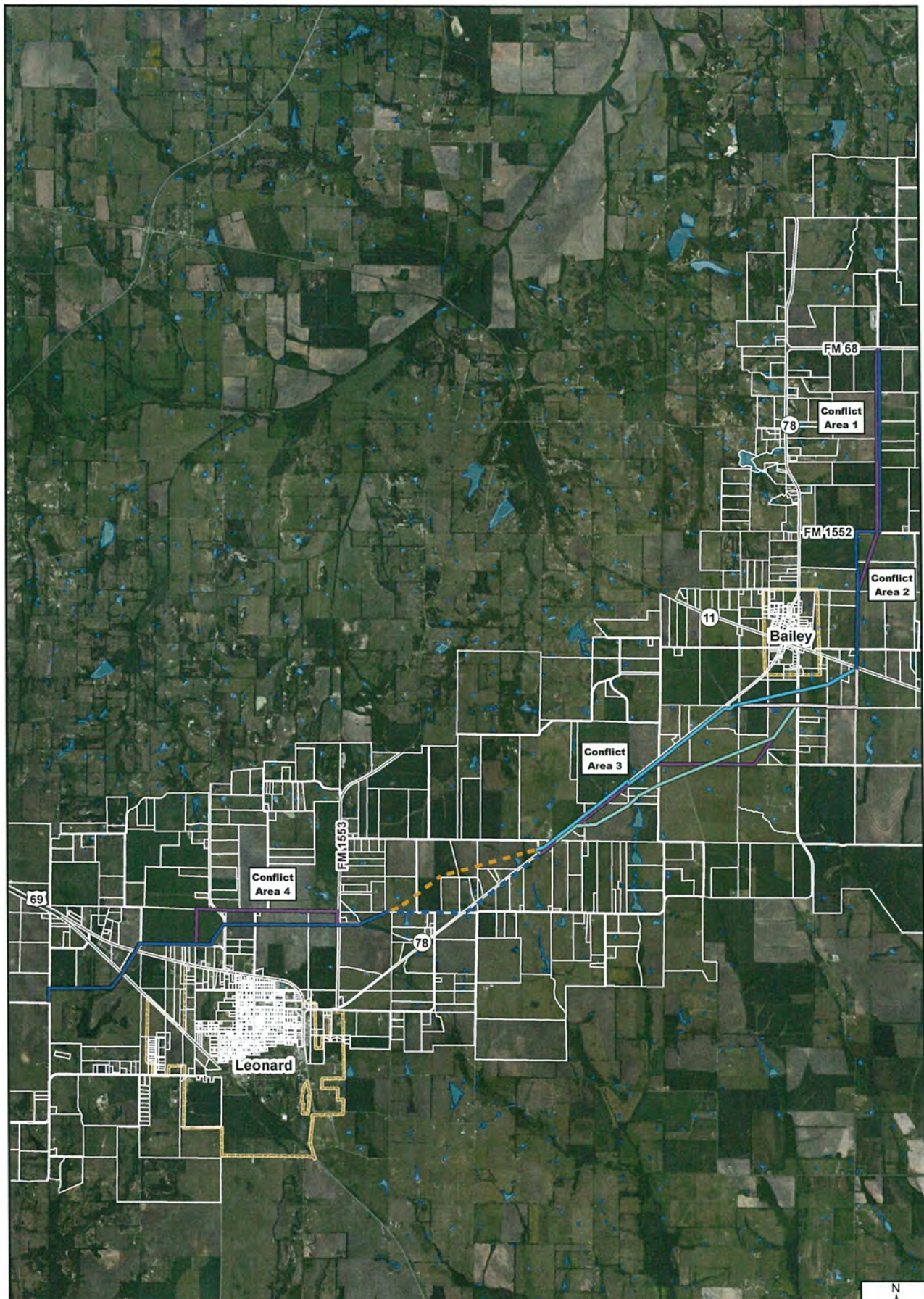

Source: Esri, DigitalGlobe, GeoEye, AeroGRID, USDA, USGS, AeroGRID, IGN, and the GIS User Community

PROJECT NO: NT013106
 DATE CREATED: 10/4/2013
 DATUM & COORDINATE SYSTEM: NAD83 State Plane (feet) Texas North Central
 FILE NAME: SectionC_corridor.mxd
 PREPARED BY: RP



NORTH TEXAS MUNICIPAL WATER DISTRICT
Lower Bois d'Arc Creek Reservoir Raw Water Pipeline
Section C Corridor

FREESE NICHOLS
 10497 TOWN AND COUNTRY WAY
 SUITE 600
 HOUSTON, TEXAS 77024
 P: 713-600-6800
 F: 713-600-6801

Section
 C
 Exhibit
 1

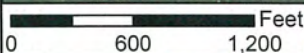
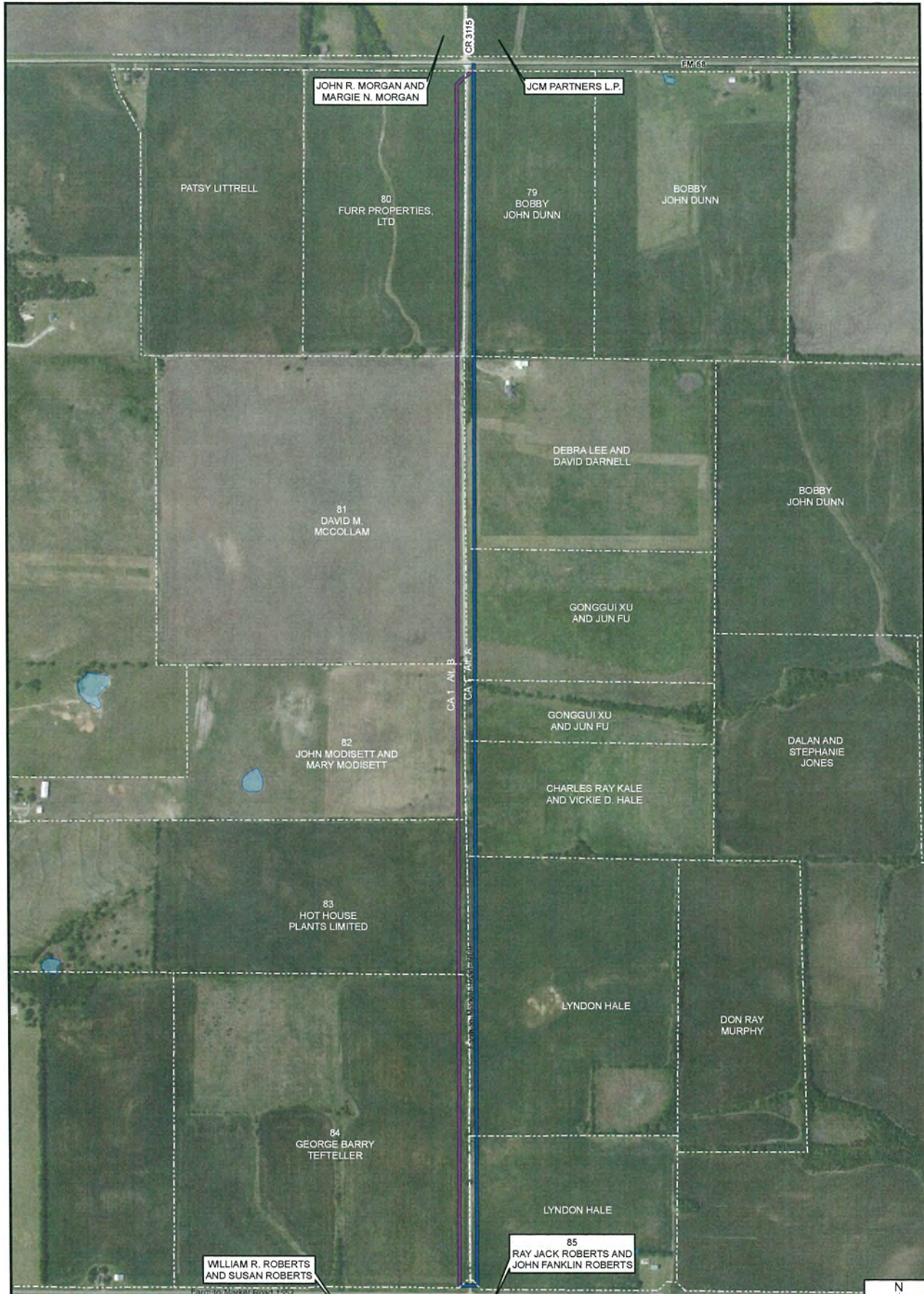

Source: Esri, DigitalGlobe, GeoEye, Earthstar USGS, USGS, Aero, GEBCO, CNES, IGN, Swisstopo, The GIS User Community



PROJECT NO.	NTD13108
DATE CREATED	06/11/2013
BY	ESRI
FILE NAME	Section_C_Corridor.mxd
PREPARED BY	RP



NORTH TEXAS MUNICIPAL WATER DISTRICT
Lower Bois d'Arc Creek Reservoir Raw Water Pipeline
Section C Corridor - Conflict Area #1

FREES NICHOLS
 10497 TOWN AND COUNTRY WAY
 SUITE 800
 HOUSTON, TEXAS 77024
 P: 713-600-6800
 F: 713-600-6801

Section
 C
 Exhibit
 2

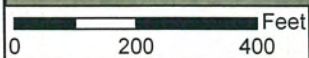
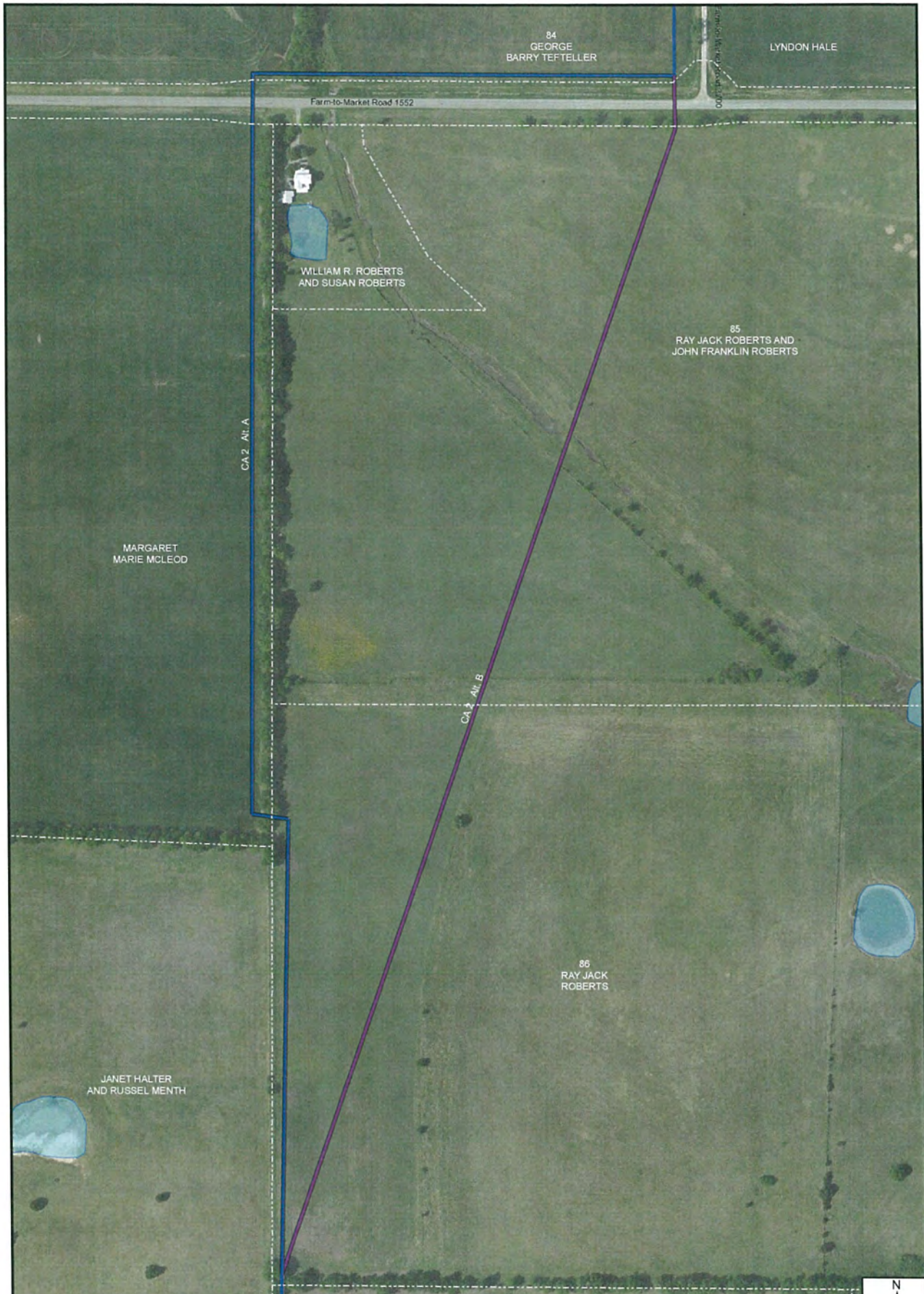

Source: Esri, DigitalGlobe, GeoEye, AeroGRID, USDA, USGS, AEX, Getmapping, Aerogrid, swisstopo, and the GIS User Community



PROJECT NO.	NTD13106
DATE CREATED	04/11/2013
DRAWN & CHECKED BY	DF/STC
SACS State Plane (ft): Texas North Central	
FILE NAME	SectionC_CA2.mxd
PREPARED BY	RP



NORTH TEXAS MUNICIPAL WATER DISTRICT
Lower Bois d'Arc Creek Reservoir Raw Water Pipeline
Section C Corridor - Conflict Area #2

FREES NICHOLS
 10497 TOWN AND COUNTRY WAY
 SUITE 600
 HOUSTON, TEXAS 77024
 P: 713-600-6800
 F: 713-600-6801

Section
 C
 Exhibit
 3

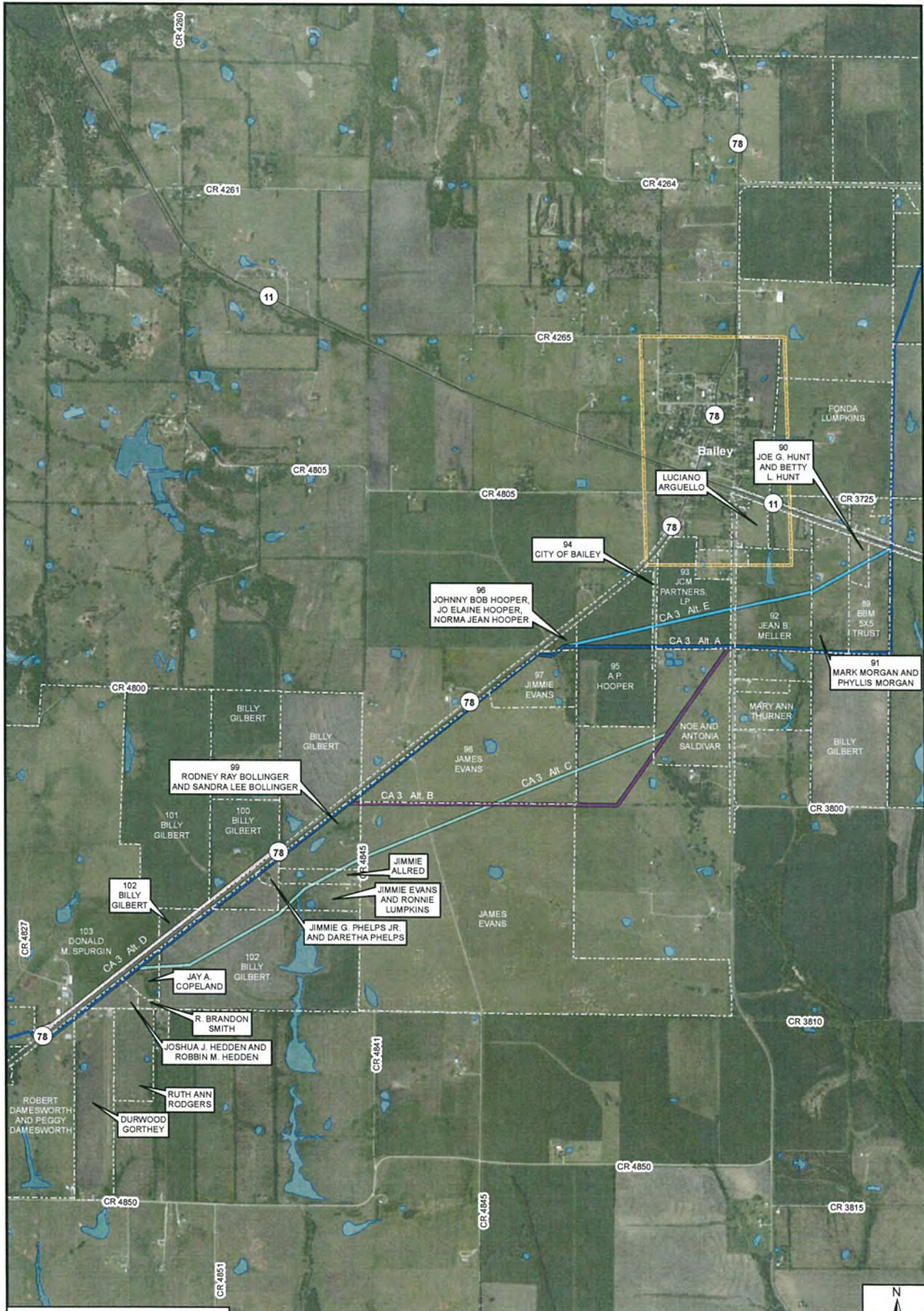

Source: Esri, DigitalGlobe, GeoEye, Earthstar (USA), USGS, AeroGRID, IGN, and the GIS User Community

PROJECT NO.	NTD13136
DATE CREATED	Date: 11/02/2013
PROJECT COORDINATE SYSTEM	NAD83 StatePlane (feet) Texas North Central
FILE NAME	SectionC_CAD.mxd
PREPARED BY	BP



NORTH TEXAS MUNICIPAL WATER DISTRICT
Lower Bois d'Arc Creek Reservoir Raw Water Pipeline
Section C Corridor - Conflict Area #3

FREESE NICHOLS
 10497 TOWN AND COUNTRY WAY
 SUITE 600
 HOUSTON, TEXAS 77024
 P: 713-600-6800
 F: 713-600-6801

Section
 C
 Exhibit
 4

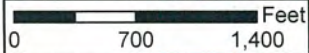

PROJECT NO: NT013106
 DATE CREATED: 11/02/2013
 AUTHOR & COORDINATOR: J. BISHOP
 MDCS State Plane (feet) Texas North Central
 FILE NAME: Section_C_CA #4.mxd
 PREPARED BY: RP



NORTH TEXAS MUNICIPAL WATER DISTRICT
 Lower Bois d'Arc Creek Reservoir Raw Water Pipeline
 Section C Corridor - Conflict Area #4

FREESE NICHOLS
 10497 TOWN AND COUNTRY WAY
 SUITE 600
 HOUSTON, TEXAS 77024
 P: 713-600-6800
 F: 713-600-6801

Section
 C
 Exhibit
 5

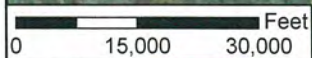
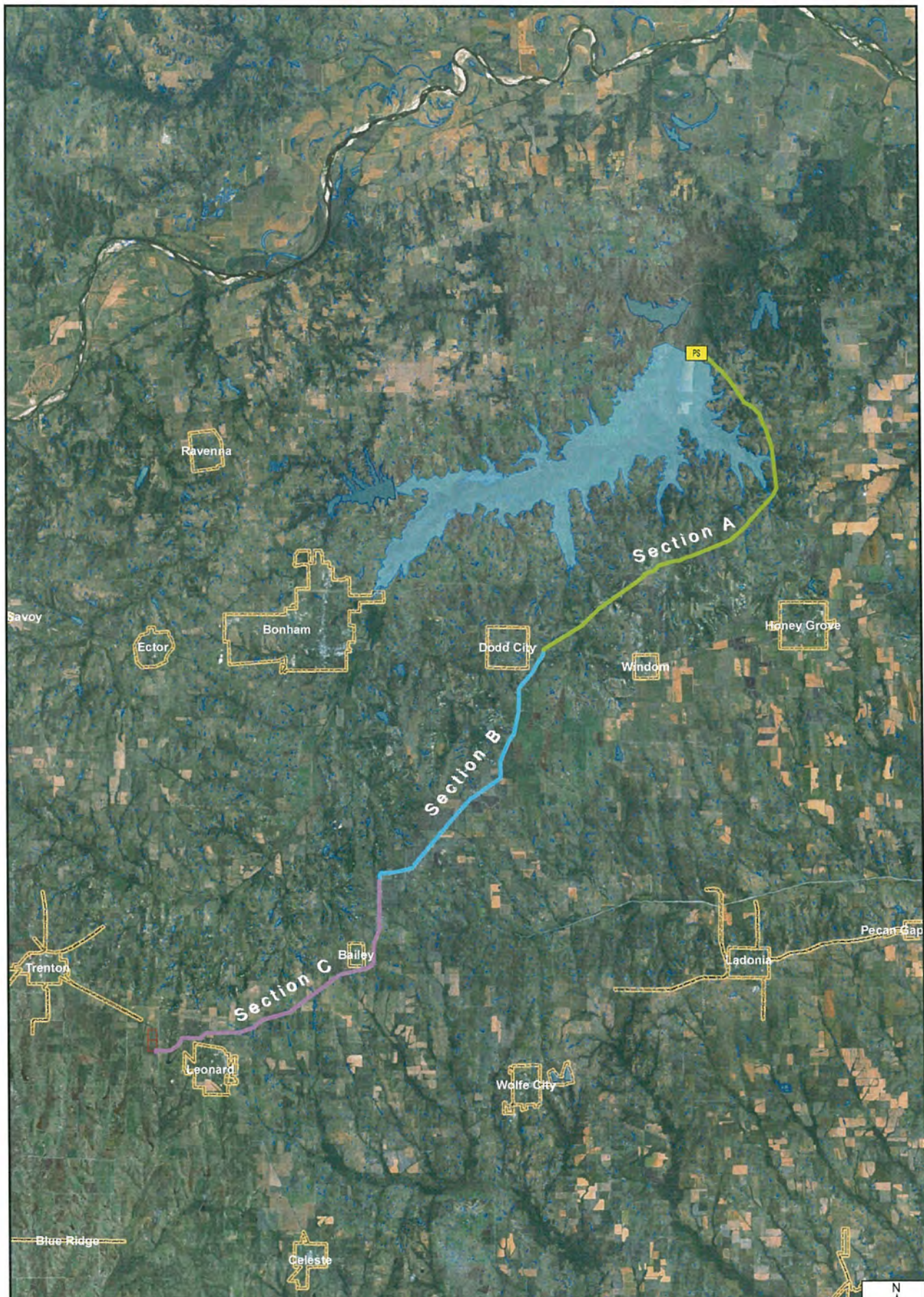

Source: Esri, DigitalGlobe, GeoEye, USDA, USGS, Aero, GeoEye, IGN, Aerotech, Earthstar, and the GIS User Community

PROJECT NO.	NTD10138
DATE CREATED	Date: 10/04/2013
PROJECT COORDINATE SYSTEM	GAD83 State Plane (feet) Texas North Central
FILE NAME	Overall_align(201313)
PREPARED BY	RP



NORTH TEXAS MUNICIPAL WATER DISTRICT
Lower Bois d'Arc Creek Reservoir Raw Water Pipeline
Overall Recommended Alignment

FREESE NICHOLS
 10497 TOWN AND COUNTRY WAY
 SUITE 600
 HOUSTON, TEXAS 77024
 P: 713-600-6800
 F: 713-600-6801



Overall Pipeline
 Exhibit
 2



APPENDIX B
HYDRAULICS DATA

90" Raw Water Pipeline
Lower Bois d'Arc Reservoir to Leonard WTP Site
TSR Site 1, Max WSE (El. 731)

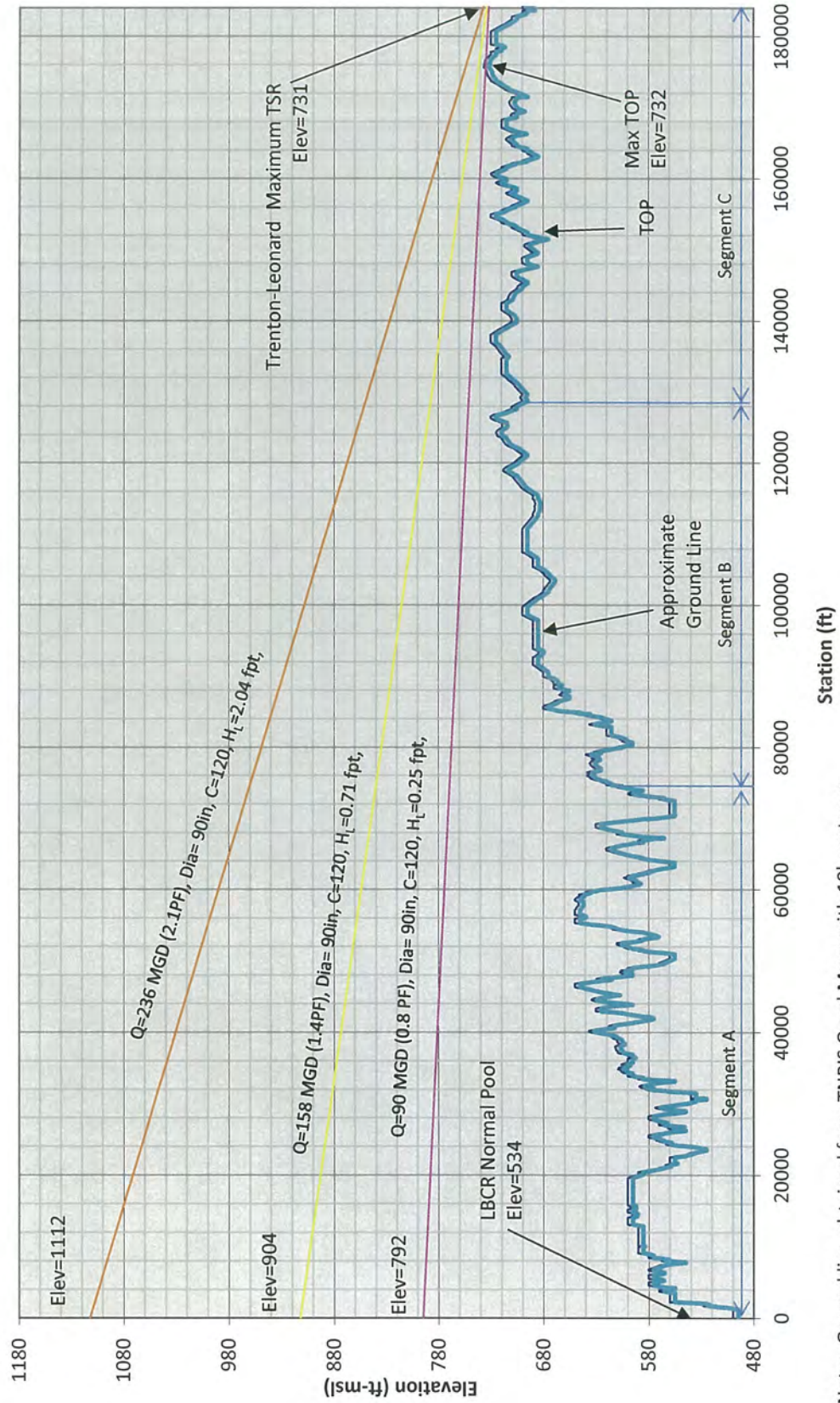

Note: Ground line obtained from TNRS Quad Maps with 10' contours.

90" Raw Water Pipeline Lower Bois d'Arc Reservoir to Leonard WTP Site TSR Site 1, Max WSE (El. 731)

Pipe Class Lengths:
 (Q=236 MGD)
 300 psi: 2,500ft
 250 psi: 37,100ft
 200 psi: 43,700ft
 150 psi: 103,800 ft

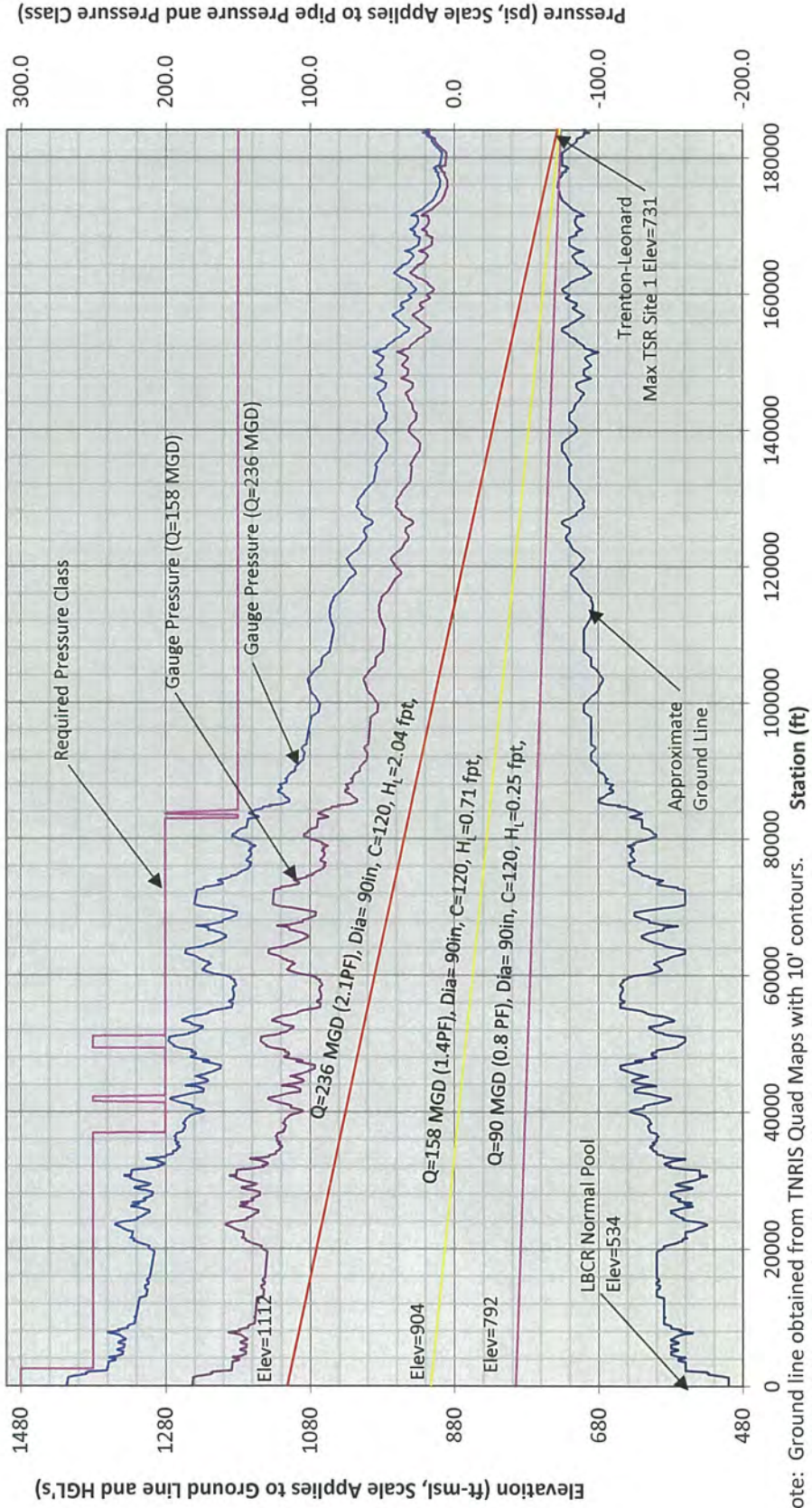

Note: Ground line obtained from TNRI's Quad Maps with 10' contours.
 NTMWD Minimum pipe class is 150 psi

**96" Raw Water Pipeline
Lower Bois d'Arc Reservoir to Leonard WTP Site
TSR Site 1, Max WSE (El. 731)**

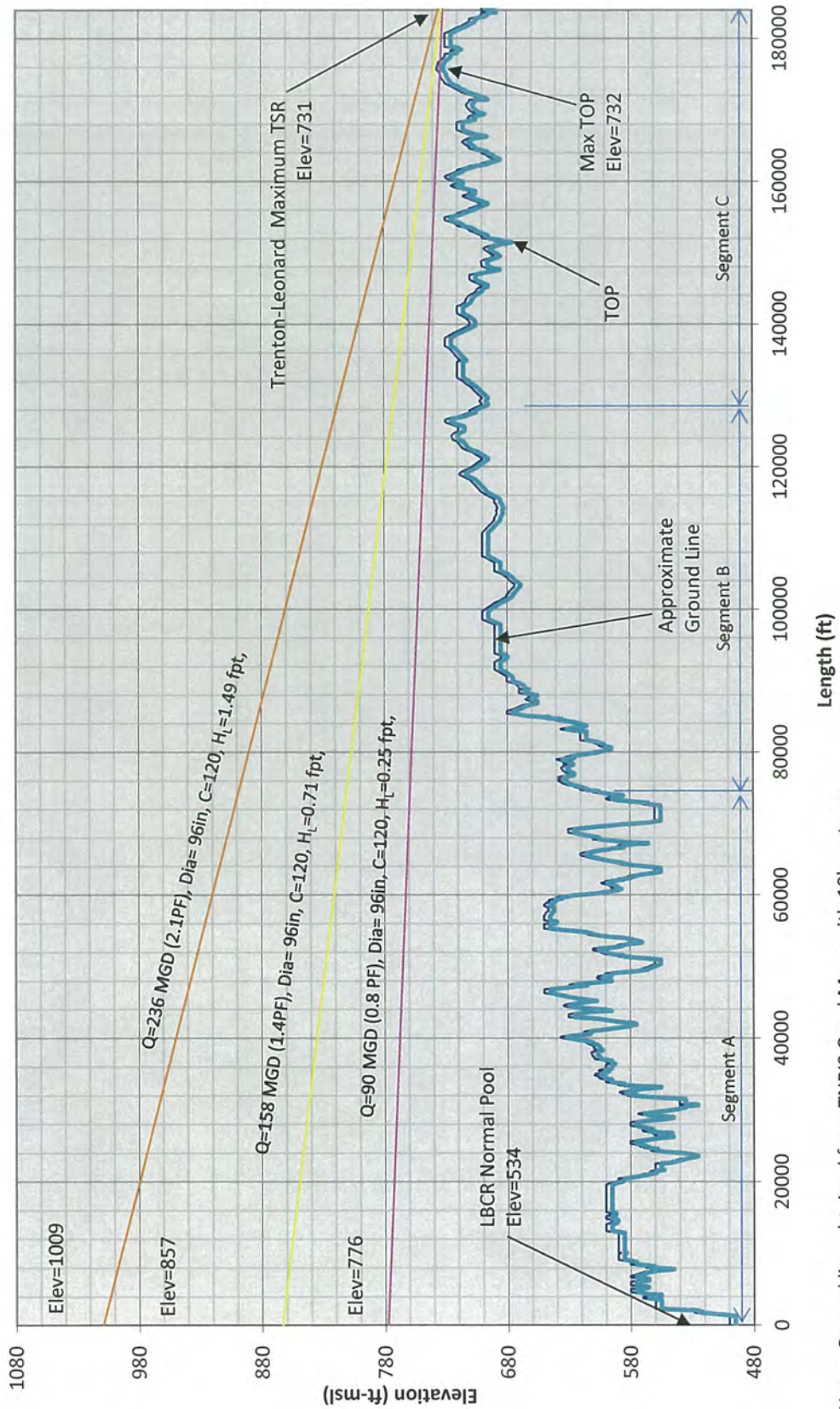

Note: Ground line obtained from TNRIS Quad Maps with 10' contours.

96" Raw Water Pipeline Lower Bois d'Arc Reservoir to Leonard WTP Site TSR Site 1, Max WSE (El. 731)

Pipe Class Lengths:
 (Q=236 MGD)
 300 psi: 0ft
 250 psi: 6050ft
 200 psi: 53,650ft
 150 psi: 127,400 ft

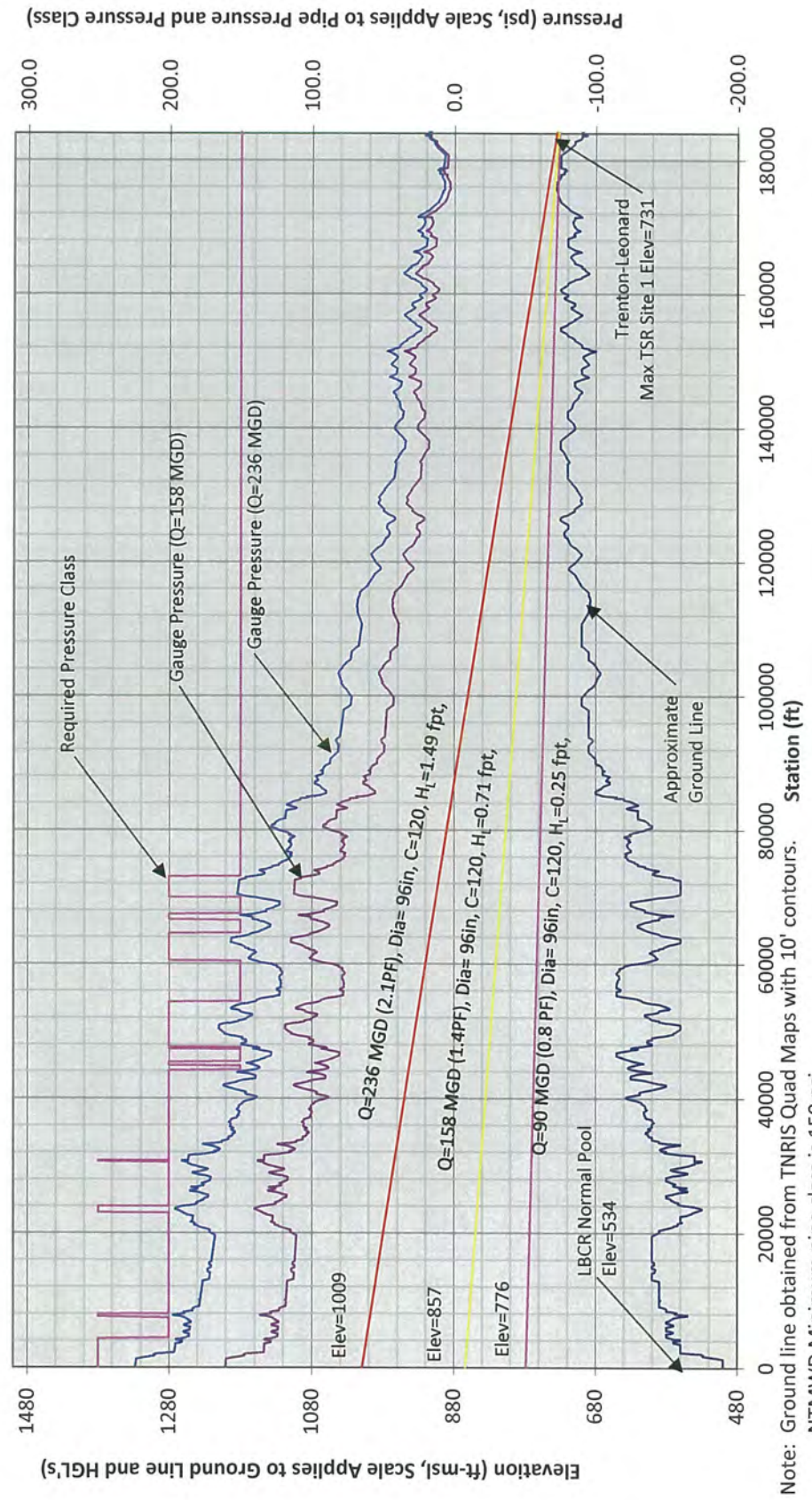

Note: Ground line obtained from TNRIS Quad Maps with 10' contours.
 NTMWD Minimum pipe class is 150 psi

North Texas Municipal Water District
Lower Bois d'Arc Creek Reservoir Water Supply Project
Pipeline Diameter Optimization
Terminal Storage Reservoir Site 1

Assumptions:

Raw Water Pipeline
 1.4 PF (158 MGD) for  4 months
 0.8 PF (90 MGD) for  8 months
 Average Flow (MGD) 110

Parameters	Pipe Diameter					
	78	84	90	96	102	108
Peak Flow Velocity Check						
Peak Flow, MGD (2.145 PF)	236	236	236	236	236	236
Peak Velocity, fps	10.95	9.42	8.23	7.23	6.40	5.71
Design Flows						
1.4 PF Flow, MGD	158	158	158	158	158	158
1.4 PF Velocity, fps	7	6.32	5.51	5	4	4
0.8 PF Flow, MGD	90	90	90	90	90	90
0.8 PF Velocity, fps	4.18	3.60	3.14	2.76	2.44	2.18
Elevation Data						
Max. Site 2 TSR Elev, ft-msl	731	731	731	731	731	731
LBCR Normal Lake Elev, ft-msl	534	534	534	534	534	534
Pipe Data						
Pressure Pipe Length, ft	187,605	187,605	187,605	187,605	187,605	187,605
Pipe Length, ft	187,605	187,605	187,605	187,605	187,605	187,605
H-W C Factor	120	120	120	120	120	120
Pump Head Calculation (1.4 PF)						
Static Head, ft	197	197	197	197	197	197
Friction Head, ft	366	256	183	133	99	75
Total Head, ft	563	453	380	330	296	272
Pump Head Calculation (0.8 PF)						
Static Head, ft	197	197	197	197	197	197
Friction Head, ft	129	90	64	47	35	27
Total Head, ft	326	287	261	244	232	224
Power Required (1.4 PF)						
Wire-to-Water Efficiency, %	75	74	75	75	75	75
Horsepower	20,838	16,961	14,041	12,220	10,960	10,068
kW	15,539	12,648	10,470	9,113	8,173	7,508
Days operating per year (3 mo)	90	89	90	90	90	90
Hours per year	2,160	2,136	2,160	2,160	2,160	2,160
kWh/yr	33,563,767	27,016,439	22,615,539	19,683,369	17,653,018	16,216,251
Power Required (0.8 PF)						
Wire-to-Water Efficiency, %	75	74	75	75	75	75
Horsepower	6,875	6,132	5,509	5,142	4,889	4,710
kW	5,127	4,573	4,108	3,835	3,646	3,512
Days operating per year (9 mo)	275	274	275	275	275	275
Hours per year	6,600	6,576	6,600	6,600	6,600	6,600
kWh/yr	33,838,313	30,070,454	27,110,833	25,309,069	24,061,457	23,178,590
Pipe Cost (2021 Dollars)	\$ 148,295,098	\$ 169,683,814	\$ 192,498,445	\$ 216,738,990	\$ 242,405,449	\$ 282,331,053
Total Present Worth (50 yr LCCA)	\$ 509,616,901	\$ 475,802,222	\$ 463,620,281	\$ 465,470,732	\$ 476,890,428	\$ 509,799,096

Life Cycle Cost Analysis Variables		
Assumed Variables		
Lake Level		534
TSR Elevation		731
Static Head		197
Pipe Diameter (in)		78
Friction Factor, C		120
Pressure Pipe Length (ft)		187605
Peaking Factor 1		1.4
PF 1 Duration (Mo)		4
Peaking Factor 2		0.8
PF 2 Duration (Mo)		8
Power Variables		
Electricity Cost (kW-hr)	\$	0.05
Run Time (PF 1, hrs)		2920
Run Time (PF 2, hrs)		5840
Pumping Efficiency		75%
Financial Variables		
Bond Interest Rate		4.50%
Bond Term (yrs)		25
Discount Rate		5%
Inflation Rate		3%
Construction Cost		
\$/dia-in/ft	\$	8.00
Construction Cost	\$	117,065,520.00
Inflated Const. Cost (2021 Dollars)	\$	148,295,098.30

			Average		
			Year	Sequence	Surface Water Delivered (MGD)
70 MGD WTP			2021	8	
			2022	9	
			2023	10	40
			2024	11	40
			2025	12	40
Expand to 140 MGD WTP			2026	13	40
			2027	14	50
			2028	15	60
			2029	16	70
Expand to 210 MGD WTP			2030	17	80
			2031	18	88
			2032	19	96
			2033	20	104
Expand to 280 MGD WTP			2034	21	110
			2035	22	110
			2036	23	110
			2037	24	110
		2038	25	110	
		2039	26	110	
		2040	27	110	
		2041	28	110	
		2042	29	110	
		2043	30	110	
		2044	31	110	
		2045	32	110	
		2046	33	110	
		2047	34	110	
		2048	35	110	
		2049	36	110	
		2050	37	110	
		2051	38	110	
		2052	39	110	
		2053	40	110	
		2054	41	110	
		2055	42	110	
		2056	43	110	
		2057	44	110	
		2058	45	110	
		2059	46	110	
		2060	47	110	
		2061	48	110	
		2062	49	110	
		2063	50	110	
		2064	51	110	
		2065	52	110	
		2066	53	110	
		2067	54	110	
		2068	55	110	
		2069	56	110	
		2070	57	110	

Total Cost				
Total Power	Inflated Power	Debt Service	Total Cost	Present Worth
Cost (\$)	Cost (\$)	(\$)	(\$)	(\$)
715,777.99	\$ 906,726.14	\$10,001,000.00	\$ 10,907,726.14	\$ 7,382,778.40
715,777.99	\$ 933,927.93	\$10,001,000.00	\$ 10,934,927.93	\$ 7,401,189.64
\$ 715,777.99	\$ 961,945.76	\$10,001,000.00	\$ 10,962,945.76	\$ 7,420,153.22
\$ 715,777.99	\$ 990,804.14	\$10,001,000.00	\$ 10,991,804.14	\$ 7,439,685.70
\$ 715,777.99	\$ 1,020,528.26	\$10,001,000.00	\$ 11,021,528.26	\$ 7,459,804.16
\$ 715,777.99	\$ 1,051,144.11	\$10,001,000.00	\$ 11,052,144.11	\$ 7,480,526.17
\$ 973,562.93	\$ 1,472,601.29	\$10,001,000.00	\$ 11,473,601.29	\$ 7,765,784.97
\$ 1,280,489.18	\$ 1,994,960.41	\$10,001,000.00	\$ 11,995,960.41	\$ 8,119,338.19
\$ 1,644,801.62	\$ 2,639,423.76	\$10,001,000.00	\$ 12,640,423.76	\$ 8,555,536.35
\$ 2,074,539.47	\$ 3,428,897.65	\$10,001,000.00	\$ 13,429,897.65	\$ 9,089,883.36
\$ 2,470,728.08	\$ 4,206,249.17	\$10,001,000.00	\$ 14,207,249.17	\$ 9,616,025.46
\$ 2,917,786.42	\$ 5,116,356.16	\$10,001,000.00	\$ 15,117,356.16	\$ 10,232,021.70
\$ 3,419,620.21	\$ 6,176,214.47	\$10,001,000.00	\$ 16,177,214.47	\$ 10,949,375.52
\$ 3,834,263.89	\$ 7,132,860.30	\$10,001,000.00	\$ 17,133,860.30	\$ 11,596,871.08
\$ 3,834,263.89	\$ 7,346,846.11	\$10,001,000.00	\$ 17,347,846.11	\$ 11,741,705.10
\$ 3,834,263.89	\$ 7,567,251.50	\$10,001,000.00	\$ 17,568,251.50	\$ 11,890,884.13
\$ 3,834,263.89	\$ 7,794,269.04	\$10,001,000.00	\$ 17,795,269.04	\$ 12,044,538.54
\$ 3,834,263.89	\$ 8,028,097.11	\$10,001,000.00	\$ 18,029,097.11	\$ 12,202,802.59
\$ 3,834,263.89	\$ 8,268,940.03	\$10,001,000.00	\$ 18,269,940.03	\$ 12,365,814.55
\$ 3,834,263.89	\$ 8,517,008.23	\$10,001,000.00	\$ 18,518,008.23	\$ 12,533,716.87
\$ 3,834,263.89	\$ 8,772,518.47	\$10,001,000.00	\$ 18,773,518.47	\$ 12,706,656.27
\$ 3,834,263.89	\$ 9,035,694.03	\$10,001,000.00	\$ 19,036,694.03	\$ 12,884,783.84
\$ 3,834,263.89	\$ 9,306,764.85	\$10,001,000.00	\$ 19,307,764.85	\$ 13,068,255.24
\$ 3,834,263.89	\$ 9,585,967.79	\$10,001,000.00	\$ 19,586,967.79	\$ 13,257,230.79
\$ 3,834,263.89	\$ 9,873,546.83	\$10,001,000.00	\$ 19,874,546.83	\$ 13,451,875.59
\$ 3,834,263.89	\$ 10,169,753.23	\$0.00	\$ 10,169,753.23	\$ 6,883,289.29
\$ 3,834,263.89	\$ 10,474,845.83	\$0.00	\$ 10,474,845.83	\$ 7,089,787.97
\$ 3,834,263.89	\$ 10,789,091.20	\$0.00	\$ 10,789,091.20	\$ 7,302,481.61
\$ 3,834,263.89	\$ 11,112,763.94	\$0.00	\$ 11,112,763.94	\$ 7,521,556.06
\$ 3,834,263.89	\$ 11,446,146.86	\$0.00	\$ 11,446,146.86	\$ 7,747,202.74
\$ 3,834,263.89	\$ 11,789,531.26	\$0.00	\$ 11,789,531.26	\$ 7,979,618.82
\$ 3,834,263.89	\$ 12,143,217.20	\$0.00	\$ 12,143,217.20	\$ 8,219,007.38
\$ 3,834,263.89	\$ 12,507,513.72	\$0.00	\$ 12,507,513.72	\$ 8,465,577.60
\$ 3,834,263.89	\$ 12,882,739.13	\$0.00	\$ 12,882,739.13	\$ 8,719,544.93
\$ 3,834,263.89	\$ 13,269,221.30	\$0.00	\$ 13,269,221.30	\$ 8,981,131.28
\$ 3,834,263.89	\$ 13,667,297.94	\$0.00	\$ 13,667,297.94	\$ 9,250,565.22
\$ 3,834,263.89	\$ 14,077,316.88	\$0.00	\$ 14,077,316.88	\$ 9,528,082.18
\$ 3,834,263.89	\$ 14,499,636.39	\$0.00	\$ 14,499,636.39	\$ 9,813,924.64
\$ 3,834,263.89	\$ 14,934,625.48	\$0.00	\$ 14,934,625.48	\$ 10,108,342.38
\$ 3,834,263.89	\$ 15,382,664.24	\$0.00	\$ 15,382,664.24	\$ 10,411,592.65
\$ 3,834,263.89	\$ 15,844,144.17	\$0.00	\$ 15,844,144.17	\$ 10,723,940.43
\$ 3,834,263.89	\$ 16,319,468.49	\$0.00	\$ 16,319,468.49	\$ 11,045,658.64
\$ 3,834,263.89	\$ 16,809,052.55	\$0.00	\$ 16,809,052.55	\$ 11,377,028.40
\$ 3,834,263.89	\$ 17,313,324.13	\$0.00	\$ 17,313,324.13	\$ 11,718,339.26
\$ 3,834,263.89	\$ 17,832,723.85	\$0.00	\$ 17,832,723.85	\$ 12,069,889.43
\$ 3,834,263.89	\$ 18,367,705.57	\$0.00	\$ 18,367,705.57	\$ 12,431,986.12
\$ 3,834,263.89	\$ 18,918,736.73	\$0.00	\$ 18,918,736.73	\$ 12,804,945.70
\$ 3,834,263.89	\$ 19,486,298.83	\$0.00	\$ 19,486,298.83	\$ 13,189,094.07
\$ 3,834,263.89	\$ 20,070,887.80	\$0.00	\$ 20,070,887.80	\$ 13,584,766.89
\$ 3,834,263.89	\$ 20,673,014.43	\$0.00	\$ 20,673,014.43	\$ 13,992,309.90
Total			\$ 752,936,264.68	\$ 509,616,901.03

Life Cycle Cost Analysis Variables

Assumed Variables

Lake Level	534
TSR Elevation	731
Static Head	197
Pipe Diameter (in)	84
Friction Factor, C	120
Pressure Pipe Length (ft)	187605
Peaking Factor 1	1.4
PF 1 Duration (Mo)	4
Peaking Factor 2	0.8
PF 2 Duration (Mo)	8

Power Variables

Electricity Cost (kW-hr)	\$	0.05
Run Time (PF 1, hrs)		2920
Run Time (PF 2, hrs)		5840
Pumping Efficiency		75%

Financial Variables

Bond Interest Rate	4.50%
Bond Term (yrs)	25
Discount Rate	5%
Inflation Rate	3%

Construction Cost

\$/dia-in/ft	\$	8.50
Construction Cost	\$	133,949,970.00
Inflated Const. Cost (2021 Dollars)	\$	169,683,814.40

70 MGD WTP

Expand to 140 MGD WTP

Expand to 210 MGD WTP

Expand to 280 MGD WTP

Average		
Year	Sequence	Surface Water Delivered (MGD)
2021	8	40
2022	9	40
2023	10	40
2024	11	40
2025	12	40
2026	13	40
2027	14	50
2028	15	60
2029	16	70
2030	17	80
2031	18	88
2032	19	96
2033	20	104
2034	21	110
2035	22	110
2036	23	110
2037	24	110
2038	25	110
2039	26	110
2040	27	110
2041	28	110
2042	29	110
2043	30	110
2044	31	110
2045	32	110
2046	33	110
2047	34	110
2048	35	110
2049	36	110
2050	37	110
2051	38	110
2052	39	110
2053	40	110
2054	41	110
2055	42	110
2056	43	110
2057	44	110
2058	45	110
2059	46	110
2060	47	110
2061	48	110
2062	49	110
2063	50	110
2064	51	110
2065	52	110
2066	53	110
2067	54	110
2068	55	110
2069	56	110
2070	57	110

Total Cost				
Total Power	Inflated Power	Debt Service	Total Cost	Present Worth
Cost (\$)	Cost (\$)	(\$)	(\$)	(\$)
678,389.28	\$ 859,363.25	\$11,443,000.00	\$ 12,302,363.25	\$ 8,326,723.69
678,389.28	\$ 885,144.15	\$11,443,000.00	\$ 12,328,144.15	\$ 8,344,173.22
\$ 678,389.28	\$ 911,698.47	\$11,443,000.00	\$ 12,354,698.47	\$ 8,362,146.23
\$ 678,389.28	\$ 939,049.42	\$11,443,000.00	\$ 12,382,049.42	\$ 8,380,658.43
\$ 678,389.28	\$ 967,220.91	\$11,443,000.00	\$ 12,410,220.91	\$ 8,399,726.00
\$ 678,389.28	\$ 996,237.53	\$11,443,000.00	\$ 12,439,237.53	\$ 8,419,365.60
\$ 902,941.91	\$ 1,365,780.66	\$11,443,000.00	\$ 12,808,780.66	\$ 8,669,486.93
\$ 1,161,748.23	\$ 1,809,965.88	\$11,443,000.00	\$ 13,252,965.88	\$ 8,970,128.97
\$ 1,460,555.28	\$ 2,343,762.47	\$11,443,000.00	\$ 13,786,762.47	\$ 9,331,423.51
\$ 1,804,966.76	\$ 2,983,335.04	\$11,443,000.00	\$ 14,426,335.04	\$ 9,764,311.41
\$ 2,117,019.92	\$ 3,604,084.71	\$11,443,000.00	\$ 15,047,084.71	\$ 10,184,459.22
\$ 2,464,531.56	\$ 4,321,571.01	\$11,443,000.00	\$ 15,764,571.01	\$ 10,670,082.19
\$ 2,850,224.12	\$ 5,147,821.81	\$11,443,000.00	\$ 16,590,821.81	\$ 11,229,321.25
\$ 3,166,168.29	\$ 5,890,005.69	\$11,443,000.00	\$ 17,333,005.69	\$ 11,731,660.51
\$ 3,166,168.29	\$ 6,066,705.86	\$11,443,000.00	\$ 17,509,705.86	\$ 11,851,258.14
\$ 3,166,168.29	\$ 6,248,707.04	\$11,443,000.00	\$ 17,691,707.04	\$ 11,974,443.70
\$ 3,166,168.29	\$ 6,436,168.25	\$11,443,000.00	\$ 17,879,168.25	\$ 12,101,324.83
\$ 3,166,168.29	\$ 6,629,253.29	\$11,443,000.00	\$ 18,072,253.29	\$ 12,232,012.39
\$ 3,166,168.29	\$ 6,828,130.89	\$11,443,000.00	\$ 18,271,130.89	\$ 12,366,620.58
\$ 3,166,168.29	\$ 7,032,974.82	\$11,443,000.00	\$ 18,475,974.82	\$ 12,505,267.01
\$ 3,166,168.29	\$ 7,243,964.06	\$11,443,000.00	\$ 18,686,964.06	\$ 12,648,072.84
\$ 3,166,168.29	\$ 7,461,282.99	\$11,443,000.00	\$ 18,904,282.99	\$ 12,795,162.84
\$ 3,166,168.29	\$ 7,685,121.48	\$11,443,000.00	\$ 19,128,121.48	\$ 12,946,665.54
\$ 3,166,168.29	\$ 7,915,675.12	\$11,443,000.00	\$ 19,358,675.12	\$ 13,102,713.32
\$ 3,166,168.29	\$ 8,153,145.37	\$11,443,000.00	\$ 19,596,145.37	\$ 13,263,442.53
\$ 3,166,168.29	\$ 8,397,739.73	\$0.00	\$ 8,397,739.73	\$ 5,683,920.80
\$ 3,166,168.29	\$ 8,649,671.93	\$0.00	\$ 8,649,671.93	\$ 5,854,438.43
\$ 3,166,168.29	\$ 8,909,162.08	\$0.00	\$ 8,909,162.08	\$ 6,030,071.58
\$ 3,166,168.29	\$ 9,176,436.95	\$0.00	\$ 9,176,436.95	\$ 6,210,973.73
\$ 3,166,168.29	\$ 9,451,730.06	\$0.00	\$ 9,451,730.06	\$ 6,397,302.94
\$ 3,166,168.29	\$ 9,735,281.96	\$0.00	\$ 9,735,281.96	\$ 6,589,222.03
\$ 3,166,168.29	\$ 10,027,340.42	\$0.00	\$ 10,027,340.42	\$ 6,786,898.69
\$ 3,166,168.29	\$ 10,328,160.63	\$0.00	\$ 10,328,160.63	\$ 6,990,505.65
\$ 3,166,168.29	\$ 10,638,005.45	\$0.00	\$ 10,638,005.45	\$ 7,200,220.82
\$ 3,166,168.29	\$ 10,957,145.61	\$0.00	\$ 10,957,145.61	\$ 7,416,227.44
\$ 3,166,168.29	\$ 11,285,859.98	\$0.00	\$ 11,285,859.98	\$ 7,638,714.27
\$ 3,166,168.29	\$ 11,624,435.78	\$0.00	\$ 11,624,435.78	\$ 7,867,875.70
\$ 3,166,168.29	\$ 11,973,168.85	\$0.00	\$ 11,973,168.85	\$ 8,103,911.97
\$ 3,166,168.29	\$ 12,332,363.92	\$0.00	\$ 12,332,363.92	\$ 8,347,029.33
\$ 3,166,168.29	\$ 12,702,334.83	\$0.00	\$ 12,702,334.83	\$ 8,597,440.21
\$ 3,166,168.29	\$ 13,083,404.88	\$0.00	\$ 13,083,404.88	\$ 8,855,363.41
\$ 3,166,168.29	\$ 13,475,907.03	\$0.00	\$ 13,475,907.03	\$ 9,121,024.31
\$ 3,166,168.29	\$ 13,880,184.24	\$0.00	\$ 13,880,184.24	\$ 9,394,655.04
\$ 3,166,168.29	\$ 14,296,589.76	\$0.00	\$ 14,296,589.76	\$ 9,676,494.69
\$ 3,166,168.29	\$ 14,725,487.46	\$0.00	\$ 14,725,487.46	\$ 9,966,789.54
\$ 3,166,168.29	\$ 15,167,252.08	\$0.00	\$ 15,167,252.08	\$ 10,265,793.22
\$ 3,166,168.29	\$ 15,622,269.64	\$0.00	\$ 15,622,269.64	\$ 10,573,767.02
\$ 3,166,168.29	\$ 16,090,937.73	\$0.00	\$ 16,090,937.73	\$ 10,890,980.03
\$ 3,166,168.29	\$ 16,573,665.86	\$0.00	\$ 16,573,665.86	\$ 11,217,709.43
\$ 3,166,168.29	\$ 17,070,875.84	\$0.00	\$ 17,070,875.84	\$ 11,554,240.71
Total			\$ 702,976,582.85	\$ 475,802,221.85

Life Cycle Cost Analysis Variables		
Assumed Variables		
Lake Level		534
TSR Elevation		731
Static Head		197
Pipe Diameter (in)		90
Friction Factor, C		120
Pressure Pipe Length (ft)		187605
Peaking Factor 1		1.4
PF 1 Duration (Mo)		4
Peaking Factor 2		0.8
PF 2 Duration (Mo)		8
Power Variables		
Electricity Cost (kW-hr)	\$	0.05
Run Time (PF 1, hrs)		2920
Run Time (PF 2, hrs)		5840
Pumping Efficiency		75%
Financial Variables		
Bond Interest Rate		4.50%
Bond Term (yrs)		25
Discount Rate		5%
Inflation Rate		3%
Construction Cost		
\$/dia-in/ft	\$	9.00
Construction Cost	\$	151,960,050.00
Inflated Const. Cost (2021 Dollars)	\$	192,498,444.91

			Average		
			Year	Sequence	Surface Water Delivered (MGD)
70 MGD WTP			2021	8	39
			2022	9	45
			2023	10	40
			2024	11	40
			2025	12	40
Expand to 140 MGD WTP			2026	13	40
			2027	14	50
			2028	15	60
			2029	16	70
Expand to 210 MGD WTP			2030	17	80
			2031	18	88
			2032	19	96
Expand to 280 MGD WTP			2033	20	104
			2034	21	110
			2035	22	110
			2036	23	110
			2037	24	110
			2038	25	110
			2039	26	110
			2040	27	110
			2041	28	110
			2042	29	110
			2043	30	110
			2044	31	110
			2045	32	110
			2046	33	110
			2047	34	110
			2048	35	110
			2049	36	110
			2050	37	110
		2051	38	110	
		2052	39	110	
		2053	40	110	
		2054	41	110	
		2055	42	110	
		2056	43	110	
		2057	44	110	
		2058	45	110	
		2059	46	110	
		2060	47	110	
		2061	48	110	
		2062	49	110	
		2063	50	110	
		2064	51	110	
		2065	52	110	
		2066	53	110	
		2067	54	110	
		2068	55	110	
		2069	56	110	
		2070	57	110	

Total Cost				
Total Power	Inflated Power	Debt Service	Total Cost	Present Worth
Cost (\$)	Cost (\$)	(\$)	(\$)	(\$)
653,840.16	\$ 828,265.15	\$12,982,000.00	\$ 13,810,265.15	\$ 9,347,331.05
653,840.16	\$ 853,113.10	\$12,982,000.00	\$ 13,835,113.10	\$ 9,364,149.13
\$ 653,840.16	\$ 878,706.49	\$12,982,000.00	\$ 13,860,706.49	\$ 9,381,471.74
\$ 653,840.16	\$ 905,067.69	\$12,982,000.00	\$ 13,887,067.69	\$ 9,399,314.04
\$ 653,840.16	\$ 932,219.72	\$12,982,000.00	\$ 13,914,219.72	\$ 9,417,691.60
\$ 653,840.16	\$ 960,186.31	\$12,982,000.00	\$ 13,942,186.31	\$ 9,436,620.49
\$ 856,572.71	\$ 1,295,643.08	\$12,982,000.00	\$ 14,277,643.08	\$ 9,663,670.84
\$ 1,083,783.86	\$ 1,688,499.94	\$12,982,000.00	\$ 14,670,499.94	\$ 9,929,571.82
\$ 1,339,580.60	\$ 2,149,633.61	\$12,982,000.00	\$ 15,131,633.61	\$ 10,241,685.24
\$ 1,627,967.46	\$ 2,690,782.17	\$12,982,000.00	\$ 15,672,782.17	\$ 10,607,955.88
\$ 1,884,777.96	\$ 3,208,708.31	\$12,982,000.00	\$ 16,190,708.31	\$ 10,958,508.68
\$ 2,166,928.02	\$ 3,799,721.39	\$12,982,000.00	\$ 16,781,721.39	\$ 11,358,529.60
\$ 2,476,363.18	\$ 4,472,587.35	\$12,982,000.00	\$ 17,454,587.35	\$ 11,813,951.77
\$ 2,727,502.02	\$ 5,073,957.21	\$12,982,000.00	\$ 18,055,957.21	\$ 12,220,982.56
\$ 2,727,502.02	\$ 5,226,175.93	\$12,982,000.00	\$ 18,208,175.93	\$ 12,324,010.18
\$ 2,727,502.02	\$ 5,382,961.21	\$12,982,000.00	\$ 18,364,961.21	\$ 12,430,128.63
\$ 2,727,502.02	\$ 5,544,450.04	\$12,982,000.00	\$ 18,526,450.04	\$ 12,539,430.63
\$ 2,727,502.02	\$ 5,710,783.54	\$12,982,000.00	\$ 18,692,783.54	\$ 12,652,011.69
\$ 2,727,502.02	\$ 5,882,107.05	\$12,982,000.00	\$ 18,864,107.05	\$ 12,767,970.18
\$ 2,727,502.02	\$ 6,058,570.26	\$12,982,000.00	\$ 19,040,570.26	\$ 12,887,407.43
\$ 2,727,502.02	\$ 6,240,327.37	\$12,982,000.00	\$ 19,222,327.37	\$ 13,010,427.79
\$ 2,727,502.02	\$ 6,427,537.19	\$12,982,000.00	\$ 19,409,537.19	\$ 13,137,138.77
\$ 2,727,502.02	\$ 6,620,363.31	\$12,982,000.00	\$ 19,602,363.31	\$ 13,267,651.07
\$ 2,727,502.02	\$ 6,818,974.20	\$12,982,000.00	\$ 19,800,974.20	\$ 13,402,078.75
\$ 2,727,502.02	\$ 7,023,543.43	\$12,982,000.00	\$ 20,005,543.43	\$ 13,540,539.25
\$ 2,727,502.02	\$ 7,234,249.73	\$0.00	\$ 7,234,249.73	\$ 4,896,424.97
\$ 2,727,502.02	\$ 7,451,277.23	\$0.00	\$ 7,451,277.23	\$ 5,043,317.72
\$ 2,727,502.02	\$ 7,674,815.54	\$0.00	\$ 7,674,815.54	\$ 5,194,617.26
\$ 2,727,502.02	\$ 7,905,060.01	\$0.00	\$ 7,905,060.01	\$ 5,350,455.77
\$ 2,727,502.02	\$ 8,142,211.81	\$0.00	\$ 8,142,211.81	\$ 5,510,969.45
\$ 2,727,502.02	\$ 8,386,478.16	\$0.00	\$ 8,386,478.16	\$ 5,676,298.53
\$ 2,727,502.02	\$ 8,638,072.51	\$0.00	\$ 8,638,072.51	\$ 5,846,587.49
\$ 2,727,502.02	\$ 8,897,214.68	\$0.00	\$ 8,897,214.68	\$ 6,021,985.11
\$ 2,727,502.02	\$ 9,164,131.12	\$0.00	\$ 9,164,131.12	\$ 6,202,644.66
\$ 2,727,502.02	\$ 9,439,055.06	\$0.00	\$ 9,439,055.06	\$ 6,388,724.00
\$ 2,727,502.02	\$ 9,722,226.71	\$0.00	\$ 9,722,226.71	\$ 6,580,385.72
\$ 2,727,502.02	\$ 10,013,893.51	\$0.00	\$ 10,013,893.51	\$ 6,777,797.29
\$ 2,727,502.02	\$ 10,314,310.32	\$0.00	\$ 10,314,310.32	\$ 6,981,131.21
\$ 2,727,502.02	\$ 10,623,739.63	\$0.00	\$ 10,623,739.63	\$ 7,190,565.15
\$ 2,727,502.02	\$ 10,942,451.81	\$0.00	\$ 10,942,451.81	\$ 7,406,282.10
\$ 2,727,502.02	\$ 11,270,725.37	\$0.00	\$ 11,270,725.37	\$ 7,628,470.57
\$ 2,727,502.02	\$ 11,608,847.13	\$0.00	\$ 11,608,847.13	\$ 7,857,324.68
\$ 2,727,502.02	\$ 11,957,112.54	\$0.00	\$ 11,957,112.54	\$ 8,093,044.43
\$ 2,727,502.02	\$ 12,315,825.92	\$0.00	\$ 12,315,825.92	\$ 8,335,835.76
\$ 2,727,502.02	\$ 12,685,300.70	\$0.00	\$ 12,685,300.70	\$ 8,585,910.83
\$ 2,727,502.02	\$ 13,065,859.72	\$0.00	\$ 13,065,859.72	\$ 8,843,488.16
\$ 2,727,502.02	\$ 13,457,835.51	\$0.00	\$ 13,457,835.51	\$ 9,108,792.80
\$ 2,727,502.02	\$ 13,861,570.57	\$0.00	\$ 13,861,570.57	\$ 9,382,056.58
\$ 2,727,502.02	\$ 14,277,417.69	\$0.00	\$ 14,277,417.69	\$ 9,663,518.28
\$ 2,727,502.02	\$ 14,705,740.22	\$0.00	\$ 14,705,740.22	\$ 9,953,423.83
Total			\$ 684,978,308.26	\$ 463,620,281.17

Life Cycle Cost Analysis Variables

Assumed Variables

Lake Level	534
TSR Elevation	731
Static Head	197
Pipe Diameter (in)	96
Friction Factor, C	120
Pressure Pipe Length (ft)	187605
Peaking Factor 1	1.4
PF 1 Duration (Mo)	4
Peaking Factor 2	0.8
PF 2 Duration (Mo)	8

Power Variables

Electricity Cost (kW-hr)	\$	0.05
Run Time (PF 1, hrs)		2920
Run Time (PF 2, hrs)		5840
Pumping Efficiency		75%

Financial Variables

Bond Interest Rate	4.50%
Bond Term (yrs)	25
Discount Rate	5%
Inflation Rate	3%

Construction Cost

\$/dia-in/ft	\$	9.50
Construction Cost	\$	171,095,760.00
Inflated Const. Cost (2021 Dollars)	\$	216,738,989.82

Average		
Year	Sequence	Surface Water Delivered (MGD)
2021	8	40
2022	9	40
2023	10	40
2024	11	40
2025	12	40
2026	13	40
2027	14	50
2028	15	60
2029	16	70
2030	17	80
2031	18	88
2032	19	96
2033	20	104
2034	21	110
2035	22	110
2036	23	110
2037	24	110
2038	25	110
2039	26	110
2040	27	110
2041	28	110
2042	29	110
2043	30	110
2044	31	110
2045	32	110
2046	33	110
2047	34	110
2048	35	110
2049	36	110
2050	37	110
2051	38	110
2052	39	110
2053	40	110
2054	41	110
2055	42	110
2056	43	110
2057	44	110
2058	45	110
2059	46	110
2060	47	110
2061	48	110
2062	49	110
2063	50	110
2064	51	110
2065	52	110
2066	53	110
2067	54	110
2068	55	110
2069	56	110
2070	57	110

70 MGD WTP

Expand to 140 MGD WTP

Expand to 210 MGD WTP

Expand to 280 MGD WTP

Total Cost				
Total Power	Inflated Power	Debt Service	Total Cost	Present Worth
Cost (\$)	Cost (\$)	(\$)	(\$)	(\$)
\$ 637,260.11	\$ 807,262.05	\$14,617,000.00	\$ 15,424,262.05	\$ 10,439,747.68
\$ 637,260.11	\$ 831,479.91	\$14,617,000.00	\$ 15,448,479.91	\$ 10,456,139.28
\$ 637,260.11	\$ 856,424.30	\$14,617,000.00	\$ 15,473,424.30	\$ 10,473,022.63
\$ 637,260.11	\$ 882,117.03	\$14,617,000.00	\$ 15,499,117.03	\$ 10,490,412.48
\$ 637,260.11	\$ 908,580.54	\$14,617,000.00	\$ 15,525,580.54	\$ 10,508,324.03
\$ 637,260.11	\$ 935,837.96	\$14,617,000.00	\$ 15,552,837.96	\$ 10,526,772.92
\$ 825,255.78	\$ 1,248,273.42	\$14,617,000.00	\$ 15,865,273.42	\$ 10,738,241.54
\$ 1,031,128.12	\$ 1,606,464.01	\$14,617,000.00	\$ 16,223,464.01	\$ 10,980,679.03
\$ 1,257,876.45	\$ 2,018,522.44	\$14,617,000.00	\$ 16,635,522.44	\$ 11,259,576.40
\$ 1,508,425.30	\$ 2,493,197.18	\$14,617,000.00	\$ 17,110,197.18	\$ 11,580,854.94
\$ 1,727,925.88	\$ 2,941,678.14	\$14,617,000.00	\$ 17,558,678.14	\$ 11,884,404.51
\$ 1,965,931.89	\$ 3,447,273.47	\$14,617,000.00	\$ 18,064,273.47	\$ 12,226,611.33
\$ 2,223,864.16	\$ 4,016,546.05	\$14,617,000.00	\$ 18,633,546.05	\$ 12,611,917.42
\$ 2,431,234.66	\$ 4,522,812.64	\$14,617,000.00	\$ 19,139,812.64	\$ 12,954,578.57
\$ 2,431,234.66	\$ 4,658,497.02	\$14,617,000.00	\$ 19,275,497.02	\$ 13,046,415.10
\$ 2,431,234.66	\$ 4,798,251.93	\$14,617,000.00	\$ 19,415,251.93	\$ 13,141,006.73
\$ 2,431,234.66	\$ 4,942,199.48	\$14,617,000.00	\$ 19,559,199.48	\$ 13,238,436.10
\$ 2,431,234.66	\$ 5,090,465.47	\$14,617,000.00	\$ 19,707,465.47	\$ 13,338,788.36
\$ 2,431,234.66	\$ 5,243,179.43	\$14,617,000.00	\$ 19,860,179.43	\$ 13,442,151.18
\$ 2,431,234.66	\$ 5,400,474.82	\$14,617,000.00	\$ 20,017,474.82	\$ 13,548,614.88
\$ 2,431,234.66	\$ 5,562,489.06	\$14,617,000.00	\$ 20,179,489.06	\$ 13,658,272.50
\$ 2,431,234.66	\$ 5,729,363.73	\$14,617,000.00	\$ 20,346,363.73	\$ 13,771,219.85
\$ 2,431,234.66	\$ 5,901,244.64	\$14,617,000.00	\$ 20,518,244.64	\$ 13,887,555.61
\$ 2,431,234.66	\$ 6,078,281.98	\$14,617,000.00	\$ 20,695,281.98	\$ 14,007,381.45
\$ 2,431,234.66	\$ 6,260,630.44	\$14,617,000.00	\$ 20,877,630.44	\$ 14,130,802.07
\$ 2,431,234.66	\$ 6,448,449.36	\$0.00	\$ 6,448,449.36	\$ 4,364,564.35
\$ 2,431,234.66	\$ 6,641,902.84	\$0.00	\$ 6,641,902.84	\$ 4,495,501.28
\$ 2,431,234.66	\$ 6,841,159.92	\$0.00	\$ 6,841,159.92	\$ 4,630,366.32
\$ 2,431,234.66	\$ 7,046,394.72	\$0.00	\$ 7,046,394.72	\$ 4,769,277.31
\$ 2,431,234.66	\$ 7,257,786.56	\$0.00	\$ 7,257,786.56	\$ 4,912,355.63
\$ 2,431,234.66	\$ 7,475,520.16	\$0.00	\$ 7,475,520.16	\$ 5,059,726.29
\$ 2,431,234.66	\$ 7,699,785.76	\$0.00	\$ 7,699,785.76	\$ 5,211,518.08
\$ 2,431,234.66	\$ 7,930,779.34	\$0.00	\$ 7,930,779.34	\$ 5,367,863.63
\$ 2,431,234.66	\$ 8,168,702.72	\$0.00	\$ 8,168,702.72	\$ 5,528,899.53
\$ 2,431,234.66	\$ 8,413,763.80	\$0.00	\$ 8,413,763.80	\$ 5,694,766.52
\$ 2,431,234.66	\$ 8,666,176.71	\$0.00	\$ 8,666,176.71	\$ 5,865,609.52
\$ 2,431,234.66	\$ 8,926,162.01	\$0.00	\$ 8,926,162.01	\$ 6,041,577.80
\$ 2,431,234.66	\$ 9,193,946.87	\$0.00	\$ 9,193,946.87	\$ 6,222,825.14
\$ 2,431,234.66	\$ 9,469,765.28	\$0.00	\$ 9,469,765.28	\$ 6,409,509.89
\$ 2,431,234.66	\$ 9,753,858.24	\$0.00	\$ 9,753,858.24	\$ 6,601,795.19
\$ 2,431,234.66	\$ 10,046,473.98	\$0.00	\$ 10,046,473.98	\$ 6,799,849.04
\$ 2,431,234.66	\$ 10,347,868.20	\$0.00	\$ 10,347,868.20	\$ 7,003,844.51
\$ 2,431,234.66	\$ 10,658,304.25	\$0.00	\$ 10,658,304.25	\$ 7,213,959.85
\$ 2,431,234.66	\$ 10,978,053.38	\$0.00	\$ 10,978,053.38	\$ 7,430,378.64
\$ 2,431,234.66	\$ 11,307,394.98	\$0.00	\$ 11,307,394.98	\$ 7,653,290.00
\$ 2,431,234.66	\$ 11,646,616.83	\$0.00	\$ 11,646,616.83	\$ 7,882,888.70
\$ 2,431,234.66	\$ 11,996,015.33	\$0.00	\$ 11,996,015.33	\$ 8,119,375.36
\$ 2,431,234.66	\$ 12,355,895.79	\$0.00	\$ 12,355,895.79	\$ 8,362,956.63
\$ 2,431,234.66	\$ 12,726,572.67	\$0.00	\$ 12,726,572.67	\$ 8,613,845.32
\$ 2,431,234.66	\$ 13,108,369.85	\$0.00	\$ 13,108,369.85	\$ 8,872,260.68
Total			\$ 687,712,266.69	\$ 465,470,731.85

Life Cycle Cost Analysis Variables		
Assumed Variables		
Lake Level		534
TSR Elevation		731
Static Head		197
Pipe Diameter (in)		102
Friction Factor, C		120
Pressure Pipe Length (ft)		187605
Peaking Factor 1		1.4
PF 1 Duration (Mo)		4
Peaking Factor 2		0.8
PF 2 Duration (Mo)		8
Power Variables		
Electricity Cost (kW-hr)	\$	0.05
Run Time (PF 1, hrs)		2920
Run Time (PF 2, hrs)		5840
Pumping Efficiency		75%
Financial Variables		
Bond Interest Rate		4.50%
Bond Term (yrs)		25
Discount Rate		5%
Inflation Rate		3%
Construction Cost		
\$/dia-in/ft	\$	10.00
Construction Cost	\$	191,357,100.00
Inflated Const. Cost (2021 Dollars)	\$	242,405,449.14

Average		
Year	Sequence	Surface Water Delivered (MGD)
70 MGD WTP	2021	8
	2022	9
	2023	10
	2024	11
	2025	12
Expand to 140 MGD WTP	2026	13
	2027	14
	2028	15
	2029	16
Expand to 210 MGD WTP	2030	17
	2031	18
	2032	19
	2033	20
	2034	21
Expand to 280 MGD WTP	2035	22
	2036	23
	2037	24
	2038	25
	2039	26
	2040	27
	2041	28
	2042	29
	2043	30
	2044	31
	2045	32
	2046	33
	2047	34
	2048	35
	2049	36
	2050	37
	2051	38
	2052	39
	2053	40
	2054	41
	2055	42
	2056	43
	2057	44
	2058	45
	2059	46
	2060	47
	2061	48
	2062	49
	2063	50
	2064	51
	2065	52
	2066	53
	2067	54
	2068	55
	2069	56
	2070	57

Total Cost				
Total Power	Inflated Power	Debt Service	Total Cost	Present Worth
Cost (\$)	Cost (\$)	(\$)	(\$)	(\$)
625,782.68	\$ 792,722.77	\$16,348,000.00	\$ 17,140,722.77	\$ 11,601,515.87
625,782.68	\$ 816,504.46	\$16,348,000.00	\$ 17,164,504.46	\$ 11,617,612.25
\$ 625,782.68	\$ 840,999.59	\$16,348,000.00	\$ 17,188,999.59	\$ 11,634,191.52
\$ 625,782.68	\$ 866,229.58	\$16,348,000.00	\$ 17,214,229.58	\$ 11,651,268.17
\$ 625,782.68	\$ 892,216.47	\$16,348,000.00	\$ 17,240,216.47	\$ 11,668,857.11
\$ 625,782.68	\$ 918,982.96	\$16,348,000.00	\$ 17,266,982.96	\$ 11,686,973.73
\$ 803,576.83	\$ 1,215,482.05	\$16,348,000.00	\$ 17,563,482.05	\$ 11,887,655.99
\$ 994,677.50	\$ 1,549,675.13	\$16,348,000.00	\$ 17,897,675.13	\$ 12,113,851.02
\$ 1,201,317.25	\$ 1,927,761.53	\$16,348,000.00	\$ 18,275,761.53	\$ 12,369,754.77
\$ 1,425,672.95	\$ 2,356,420.15	\$16,348,000.00	\$ 18,704,420.15	\$ 12,659,887.80
\$ 1,619,345.96	\$ 2,756,828.11	\$16,348,000.00	\$ 19,104,828.11	\$ 12,930,899.67
\$ 1,826,793.53	\$ 3,203,293.51	\$16,348,000.00	\$ 19,551,293.51	\$ 13,233,085.03
\$ 2,049,073.23	\$ 3,700,854.19	\$16,348,000.00	\$ 20,048,854.19	\$ 13,569,853.68
\$ 2,226,145.35	\$ 4,141,286.10	\$16,348,000.00	\$ 20,489,286.10	\$ 13,867,955.33
\$ 2,226,145.35	\$ 4,265,524.69	\$16,348,000.00	\$ 20,613,524.69	\$ 13,952,044.90
\$ 2,226,145.35	\$ 4,393,490.43	\$16,348,000.00	\$ 20,741,490.43	\$ 14,038,657.15
\$ 2,226,145.35	\$ 4,525,295.14	\$16,348,000.00	\$ 20,873,295.14	\$ 14,127,867.77
\$ 2,226,145.35	\$ 4,661,053.99	\$16,348,000.00	\$ 21,009,053.99	\$ 14,219,754.70
\$ 2,226,145.35	\$ 4,800,885.61	\$16,348,000.00	\$ 21,148,885.61	\$ 14,314,398.25
\$ 2,226,145.35	\$ 4,944,912.18	\$16,348,000.00	\$ 21,292,912.18	\$ 14,411,881.10
\$ 2,226,145.35	\$ 5,093,259.55	\$16,348,000.00	\$ 21,441,259.55	\$ 14,512,288.43
\$ 2,226,145.35	\$ 5,246,057.33	\$16,348,000.00	\$ 21,594,057.33	\$ 14,615,707.99
\$ 2,226,145.35	\$ 5,403,439.05	\$16,348,000.00	\$ 21,751,439.05	\$ 14,722,230.13
\$ 2,226,145.35	\$ 5,565,542.23	\$16,348,000.00	\$ 21,913,542.23	\$ 14,831,947.94
\$ 2,226,145.35	\$ 5,732,508.49	\$16,348,000.00	\$ 22,080,508.49	\$ 14,944,957.28
\$ 2,226,145.35	\$ 5,904,483.75	\$0.00	\$ 5,904,483.75	\$ 3,996,387.01
\$ 2,226,145.35	\$ 6,081,618.26	\$0.00	\$ 6,081,618.26	\$ 4,116,278.62
\$ 2,226,145.35	\$ 6,264,066.81	\$0.00	\$ 6,264,066.81	\$ 4,239,766.98
\$ 2,226,145.35	\$ 6,451,988.81	\$0.00	\$ 6,451,988.81	\$ 4,366,959.99
\$ 2,226,145.35	\$ 6,645,548.48	\$0.00	\$ 6,645,548.48	\$ 4,497,968.79
\$ 2,226,145.35	\$ 6,844,914.93	\$0.00	\$ 6,844,914.93	\$ 4,632,907.86
\$ 2,226,145.35	\$ 7,050,262.38	\$0.00	\$ 7,050,262.38	\$ 4,771,895.09
\$ 2,226,145.35	\$ 7,261,770.25	\$0.00	\$ 7,261,770.25	\$ 4,915,051.94
\$ 2,226,145.35	\$ 7,479,623.36	\$0.00	\$ 7,479,623.36	\$ 5,062,503.50
\$ 2,226,145.35	\$ 7,704,012.06	\$0.00	\$ 7,704,012.06	\$ 5,214,378.61
\$ 2,226,145.35	\$ 7,935,132.42	\$0.00	\$ 7,935,132.42	\$ 5,370,809.97
\$ 2,226,145.35	\$ 8,173,186.39	\$0.00	\$ 8,173,186.39	\$ 5,531,934.26
\$ 2,226,145.35	\$ 8,418,381.99	\$0.00	\$ 8,418,381.99	\$ 5,697,892.29
\$ 2,226,145.35	\$ 8,670,933.44	\$0.00	\$ 8,670,933.44	\$ 5,868,829.06
\$ 2,226,145.35	\$ 8,931,061.45	\$0.00	\$ 8,931,061.45	\$ 6,044,893.93
\$ 2,226,145.35	\$ 9,198,993.29	\$0.00	\$ 9,198,993.29	\$ 6,226,240.75
\$ 2,226,145.35	\$ 9,474,963.09	\$0.00	\$ 9,474,963.09	\$ 6,413,027.97
\$ 2,226,145.35	\$ 9,759,211.98	\$0.00	\$ 9,759,211.98	\$ 6,605,418.81
\$ 2,226,145.35	\$ 10,051,988.34	\$0.00	\$ 10,051,988.34	\$ 6,803,581.38
\$ 2,226,145.35	\$ 10,353,547.99	\$0.00	\$ 10,353,547.99	\$ 7,007,688.82
\$ 2,226,145.35	\$ 10,664,154.43	\$0.00	\$ 10,664,154.43	\$ 7,217,919.48
\$ 2,226,145.35	\$ 10,984,079.07	\$0.00	\$ 10,984,079.07	\$ 7,434,457.07
\$ 2,226,145.35	\$ 11,313,601.44	\$0.00	\$ 11,313,601.44	\$ 7,657,490.78
\$ 2,226,145.35	\$ 11,653,009.48	\$0.00	\$ 11,653,009.48	\$ 7,887,215.50
\$ 2,226,145.35	\$ 12,002,599.76	\$0.00	\$ 12,002,599.76	\$ 8,123,831.97
Total			\$ 704,584,358.96	\$ 476,890,428.02

Life Cycle Cost Analysis Variables

Assumed Variables

Lake Level	534
TSR Elevation	731
Static Head	197
Pipe Diameter (in)	108
Friction Factor, C	120
Pressure Pipe Length (ft)	187605
Peaking Factor 1	1.4
PF 1 Duration (Mo)	4
Peaking Factor 2	0.8
PF 2 Duration (Mo)	8

Power Variables

Electricity Cost (kW-hr)	\$	0.05
Run Time (PF 1, hrs)		2920
Run Time (PF 2, hrs)		5840
Pumping Efficiency		75%

Financial Variables

Bond Interest Rate	4.50%
Bond Term (yrs)	25
Discount Rate	5%
Inflation Rate	3%

Construction Cost

\$/dia-in/ft	\$	11.00
Construction Cost	\$	222,874,740.00
Inflated Const. Cost (2021 Dollars)	\$	282,331,052.53

Average		
Year	Sequence	Surface Water Delivered (MGD)
2021	8	40
2022	9	40
2023	10	40
2024	11	40
2025	12	40
2026	13	40
2027	14	50
2028	15	60
2029	16	70
2030	17	80
2031	18	88
2032	19	96
2033	20	104
2034	21	110
2035	22	110
2036	23	110
2037	24	110
2038	25	110
2039	26	110
2040	27	110
2041	28	110
2042	29	110
2043	30	110
2044	31	110
2045	32	110
2046	33	110
2047	34	110
2048	35	110
2049	36	110
2050	37	110
2051	38	110
2052	39	110
2053	40	110
2054	41	110
2055	42	110
2056	43	110
2057	44	110
2058	45	110
2059	46	110
2060	47	110
2061	48	110
2062	49	110
2063	50	110
2064	51	110
2065	52	110
2066	53	110
2067	54	110
2068	55	110
2069	56	110
2070	57	110

70 MGD WTP

Expand to 140 MGD WTP

Expand to 210 MGD WTP

Expand to 280 MGD WTP

Total Cost				
Total Power	Inflated Power	Debt Service	Total Cost	Present Worth
Cost (\$)	Cost (\$)	(\$)	(\$)	(\$)
617,662.89	\$ 782,436.87	\$19,040,000.00	\$ 19,822,436.87	\$ 13,416,605.53
617,662.89	\$ 805,909.98	\$19,040,000.00	\$ 19,845,909.98	\$ 13,432,493.05
\$ 617,662.89	\$ 830,087.28	\$19,040,000.00	\$ 19,870,087.28	\$ 13,448,857.20
\$ 617,662.89	\$ 854,989.90	\$19,040,000.00	\$ 19,894,989.90	\$ 13,465,712.27
\$ 617,662.89	\$ 880,639.59	\$19,040,000.00	\$ 19,920,639.59	\$ 13,483,072.99
\$ 617,662.89	\$ 907,058.78	\$19,040,000.00	\$ 19,947,058.78	\$ 13,500,954.54
\$ 788,239.91	\$ 1,192,283.58	\$19,040,000.00	\$ 20,232,283.58	\$ 13,694,005.91
\$ 968,890.27	\$ 1,509,499.47	\$19,040,000.00	\$ 20,549,499.47	\$ 13,908,710.11
\$ 1,161,304.07	\$ 1,863,552.12	\$19,040,000.00	\$ 20,903,552.12	\$ 14,148,346.88
\$ 1,367,129.25	\$ 2,259,656.35	\$19,040,000.00	\$ 21,299,656.35	\$ 14,416,445.82
\$ 1,542,530.40	\$ 2,626,054.74	\$19,040,000.00	\$ 21,666,054.74	\$ 14,664,438.67
\$ 1,728,359.19	\$ 3,030,688.30	\$19,040,000.00	\$ 22,070,688.30	\$ 14,938,310.59
\$ 1,925,416.25	\$ 3,477,515.92	\$19,040,000.00	\$ 22,517,515.92	\$ 15,240,741.11
\$ 2,081,053.57	\$ 3,871,372.67	\$19,040,000.00	\$ 22,911,372.67	\$ 15,507,318.86
\$ 2,081,053.57	\$ 3,987,513.85	\$19,040,000.00	\$ 23,027,513.85	\$ 15,585,927.78
\$ 2,081,053.57	\$ 4,107,139.26	\$19,040,000.00	\$ 23,147,139.26	\$ 15,666,894.97
\$ 2,081,053.57	\$ 4,230,353.44	\$19,040,000.00	\$ 23,270,353.44	\$ 15,750,291.18
\$ 2,081,053.57	\$ 4,357,264.04	\$19,040,000.00	\$ 23,397,264.04	\$ 15,836,189.27
\$ 2,081,053.57	\$ 4,487,981.96	\$19,040,000.00	\$ 23,527,981.96	\$ 15,924,664.30
\$ 2,081,053.57	\$ 4,622,621.42	\$19,040,000.00	\$ 23,662,621.42	\$ 16,015,793.59
\$ 2,081,053.57	\$ 4,761,300.07	\$19,040,000.00	\$ 23,801,300.07	\$ 16,109,656.75
\$ 2,081,053.57	\$ 4,904,139.07	\$19,040,000.00	\$ 23,944,139.07	\$ 16,206,335.81
\$ 2,081,053.57	\$ 5,051,263.24	\$19,040,000.00	\$ 24,091,263.24	\$ 16,305,915.24
\$ 2,081,053.57	\$ 5,202,801.14	\$19,040,000.00	\$ 24,242,801.14	\$ 16,408,482.06
\$ 2,081,053.57	\$ 5,358,885.17	\$19,040,000.00	\$ 24,398,885.17	\$ 16,514,125.87
\$ 2,081,053.57	\$ 5,519,651.73	\$0.00	\$ 5,519,651.73	\$ 3,735,917.55
\$ 2,081,053.57	\$ 5,685,241.28	\$0.00	\$ 5,685,241.28	\$ 3,847,995.08
\$ 2,081,053.57	\$ 5,855,798.52	\$0.00	\$ 5,855,798.52	\$ 3,963,434.93
\$ 2,081,053.57	\$ 6,031,472.47	\$0.00	\$ 6,031,472.47	\$ 4,082,337.98
\$ 2,081,053.57	\$ 6,212,416.65	\$0.00	\$ 6,212,416.65	\$ 4,204,808.12
\$ 2,081,053.57	\$ 6,398,789.15	\$0.00	\$ 6,398,789.15	\$ 4,330,952.36
\$ 2,081,053.57	\$ 6,590,752.82	\$0.00	\$ 6,590,752.82	\$ 4,460,880.93
\$ 2,081,053.57	\$ 6,788,475.40	\$0.00	\$ 6,788,475.40	\$ 4,594,707.36
\$ 2,081,053.57	\$ 6,992,129.67	\$0.00	\$ 6,992,129.67	\$ 4,732,548.58
\$ 2,081,053.57	\$ 7,201,893.56	\$0.00	\$ 7,201,893.56	\$ 4,874,525.04
\$ 2,081,053.57	\$ 7,417,950.36	\$0.00	\$ 7,417,950.36	\$ 5,020,760.79
\$ 2,081,053.57	\$ 7,640,488.87	\$0.00	\$ 7,640,488.87	\$ 5,171,383.62
\$ 2,081,053.57	\$ 7,869,703.54	\$0.00	\$ 7,869,703.54	\$ 5,326,525.12
\$ 2,081,053.57	\$ 8,105,794.65	\$0.00	\$ 8,105,794.65	\$ 5,486,320.88
\$ 2,081,053.57	\$ 8,348,968.49	\$0.00	\$ 8,348,968.49	\$ 5,650,910.50
\$ 2,081,053.57	\$ 8,599,437.54	\$0.00	\$ 8,599,437.54	\$ 5,820,437.82
\$ 2,081,053.57	\$ 8,857,420.67	\$0.00	\$ 8,857,420.67	\$ 5,995,050.95
\$ 2,081,053.57	\$ 9,123,143.29	\$0.00	\$ 9,123,143.29	\$ 6,174,902.48
\$ 2,081,053.57	\$ 9,396,837.59	\$0.00	\$ 9,396,837.59	\$ 6,360,149.56
\$ 2,081,053.57	\$ 9,678,742.71	\$0.00	\$ 9,678,742.71	\$ 6,550,954.04
\$ 2,081,053.57	\$ 9,969,104.99	\$0.00	\$ 9,969,104.99	\$ 6,747,482.66
\$ 2,081,053.57	\$ 10,268,178.14	\$0.00	\$ 10,268,178.14	\$ 6,949,907.14
\$ 2,081,053.57	\$ 10,576,223.49	\$0.00	\$ 10,576,223.49	\$ 7,158,404.36
\$ 2,081,053.57	\$ 10,893,510.19	\$0.00	\$ 10,893,510.19	\$ 7,373,156.49
\$ 2,081,053.57	\$ 11,220,315.50	\$0.00	\$ 11,220,315.50	\$ 7,594,351.18
Total			\$ 753,205,449.46	\$ 509,799,095.89

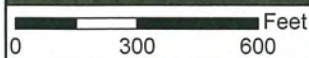
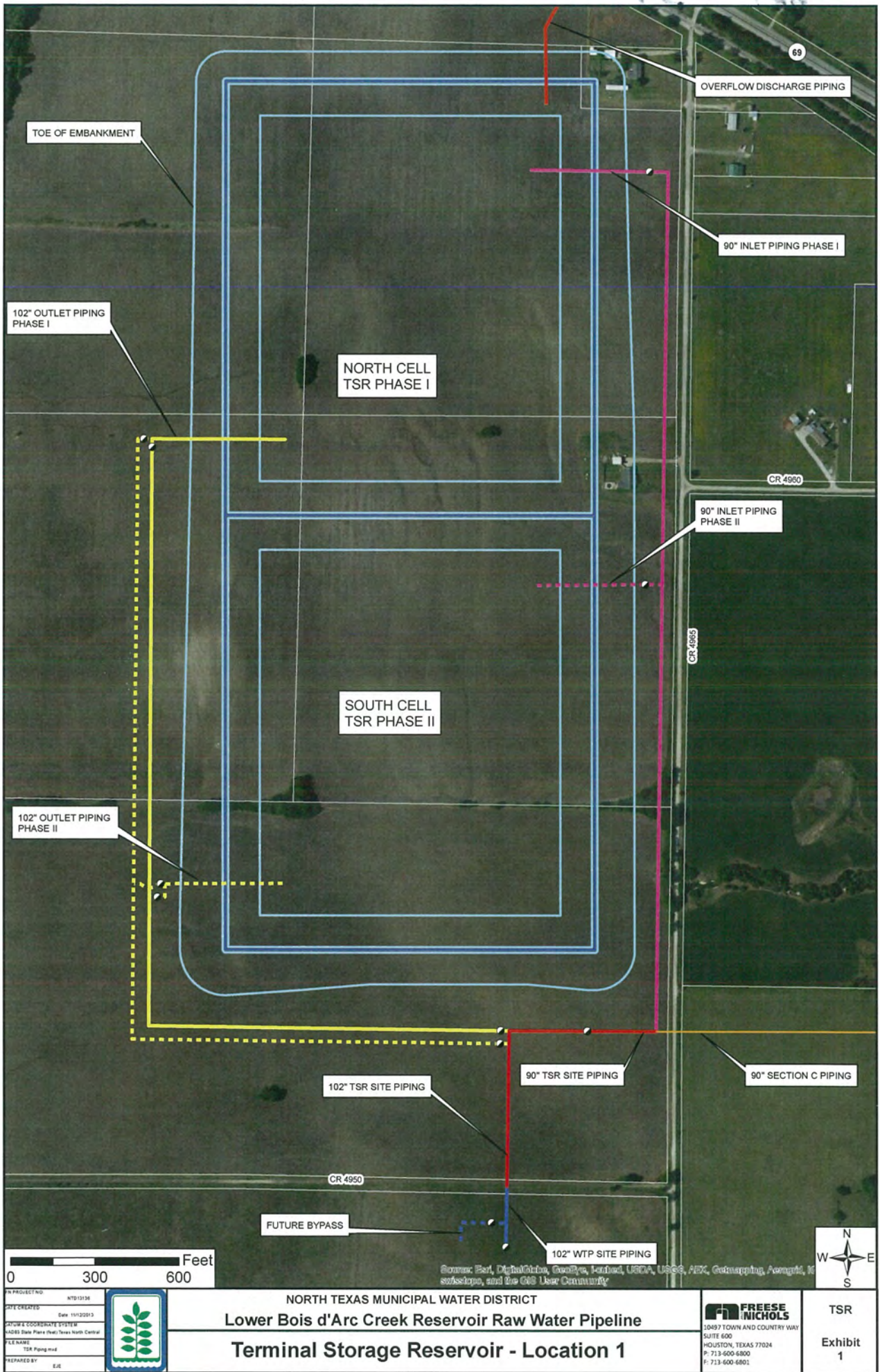

PROJECT NO.	NTD13136
DATE CREATED	Date: 10/12/2013
OWNER & COORDINATE SYSTEM	ADSS State Plane (NAD) Texas North Central
FILE NAME	TSR Piping.mxd
PREPARED BY	EJC



NORTH TEXAS MUNICIPAL WATER DISTRICT
Lower Bois d'Arc Creek Reservoir Raw Water Pipeline
Terminal Storage Reservoir - Location 1

FREESE NICHOLS
 10497 TOWN AND COUNTRY WAY
 SUITE 500
 HOUSTON, TEXAS 77024
 P: 713-600-6800
 F: 713-600-6801



TSR
 Exhibit
 1

10/12/2013 10:00 AM

CONFLICTS MAP

PART #54

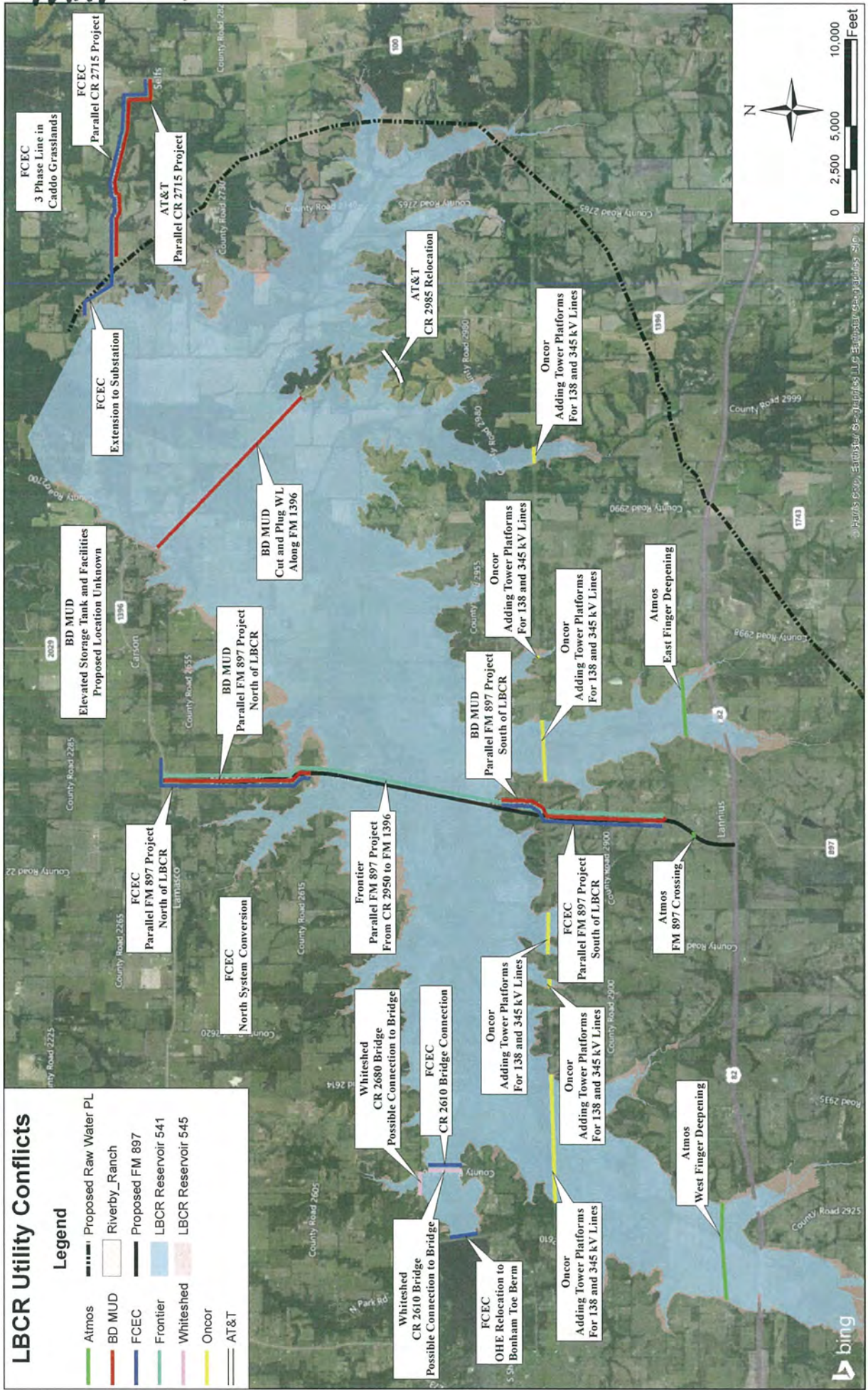

PART D
#54



Innovative approaches
Practical results
Outstanding service



LOWER BOIS D'ARC CREEK RESERVOIR FINAL DESIGN REPORT ←

Prepared for:



North Texas Municipal Water District

November 20, 2015

Prepared by:

FREESE AND NICHOLS, INC.
4055 International Plaza, Suite 200
Fort Worth, Texas 76109
817-735-7300

NTD13565



Innovative approaches
Practical results
Outstanding service

LOWER BOIS D'ARC CREEK RESERVOIR FINAL DESIGN REPORT

Prepared for:

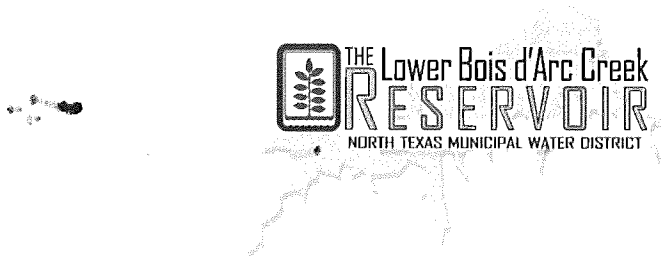

North Texas Municipal Water District

DRAFT

THIS DOCUMENT IS RELEASED FOR THE
PURPOSE OF INTERIM REVIEW UNDER THE
AUTHORITY OF JOHN L RUTLEDGE, P.E., TEXAS
NO. 65045 ON NOVEMBER 20, 2015. IT IS NOT
TO BE USED FOR CONSTRUCTION, BIDDING OR
PERMIT PURPOSES.

FREESE AND NICHOLS, INC.
TEXAS REGISTERED ENGINEERING FIRM F- 2144

Prepared by:

FREESE AND NICHOLS, INC.
4055 International Plaza, Suite 200
Fort Worth, Texas 76109
817-735-7300

NTD13565

TABLE OF CONTENTS

1.0	INTRODUCTION.....	1-1
1.1	Overall Project Description.....	1-3
1.2	Dam and Reservoir.....	1-3
1.3	Service Spillway, Intake, and Outlet Works.....	1-4
1.4	Lake Bonham Dam Modifications.....	1-5
2.0	FIELD AND LABORATORY INVESTIGATIONS.....	2-1
2.1	Summary of Field Investigation.....	2-1
2.1.1	Boring and Test Pit Locations.....	2-1
2.1.2	Drilling and Sampling of Borings.....	2-1
2.1.3	Excavation of Test Pits.....	2-4
2.1.4	Boring and Test Pit Logs.....	2-4
2.1.5	Piezometer Installation and Readings.....	2-4
2.1.6	In-situ Permeability (Packer) Testing.....	2-6
2.1.7	Geophysical Survey.....	2-7
2.2	Laboratory Investigation.....	2-8
3.0	GEOLOGY AND SUBSURFACE CONDITIONS.....	3-1
3.1	Geology.....	3-1
3.1.1	Physiographic Setting.....	3-1
3.1.2	Geologic Setting.....	3-1
3.1.3	Structure.....	3-4
3.1.4	Tectonic Faulting.....	3-4
3.2	Seismic Considerations.....	3-5
3.2.1	Seismicity.....	3-5
3.2.2	Liquefaction Potential.....	3-6
3.3	Site and Subsurface Conditions.....	3-6
3.3.1	Site Description.....	3-6
3.3.2	Subsurface Stratigraphy.....	3-1
3.4	Groundwater.....	3-3
4.0	CARE OF WATER AND CONSTRUCTION SEQUENCING.....	4-1
4.1	Diversion Phases.....	4-1
4.1.1	Phase 1 Conditions.....	4-1
4.1.2	Phase 2 – Closed Conduit Diversion.....	4-2
4.1.3	Phase 3 – Impoundment Phase.....	4-3

5.0	EMBANKMENT.....	5-1
5.1	General.....	5-1
5.2	Highly Plastic Clay Issues.....	5-2
5.3	Section Geometry.....	5-3
5.4	Foundation and Cutoff.....	5-1
5.5	Embankment Stability Analysis.....	5-4
5.5.1	Seepage Analysis.....	5-5
5.5.2	Slope Stability.....	5-7
5.5.3	Settlement.....	5-10
5.6	Seismic Considerations.....	5-14
5.6.1	Seismicity.....	5-14
5.6.2	Liquefaction.....	5-15
5.7	Internal Filter and Drainage.....	5-15
5.8	Soil Cement Configuration.....	5-17
5.9	Recommended Instrumentation.....	5-19
5.10	Summary of Embankment Configuration.....	5-20
6.0	SERVICE SPILLWAY.....	6-1
6.1	Background.....	6-1
6.2	Approach Walls.....	6-3
6.3	Crest Structure and Labyrinth Weir.....	6-5
6.3.1	Spillway Outlet Walls.....	6-6
6.3.2	Labyrinth Weir Walls.....	6-7
6.3.3	Abutment and Training Walls.....	6-7
6.4	Upper Chute Structure.....	6-7
6.5	Lower Chute and Stilling Basin Structure.....	6-8
6.6	Trash boom.....	6-10
6.7	Stop Logs and Trash Screens.....	6-11
7.0	INTAKE STRUCTURE AND CONDUITS.....	7-1
7.1	Background Information.....	7-1
7.2	Intake Tower.....	7-1
7.3	Screens and stop logs.....	7-4
7.4	Intake Access Bridge.....	7-6
7.5	Pump station Intake Conduit and Layout.....	7-7
8.0	EMERGENCY SPILLWAY.....	8-1
9.0	INSTRUMENTATION.....	9-1

9.1	Embankment.....	9-1
9.2	Internal Drainage System	9-2
9.3	Service Spillway.....	9-2
9.4	Intake Structure and Access Bridge	9-2
9.5	Additional Monitoring.....	9-3
9.6	Summary of Instrumentation.....	9-3
10.0	ELECTRICAL.....	10-1
10.1	Power.....	10-1
10.2	Lighting	10-2
10.3	Security/SCADA.....	10-2
11.0	LAKE BONHAM MODIFICATIONS.....	11-3
11.1	Embankment.....	11-4
11.1.1	Existing Conditions.....	11-4
11.1.2	Impact of Lower Bois d'Arc Creek Reservoir	11-4
11.1.3	Proposed Modifications.....	11-5
11.2	Service Spillway.....	11-6
11.2.1	Existing Conditions.....	11-6
11.2.2	Impact of Lower Bois d'Arc Creek Reservoir	11-6
11.2.3	Proposed Modifications.....	11-7
11.3	Emergency Spillway	11-8
11.3.1	Existing Conditions.....	11-8
11.3.2	Impact of Lower Bois d'Arc Creek Reservoir	11-8
11.3.3	Proposed Modifications.....	11-8
11.4	Outlet Works	11-10
11.4.1	Existing Conditions.....	11-10
11.4.2	Impact of Lower Bois d'Arc Creek Reservoir	11-11
11.4.3	Proposed Modifications.....	11-11
11.5	Dam Safety Inspections.....	11-11

Table of Figures

Figure 1-1: Location of Lower Bois d’Arc Creek Reservoir Project	1-2
Figure 2-1: Boring Locations Map	2-2
Figure 2-2: Piezometer Readings through September 2015.....	2-6
Figure 3-1: Geologic Map (Interpreted).....	3-3
Figure 3-2: Dam Geologic Profile (1 of 2).....	3-0
Figure 3-3: Dam Geologic Profile (2 of 2).....	3-1
Figure 3-4: SS Geologic Profile	3-2
Figure 5-1: Typical Section – Left End through Station 44+00.....	5-1
Figure 5-2: Typical Section – Station 54+00 through Station 107+60	5-2
Figure 5-3: Typical Section – Station 107+60 through Right End.....	5-3
Figure 6-1: Isometric View of the Service Spillway Approach Walls and Crest	6-4
Figure 6-2: Isometric View of the Service Spillway Lower Chute and Stilling Basin	6-4
Figure 7-1: Isometric View of the Intake Tower and Bridge	7-2
Figure 11-1: Location Map of Lake Bonham Dam.....	11-3
Figure 11-2: Emergency Spillway Modifications	11-10

Table of Tables

Table 2-1: Schedule of Piezometers.....	2-5
Table 2-2: Packer Test Summary.....	2-6
Table 3-1: Generalized Stratigraphy – Left Terrace	3-3
Table 3-2: Generalized Stratigraphy – Valley Section.....	3-3
Table 3-3: Generalized Stratigraphy – Right Terrace and Service Spillway Centerline	3-3
Table 4-1: Design Inflows and Peak Elevations for the Lower Bois d’Arc Creek Reservoir Phase I Conditions.....	4-2
Table 4-2: Design Inflows and Peak Elevations for the Lower Bois d’Arc Creek Reservoir (Closed Conduit Diversion)	4-3
Table 4-3: Peak Design Flood Elevation, with Early Impoundment at Elevation 511.0.....	4-4
Table 5-1: Steady State Seepage Summary	5-6
Table 5-2: Slope Stability Requirements.....	5-9
Table 5-3: Slope Stability Summary	5-9
Table 5-4: Valley Section Settlement Summary for Preliminary Design Analysis.....	5-14
Table 5-5: Filter and Drain Gradation Analysis Results.....	5-16
Table 6-1: Spillway Crest Loads.....	6-5
Table 6-2: Stilling Basin Design Criteria	6-9
Table 11-1: Hydrologic Model Results	11-7

APPENDICES

- Appendix A References
- Appendix B Geotechnical Figures
- Appendix C Structural Calculations (Not Included)

1.0 INTRODUCTION

Lower Bois d'Arc Creek Reservoir is a proposed reservoir on Lower Bois d'Arc Creek, a tributary of the Red River. Figure 1-1: shows the location of the project, which is in Fannin County in North-Central Texas, and the service area of the North Texas Municipal Water District (NTMWD). A reservoir at this site (then called the Bonham Reservoir) was included in the Red River Compact (Red River Compact Commission, 1979). The project has been studied previously for the Red River Authority and the NTMWD (Freese and Nichols, 1984 and 1996) and was recommended as a water supply for the NTMWD in the 2001 and 2006 Region C Water Plans (Freese and Nichols et al., 2001 and 2006) and the 2002 Texas State Water Plan (Texas Water Development Board, 2002) and 2007 Texas State Water Plan (Texas Water Development Board, 2006). The Conceptual Design was developed as part of the water right permit application (Freese and Nichols, 2006). The Preliminary Design was developed and described in *Lower Bois d'Arc Creek Reservoir – Preliminary Design Report*, October, 2014, referred to in this report as the Preliminary Design Report.

The project will be used as municipal water supply for customers of NTMWD in North Central Texas and Fannin County. Most of the water used by NTMWD is expected to be transported via pipeline to a new treatment plant located near the City of Leonard in southwestern Fannin County.

Freese and Nichols completed the Preliminary Design of the dam, spillways, and intake structure, including an extensive geotechnical field exploration program in 2014 and subsequently was authorized to complete the final design of the structure. The Geotechnical Analysis Report and full Geotechnical Data Reports for the exploration program have been developed separately and are referenced within this document and are considered to be companion documents for appropriate reviews and documentation. This report includes a summary of the geotechnical and geologic analyses performed to date. The companion reports should be reviewed for more detail. This report, in general, covers the final design for the dam, spillways, and intake structures as well as the design of improvements needed to Lake Bonham Dam since the Lower Bois d'Arc

Creek Reservoir will back water up onto the toe of that dam. The hydrologic and hydraulic analysis to develop the design storm for the dam and spillways was finalized for the Preliminary Design Report and was reviewed and approved by regulatory agencies and are not repeated in this report. Another companion document is the set of Contract Drawings issued for Regulatory Review. This document, generally referred to as the Contract Drawings, and particular drawings within it are referenced within this report.

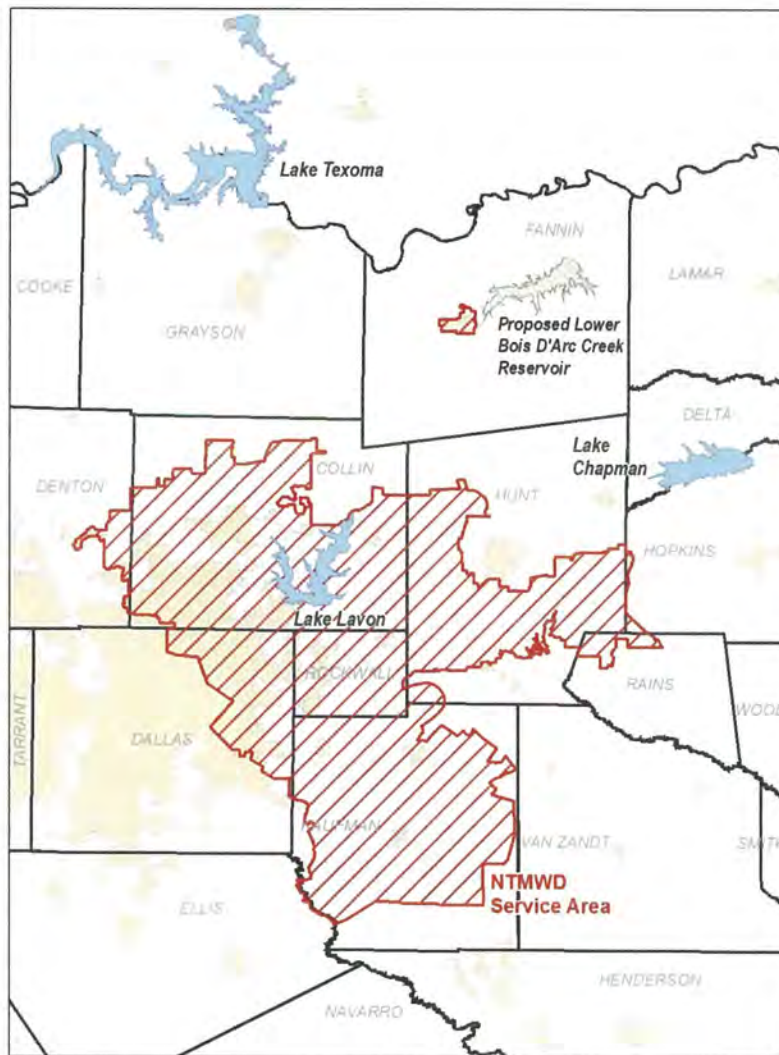

Figure 1-1: Location of Lower Bois d'Arc Creek Reservoir Project

1.1 OVERALL PROJECT DESCRIPTION

The proposed Lower Bois d'Arc Creek Reservoir Dam will be located in Fannin County in the Red River Basin, approximately 15 miles northeast of the City of Bonham. Figure 1.2 is a vicinity map of the proposed reservoir. The reservoir is located upstream of the Bois d'Arc Unit of the Caddo National Grasslands.

The drainage area of the proposed reservoir is approximately 327 square miles, of which 29.6 square miles are above Lake Bonham which is upstream of the Lower Bois d'Arc Creek Reservoir on Timber Creek. At its full conservation elevation of 534 feet mean seal level (msl), the reservoir is expected to cover 16,500 acres, store 367,600 acre-feet of water and be approximately 70 feet deep at its deepest point.

1.2 DAM AND RESERVOIR

Lower Bois d'Arc Creek Reservoir Dam will be constructed as a zoned earthen embankment. The configuration of the embankment is described in Chapter 5.0 and is also shown in detail in Section B of the Contract Drawings. The dam will be about 11,200 feet in length and will have a maximum height of about 90 feet. The design top elevation of the embankment will be 553.0 feet-msl, with varying amounts of overbuild to allow for settlement after construction. A flex base roadway will be provided on top of most of the embankment with portions topped with asphalt paving. The embankment will provide 19 feet of freeboard above the conservation pool of Lower Bois d'Arc Creek Reservoir, at elevation 534.0 feet-msl, and more than three feet of freeboard above the Probable Maximum Flood (PMF) elevation of 550.0 feet-msl. The upstream and downstream side slopes will be 3.5 horizontal to one vertical (3.5H:1V). All fill for the embankment is expected to come from required excavations of the spillways and from borrow pits located in the reservoir. Soil cement will be placed on the upstream slope for wave and erosion protection and a grass cover will be placed on the downstream slope.

In accordance with the criteria set forth in 30 Texas Administrative Code (TAC) §299.13 (Size Classification Criteria) and §299.14 (Hazard Classification Criteria), the proposed Lower Bois d'Arc Creek Reservoir Dam would be classified as a large, high-hazard dam. 30 §299.15 indicates that

the appropriate design storm for the dam is the PMF. The Preliminary Design Report (2014) described the design storm analysis for the project, and the details are not repeated in this report. The peak reservoir elevation during the PMF is 550.0 feet-msl and 540.0 for the 100 year flood. The *Hydrologic and Hydraulic Guidelines for Dams in Texas* from the Texas Commission on Environmental Quality (TCEQ) was used to estimate the design flood.

Summaries of the geotechnical exploration and lab testing are priorities in Chapter 2 and detail descriptions are provided in the companion documents *Geotechnical Data report, Volumes 1 and 2*. Summaries of the geologic conditions at the site are provided in chapter 3 with more detail in the *Geotechnical Analysis Report*, a separate companion report.

Constructability issues related to sequencing of the embankment, slurry trench, intake and spillway components of the project are discussed in Chapter 4.

An extensive instrumentation and monitoring program is planned for the embankment and is described in Chapter 9, Instrumentation.

1.3 SERVICE SPILLWAY, INTAKE, AND OUTLET WORKS

The service spillway will be located near the right (east) abutment of the dam. The spillway will consist of a 100-foot wide approach channel; a 60-foot wide, 3 cycle uncontrolled concrete labyrinth weir, a 600-foot long chute; a hydraulic jump stilling basin; and a 60-foot wide outlet channel. The crest of the spillway will be at elevation 534.0 feet-msl and the spillway will have a discharge capacity of 26,500 cfs at the maximum design water surface, elevation of 550.0 feet-msl. The spillway structure will extend approximately 780 feet downstream from the centerline of the dam to the downstream edge of the stilling basin. A hydraulic jump stilling basin, with two rows of baffle blocks is intended to serve as energy dissipation for the spillway. The stilling basin will be at elevation 460.0 feet-msl and it will be 125 feet long. Spillway discharges will be conveyed to Bois d'Arc Creek by a discharge channel approximately 2,500 feet long with a 60-foot bottom width. The spillway configuration is described in Chapter 6 and was developed with a physical model study performed by the Utah Water Resources Laboratory in Logan, Utah. A copy of their report was included in the Preliminary Design Report (2014).

Required environmental low-flow releases will be made through a 30-inch diameter low-flow outlet that will be valved off of the main intake conduits in the pump station. Larger releases required for environmental flows will be released through four large sluice gates located on either side of the labyrinth spillway crest. The Outlet Works are described in Chapter 6, Service Spillway and Outlet Works.

The intake for the pump station will include a multiple-level intake tower in the reservoir connected to two 78-inch conduits encased in reinforced concrete through the embankment. The intake tower and conduits are described in Chapter 7. The connection to the pump station and the pump station itself will be presented in a separate report.

An emergency spillway will be located in the right (east) abutment of the dam. The spillway is designed as a 1,500-foot wide uncontrolled broad crested earthen channel with the crest elevation at 540 feet-msl. This elevation was selected to contain the 100-year storm such that no flow passes through the emergency spillway during this event. The Emergency Spillway is described in Chapter 8.

An extensive instrumentation and monitoring program is planned for the service spillway and is described in Chapter 9, Instrumentation.

1.4 LAKE BONHAM DAM MODIFICATIONS

Lake Bonham is a 900 acre lake with a 52-foot high dam located 5.7 miles north-northeast of the City of Bonham. When full, the new Lower Bois d'Arc Creek Reservoir will impound water on the lower portions of the downstream slope of Lake Bonham Dam's embankment and submerge portions of the service spillway outlet conduit. Modifications to mitigate these impacts will include an expansion of the existing pilot channel in the emergency spillway, the placement of a berm and erosion protection on the downstream toe of the embankment and the installation of a wall at the downstream end of the spillway conduit to allow for the conduit to be drained for inspection. The improvements will have a net increase in discharge capacity for all flood levels at the lake. This is described in Chapter 11.

2.0 FIELD AND LABORATORY INVESTIGATIONS

This chapter provides a general summary of the field and laboratory portions of the geotechnical investigation for the Project. The results of the study are provided in the Geotechnical Investigation Report: Geotechnical Data Summary, Volumes 1 and 2. A summary of the analyses for the project are provided in the Geotechnical Investigation Report: Analysis Summary, Volume 3. All three of these volumes are dated November 2015. Selected data and figures have been included in this report, but refer to the individual volumes for the entire data set.

2.1 SUMMARY OF FIELD INVESTIGATION

2.1.1 Boring and Test Pit Locations

The geotechnical investigation included the drilling of a total 190 borings and the excavation of 16 test pits. Of these, 31 borings and 16 test pits were performed and sampled since the submission of the Preliminary Design Report in 2015. These additional locations (Phase 2) are summarized in the Geotechnical Investigation Report: Geotechnical Data Summary, Volume 2, while the previous borings and test pit logs from Phase 1 are summarized in Volume 1.

The location of all of the borings and test pits for both Phase 1 and 2 are provided on the Boring Location Map in Appendix B. Figure 2.1 provides an overview of the site and Sheets 1 to 11 provide views of the boring locations at a smaller engineering scale.

2.1.2 Drilling and Sampling of Borings

Don D. James, P.G. (FNI) supervised all field activities. Logging of the borings was performed by Mr. James, Mark Ickert, P.E., Micah Hargrave, P.E., Holly Saez, E.I.T., and Fred Ma, E.I.T., all of FNI. Drilling and sampling was conducted using CME-75 truck-mounted drilling rigs provided and staffed by Texplor of Dallas, Inc. The borings were advanced to the underlying rock using hollow-stem augers, with continuous-flight augers occasionally used for shallow boreholes. Sampling of soil material was achieved using push and direct drive techniques both with and without rotary wash, depending on the conditions encountered. Rotary wash techniques were used in all cases where core samples were collected. Each boring (except those converted into piezometers) was

backfilled at completion using a cement-bentonite grout mixture that was pressure-tremied from the bottom of the hole to the ground surface. The following lists the types of sampling techniques used for this exploration.

- Relatively undisturbed samples of cohesive soils were collected by pushing a seamless, steel tube sampler into the soil (based upon ASTM D 1587). After a tube was recovered, the sample was extruded in the field, examined, and logged. During logging, an estimate of the sample consistency was obtained using a hand penetrometer. The penetrometer reading is recorded at a corresponding depth on the boring logs.
- Selected samples were collected by driving a split-spoon sampler during the Standard Penetration Test (SPT) (based upon ASTM D 1586). The logger records the number of blows required to drive the sampler over three successive 6-inch increments. The first 6 inches is the seating drive. The number of blows required to drive the sampler the last two 6-inch increments is the penetration in blows per foot. When resistance is high, the number of inches of penetration for 50 blows of the hammer is recorded.
- Rock and rock-like materials in approximately half of the borings were evaluated in-place using the Texas Department of Transportation (TxDOT) Texas Cone Penetration (TCP) test. The TCP involves driving a steel cone into the material using a free-falling hammer (based upon Method TEX 132-E). During the test, the logger records either the number of blows producing 12 inches of penetration, or the total inches of penetration due to two successive increments of 50 blows (100 blows total).
- Rock was cored in approximately half of the borings using an NX-size, double tube core barrel with a carbide bit. The total length of the recovered sample was recorded as a percentage of the total run length. The total length of all the pieces greater than four inches in length was also recorded as a percentage of the total sample length, reported as the rock quality designation (RQD). Core breaks obviously caused by the drilling process were counted as a continuous piece. Breaks that were not easily distinguished as being a result of the drilling process were considered natural.

The depths at which the soil and rock samples were collected are indicated on the boring logs. The results of the various penetration tests, as well as the rock core recovery and RQD, are reported on the boring logs at the corresponding depth. After logging, moisture sensitive samples were sealed in a plastic bag, and the samples were then placed in a sample box for transport.

2.1.3 Excavation of Test Pits

The Construction Manager at Risk (CMAR) worked with FNI to select test pit locations that provided coverage of areas in the proposed borrow areas. The test pits were excavated in the field by CMAR team member Archer Western, Inc. using a Link-Belt 350X4 Excavator. Tony Bosecker, P.E. and Micah Hargrave, P.E. (FNI) observed and logged the field activities for the test pits. The test pits were excavated to a specified depth and soil material observations were made in the field.

2.1.4 Boring and Test Pit Logs

A log of each boring and test pit was developed in the field. Refer to Volumes 1 and 2 of the Geotechnical Investigation Report for a complete set of the logs. The logs indicate material type, depth, and other details for each boring. Soil and rock descriptions presented on the boring logs resulted from a combination of the field descriptions, laboratory test data and a project engineer's review. Stratigraphy lines correspond to the approximate boundary between strata, but note the in-situ subsurface transition can be, and is often, gradual.

2.1.5 Piezometer Installation and Readings

Thirteen (13) open-standpipe piezometers were installed at various boring locations, as noted in . The piezometers were constructed with 2-inch diameter, Schedule 40 PVC pipe. The subsurface data from the borings were used to develop screen depths for the piezometers. Prior to piezometer installation, the existing boring was backfilled with cement-bentonite grout, and a new hole was drilled near the existing boring location to a depth determined in the field that would place the screen within the desired formation.

Table 2-1: Schedule of Piezometers

Associated Boring No.	Screened Formation	Top of Casing Elevation	Screen Tip Depth	Screen Length
B-14	Ector Chalk Limestone	533.9 feet-msl	120 feet	20 feet
B-23	Terrace Deposits	530.4 feet-msl	56 feet	20 feet
B-31	Eagle Ford Shale	488.1 feet-msl	89 feet	15 feet
B-34	Alluvial Deposits	478.8 feet-msl	32 feet	10 feet
B-44	Alluvial Deposits	480.2 feet-msl	34 feet	15 feet
B-45	Shale/Sandstone	480.0 feet-msl	120 feet	30 feet
B-46	Alluvial Deposits	480.5 feet-msl	32 feet	15 feet
B-53	Alluvial Deposits	480.8 feet-msl	30 feet	15 feet
B-63	Alluvial Deposits	483.0 feet-msl	25 feet	15 feet
B-66	Alluvial Deposits/Bonham Contact	490.5 feet-msl	25 feet	15 feet
B-72	Terrace Deposits/Bonham Contact	489.6 feet-msl	20 feet	10 feet
B-73	Terrace Deposits/Bonham Contact	489.6 feet-msl	23 feet	15 feet
SS-07	Bonham/Ector Chalk Contact	551.1 feet-msl	100 feet	70 feet

Upon installation of the screen and riser pipe, silica filter sand (16/30) was placed around the pipe to a minimum elevation approximately 1-foot above the top of the screen. Hydrated bentonite pellets were then placed above the sand to create a seal above the piezometer screen and sand filter. Additional hydrated bentonite pellets or cement-bentonite grout was then placed around the remaining riser section to an approximate depth of 2 to 3 feet below ground surface. Concrete was then placed above the bentonite pellets/grout and tied in to the 4-foot by 4-foot concrete pad surrounding the riser. Surface completions for the piezometers include a locking j-plug at the top of the riser and a 5-inch by 5-inch steel pipe housing surrounding the upper 5 feet of the riser. The top of the riser is typically about 2 feet above existing ground surface.

Piezometer readings are shown on Figure 2.2. Refer to Volume 3 of the Geotechnical Investigation Report for analysis of the readings through September 2015.

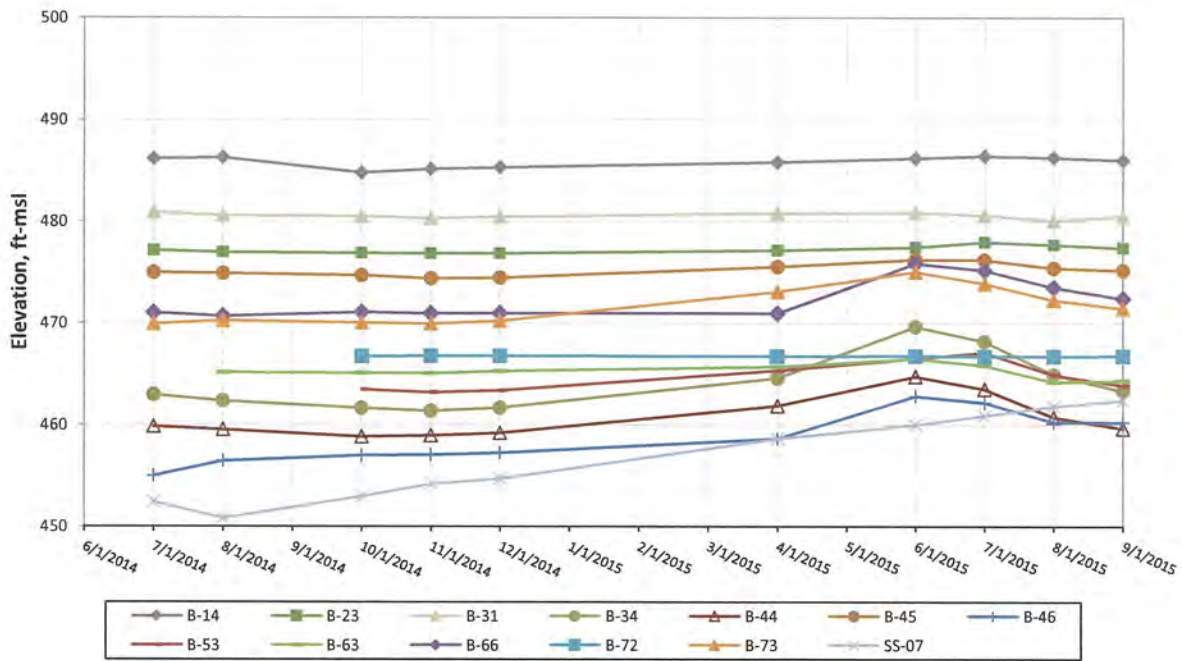

Figure 2-2: Piezometer Readings through September 2015

2.1.6 In-situ Permeability (Packer) Testing

Thirty-three (33) in-situ permeability (packer) tests were performed within twenty-eight (28) borings at various depths, as noted in , to test the transmissivity of the rock formation.

Table 2-2: Packer Test Summary

Boring No.	Date	Depth to Tip of Packer	Result
B-03	3/19/2014	35 feet	No Take
B-11	3/28/2014	65 feet	No Take
B-18	4/18/2014	65 feet	No Take
B-28	4/14/2014	39 feet	No Take
B-29	4/14/2014	39 feet	No Take
B-31	4/17/2014	25 feet	No Take
B-44	4/11/2014	38 feet	No Take
B-45	4/10/2014	38.5 feet	No Take
B-46	4/16/2014	39 feet	No Take
B-52	4/2/2014	40 feet	No Take
B-53	4/2/2014	35 feet	No Take
B-54	4/1/2014	35 feet	No Take
B-65	3/6/2014	30 feet	No Take
B-67	2/20/2014	45 feet	1.16 gpm

Boring No.	Date	Depth to Tip of Packer	Result
B-67	2/20/2014	50 feet	0.01 gpm
B-68	2/21/2014	50 feet	No Take
B-69	2/24/2014	30 feet	No Take
B-75	1/20/2015	28 feet	No Take
B-76	1/20/2015	25 feet	1.30 gpm
B-76	1/20/2015	35 feet	No Take
B-77	1/21/2015	28 feet	0.57 gpm
B-77	1/21/2015	38 feet	No Take
B-78	1/28/2015	27 feet	No Take
B-79	1/27/2015	25 feet	No Take
B-83	1/21/2015	25 feet	No Take
SS-01	2/20/2015	32 feet	0.01 gpm
SS-01	2/20/2015	37 feet	No Take
SS-02	2/19/2015	32 feet	0.005 gpm
SS-02	2/19/2015	37 feet	No Take
SS-03	2/5/2015	30 feet	No Take
SS-04	2/5/2015	35 feet	No Take
SS-05	2/4/2015	30 feet	No Take
SS-07	2/26/2014	40 feet	No Take

The test was performed with one bladder, at the depth indicated, to the bottom of the borehole. The details of each packer test are contained in Volumes 1 and 2 of the Geotechnical Investigation Report.

2.1.7 Geophysical Survey

As part of the field investigation, borings were drilled along the right abutment of the proposed dam. The results indicated varied subsurface strata from the proposed upstream toe to the proposed downstream toe. Specifically, the borings along the abutment indicated clay over shale at the proposed upstream toe of the embankment, approximately 18 feet of sand over clay and shale at the proposed centerline and about 40 feet of sand over shale at the proposed downstream toe of the embankment. In addition, borings were drilled at the proposed service spillway (right abutment) and at the proposed emergency spillway, located about 1,000 feet right (east) of the service spillway. Some of the planned borings were not allowed due to environmental permitting issues that are still being resolved.

Due to the varied subsurface strata along the right abutment and concerns with seepage through the area between the service spillway and the emergency spillway, a 2-D geophysical exploration survey was performed by Gehrig, Inc. to supplement the borings. The geophysical data assisted in: (1) defining the cutoff trench limits along the right abutment and; (2) providing a subsurface profile for the seepage analysis between the two spillways. The complete geophysical exploration report is provided in Volume 1 of the Geotechnical Investigation Report.

2.2 LABORATORY INVESTIGATION

Selected laboratory testing was performed for both the Phase 1 and Phase 2 borings. The results of these tests are summarized in Geotechnical Investigation Report: Geotechnical Data Summary, Volumes 1 and 2. Laboratory testing was performed by either Gorrondona & Associates, Inc. in their Fort Worth, Texas laboratory (for most routine classification and strength testing, dispersion, standard proctor testing, and moisture-density), or by TRI Environmental, Inc. in their Austin, Texas laboratory (for triaxial and direct shear testing, consolidation testing, and related classification testing).

Testing was generally performed on individual samples collected during the field exploration. However, samples from the borrow borings were selectively combined to establish the likely behavior of the excavated and mixed borrow materials. Testing was performed to allow for material classification (according to the Unified Soil Classification System, ASTM D 2487) and to evaluate various engineering properties of the materials. The laboratory testing program included the following:

- Atterberg Limits, ASTM D4318, "Standard Test Methods for Liquid Limit, Plastic Limit, and Plasticity Index of Soils."
- Consolidation, ASTM D2435, "Standard Test Methods for One-Dimensional Consolidation Properties of Soils Using Incremental Loading."
- Consolidated-Undrained Triaxial Shear Strength, ASTM D4767, "Standard Test Method for Consolidated Undrained Triaxial Compression Test for Cohesive Soils." This test was performed on remolded and undisturbed samples.

- Crumb Dispersion, ASTM D6572, “Standard Test Methods for Determining Dispersive Characteristics of Clayey Soils by the Crumb Test.”
- Direct Shear Strength, ASTM D5607, “Standard Test Method for Performing Laboratory Direct Shear Strength Tests of Rock Specimens under Constant Normal Force.” This test was performed on remolded and undisturbed samples.
- Dry Density Determinations as outlined in the sample preparation procedures of ASTM D2166, “Standard Test Method for Unconfined Compressive Strength of Cohesive Soil.”
- Hydraulic Conductivity, ASTM D5084, “Standard Test Methods for Measurement of Hydraulic Conductivity of Saturated Porous Materials Using a Flexible Wall Permeameter.”
- Moisture Content Tests, ASTM D2216, “Standard Test Method for Laboratory Determination of Water (Moisture) Content of Soil and Rock by Mass.”
- Particle Size Analysis/Gradation, ASTM D421, “Standard Practice for Dry Preparation of Soil Samples for Particle-Size Analysis and Determination of Soil Constants.”
- Percent Passing a Number 200 Sieve, ASTM D1140, “Standard Test Methods for Amount of Material in Soils Finer than the No. 200 (75- μ m) Sieve.”
- Specific Gravity, ASTM D854, “Standard Test Methods for Specific Gravity of Soil Solids by Water Pycnometer.”
- Standard Proctor Test, ASTM D698, “Standard Test Methods for Laboratory Compaction Characteristics of Soil using Standard Effort.”
- Swell Tests, ASTM D4546, “Standard Test Methods for One-Dimensional Swell or Collapse of Soils.”
- Unconfined Compressive Strength of Soil, ASTM D2166, “Standard Test Method for Unconfined Compressive Strength of Cohesive Soil.” This test was performed on undisturbed samples.
- Unconfined Compressive Strength of Rock, ASTM D2938, “Standard Test Method for Unconfined Compressive Strength of Intact Rock Core Specimens.” This test was performed on undisturbed samples.
- Unconsolidated-Undrained Triaxial Shear Strength, ASTM D2850, “Standard Test Method for Unconsolidated-Undrained Triaxial Compression Test on Cohesive Soils.” This test was performed on remolded and undisturbed samples.

The results of the tests are reported in on each boring log and on individual laboratory test reports in Geotechnical Investigation Report: Geotechnical Data Summary, Volumes 1 and 2.

3.0 GEOLOGY AND SUBSURFACE CONDITIONS

The following section provides a summary of the physiographic and geologic setting, and faulting for the project, and the seismic analysis. Additional detail and supporting documentation for these discussions are provided in the Geotechnical Investigation Report: Analysis Summary, Volume 3.

3.1 GEOLOGY

3.1.1 Physiographic Setting

The Lower Bois d'Arc Creek Reservoir site is located within the Blackland Prairies portion of the Gulf Coastal Plain physiographic province of North Central Texas. The United States Department of Agriculture's Natural Resource Conservation Commission identifies 12 soil classifications across the general footprint of the dam structure ranging from low infiltrating clay in the lowland floodplain bound by higher infiltrating sandy clay, clayey sands and sands located along the elevated end portions of the footprint to the east and west.

3.1.2 Geologic Setting

The Bois d'Arc and Honey Grove Creek tributary processes to the Red River have entrenched into a series of marine formations deposited during the late Cretaceous-Gulfian phase. The formation deposition and structure during this period resulted in a nearly complete series of marine deposits that gently dip gulfward and outcrop at the site (becomes younger gulfward). In geologically recent time (Quaternary), the Red River has episodically left terrace deposits on the higher drainage flanks of the once elevated landscape, and stream gradients have flattened enough to allow the floodplain to fill with alluvium comprised mostly of fines. According to the Texas Bureau of Economic Geology (BEG) Geologic Atlas of Texas, Texarkana Sheet, 1966 (revised 1979) and Sherman Sheet, 1967 (revised 1991) the primary geologic formations and alluvial deposits at the site are as follows.

- Quaternary Age Alluvium (Qal) comprising floodplain and channel deposits that consist of sand, silt, clay and gravel. The subsequent scour, and alluviation of both Honey Grove Creek and Bois d'Arc Creek, and fluvial backwash process of the Red

River have aggraded 30 to 40 plus feet of thickness of Quaternary alluvial soils within the current floodplain. This process along the Red River drainage system includes low terrace deposits not readily distinguishable on high altitude aerial photographs. They have a top surface 5 to 11 feet above the floodplain.

- Quaternary Age Terrace Deposits (Qt) are flood deposits from the fluvial processes of the Red River related to North American glacial and interglacial outwash sequences in combination with the evolving Bois d'Arc Creek when the general landscape was higher and was being eroded down to its current position. This erosion occurred episodically depositing lag deposits along contemporary flood margins of the creek flanks including:
 - Qt 4 terrace deposits consist of gravel, sand, and silt. The basal gravel grades upward to sand and silt, tan and gray, surface smooth on large outcrops, generally dissected with exposed bedrock at edges, and locally sheet washed at the head of gullies with a maximum thickness 30 feet, a top surface of 110 ± 10 feet above floodplain (Kansan). The Qt 4 soils were deposited first and mapped along the highest flanks to the east and west of the basin;
 - Qt 2 terrace deposits consist of gravel, sand, silt, some silty clay. The basal gravel is well sorted, cross-bedded, grades upward into well-bedded sand and silt with some thin beds of silty clay. It is mostly red to reddish tan, surface smooth, not greatly dissected, soils are relatively immature, show distinct zonation with a maximum thickness of 30 feet, a top surface of 30 ± 5 feet above the flood plain (pre-Bradyan Wisconsinan). The Qt 2 soils were deposited third (Qt 3 soils are mapped offsite) and mapped slightly elevated along the western side of Bois D Arc Creek basin approximately two miles south of the dam alignment.
 - Qt 1 terrace deposits consist of mostly sand, silt and some clay. These soils are moderately well bedded, mostly red to tan, surface scrolled, and are immature with B-horizon soils weakly developed or locally not recognizable, with a maximum thickness of 30 feet and a top surface of 17 ± 3 feet above the floodplain (post-Bradyan Wisconsinan). The Qt 1 soils that were deposited last, are mapped along the eastern flank of the creek basin, and approximately 3 miles south of the dam alignment (along the former confluence of Honey Grove Creek with Bois d'Arc Creek).
- The Bonham Formation (Kbo/Kbn) in Fannin County consists of waxy, greenish gray sandy marl containing glauconite locally. It becomes progressively sandier eastward. The formation weathers to yellowish gray. The formation is 375 to 530 feet thick. Progressing eastward, the Bonham Formation is a sub member facies change

equivalent to the lower Atco member of the Austin Chalk (Kau). The International Stratigraphic Guide (Salvador, 1994), Article 7-d indicates the Bonham Mudstone Member exposure at a train station locality in Bonham, Texas is a bluish gray, buff-weathering calcareous mudstone. The formation is mapped above and in contact with the Eagle Ford formation and forms the elevated hills flanking the Bois d'Arc floodplain valley to the west and east of the dam alignment.

- Eagle Ford Formation (Kef) in western Fannin County consists of medium to dark gray bituminous, selenitic shale with calcareous concretions, sandstone and sandy limestone. Total formation thickness is up to 350 feet thick. Near the Lamar-Red River County line the Eagle Ford grades to a less than 60-foot thick section of light gray, fine to coarse grained quartz sand with some tuff in the middle and conglomerate locally at the base. The formation is mapped as a thin, sinuous section cropping out along the east and west flanks of the floodplain of Bois d'Arc Creek and Honey Grove Creek.

A review of the boring data indicates that the Eagle Ford Formation at the site is overlain by a significant thickness of Ector Chalk (Ker). Refer to the Geologic Map provided as Figure 3-1: for the interpreted exposures of these various deposits and formations for the project site. This map and the original, unmodified map are provided for reference in Appendix B.

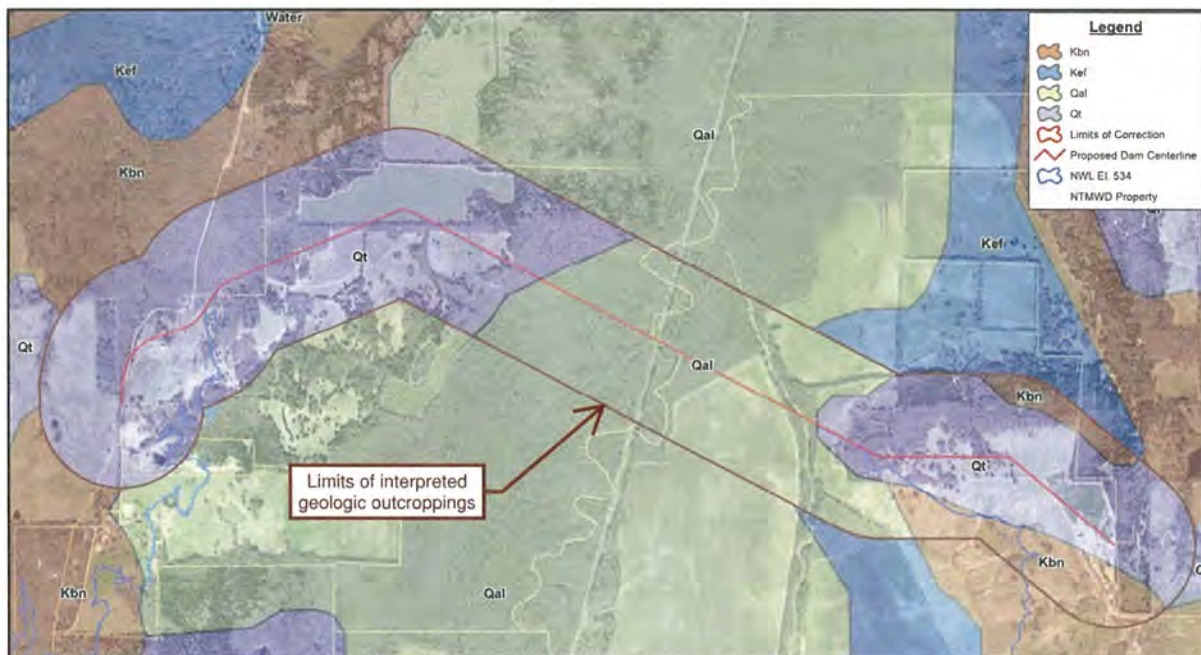

Figure 3-1: Geologic Map (Interpreted)

3.1.3 Structure

In northeast Texas, the Cretaceous age formations dip generally gulfward (to the south-southeast) below the land surface at approximately 30 to 80 feet per mile where uninterrupted by basement deformation. In portions of Grayson County and Fannin County, the basement structure underlying Cretaceous formations contain northwest to southeast trending warps forming syncline (dish) anticline (arch) structures. West of Fannin County through Grayson County, the major basement structural feature is the northwest to southeast-oriented Sherman syncline which is a part of the Marietta Basin that occurs at elevation -9,000 to -16,000 feet-msl. This syncline is generally overlapped and truncates to the southeast at the Ouachita thrust fault belt line that traverses north to south through eastern Grayson County.

The Ouachita fold belt represents an over thrust of a southern tectonic plate that advanced northward over the North American tectonic plate peaking about late Paleozoic time including early Permian time, about 300 million years ago (mya). Continued basement warping on the Preston anticline in Fannin County. The Preston anticline is a large arch of about 1,800 feet that plunges to the southeast through southwest Fannin County. East of this anticline, the basement structure down warps towards a syncline trending north 40 degrees west and recognized as the Kingston syncline. The Kingston syncline axis occurs approximately four miles west and 1,900 feet beneath the dam footprint and controlled the initial depositional structure for the Cretaceous sediments beneath the site. These basement structure folds formed the foundation for the marine Cretaceous deposits that cover the site vicinity.

3.1.4 Tectonic Faulting

No active faults (within last 11,000 years) are mapped in the vicinity of the site. Mapped faults for north central Texas are not shown to displace Quaternary surficial deposits. A band of southwest to northeast trending faults recognized as the Talco Fault zone is mapped as close as 37 miles southeast of the site and the Ouachita Mountain fold belt of Oklahoma is mapped approximately 68 miles northeast of the site. The Talco fault zone consists of a series of south-southeast dipping normal faults and grabens (downthrown block) mapped from east Texas

westward then arching southwest in north central Texas then more northerly in central Texas with an average width of approximately 5 miles. This zone represents an extension of the earth's surface that generally defines the northern and western limits of the Jurassic age LouAnn salt formation of the East Texas Basin. Activity of these faults is indicated to have occurred from the Jurassic (144 mya) until at least the Eocene (36.6 mya) in geologic time. A normal fault, trending north 25 degrees west is mapped over 9 miles and as close as 21 miles southeast of the site, displaces the Cretaceous Ozan formation with the sense of movement downthrown to the southwest. If extended, none of the fault traces would intersect the site.

Regional uplift elevated central Texas towards the Gulf during late Miocene (5.3 mya) (Sohl, 1991) resulting in a series of normal faults recognized as the Balcones Fault zone. The Balcones sub parallels and occurs 35 to 40 miles west of the Mexia Talco fault zone. Displacements of the Balcones fault zone include the Eagle Ford and Austin Chalk formations of the early Gulfian series. As mentioned, the Ouachita thrust belt is recognized approximately 30 miles west of the dam site deforming the basement structure at elevation -1,300 to -2,600 feet-msl. The current limits of the thrust belt are believed to have subsided at the end of the Triassic period geologic age (208 mya). A series of sub parallel northeast to southwest trending faults, anticline and syncline axes associated with the Ouachita Mountains of Oklahoma are mapped as close as 43 miles northeast of the site. Activity of these faults is associated with the formation of these mountains during pre-Mesozoic time (225 mya).

3.2 SEISMIC CONSIDERATIONS

3.2.1 Seismicity

TCEQ provides regulatory guidelines with respect to seismicity, but does not provide specific return periods or threshold values. In general practice, dams in this region of Texas are considered to have little risk of earthquake damage due to the lack of significant historic seismicity and the widespread occurrence of stiff clays and dense rock materials. Although the risk is considered low, the design considered potential seismic impacts. Peak horizontal ground accelerations are estimated at 0.05g to 0.08g along the base, but could potentially be amplified

to 0.19g to 0.27g at the crest. The likely earthquake magnitude associated with this response is in the range of 4.8 to about 6.1 on the Richter scale. These peak ground accelerations can be factored using a horizontal seismic coefficient (k_h) when used in pseudo-static slope stability analyses. A horizontal seismic coefficient of 0.45 is selected for this site, which results in a factored horizontal acceleration of 0.1215g. This is estimated to have a 2 percent chance of occurring within a 50 year time period or a mean return period of 2,475 years.

3.2.2 Liquefaction Potential

The liquefaction potential was evaluated for foundation beneath the proposed embankment. Soils considered potentially liquefiable included sandy soils with an equivalent clean sand blow count lower than 30 blows per foot and with a low fines content and low plasticity index. A factor of safety greater than 1.5 was determined for all identified locations except three, and this is considered sufficient to protect against liquefaction. Since there were factors of safety lower than 1.5 identified in three locations, the potentially liquefiable soils were also evaluated for potential ground settlement caused by a 5.5 magnitude earthquake. Potential ground settlement prior to construction of the embankment was 0.5 inches or less and after construction the estimated ground settlement was 0.6 inches or less. In addition, all these locations are located near the northwest end of the embankment, along the normal pool level. Therefore, no permanent impoundment against the embankment will occur in the area.

3.3 SITE AND SUBSURFACE CONDITIONS

3.3.1 Site Description

The regional landscape is a low rolling terrain dissected with a geomorphically mature flat floodplain valley. The site is tributary to the Red River watershed, including the confluence of northerly draining Honey Grove Creek with northerly draining Bois d'Arc Creek. Radial surface drainage is established along the elevated flanks to the east and west end of the dam footprint. Topographic elevations across the dam footprint range from approximately 464 feet-msl in the current Bois d'Arc Creek to elevated terraces of approximately 545 feet-msl on the west end and about 570 feet-msl on the east end (emergency spillway).

3.3.2 Subsurface Stratigraphy

The site geomorphology is expressed as a mature stream valley in a peneplain bound by lowland hills to the east and west in the vicinity of the dam footprint. Man-made realignment of Bois d'Arc Creek and Honey Grove Creek have resulted in incisement and terracing of the flat-lying alluvial sediments that cross the floodplain. The following list discusses the subsurface stratigraphy for the project site, starting from the terrace level downward.

- **Terrace Deposits (Qt)**: The borings encountered clay, sandy clay and sand river terrace deposits (Qt) ranging from 5 to 60 feet thick from Station 0+00 to Station 60+00, and from 1 to 20 feet thick from Station 105+00 to Station 111+00. Between Station 24+00 and Station 57+00, the ancient landscape had been scoured down to approximately elevation 476 feet-msl and resulted in sediments exhibiting lithological sequencing. Thin groundwater bearing zones were encountered at the base of these sediments.
- **Alluvial Deposits (Qal)**: A different and most recent fluvial phase show scouring had deepened the floodplain down to about elevation 442 feet-msl to 455 feet-msl between Station 60+00 and approximately Station 105+00. Subsequent alluvium (Qal) consists of predominantly 20 to 30 feet fat clay overlying less than 10 feet of loose to medium dense sandy clay and sand deposits. These sediments bottom out directly on massive limestone interpreted as the Ector Chalk (Ker) member of the Austin Chalk formation. Within the floodplain valley, the Ector Chalk had been scoured down to approximately elevation 456 feet-msl at Station 60+50 to elevation 444 feet-msl from Station 62+44 eastward to Station 111+58. West of Station 60+50 to Station 43+00, the top of the Ector Chalk was encountered from elevation 468 feet-msl to 475 feet-msl at Station 56+44 with an undulated elevation of 453 feet-msl between Station 14+47 and Station 33+93.
- **Bonham Marl (Kbo/Kbn)**: These Qt deposits rest on weathered gray with yellow-brown shaly clay marl containing silt partings transitioning to unweathered dark gray marl with silt partings recognized as the Bonham Marl (Kbo/Kbn) between Station 7+60 and about Station 94+00. The Bonham Marl materials was encountered intermittently between Station 52+50 and Station 60+00, and from Station 81+00 to the eastern emergency spillway borings. Bonham Marl formation materials were interpreted as deep as Elevation 457 feet-msl to 454 feet-msl between Station 14+47 and Station 33+93 respectively, and Elevation 455 feet-msl and 475 feet-msl between Station 96+00 and Station 110+58, respectively. The Bonham Marl materials had been removed by fluvial scour between Station 56+44 and Station 77+00 and intermittently

from Station 81+00 to Station 96+00. The unweathered marl was generally over consolidated and massive becoming calcareous and fissile with increasing depth. Except for the transition from weathered to unweathered, very few secondary structures or discontinuities were observed in the Bonham Marl.

- Ector Chalk (Ker): The Ector Chalk member was encountered across the entire footprint of the dam. The Ector Chalk is a light gray and gray moderately cemented limestone that is predominantly massive but with occasional fissility on low angle bedding planes and occasional mineral-healed joints or slickensides. Observed joints were tight. Thickness of the Ector Chalk ranges from 40 to 60 feet. A dark gray sandy clay marl of varying thickness underlies the limestone at approximately elevation 410 feet-msl. This marl was over consolidated, occasionally shaly and contained fossil fish skeletal debris and a thin seam of coarse rounded phosphate sand. The entire Ector Chalk limestone section between Station 8+78 to approximately Station 39+00, and approximately Station 97+00 to Station 110+58 is directly overlain with dark gray marl/shale of the Bonham Marl.
- Eagle Ford Shale (Kef): Below the sandy marl layer from about elevation 400 feet-msl to 395 feet-msl, the deep borings encountered weakly to moderately cemented calcareous sandstone partings, seams and layers transitioning quickly to a dark gray sandy shale and shale. This horizon of material is interpreted as the Eagle Ford Formation (Kef) group. The Eagle Ford Formation group includes the Maribel Shale member overlying the Bells Sandstone member. The sandy portions demonstrated cross bedding. The sandstone, sandy shale and very dense sand encountered during drilling. The shale was over consolidated and weakly to non-calcareous. Elevations for the interpreted Eagle Ford Formation materials from the borings do not correlate with elevations mapped on Geologic Atlas for Texas-Texarkana Sheet.

The stratigraphy can be subdivided and described into three groups: 1) the left terrace, 2) the valley section, and 3) the right abutment and service spillway; as shown in Table 3-1, Table 3-2, and Table 3-3. The generalized subsurface profiles for these generalized sections are shown in Figures 3-2, 3-3, and 3-4, respectively.

Table 3-1: Generalized Stratigraphy – Left Terrace

Stratum	Description	Thickness	Elevation Range
1A	Terrace Overburden: LEAN and FAT CLAY (CL, CH); color is generally brown, gray and yellow brown; includes layers of clayey sand/sand, particularly on far left	40 to 45 feet	542 to 485 ft-msl
1B	Terrace Overburden: SANDY LEAN CLAY (CL) and CLAYEY SAND (SC); color is generally light gray, yellow to red brown; consistency is generally stiff to very stiff	10 to 15 feet	488 to 470 ft-msl
2	Bonham Shale Bedrock: SHALE and MARL, slightly weathered, gray to dark gray; fissile and occasionally jointed; with some sand partings	5 to 45 feet	474 to 454 ft-msl (increases to 511 on far left)
3	Ector Chalk Bedrock: LIMESTONE, generally unweathered, light gray to gray; occasionally marly and fissile; occasionally jointed; with some sand partings	Up to 60 feet	477 to 454 ft-msl

Table 3-2: Generalized Stratigraphy – Valley Section

Stratum	Description	Thickness	Elevation Range
1A	Alluvial Overburden: FAT CLAY (CH); color is generally brown and gray; includes occasional layers of lean clay (CL) and clayey sand (SC)	16 to 35 feet	481 to 445 ft-msl
1B	Alluvial Overburden: SANDY LEAN CLAY (CL) and CLAYEY SAND (SC); color is generally light gray, yellow to red brown; consistency is generally stiff to very stiff	2 to 10 feet	462 to 444 ft-msl
2	Bonham Shale Bedrock: SHALE and MARL, slightly weathered, gray to dark gray; fissile and occasionally jointed; with some sand partings	4 to 6 feet	465 to 440 ft-msl
3	Ector Chalk Bedrock: LIMESTONE, generally unweathered, light gray to gray; occasionally marly and fissile; occasionally jointed; with some sand partings	33 to 53 feet	458 to 400 ft-msl
4	Eagle Ford Shale Bedrock: SHALE and SANDSTONE, unweathered, dark gray; occasionally marly and fissile; occasionally jointed; with some sand partings	Up to 45 feet	403 to 393 ft-msl

Table 3-3: Generalized Stratigraphy – Right Terrace and Service Spillway Centerline

Stratum	Description	Thickness	Elevation Range
1A	Terrace Overburden: SAND to CLAYEY SAND (SP, SC); color is generally red brown; includes layers of lean clay; generally capped with thin mantle of fat clay	8 to 14 feet	550 to 534 ft-msl
1B	Terrace Overburden: FAT CLAY (CL, CH); color is generally gray and yellow brown; residual material weathered from the Bonham formation; shaly appearance and jointed	10 to 16 feet	539 to 516 ft-msl
2	Bonham Shale Bedrock: SHALE, slightly weathered, gray to dark gray; occasionally marly with mudstone appearance; with some gypsum	33 to 42 feet	523 to 474 ft-msl
3	Ector Chalk Bedrock: LIMESTONE and MARL, unweathered, light gray to gray; occasionally fissile and jointed	Up to 50 feet	481 to 474 ft-msl

KEY TO SYMBOLS

- CH: USGS High Plasticity Clay
- CL: USGS Low Plasticity Clay
- CI: USGS Well-graded Gravel
- CM: USGS Medium Plasticity Clay
- CU: USGS Clay with Sand
- LM: USGS Limestone
- MA: MARL
- MB: MUDSTONE
- MS: SANDSTONE
- SC: USGS Clayey Sand
- SH: SHALE
- SM: USGS Silty Sand
- SP: USGS Poorly-graded Sand
- SS: USGS Silty Sand
- SW: USGS Well-graded Sand

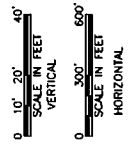
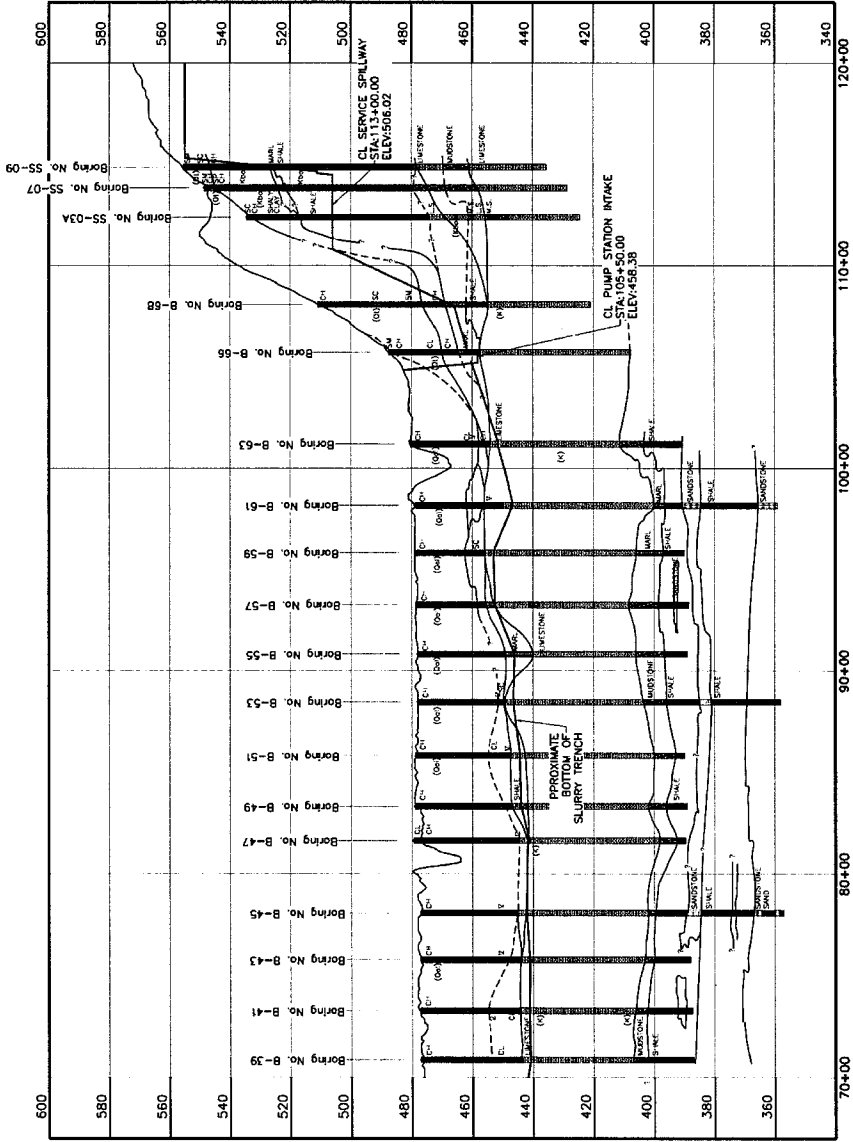

FIGURE 3.3

NORTH TEXAS MUNICIPAL WATER DISTRICT
 LOWER BOIS D'ARC CREEK RESERVOIR
 EMBANKMENT CENTERLINE (2/2)
 GENERALIZED SUBSURFACE AND GEOLOGIC PROFILE

DATE	REV	BY
10/27/2015		
PROJECT	NO.	
DESCRIPTION		
CLIENT		
DESIGNER		
CHECKED		
DATE		

FRESE & NICHOLS
 1005 Westwood Park, Suite 200
 Fort Worth, Texas 76104-5502
 Phone: (817) 732-7200
 Fax: (817) 732-7441
 Web: www.fresenichols.com

Prepared by: [Name]
 Checked by: [Name]
 Date: [Date]

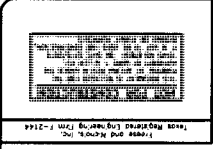

FRESE
NICHOLS
 1405 West Loop West, Suite 519
 Houston, Texas 77027
 Phone: (713) 231-2200
 Fax: (713) 231-2800
 www.freesenichols.com

GENERALIZED SUBSURFACE AND GEOLOGIC PROFILE
SERVICE SPILLWAY
CIVIL
LOWER BOIS D'ARC CREEK RESERVOIR
NORTH TEXAS MUNICIPAL WATER DISTRICT

DATE	11/15/2015
BY	JRN
CHECKED BY	JRN
SCALE	AS SHOWN
PROJECT NO.	1501-010
DRAWING NO.	010
DATE	11/15/2015
BY	JRN
CHECKED BY	JRN
SCALE	AS SHOWN
PROJECT NO.	1501-010
DRAWING NO.	010

FIGURE 3.4

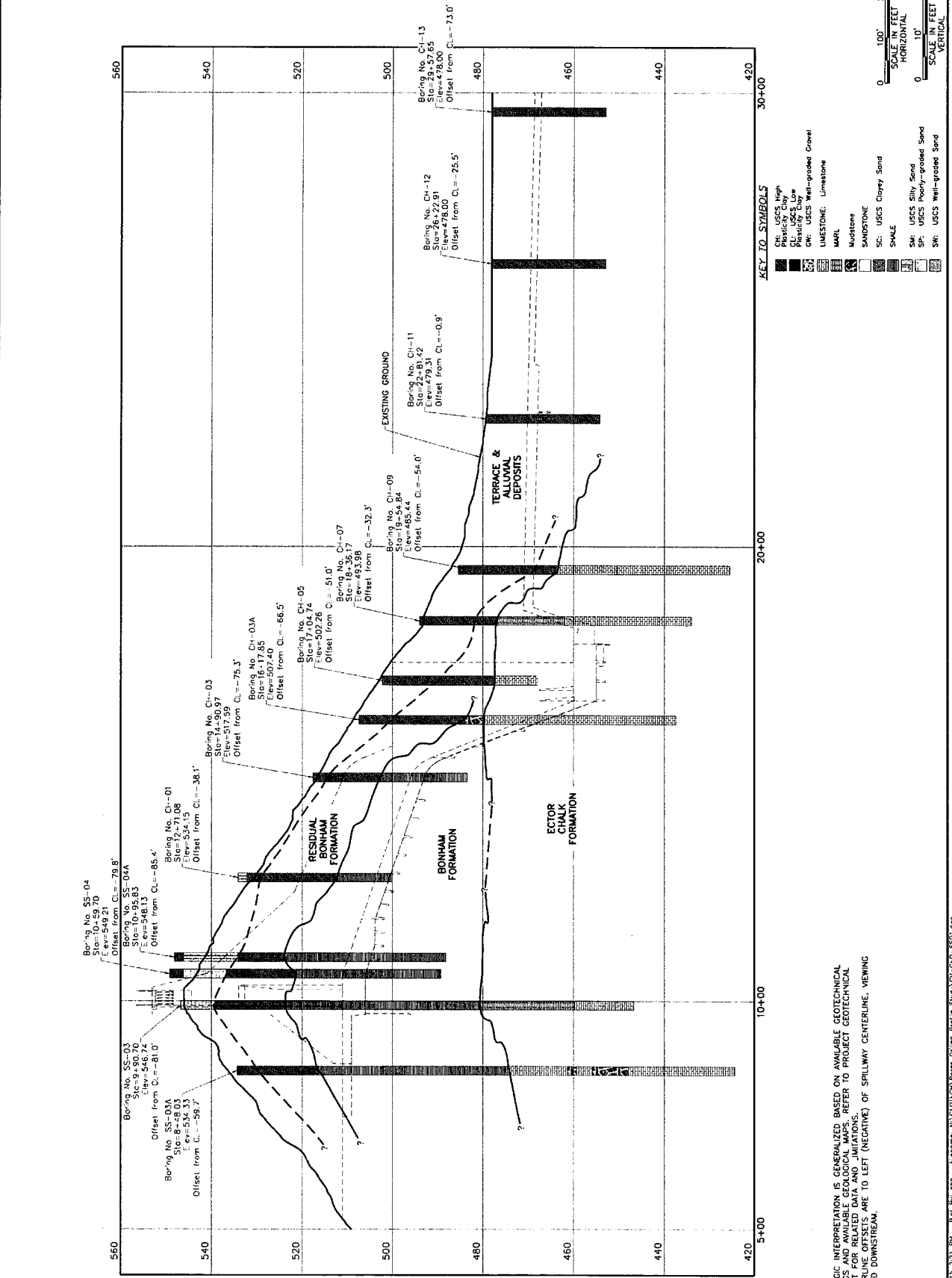

NOTES:

1. GEOLOGIC INTERPRETATION IS GENERALIZED BASED ON AVAILABLE GEOTECHNICAL BORINGS AND AVAILABLE GEOLOGICAL MAPS. REFER TO PROJECT GEOTECHNICAL REPORT FOR RELATED DATA AND LIMITATIONS.
2. ELEVATIONS ARE TO LEFT (NEGATIVE) OF SPILLWAY CENTERLINE, VIEWING TOWARD DOWNSTREAM.

3.4 GROUNDWATER

The proposed reservoir is underlain by several aquifers, including the Woodbine Aquifer and Northern Trinity Aquifer, which are considered as significant regional aquifers. These two aquifers are recognized as aquifers by the State of Texas. Groundwater in Fannin County is also produced from the Blossom Aquifer (member of the Austin Chalk), the Red River alluvial aquifer and an unnamed, shallow aquifer beneath the proposed reservoir. These aquifers are discussed below:

- The Woodbine Aquifer is a significant source of groundwater supply in Fannin County. The Woodbine Formation consists of strata of water-bearing sandstone interbedded with shale and clay. The aquifer outcrops along the Red River and dips south and eastward to depths of over 2,500 feet below land surface with a thickness of about 700 feet (LBG-Guyton, 2003).
- The Trinity Aquifer lies beneath the Woodbine Aquifer. The Trinity Group strata in the county generally consists of sands, limestone, shale and clay of the Paluxy Formation. The Trinity does not outcrop in the county and very little groundwater is produced from this aquifer in the county. The few groundwater wells installed into the Trinity are more than 3,000 feet deep and are located in the southeastern portion of the county.
- The Blossom Aquifer is a designated minor aquifer by the Texas Water Development Board but little groundwater is produced by this aquifer. Production has been limited to eastern Fannin County and utilized for livestock or domestic use.
- Shallow alluvial aquifers, including the Red River Alluvium, are present within the county. None are officially designated as minor aquifers by the state of Texas but a significant amount of groundwater production occurs within these alluvial aquifers, especially in the northern half of the county. The groundwater is mainly used for irrigation purposes.

As part of the geotechnical investigation for the project, observations were made during drilling for the occurrence of seepage and/or the collection of groundwater. The borings were drilled using a combination of techniques, and most of the borings were advanced using drilling fluid during rotary wash and rock coring. Observations for seepage and groundwater were made prior

to the introduction of the drilling fluid, when applicable. When drilling fluid was not used, observations were also made at the end of drilling.

In general, the groundwater was encountered in the leaner/sandier material just above the base of the bedrock materials, particularly along the left terrace. This is generally demonstrated by reviewing the readings within the piezometer installations, which are presented in Section 2.0. Note that many of the valley piezometers (B-34 to B-73) show an increase in the piezometric level during June of 2015 when very heavy rainfalls were experienced.

4.0 CARE OF WATER AND CONSTRUCTION SEQUENCING

In order to construct the Lower Bois d'Arc Creek Reservoir Dam across Bois d'Arc Creek and Honey Grove Creek, it will be necessary to temporarily divert and control the flows from both of these creeks during construction. The diversion or care of water during construction is broken up into three separate phases. Phase 1 consists of diverting flow from Honey Grove Creek to Bois d'Arc Creek. This phase will provide the means of passing the combined inflows, diverting stream flows, and will be in place until such a time as the Phase 1 closure section can be completed on Bois d'Arc Creek. During this phase the intake tower and conduits, portions of the spillway, and the embankment on either side of Bois d'Arc Creek up to at least elevation 505 will be constructed. Phase 2 consists of diverting flow through the pump station intake structure and suction piping. This phase will start upon closure of the Phase I embankment at Bois d'Arc Creek and will remain in place until the reservoir impoundment process begins. After completion of the closure section, the slurry trench will be constructed and the remainder of the embankment up to at least elevation 538 will be completed, including erosion protection. In addition, the entire spillway, with the exception of the labyrinth weir walls, will be completed. Phase 3, the impoundment Phase, will begin once the structure meets TCEQ approval for safe operation, estimated as passing 75% of the PMF. This is described in Section 4.1.3. Then, inundation up to Elevation 511 will commence while the remainder of the project is completed. Sheet A-7 of the contract Drawings describes the sequence in more detail and Section B shows the requirements for the embankment related to the diversion sequence.

4.1 DIVERSION PHASES

4.1.1 Phase 1 Conditions

In order to determine the appropriate size of the closure channel at Bois d'Arc Creek, several moderate frequency design storms were considered. These storms were the 5-year, 10-year, and 25-year events in the Bois d'Arc Creek and Honey Grove Creek watersheds. It was determined through the use of a HEC-RAS model of the existing conditions for the Lower Bois d'Arc Creek that the flows for even the 5-year storm were out of the creek banks and into the flood plain

(approximate elevation 480.0 feet-msl). Table 4-1: shows the peak inflow and peak elevation of each of these storms.

**Table 4-1: Design Inflows and Peak Elevations for the Lower Bois d’Arc Creek Reservoir
Phase I Conditions**

Storm	Peak Inflow (cfs)	Peak Elevation (ft-msl)
5 yr	21,526	482.81
10 yr	29,089	484.31
25 yr	38,068	486.52

Based on the results shown in Table 4-1; it was evident that a relatively large closure would be needed. The Phase 1 closure section was set to 100 feet wide at the base with 3H:1V side slopes above the creek bank. In order to use only one closure section for the embankment, it is necessary to connect Honey Grove Creek and Bois d’Arc Creek. This was accomplished with a 60-foot wide connection channel upstream and downstream of the dam. The connection channel upstream of the dam will be converted into the inlet channel for the pump station intake for Phase 2 of the care of water plan and for the completed project. The channel downstream connects to the spillway exit channel and will be filled in during the impoundment phase once the 30” low flow release pipe is operable. Cofferdams will be necessary across the existing creeks in order to prevent diverted water from entering these low areas of the project. The location and sizing of the coffer dams will be the responsibility of the Contractor.

4.1.2 Phase 2 – Closed Conduit Diversion

The size of the pump station intake structure and pipes is determined by the peak pumping capacity for the pump station. Since these structures are the only low level intake structures in the lake, it is necessary to use these structures to pass stream flows during the completion of the closure section. The discharge rating curve for the intake structure is driven by the intake pipeline, which consists of two 78-inch diameter mortar lined steel pipes. As the closure section and the Phase 2 diversions progress, any inflows to the reservoir will be temporarily impounded behind the embankment and will gradually be drained with the closed conduit diversion. In order to avoid the risk of overtopping the closure section, it will be necessary to construct the closure section rapidly. shows the peak water surface elevations associated with the 5-year, 10-year, 25-

year, and 100-year storms using only the storage capacity of the reservoir and the closed conduit diversion to pass the flows. These assume they have full storage (480.0) at the beginning of the event.

Table 4-2: Design Inflows and Peak Elevations for the Lower Bois d'Arc Creek Reservoir (Closed Conduit Diversion)

Storm	Peak Inflow (cfs)	Peak Outflow (cfs)	Peak Elevation (ft-msl)
5 yr	31,923	1,250	500.8
10 yr	42,240	1,324	504.1
25 yr	51,654	1,385	506.9
100 yr	67,449	1,479	511.1

The configuration of the Phase 1 fill is drawn in Section B of the Contract Drawings. The upstream half is set at 505 to stay above the 25 year flood. The downstream half will be at elevation 515 to be higher than the crest of the service spillway (elevation 511) to avoid overtopping of the embankment from larger events. For this reason, the labyrinth weir walls may not be constructed until later in the project.

4.1.3 Phase 3 – Impoundment Phase

Due to the urgent water supply needs of the Owner, the design incorporates the ability to initiate permanent impoundment prior to completion of the project. The necessary configuration prior to impoundment will be subject to TCEQ approval, but for planning and design purposes, it was assumed that the dam would need to be able to pass at least 75% of the PMF at all times once impoundment began.

The only opportunity for releasing flood waters at lake levels below conservation pool level other than the intake structure will be the crest of the service spillway if the labyrinth weir walls are not constructed initially. This would be at elevation 511.0. Therefore, a logical partial impoundment level would be up to elevation 511 prior to completion of the project. Analyses were made to determine the 75% PMF level if water was stored to elevation 511. Table 4-3 shows both the 75% and 100% PMF with and without the labyrinth weir walls in place. For the 100% PMF run, it was assumed that the emergency spillway was completed.

Table 4-3: Peak Design Flood Elevation, with Early Impoundment at Elevation 511.0

Flood Event	Peak Elev. without Weir Walls	Peak Elev. with Weir Walls
75% PMF	538.2	540.5
100% PMF	539.6	543.8

Based on these findings, it was estimated that the project could be safely operated with a starting pool level of up to 511.0, if the embankment was up to at least 538 and the labyrinth weir wall was not installed, or up to 540 if the wall was installed. For comparison, the project would pass the full PMF, which is the TCEQ requirement for large, high hazard dams, though with no freeboard, if the embankment were up to elevation 540.5 without the weir wall installed and elevation 544 with it in place. Both assumed a starting level of 511 and the emergency spillway in place.

Based on these results, the plans for the impoundment phase will require that the embankment be up to at least elevation 538 with the service spillway completed except for the weir wall, before the gates can be closed to start impoundment. The TCEQ will have to provide approval for this phase to begin. The service spillway will then be treated as an uncontrolled spillway with a crest at 511 until the embankment is up to at least at 540 and the emergency spillway is complete. The weir walls can then be completed. If the contractor prefers to not wait to install the weir walls, then the embankment would need to be up to at least 540 prior to impoundment. The contractor will be responsible for completing other portions of the project that may be impacted by impoundment up to elevation 511.

In addition, a separate project will be responsible for resolving other unrelated issues within the reservoir area, such as the construction of FM897, the replacement of multiple utilities, and clearing of large portions of the reservoirs. These will also need to be completed prior to the impoundment phase, but will not be the responsibility of the dam contractor.

5.0 EMBANKMENT

5.1 GENERAL

Previous conceptual and Preliminary Design efforts established that the Lower Bois d'Arc Creek Reservoir Dam will be a zoned earthen embankment with a low-permeability core and a chimney and blanket filter/seepage collection system. Based on the design PMF elevation of 550.0 feet-msl, the proposed design crest is established at Elev. 553.0 feet-msl to provide the minimum required free board. The total length of the proposed dam is about 11,200 linear feet, and can generally be divided into a terrace section and a valley section, as follows:

Valley Section: The valley section is on the right half of the alignment and is approximately 6,100 linear feet. This portion of the dam is founded at a lower elevation than the terrace section, which results in a maximum embankment height of about 75 feet above the surrounding grade (not including the creek crossings). The right portion of the valley embankment ties into the right abutment in the area of the Service Spillway, while the left portion of the valley embankment ties into the left abutment where the valley section slopes into the terrace section in the area of Station 51+00. The embankment for this valley section will include impoundment for all reservoir levels.

Terrace Section: The terrace section is on the left half of the alignment and is approximately 5,100 linear feet. This portion of the dam is founded at a higher elevation than the valley section, which results in a maximum embankment height of 20 to 25 feet above the surrounding grade. The embankment for this terrace section will generally only impound events above the normal pool, with a portion of the section impounding up to a few feet of water at the normal pool level.

The data from this study was used to develop the analysis and recommendations for the design of the embankment dam, as detailed in the following sections.

5.2 HIGHLY PLASTIC CLAY ISSUES

It is generally desirable to zone dam embankments to include the highly plastic, fat clays (CH) in the core and then use more desirable lean clays, granular soil and/or rock fill materials for the shells. As previously discussed, the site and surrounding area has limited desirable material available and high plasticity clay material will be used extensively because of its availability. The use of clay does create several issues that were considered during design. The significant issues are discussed in the following list.

- Lateral Bulging of Slopes: Research indicates that tall, fat clay slopes can develop bulging of the slopes in response to settlement. An empirical method published by Walker and Duncan (1984) showed results of 2 to 3 feet of potential lateral slope bulging for a similar project. This movement does not typically create slope stability issues, but is an item that must be monitored. However, slope bulging could negatively affect the intake tower (depending on location) and the bridge used to access the tower. This issue is under consideration and will be addressed during the Final Design.
- Downstream Mid-slope Berm: The use of clays on the surface of the taller portions of the embankment increases the risk of surface erosion. A mid-slope berm is recommended on the downstream slope to reduce this mechanism, and also to allow for easier long-term monitoring and access to instrumentation.
- Flatter Slopes and Toe Berms: Fat clays are known to develop shallow surface slides. This is particularly true in Texas due to large seasonal variations. This issue factored into the decision to flatten the slopes to 3.5H:1V. The flatter slopes also improve maintenance access. Toe berms are also recommended for both slopes to reduce the effective height of the embankment and thereby reduce the potential and location of shallow surface slides. The upstream toe berm also reduces the required soil cement quantity.
- Continuous Blanket Filter: Conceptual level design considered the use of intermediate finger drains in lieu of a continuous blanket filter. The analysis indicates that finger drains are not desirable in the taller portions of the embankment because the clays between the drains can develop elevated pore pressures.
- Construction Holds Related to Pore Water Pressure: Clay fills will develop pore water pressure due to their slow draining properties. For fat clays and deep fills, this can result in slope instability and/or excessive slope deformation. It is often necessary to

monitor pore pressure development and limit fill placement rates to control this issue. Occasionally, construction holds may be necessary to control this issue.

- Increased Instrumentation: As noted above, fat clay fills can develop excess pore water pressures. Construction instrumentation is generally required to monitor the condition of large embankments, but those with fat clays typically require more instrumentation when compared to more desirable embankment materials.
- Expansive Soil Movement: The fat clays will experience shrink and swell with seasonal moisture cycles. These movements will be accounted for in the design of structures and the crest elevation, but the embankment will develop desiccation cracking during the hot and dry periods. This type of desiccation cracking should not threaten global stability, but does increase the potential for the surface soil to develop fully-softened shear strengths and related surficial slides.
- Increased Maintenance: As noted above, fat clay slopes have an increased risk of developing surficial slides. Although the flatter slopes will reduce the occurrence of these slides, it will not eliminate them. The NTMWD will have to address these types of slides if and when they occur. Generally, these types of slides can be dealt with operationally with conventional earth-moving equipment.
- Slope Maintenance Access: The clay slopes will be more likely to rut following rainfalls, and it is desirable to limit maintenance activities on the slopes following rainfalls. This is usually not an issue, but can be problematic during periods of frequent rainfalls because they can accelerate grass growth while also limiting mowing equipment access.

The use of the available clays will result in a significant cost savings for the NTMWD, and the appropriate response to the above issues during design and construction will allow for the successful use of these clays as embankment fill. These items were considered for the section geometry selection discussed below.

5.3 SECTION GEOMETRY

The schematic section for the permit application established the upstream and downstream slopes at 3H:1V, based on typically acceptable geometries. The schematic section included a centerline slurry cutoff trench, and a continuous chimney drain with isolated finger drains below the downstream shell. This chapter details additional analysis performed to establish the

embankment geometry based upon site specific data and the design efforts. The embankment selected for the Preliminary Design (30% Design) varied from the schematic section in that the downstream slope ratio was flattened to 3.5H:1V based on the expected improvement to both deep-seated and shallow slope stability. The schematic section was also modified to potentially include a continuous blanket filter as a potential alternative to isolated finger drains.

Since the Preliminary Design, modifications to the typical embankment section have occurred. A generalized cross section with these modifications is shown in Figures 5-1 , 5-2, and 5-3. The sections also show the Phase 1 fill levels as described in Chapter 4. Refer to the following list and Section B of the Contract Drawings for a description of the modifications. Side slopes are still 3.5:1 (H:V) for all cases.

- The design embankment crest elevation will include up to an 18-inch overbuild to account for post-construction settlement (overbuild will vary proportionally with embankment height).
- The upstream slope includes a 20-foot berm at Elevation 505 ft-msl (from approximate Station 54+50 to 108+00).
- The downstream slope includes a 15-foot berm at Elevation 520 ft-msl (from approximate Station 56+00 to 106+00).
- The downstream slope includes a 25-foot toe berm at Elevation 490 ft-msl through the valley section (approximate Station 56+00 to 106+00). The toe berm transitions with the topography along both the left and right terraces.
- The downstream shell of the embankment will be constructed from primarily lean and fat clay materials excavated from onsite borrow areas.
- The slurry cutoff trench was offset approximately 90 feet upstream of the centerline, and will be constructed from the top of Phase 1.
- The embankment includes an extensive internal drainage system, described in Section 5.7.
- Erosion protection will consist of soil on the upstream slope, described in Section 5.8, and grass on the downstream slope.

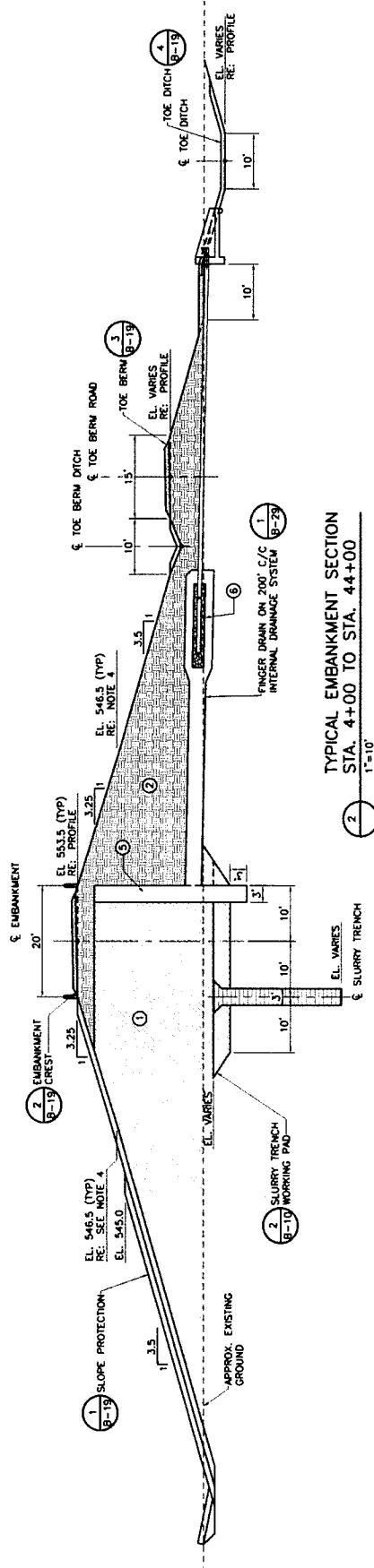

Figure 5-1: Typical Section – Left End through Station 44+00

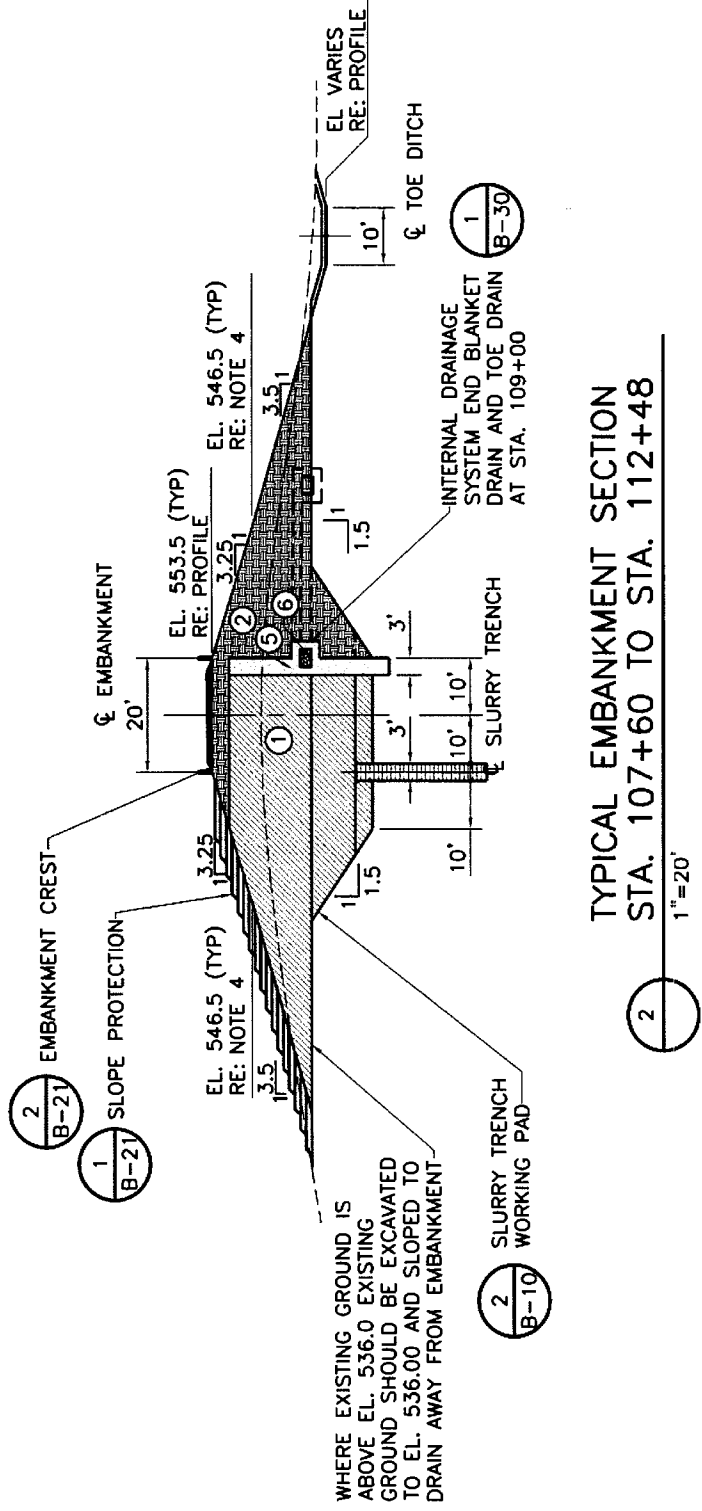

Figure 5-3: Typical Section – Station 107+60 through Right End

5.4 FOUNDATION AND CUTOFF

As discussed in Chapter 3, the subgrade below the proposed embankment consists of consolidated fat clays with some occasional clayey sand and sand/gravel deposits. These deposits are alluvial in nature, and the stratigraphy varies somewhat as a result of this depositional environment. The thickness of the overburden varies, but is generally between 20 and 30 feet thick, and is up to 60 feet thick on the left half of the valley section. The transition in the thickness of the overburden is gradual, with transitions flatter than 10 percent. The clays will significantly limit foundation seepage, but the presence of sand and sandy units could provide potential underseepage windows. The clays generally have low shear strength and will consolidate slowly in response to loads.

The “bedrock” that underlies these overburden deposits is primarily limestone and marl that include shale, sandstone and mudstone units. Although this bedrock is soft relative to common rock classifications, it provides a suitable and consistent boundary layer for the dam structure. In particular, the bedrock is considered incompressible and impermeable, and can be used to limit potential failure mode risk factors, such as underseepage.

To verify the permeability characteristics of the bedrock, packer tests were performed in the bedrock during the geotechnical study. These tests indicated that the permeability of the bedrock is low, often indicating a “no-take” result for the duration of the field test. Permeability tests performed on the rock materials in the laboratory ranged from 2.0E-09 cm/sec to 7.8E-10 cm/s with an average permeability of 3.3E-09 cm/sec. This data indicates that the bedrock is a low-permeability layer that will act as an effective component of a cutoff system. The data also suggests only minor differences in the permeability of the various bedrock units across the length of the alignment, which is expected based on their classification and the field observations.

The design considered three options for providing a foundation cutoff. The first was a conventional clay-filled, open-cut excavation cutoff. The open cutoff was eliminated from consideration due to the relatively deep bedrock and the estimated high cost of performing such substantial quantities of earthwork, and addressing dewatering concerns and trench safety

concerns. A cost comparison indicated that a slurry cutoff wall would be a more economical method. The second and third options were two types of slurry cutoffs. A cement bentonite (CB) slurry cutoff wall utilizes a bentonite slurry containing cement to stabilize the trench during excavation, and after completion of the excavation, the cement causes the slurry to harden to a strength comparable to that of a stiff clay. A soil bentonite (SB) slurry cutoff wall utilizes a bentonite slurry to stabilize the trench during excavation, and after completion of the excavation, the excavated soil that is suitable is mixed with the bentonite slurry to create a homogeneous backfill material which is then placed back into the trench to create a low permeability water barrier through the foundation.

Soil bentonite cutoff walls have shown suitable performance for many years as low permeability cutoff structures associated with water retaining facilities. In particular, many dams use SB slurry cutoff walls as the primary means of foundation seepage cutoff. The benefits associated with SB slurry cutoff walls include rapid construction time (especially for cutoff walls less than 70 feet deep), low permeability, and low construction cost compared to other water barrier technologies.

Cement bentonite slurry cutoff walls have demonstrated suitable performance in several specific site conditions. Since a CB slurry cutoff wall does not require that the excavated material be used as backfill, this type of cutoff serves well where the existing foundation material is unsuitable for use as backfill (i.e. high organic contents). A CB slurry cutoff wall is also beneficial where working room is limited and/or the cutoff is located in close proximity to existing structures. This is because CB slurry cutoff walls are constructed in 50-foot panels, typically using a clam shell excavator, and do not require the long flat runs that are required for SB slurry cutoff wall construction. Finally, CB walls have proven effective when providing a cutoff across a highly permeable foundation material or one with high permeability zones. These types of foundations can lead to increased seepage gradients across the cutoff itself, which in turn leads to the possibility of internal erosion of the cutoff. Since CB slurry cutoff walls are composed of cementitious material, they are more erosion resistant than SB slurry cutoff walls. CB slurry cutoff walls are, however, around 1.5 to 2 times more expensive than SB slurry cutoff walls. Since

none of the site specific concerns that drive a design towards CB slurry cutoff walls are present at the Lower Bois d'Arc Creek Reservoir Dam site, and given the performance history of SB slurry cutoff walls at other dams, a SB slurry cutoff wall is the preferred option for this site.

The positive cutoff for the dam foundation will be a soil bentonite slurry trench constructed during the diversion phase of construction. The cutoff wall will consist of a 3-foot wide homogeneous site-mixed soil bentonite backfill. The slurry trench will be constructed from the natural ground level from Station 4+00 to Station 57+30; from the top of the Phase 1 Embankment from Station 57+30 to Station 107+30; and from a partial open cutoff trench from Station 107+30 to Station 110+75. In section the cutoff trench will be located 10 feet upstream from the dam centerline except from Station 57+30 to Station 107+30 where it is located 90' upstream from the dam centerline. The cutoff wall will include a working platform from which all excavation and backfill operations are conducted. The working platform will be at minimum 3 feet thick and constructed of select embankment core material. This working platform will provide a sufficient key between the cutoff wall and the embankment core when the SB material settles over time. The bottom of the cutoff wall will be keyed a minimum of 3 feet into the bedrock. Refer to Section B of the Contract Drawings for the typical cutoff sections relative to the complete embankment.

For the analysis and design, the slurry trench was assumed to have a permeability at or less than 10^{-7} cm/sec. The mix-design will be provided by the construction manager at risk (CMAR) to meet this permeability requirement.

It was determined that no cutoff wall is necessary from Dam Centerline Station 0+00 to Station 4+00 because the existing ground elevation in this area is significantly higher than the normal water level. Additionally, the seepage path is very long for seepage that could occur around the end of the cutoff wall. The same analysis was performed for the area between the service spillway and the emergency spillway (Station 115+00 to Station 125+00) to study the need for extending the cutoff through this area. Refer to Volume 3 of the Geotechnical Investigation Report for specific analysis results in these areas.

The topography from Station 113+48 to 115+00 is not conducive to the construction of a SB cutoff wall. For this reason, the foundation cutoff in this area will consist of an open trench backfilled with embankment core material (fat clay). The trench will be 20 feet wide at the base with 1.5H:1V side slopes and will be keyed 3 feet into the bedrock.

5.5 EMBANKMENT STABILITY ANALYSIS

The short-term and long-term stability of the embankment is critical to the longevity of the project. An analysis of various time intervals and loading conditions is desired to study the stability of the embankment system, and potential failure modes with regard to seepage forces, global/slope instability, and settlement.

Since the Preliminary Design Report, two additional sections were studied for stability for a total of eight embankment cross sections. The sections were selected such that each section represents various heights of the embankment and relatively different subsurface stratigraphy. Note that the dam centerline stationing was adjusted, and that the section stations referenced in the Preliminary Design Report differ by about 4+00 feet. The selected sections with a brief description are as listed below. Refer to Plate 12 in Appendix B for plan of cross sections for all eight cases.

- Station 19+00: Embankment 21 feet tall, up to 29-foot of CL clay, SW/SP sand, and CH clay overburden above bedrock.
- Station 28+00: Embankment 21.5 feet tall, 59-foot overburden section of CL and CH clay above bedrock with some SC clayey sand overburden on upstream side.
- Station 58+00: Embankment 51.5 feet tall, 22 to 34-foot overburden section of CH clay with a discontinuous layer of SC clayey sand and SP sand above bedrock.
- Station 58+01: Embankment 51.5 feet tall, 23 to 25-foot overburden section of CH clay with a continuous layer of SC clayey sand above bedrock.
- Station 78+00: Embankment 77 feet tall, 31 to 32-foot overburden section of CH clay above layered bedrock.
- Station 98+00: Embankment 74 feet tall, 59 feet of CH clay overburden above layered bedrock.

- Station 106+00: Embankment 69 feet tall, 27-foot overburden section with CH clay with SC clayey sand on upstream and downstream sides, above layered bedrock.
- Station 106+00: Embankment 40 feet tall, 27 feet of CH clay on upstream side, and 37 feet of SC clayey sand on downstream side, above layered bedrock.

The analysis was performed on these eight sections. Although the results for all eight sections are discussed below, the figures associated with the analyses are only presented for the critical section at Station 78+00 (see Plates 13 through 16 in Appendix B). Refer to Volume 3 of the Geotechnical Investigation Report for the detailed analysis and results for all eight sections.

5.5.1 Seepage Analysis

It is desirable to perform a seepage analysis for the embankment to confirm the suitability of the proposed internal drainage system and to calculate pressure regimes within the embankment and foundation. Once a steady-state seepage regime is analyzed and established, it is desirable to consider the potential for the following potential failure modes:

- Heave of Cohesionless Deposits (movement or boiling of individual particles)
- Uplift and Blowout of Clay Blankets (lifting of blankets)
- Backward Erosion Piping of Erodible Materials (piping)

Because the stratigraphy of the foundation is predominately a thick layer of cohesive material, the potential for the first two failure mechanisms is considered low. The third mechanism (piping) also has a low probability of occurrence but is considered possible due to the ability of the overburden material to resist collapse. However, all three methods are analyzed to benchmark the expected performance of the embankment system.

The seepage analysis was performed for each of the eight cross sections at four pool levels (Normal Water Surface (NWS), 100-year flood, 500-year flood and PMF). The analysis was performed using the SEEP/W module of GeoStudio 2012 (Ver. 8.14.1.10087, as published by GEO-SLOPE International) to create a two-dimensional, finite element model. Steady-state conditions

were assumed, with a piezometric surface fully developed in the embankment for the given water surface. This approach is representative for normal pool elevations, but is conservative for surcharge pools (particularly those above the auxillary spillway level). These results are also applied to the slope stability analysis. Soil parameters for the analyses were selected based on a review of the available geotechnical data, published correlations (based on classification and index properties), engineering judgment, and experience with similar materials. The parameter selection process is detailed in Volume 3 of the Geotechnical Investigation Report.

The results are summarized in Table 5-1:. Refer to Volume 3 of the Geotechnical Investigation Report for the detailed analysis and results for all eight sections.

Table 5-1: Steady State Seepage Summary

Station	Pool Level	Uplift Safety Index		Vertical Exit Gradient	Seepage Severity Category
		Effective	Total		
19+00	Normal Pool	>5	2.0	N/A	Negligible
	100-yr Flood	>5	2.0	N/A	Negligible
	500-yr Flood	>5	2.0	N/A	Negligible
	PMF	>5	1.9	N/A	Negligible
24+00	Normal Pool	N/A	N/A	N/A	Negligible
	100-yr Flood	N/A	N/A	N/A	Negligible
	500-yr Flood	N/A	N/A	N/A	Negligible
	PMF	N/A	N/A	N/A	Negligible
58+00	Normal Pool	>5	3.6	N/A	Negligible
	100-yr Flood	>5	3.5	N/A	Negligible
	500-yr Flood	>5	3.5	N/A	Negligible
	PMF	>5	3.4	N/A	Negligible
58+01	Normal Pool	>5	1.8	N/A	Negligible
	100-yr Flood	>5	1.7	N/A	Negligible
	500-yr Flood	>5	1.7	N/A	Negligible
	PMF	4.4	1.6	N/A	Negligible
78+00	Normal Pool	N/A	N/A	N/A	Negligible
	100-yr Flood	N/A	N/A	N/A	Negligible
	500-yr Flood	N/A	N/A	N/A	Negligible
	PMF	N/A	N/A	N/A	Negligible
98+00	Normal Pool	N/A	N/A	N/A	Negligible
	100-yr Flood	N/A	N/A	N/A	Negligible
	500-yr Flood	N/A	N/A	N/A	Negligible
	PMF	N/A	N/A	N/A	Negligible

106+00	Normal Pool	N/A	N/A	0.05	Negligible
	100-yr Flood	N/A	N/A	0.06	Negligible
	500-yr Flood	N/A	N/A	0.06	Negligible
	PMF	N/A	N/A	0.07	Negligible
108+00	Normal Pool	N/A	N/A	0.02	Negligible
	100-yr Flood	N/A	N/A	0.02	Negligible
	500-yr Flood	N/A	N/A	0.03	Negligible
	PMF	N/A	N/A	0.03	Negligible

To evaluate potential heave, the exit gradient was calculated beneath the downstream toe, at either the bottom of the overlying clay blanket or one-foot below the ground surface. In all cases where heave potential is present, the exit gradient is acceptable. The potential for uplift and blowout of clay blankets is not considered likely given their thickness, but was analyzed. The calculated safety factors against uplift are considered acceptable given the thickness of the blanket. The analysis also considered the potential for backward erosion piping of the foundation subgrade. The risk of piping generally applies only to cases where a continuous layer of erodible material is present but has enough cohesion to form a roof or is just below a cohesive/cemented material that can form a roof. In general, the analyzed sections are not susceptible to this failure mechanism, and the calculated seepage severity indicates that flux levels are negligible.

5.5.2 Slope Stability

A slope stability analysis is desired to confirm the stability of the embankment under the various reservoir loads and seepage forces. The slope stability analysis was performed by creating two-dimensional models from the cross sections, discussed above, using the SLOPE/W module within GeoStudio 2012 (Version 8.15.1 published by GEO-SLOPE International Ltd.). The program generates a variety of circles and slices for potential failure surfaces based on a user defined range of entry and exit points along the embankment surface. The safety factor is then calculated using a limit equilibrium method (LEM). For this project, the LEM analysis used Spencer's Method of Slices, which provides for moment equilibrium of each slice. The failure surfaces were "optimized" within the program to account for critical failure geometries that may not conform to an idealized circular shape.

Soil parameters for the analyses were selected based on the parameter selection process detailed in the “Material Parameters Selection of Soils for Settlement, Seepage and Slope Stability Analysis”, as provided in Volume 3 of the Geotechnical Investigation Report.

The study analyzed the stability associated with the end-of-construction (short-term), steady-state (long-term), and rapid-drawdown (short-term) loading conditions. These loading conditions and the slope analyzed is as presented below:

- End-of-construction (unconsolidated-undrained (UU) loading condition)
 - Upstream slope
 - Downstream slope
- Steady-state seepage (consolidated-drained (CD) loading condition)
 - Normal water surface, downstream slope
 - 100-year flood, downstream slope
 - 500-year flood, downstream slope
 - PMF, downstream slope
- Rapid drawdown (consolidated-undrained (CU) loading condition)
 - Normal water surface to Elev. 512 feet-msl, upstream slope
 - 100-year flood level to normal pool, upstream slope
 - 500-year flood level to normal pool, upstream slope
 - PMF level to normal pool, upstream slope

For the steady-state seepage (SSS) cases, the pore water pressure regime was imported from the “parent” seepage model for the section and pool level under consideration. For the rapid drawdown (RDD) analyses, two piezometric lines were drawn to represent the phreatic water surface for the maximum and minimum pool under consideration. The RDD approach assumes steady-state conditions develop, regardless of the pool duration, and uses the “three-stage” method to evaluate the safety factor from the minimum combination of the effective and total shear strength values (based on guidance given by Duncan, Wright and Wong (1990)). Note that the drawdown for surcharge pools only considers drawdown to the normal pool due to the use

of an uncontrolled spillway system. For drawdown from the normal pool, the drawdown is to Elev. 525 feet-msl, which corresponds to an arbitrary gate level at the intake tower.

Dam structures in the State of Texas must meet the stability requirements published by the TCEQ in Chapter 3.0 of *Design and Construction Guidelines for Dams in Texas, RG-473 (Aug. 2009)*. Although it does not govern the analysis, consideration is also given to guidance provided by the United States Army Corps of Engineers (USACE) *Slope Stability Engineering Manual EM 1110-2-1902 (Oct. 2003)*. A summary of these minimum requirements is provided in Table 5-2:.

Table 5-2: Slope Stability Requirements

Loading Condition	Slope Location	TCEQ Min. Safety Factor	USACE Min. Safety Factor
End-of-construction	Upstream and Downstream	1.25	1.3
Steady-state seepage, normal storage pool	Upstream	1.5	---
Steady-state seepage, normal storage pool	Downstream	1.5	1.5
Rapid Drawdown, from storage pool	Upstream	1.2	1.3
Rapid Drawdown, from maximum surcharge pool	Upstream	---	1.1

The results of the analysis are summarized in Table 5-3:. Refer to Appendix D for representative figures from the steady-state analysis from Station 78+00.

Table 5-3: Slope Stability Summary

Station	Water Surface Level (Elev.)	FACTOR OF SAFETY				
		STEADY STATE		RAPID DRAWDOWN	END OF CONSTRUCTION	
		Upstream	Upstream	Downstream	Upstream	Downstream
19+00	NWS (534 ft-msl)	2.0	2.4	1.9	3.2	3.6
	100-yr (540 ft-msl)	2.0	2.4	1.8		
	500-yr (542 ft-msl)	2.1	2.4	1.7		
	PMF (550 ft-msl)	2.8	2.4	1.5		
28+00	NWS (534 ft-msl)	1.9	2.2	1.7	2.9	3.2
	100-yr (540 ft-msl)	2.1	2.0	1.7		
	500-yr (542 ft-msl)	2.2	2.0	1.7		
	PMF (550 ft-msl)	2.9	1.8	1.5		
58+00	NWS (534 ft-msl)	1.9	1.7	1.3	1.7	1.8
	100-yr (540 ft-msl)	2.2	1.7	1.7		
	500-yr (542 ft-msl)	2.3	1.7	1.7		
	PMF (550 ft-msl)	2.6	1.7	1.6		

58+01	NWS (534 ft-msl)	2.1	1.6	1.3	1.8	1.9
	100-yr (540 ft-msl)	2.3	1.6	1.7		
	500-yr (542 ft-msl)	2.4	1.6	1.7		
	PMF (550 ft-msl)	2.8	1.6	1.5		
78+00	NWS (534 ft-msl)	2.2	1.6	1.3	1.3	1.3
	100-yr (540 ft-msl)	2.5	1.5	1.7		
	500-yr (542 ft-msl)	2.6	1.5	1.7		
	PMF (550 ft-msl)	2.9	1.5	1.5		
98+00	NWS (534 ft-msl)	2.1	1.6	1.3	1.4	1.4
	100-yr (540 ft-msl)	2.3	1.6	1.7		
	500-yr (542 ft-msl)	2.4	1.6	1.7		
	PMF (550 ft-msl)	2.6	1.6	1.5		
106+00	NWS (534 ft-msl)	2.0	1.6	1.3	1.7	1.6
	100-yr (540 ft-msl)	2.2	1.6	1.7		
	500-yr (542 ft-msl)	2.2	1.6	1.7		
	PMF (550 ft-msl)	2.5	1.6	1.5		
108+00	NWS (534 ft-msl)	2.1	1.9	1.3	2.1	2.9
	100-yr (540 ft-msl)	2.5	1.9	1.7		
	500-yr (542 ft-msl)	2.6	1.9	1.6		
	PMF (550 ft-msl)	3.3	1.9	1.5		

The results of the analysis indicate that the embankment meets the minimum slope stability requirements defined by TCEQ and USACE for embankment dams.

5.5.3 Settlement

Settlement is a significant design and maintenance consideration for the proposed embankment due to the dam height, the presence of compressible clay foundation, and the use of fat (CH) clays throughout a large portion of the proposed embankment section. Settlement will occur through a variety of mechanisms, including initial (elastic) settlement and consolidation (primary and secondary) of the foundation, and through hydro-compaction of the embankment fill material. The total settlement is of particular interest, but the time for settlement to occur must be considered for potential construction holds to limit excessive pore-pressure, and soil-structure interaction locations (such as intake tower).

Expansive soil movements will also occur, and should be considered. Refer to the following section addressing issues related to fat clays for this discussion. It is recognized that some elastic settlement will occur in the bedrock, but that it will be small relative to the other settlement

mechanisms and the majority of the settlement will be elastic and occur quickly. Settlement can also occur in response to earthquake loads, and the analysis of this mechanism is discussed in the following seismic section.

The potential settlement for the various mechanism was calculated along the dam centerline at each of the 15 centerline borings located within the floodplain (between approximate Stations 65+00 and 95+00). The analysis assumes an embankment height of 75 feet and that the underlying "bedrock" provides the lower boundary for potential settlement. Soil parameters for the analyses were selected based on a review of the available geotechnical data, published correlations (based on classification and index properties), engineering judgment, and experience with similar materials.

The parameter selection process and results of the following settlement analyses is detailed in Volume 3 of the Geotechnical Investigation Report. The following subsections discuss the Preliminary Design analysis results for each of the settlement mechanisms.

A. Elastic (Initial) Settlement

Elastic settlement is a settlement mechanism that occurs due to particle reorganization or deformation in response to loads. This mechanism is relatively quick and is typically accounted for in bulking and shrinkage factors used in the earthwork estimations. Because the embankment height is significant in the valley and the valley is wide, it is desirable to quantify this type of settlement so that appropriate adjustments can be made to earthwork quantity factors during subsequent design efforts.

Elastic settlement of the foundation soil was calculated using the Improved Janbu Method for cohesive soils, as outlined in the USACE settlement manual (EM 1110-1-1904). The elastic settlement calculation is dependent on total stress shear strength values, which were estimated from available field and laboratory data. The results from these elastic settlement calculations are summarized in Table 5-4:, and indicate that the calculated elastic settlement using the method is generally less than about 8 inches for most areas, but could potentially be as much as 12 inches.

The elastic settlement of the foundation and the embankment was also evaluated using a two-dimensional, finite element model using the SIGMA/W 2012 module within GeoStudio 2012 (Version 8.15.1 published by GEO-SLOPE International Ltd.). The cross sections previously discussed were analyzed. The element mesh was generated by the program using quadrilateral elements for each region, except that triangular elements are generated when necessary to provide smoother transitions and to ensure shape quality. A 10-foot global element size was selected to balance computation time and the resolution of the generated results. The analysis was performed in steps for the following stress levels:

- The initial, in-situ stress state
- The end-of-construction state (assumes embankment is instantly constructed)
- The reservoir instantly inundated to the normal pool level (Elevation 534 feet-msl).

The maximum calculated elastic settlement from the crest is about 14 inches using this analysis method (includes both foundation and embankment). When subtracting the initial foundation settlement, this results in approximately 2 to 6 inches of elastic settlement within the embankment.

B. Consolidation Settlement

Consolidation settlement is a mechanism that occurs in slow-draining, fine-grained soils that develop excess pore water pressures in response to load. This mechanism is relatively slow and can take months to years to fully develop. Because the embankment height is significant in the valley and the valley is wide, it is desirable to quantify this type of settlement to estimate the amount of over-build required to maintain the embankment crest free-board.

The majority of the consolidation settlement will be related to primary consolidation, but some additional long-term settlement will also occur due to secondary mechanisms. Primary consolidation of the foundation soil was calculated using classical consolidation theory, as outlined in the USACE settlement manual (EM 1110-1-1904). The consolidation was calculated to the 99 percent level and assumes saturation to the existing ground surface. Secondary consolidation was estimated using general relationships based on the primary consolidation results. The consolidation settlements are summarized in Table 5-4:, and

indicate that the calculated consolidation of the foundation varies from 12 to 25 inches. The time to 99 percent consolidation varies from one-half year to about 35 years, with a few cases that exceed 35 years. Based on experience, it is expected that the actual consolidation time will be less than predicted by classical soil theory. Secondary consolidation is estimated to vary from about 1 to 5 percent of the total consolidation and should be expected to take many decades to fully develop. Based on experience, we expect that approximately 50 percent of the primary consolidation will occur during construction (based on a construction duration of about two years). The consolidation and time estimated for this Preliminary Design analysis are approximate, and will be calculated using site specific consolidation test data for the Final Design analysis and report.

C. Fill Compression

Embankment fills for dams are placed at specified moisture and compaction levels to limit settlement and to allow for quality earthwork operations. However, experience indicates that post-construction settlement of the fill will still occur due to particle reorganization and compression of voids due to gravity and also when inundated with water. This mechanism occurs while the soil is in a partially saturated condition and can be described as compression, and is a prevalent issue in embankments composed of fat clays.

Because of the number of variables involved, it is difficult to quantify compression. Experience indicates that clay embankments can settle up to 2 percent of the embankment height when adequately compacted, and that about half of this settlement occurs within one-year of construction completion, and that the majority of remaining settlement occurs within five years following construction. Guidance provided by Fell et al in "Geotechnical Engineering of Dams (2005)" indicates that this type of compression settlement of clay embankments can be estimated using the relationship $0.179H^{0.60}$ during construction (where H is the embankment height and the product is in %H). For the maximum dam height, this results in approximately 2.4 percent settlement. It is worth noting that the relationship does not appear to differentiate compression settlement and elastic settlement or elastic settlement of the foundation. Fell et al also indicates that post-construction compression settlement varies from 0.001H to 0.01H after 10 years, and 0.005H to 0.01H after 25 years. These relationships result in approximately 22 inches of construction compression (and elastic) settlement, and up to 9 inches of post-construction settlement within 25 years.

D. Settlement Summary

This Preliminary Design analysis indicates that significant settlement will occur during the course of construction, and that appreciable settlement will continue once construction is complete. Table 5-4: summarizes the estimated settlement for the foundation and embankment fill within the valley section (approximately Station 55+00 to 105+00).

Table 5-4: Valley Section Settlement Summary for Preliminary Design Analysis

Time Increment	Settlement Type	Clay Foundation	From Crest of Embankment
During Construction	Primary Consolidation:	9 inches	N/A
	Elastic/Initial Settlement:	8 inches	22 inches
	Compression	N/A	
	<i>Total Construction Settlement:</i>		<i>31 inches*</i>
Post-construction	Compression:	N/A	9 inches
	Primary Consolidation:	9 inches	N/A
	Secondary Consolidation:	2 inches	N/A
	<i>Total post-construction Settlement:</i>		<i>20 inches</i>

* Elastic settlement of the foundation is included in the embankment crest settlement

This analysis confirms that earthwork quantities should account for shrinkage during placement, and that significant settlement will occur following construction and should be accounted for in the crest overbuild.

5.6 SEISMIC CONSIDERATIONS

5.6.1 Seismicity

As described in Chapter 3 peak horizontal ground accelerations are estimated at 0.05g to 0.08g along the base, but could potentially be amplified to 0.19g to 0.27g at the crest. The likely earthquake magnitude associated with this response is in the range of 4.8 to about 6.1. These peak ground accelerations can be factored using a horizontal seismic coefficient (k_h) when used in pseudo-static slope stability analyses. A horizontal seismic coefficient of 0.45 is selected for, which results in a factored horizontal acceleration of 0.1215g. This acceleration is relatively low and the analysis of the slope stability under this acceleration indicates that the embankment meets the seismic stability requirements of TCEQ.

5.6.2 Liquefaction

The liquefaction potential was evaluated for foundation beneath the proposed embankment. Soils considered potentially liquefiable included sandy soils with an equivalent clean sand blow count lower than 30 blow per foot and with a low fines content and low plasticity index. A factor of safety greater than 1.5 was determined for all identified locations except three, and this is considered sufficient to protect against liquefaction. Since there were factors of safety lower than 1.5 identified in three locations, the potentially liquefiable soils were also evaluated for potential ground settlement caused by a 5.5 magnitude earthquake. Potential ground settlement prior to construction of the embankment was 0.5 inches or less and after construction the estimated ground settlement was 0.6 inches or less. In addition, all these locations are located near the northwest end of the embankment, along the normal pool level where no permanent impoundment against the embankment will occur. As such, no overbuild for liquefaction is considered necessary.

5.7 INTERNAL FILTER AND DRAINAGE

Conceptual Design associated with the permit applications accounted for the inclusion of a chimney drain and horizontal finger drains below the embankment. The results of the seepage stability analysis indicate that a blanket drain is required for the control of seepage in the valley sections. Based on the analysis, the following minimum filter and drainage system is selected:

- Continuous vertical chimney filter, 3 feet wide, from Station 4+00 to Station 112+48.
- Single-stage sand finger drains, 200-foot spacing, from Station 7+00 to 43+00 with gravity outfall drains at discharge vaults along the embankment toe.
- Two-stage, gravel and sand finger drains, 100-foot spacing, from Station 44+00 to 53+00. Finger drains gravity outfall into collection pipes and discharge to vaults along embankment toe
- Continuous chimney collector drain, 2 feet tall by 3 feet wide, from Station 44+00 to Station 111+48

- Continuous horizontal blanket drain, minimum 2 feet thick, from Station 54+00 to 109+00. This includes gravel finger drains on 100-foot spacing. Blanket and finger drains gravity outfall into collection pipes and discharge to vaults along the embankment toe.
- Continuous vertical chimney/diaphragm filter, 3 feet wide, from Station 103+60 to Station 110+70 that connects to gravity outfall integrated with intake piping

An analysis of the filter and drain requirements was performed for the proposed borrow area using the modified methodology presented by Foster and Fell (1999). The proposed borrow material is fine-grained lean to fat clays (analyzed in two groups, A and B) and the calculated fine filter and aggregate drain gradations are provided in Volume 3 of the Geotechnical Investigation Report, and are reproduced in Table 5-5:.

Table 5-5: Filter and Drain Gradation Analysis Results

Sieve	Group A				Group B			
	Fine Filter		Drain Material		Fine Filter		Drain Material	
	Min. Pass.	Max. Pass.	Min. Pass.	Max. Pass.	Min. Pass.	Max. Pass.	Min. Pass.	Max. Pass.
2.in.							100	
1.5 in.			100				95	
1 in.			90				85	
3/4 in.	100		80	100			75	100
3/8 in.	95		55	90	100		55	90
No. 4	90		35	70	85		35	70
No. 18	80	100	15	50	70	100	15	50
No. 16	65	85	5	30	50	85	5	30
No. 30	45	65	3	10	30	65		10
No. 50	25	45		5	10	45		7
No. 100	5	25			2	25		5
No. 200		5				5		3

Considering that the materials will be mixed by the mass earthwork operations, the results indicate that material conforming to ASTM C33 fine aggregate sand composed of rounded to sub-rounded, natural silica particles is appropriate.

5.8 SOIL CEMENT CONFIGURATION

The upstream slope of the embankment will be armored to provide protection from wave action. Dam embankments are typically armored with rock rip rap, but soil cement armoring is planned because potential rock sources are limited in the surrounding region. The soil cement will extend from the base of the embankment (or toe berm when present) to the crest of the embankment. The soil cement will be manufactured onsite from sands imported from nearby sources.

In order to determine the most appropriate soil cement design for Lower Bois d'Arc Creek Reservoir, a literature review was performed, as well as site visits to seven dams that have had various forms of soil cement slope protection in place for extended periods of time. In addition, recent inspection reports for dams with soil cement slope protection were reviewed. All dams evaluated were constructed at least 20 years ago. The intent of this investigation was to determine how soil cement has performed in the field under various conditions, and to draw any conclusions as to the most appropriate soil cement design for Lower Bois d'Arc Creek Reservoir. A technical memorandum, *Soil Cement Design for Lower Bois d'Arc Dam*, was developed documenting the research approach and findings of the literature review and site visits and was included in the Preliminary Design Report (2014) and is not repeated here.

There are two basic methods of soil cement placement: the stair-stepped method and the plating method. The stair-stepped method involves placement of the soil cement in horizontal lifts, typically eight to ten feet wide, and varying in thickness from six to 12 inches. The plating method involves placement of the soil cement parallel to the slope in one or multiple lifts, with lifts typically ranging in thickness from six to 12 inches.

Based on the research and evidence described in the Preliminary Design Report, the following general conclusions were reached.

- A. The stair-stepped soil cement appears to perform better than plated in areas exposed consistently to large waves. In addition, damage that does occur to portions of the stair-stepped soil cement appears to remain somewhat isolated, not necessarily affecting other portions of the soil cement. Damage of plated soil cement, on the

other hand, seems to propagate outward and affect a much larger portion of the soil cement.

- B. Repair of damage to stair-stepped soil cement, such as lost lifts, is relatively easy to complete due to the stair-stepped configuration. Placement of forms along the edge of a lift, and use of steel reinforcing and concrete provide a strong patch that generally performs well over time. Repair of damaged plated soil cement, in comparison, is more difficult to complete effectively.
- C. One of the major issues noted at dams with plated soil cement slope protection was separation and undermining at construction joints. This led, in some cases, to portions of the soil cement lift adjacent to the joint breaking off and sliding farther down on the slope. Once breakage like this begins to occur, there is less support for portions of the soil cement higher up on the slope, and more pieces begin to break off and slide to the bottom of the slope.
- D. The majority of the damage seen on slopes with stair-stepped soil cement is broken lifts caused by water infiltration between the lifts, and breaking off of upper lifts due to a reverse cantilever action. Based on field observations, as well as findings in other reports, it appears that this issue most commonly occurs when there is insufficient bond between successive lifts of soil cement. For this reason, a grout bonding agent will be used between all horizontal lifts between elevations 520 and 540 where most heavy wave action will occur.

In summary, it appears that both plated and stair-stepped soil cement provide adequate erosion protection of the upstream slope of embankment dams. Stair-stepped soil cement will be used from Station 44+00 to the right end on the taller portions of the dam where the fetch will be maximized across the reservoir. Each step will be a 12-inch, horizontally placed lift.

Plated soil cement will be used from Station 0+00 to 44+00, on portions of the dam that are not as tall and that are not subjected to large waves on a continuous basis. The plated soil cement will be placed in two, 12-inch thick lifts parallel to the slope face with a dry cement bonding agent placed between the lifts.

5.9 RECOMMENDED INSTRUMENTATION

The embankment and related structures for Lower Bois d'Arc Creek Reservoir will have a variety of geotechnical mechanisms that justify monitoring both during and after construction. Based on the stability analysis results, the following list summarizes the recommended instrumentation.

- Monitor pore pressures of foundation soil and embankment during fill placement
- Monitor settlement during and following construction of the:
 - Foundation soil
 - Embankment fill
- Monitor lateral bulging of the embankment slope during construction
- Monitor the intake tower and bridge structure for movement or tilting
- Long-term monitoring of pore pressures within the foundation soil
- Long-term monitoring of piezometric levels within the embankment fill
- Long-term monitoring of flow quantities from the embankment internal drainage system

Pore pressures should be measured with a combination of vibrating wire piezometers and open standpipe piezometers. The vibrating wire piezometers provide an automated means of collecting data during construction, upon first filling, and long term. These instruments allow for measurements to be taken in areas where vertical access is limited for a standpipe piezometer (upstream half of embankment). They also have a near instantaneous response time to pressure changes. The standpipe piezometers will serve as a redundant system in select areas to spot check the data reported from the vibrating wire piezometers. The standpipe piezometers will also be installed in areas that are likely to be unsaturated, as these conditions are not recommended for vibrating wire piezometers.

Deformations will be measured using surface monuments, settlement gauges, and inclinometers. Temporary and permanent surface monuments will allow for the collection of survey data during and after construction at discrete points along the dam. The survey points will provide ground surface spatial and elevation data. Settlement gauges will provide vertical deformation data for

the foundation material. Inclinerometers will provide data related to lateral movement within the embankment and foundation. The selection of the monitoring points should include several lines of temporary monuments along the slopes in the valley sections to monitor for potential bulging of the embankment slope during the settlement process. It is also necessary to collect weather data, such as barometric pressure, temperature and rainfall, as these values can influence behavior of the infrastructure and instrumentation.

Refer to Section B of the Contract Drawings for the proposed instrumentation layout.

5.10 SUMMARY OF EMBANKMENT CONFIGURATION

The following list summarizes the various components of the embankment system that were selected based on the analysis summarized in this section. Selected typical sections are shown in Figures 5-1, 5-2 and 5-3.

- Embankment Geometry:
 - Crest width of 20 feet, with crushed stone road surface
 - 3.5H:1V upstream and downstream slope ratios
 - The design embankment crest elevation will include up to an 18-inch overbuild to account for post-construction settlement (overbuild will vary proportionally with embankment height).
 - The upstream slope includes a 20-foot berm at Elevation 505 ft-msl (from approximate Station 54+50 to 108+00).
 - The downstream slope includes a 15-foot berm at Elevation 520 ft-msl (from approximate Station 56+00 to 106+00).
 - The downstream slope includes a 25-foot toe berm at Elevation 490 ft-msl through the valley section (approximate Station 56+00 to 106+00). The toe berm transitions with the topography along both the left and right terraces.
 - The downstream shell of the embankment will be constructed from primarily lean and fat clay materials excavated from onsite borrow areas.
 - The slurry cutoff trench was offset approximately 100 feet upstream of the centerline, and will be constructed from the top of Phase 1.

- Internal Drainage System:
 - Continuous vertical chimney filter, 3 feet wide, from Station 4+00 to Station 112+48.
 - Single-stage sand finger drains, 200-foot spacing, from Station 7+00 to 43+00. Finger drains gravity outfall at discharge vaults along embankment toe.
 - Two-stage, gravel and sand finger drains, 100-foot spacing, from Station 44+00 to 53+00. Finger drains gravity outfall into collection pipes and discharge to vaults along embankment toe
 - Continuous chimney collector drain, 2 feet tall by 3 feet wide, from Station 44+00 to Station 111+48
 - Continuous horizontal blanket drain, minimum 2 feet thick, from Station 54+00 to 109+00. Includes gravel finger drains on 100-foot spacing. Blanket and finger drains gravity outfall into collection pipes and discharge to vaults along embankment toe
 - Continuous vertical chimney/diaphragm filter, 3 feet wide, from Station 103+60 to Station 110+70. Connects to gravity outfall integrated with intake piping
- Upstream Soil Cement:
 - Two 12-inch lifts of plated soil cement on the upstream slope from Station 0+00 to 44+00.
 - Stair-stepped soil cement on the upstream slope from Elev. 505 feet-msl to Elev. 553 feet-msl from Station 44+00 to Service Spillway.
- Soil-Bentonite Cutoff:
 - A soil-bentonite slurry cutoff trench that is 3 feet wide, offset 10 feet upstream of centerline, and extends to the underlying bedrock from Station 4+00 to 57+30 and from 107+50 to 110+80.
 - Trench is offset 100 upstream of dam centerline from Station 57+30 to 107+50.

6.0 SERVICE SPILLWAY

6.1 BACKGROUND

The water rights application drawings proposed a traditional concrete ogee service spillway, chute and stilling basin which would have a discharge channel back to Honey Grove Creek, located downstream of Lower Bois d'Arc Creek Reservoir Dam. The ogee, chute, stilling basin and discharge channel would be 150 feet wide with a spillway crest elevation of 534 feet-msl.

Upon beginning the Preliminary Design, the service spillway configuration was re-evaluated. A labyrinth spillway was pursued due to the ability to reduce the overall footprint of the spillway while still maintaining sufficient discharge over the weir for frequent flood events. A labyrinth spillway, provides a greater overflow weir length at lower water surface elevations (depths) than a traditional ogee spillway. This provided numerous benefits, including the ability for frequent storm events to drain off faster, reducing the duration of time in which land adjacent to the lake would be inundated or flooded. The labyrinth spillway also reduced the spillway footprint from 150 feet wide to 60 feet wide, which resulted in a significant cost savings. This decreased width was used for the spillway, chute, stilling basin and discharge channel. The configuration also allowed for the incorporation into the spillway structure of large sluice gates to be used for the higher environmental flow releases required by the environmental permits. This reduced the size, cost, and complexity of the intake structure for the pump station.

The labyrinth spillway was designed to be fully aerated through the 100-year flood event, with the weir beginning to drown out above the 100-year peak elevation. This means that the effective length of the weir is reduced as the weir begins to be drowned out. This is not a hydraulic concern, but rather, provides a cost reduction, because the reduced discharge capacity of the service spillway above the 100-year event will be replaced through the emergency spillway, which is more cost effective to construct and maintain.

The original labyrinth configuration was developed by FNI to meet TCEQ flood capacity requirements. The design flood and the hydraulic design of the spillway configuration including

its discharge rating curve is described in the Preliminary Design Report (2014). These were provided to the Utah Water Research Laboratory (UWRL) at Utah State University, who conducted a model study on behalf of the Lower Bois d'Arc Creek Reservoir Dam project. The model study is documented in "*Lower Bois d'Arc Creek Dam Spillway Model Hydraulic Model Study Report*" (October 2014) developed by the UWRL, a copy of which is included in the Preliminary Design Report (2015).

The final labyrinth configuration was 60 feet wide with 3 weir cycles, each 20 feet wide, with a side angle of eight degrees. The length of the weir parallel to flow was 46.55 feet. This design provided an effective weir length of 292 feet. The crest elevation of the weir was maintained at 534 feet-msl. This is unchanged from the preliminary design which was part of the design storm determination that was reviewed and approved by TCEQ based on the Preliminary Design Report (2015).

The stilling basin including dissipation elements was analyzed by the UWRL and optimized during the model study. Of particular concern was ensuring that sufficient tailwater would be available for a fully formed hydraulic jump to occur and the reduction of erosive velocities prior to entering the channel downstream. The final configuration of the stilling basin provided a 125-foot long basin with a bottom elevation of 460 feet-msl. Two rows of baffle blocks were included to initiate the hydraulic jump. The training walls do not run the full length of the basin, and instead end at 85 feet into the basin. The remaining 40 feet does not have training walls, but forms the bottom of a trapezoidal channel with 3.5H:1V side slope. This allows the water to spread laterally prior to exiting the stilling basin which provided performance benefits in regard to the hydraulic jump and decreased velocities in the discharge channel. The discharge channel transitions from elevation 460 feet-msl to elevation 471 feet-msl at a 3.5H:1V slope 113.5 feet downstream of the end of the training walls effectively forming an end sill to the stilling basin. However this is not a structural component of the spillway, but a soil cement lined channel. The discharge channel then slopes to drain into the existing Honey Grove Creek at a slope of 0.25 percent.

The final configuration of the service spillway, chute, stilling basin and downstream channel are shown in Section C of the Contract Drawings.

6.2 APPROACH WALLS

The preliminary design included Roller Compacted Concrete (RCC) gravity sections on either side of the spillway to allow transition to the embankment section on the left and the abutment on the right. The Preliminary Design Report described a comparison of the two alternatives and recommended the RCC abutments. However, for cost purposes, the final design selected the use of large concrete retaining walls for the approach channel. The embankment will be placed directly against the back side of the approach walls. It was shown during the model study that the hydraulic performance of the spillway is not affected by either configuration.

Section C of the Contract Drawings shows the full spillway structure. A rendering of the structure is shown in Figures 6-1 and 6-2. A brief description of the structural design of the spillway is described in the following sections for each component of the spillway.

The structural design of the approach walls are in accordance with the following Corp of Engineering (COE) design manual:

- EM 1110-2-2502, 29 September 1989, "Retaining and Flood Walls"

The approach walls are cantilever cast-in-place concrete retaining walls and line the left and right side of the channel just upstream of the crest. The channel is 96'-0" wide at the top of the approach walls. The walls are 140'-0" long and vary 3.5H: 1V from 2'-0" tall at their most upstream point to 42'-0" tall where they connect to the outlet works structures. The approach walls consist of four 35'-0" long sections with a varying footing width. The left and right approach walls are tied together with compression struts located at 17'-6" intervals, two per wall section.

The approach walls were designed based on normal pool, 100-year, PMF, rapid draw down from PMF to 100-year elevations, and rapid draw down from 100-year to normal pool elevations. The design loads include uplift forces, soil loads, water loads, and the self-weight of the concrete. The uplift pressures were based on the water elevations at the heel and toe of the wall for each load

case considered. The uplift pressures were assumed to vary linearly from the uplift pressure at the heel to the uplift pressure at the toe. The soil loads were based on backfill parameters given by the geotechnical analysis.

6.3 CREST STRUCTURE AND LABYRINTH WEIR

The structural design of the crest structure and labyrinth weir is in accordance with the following Corp of Engineering (COE) design manual:

- EM 1110-2-2104, 20 August 2003, "Strength Design for Reinforced-Concrete Hydraulic Structures"
- EM 1110-2-2100, 1 December 2005, "Stability Analysis of Concrete Structures"
- EM 1110-2-2502, 29 September 1989, "Retaining and Flood Walls"

The crest structure consists of the left and right spillway outlets, the labyrinth weir wall, the abutment and downstream training walls and the slab and footing. The crest structure was designed for normal, 100-year, and PMF water levels. These water levels can be seen in Table 6-1. The interior width of the crest structure varies from 96 feet at the upstream edge sloping linearly to 60 feet wide downstream where the crest connects into the upper chute. The walls will be 42'-0" tall max and slope linearly to 33'-6" tall at STA 10+60 and then to 25'-8" tall at STA 11+20 where the spillway meets the upper chute. For specific dimensions of the crest structure, refer to drawing C-10.

Table 6-1: Spillway Crest Loads

Labyrinth Weir	PMF	100-year	Normal
Headwater Elev. (ft-msl)	550	540	534
Tailwater Elev. (ft-msl)	530	522	506
Uplift at Upstream Edge Elev. (ft-msl)	550	540	534
Uplift at Downstream Edge Elev. (ft-msl)	536.5	521.25	513

The COE requires the structure to be checked against sliding, floatation, rotation, and bearing. The crest was checked for the flood cases indicated above both with and without uplift. In all load cases the crest section is stable and meets the COE required factors of safety. For the bearing check the structure was conservatively assumed to bear directly on the rock beneath it. In areas

This page is a placeholder for information submitted with the application that may contain confidential information. Please contact Cindy DePrato, Executive Assistant at (512) 463-8420 to request reviewing this information.

with high compressive pressures, the load was spread out no more than two slab thickness away from the concentrated load.

6.3.1 Spillway Outlet Walls

The spillway outlet walls are located at the most upstream portion of the crest structure. The spillway outlets are two 42'-0" tall cast-in place structures on the east and west sides of the upstream portion of the crest structure and are located between STA 9+96.83 and STA 9+72. The side walls of the outlets are 4'-0" thick and the downstream wall is 3'-6" thick. The outermost wall on the outlets vary from 4'-0" thick at the top to 11'-6" thick at the base. The outlets were checked for stability per USACE EM1110-2-2100 and were checked for strength per ACI 318, ACI 350, and USACE EM1110-2-2104. The outlet works were designed based on normal pool, 100-year, PMF and rapid drawdown water surface elevations. Rapid drawdown load case is where the water level in the soil at the PMF water elevation while the water inside the spillway is at the 100-year water elevation due to the water trapped in the soil not draining as quickly as the water inside the spillway. The design loads include lateral hydraulic forces due to headwater and tail water, uplift forces due to headwater, soil loads outside of the spillway, self-weight of the concrete, and the weight of headwater on the slab. Uplift pressures were based on the headwater elevations of the crest. Torsion is induced in the outlet works walls when the stop logs are in place due to eccentric loading from the stop logs to the wall. The outlet walls and connection to the labyrinth weir walls and the abutment walls were checked to account for these loads.

The outlets were checked for floatation for the controlling load case of when the stop logs are in place and the outlet works is dewatered using the COE safety factors. The outlets were checked for overturning using the normal pool, 100-year, and PMF water elevations. In all three load cases, the base of the outlet works remained 100% in compression meeting the COE requirements for overturning.

6.3.2 Labyrinth Weir Walls

The labyrinth weir walls are located near the upstream portion of the crest between and just downstream of the outlet structures. There are 3 apexes upstream and downstream consisting of walls that are 23'-0" tall and 2'-0" thick. The interior of the apexes are filled solid with concrete 10'-0" from the apex. The strength design of the walls is in accordance with ACI 318, ACI 350 and USACE EM1110-2-2104 "Strength Design for Reinforced-Concrete Hydraulic Structures". The walls were designed based on normal pool, 100-year, and PMF headwater and tailwater elevations.

The PMF load condition controlled in the design of the labyrinth weir wall. Based on the Physical Model Study of the PMF load condition, the headwater elevation upstream of the weir is 550 feet-msl and the tailwater elevation immediately downstream of the weir is 532 feet-msl. The water elevation drops immediately after the weir, there is no transition assumed between the two levels. In the calculation of the tailwater pressure, the unit weight of water is assumed to be $(0.6) \times (\text{unit weight of water})$ due to aeration of the water.

6.3.3 Abutment and Training Walls

The abutment and training walls are cantilever cast-in-place concrete retaining walls with a continuous slab in between. Near the outlet structures the wall acts more like a two way wall and was designed as such. The walls were designed based on normal pool, 100-year, and PMF water elevations. The design loads include uplift forces, soil loads, water loads, and the self-weight of the concrete. The soil loads were based on backfill parameters given by the geotechnical analysis. The loading on the walls is in accordance with EM 1110-2-2502, 29 September 1989, "Retaining and Flood Walls" and the strength design is in accordance EM1110-2-2104 "Strength Design for Reinforced-Concrete Hydraulic Structures".

6.4 UPPER CHUTE STRUCTURE

The structural design of the chute is in accordance with the following Corp of Engineering (COE) design manual:

- EM 1110-2-2104, 20 August 2003, "Strength Design for Reinforced-Concrete Hydraulic Structures"
- EM 1110-2-2100, 1 December 2005, "Stability Analysis of Concrete Structures"

The spillway chute is located between STA 11+20 and STA 15+60. The chute is 60'-0" wide at the top of the walls, which vary from 25'-8" tall to 15'-0" tall. The chute was designed for normal, 100-year, and PMF water levels. Normal water levels assumed no water flow in the chute. Based on the Physical Model Study of the PMF load condition, the outside water elevation is assumed to be 500 feet-msl. The PMF water elevation inside the chute is to the top of the chute walls, but no higher than elevation 530 feet-msl. For the section located between the lower portion of the chute and the stilling basin a straight line is taken from where the water profile begins to drop down to the front of the baffle blocks, where the water elevation is assumed to be 5 feet for the PMF condition. The soil elevation on the backside of the walls can be seen on sheet C-10. The soil elevation is typically 3'-6" below the top of the wall. At the upper portion of the chute, the soil is 17'-0" above the footing elevation. The PMF load condition controlled the design of the chute wall inside reinforcing and the normal load condition controlled the design of the chute wall outside reinforcing. For the wall design the drains behind the walls were ignored and the soil was assumed to be inundated for the normal pool load case. For the slab design and the uplift check of the chute section the drains behind the wall were assumed to be 50% effective.

6.5 LOWER CHUTE AND STILLING BASIN STRUCTURE

The structural design of the lower chute and stilling basin is in accordance with the following Corp of Engineering (COE) design manual:

- EM 1110-2-2104, 20 August 2003, "Strength Design for Reinforced-Concrete Hydraulic Structures"
- EM 1110-2-2100, 1 December 2005, "Stability Analysis of Concrete Structures"

The stilling basin structure is a USBR type basin that contains a sloped spillway chute, flat basin slab, and baffle blocks. The 4H:1V spillway chute starts at Station 15+35 and extends to a joint at Station 16+60. The joint transitions from the spillway chute to the basin slab. The basin slab continues from Station 16+60 and extends to Station 17+85. The concrete thickness in the

spillway chute varies from 3 feet at Station 15+35 to 5 feet at Station 16+60. The basin slab has a constant thickness of 5 feet. The stilling basin interior flow width is 60 feet and the exterior concrete width is 74 feet. The training walls vary in height from 15 feet along the spillway chute to 40 feet tall in the basin.

The stilling basin was designed based on normal pool, 100-year, 500-year, and PMF water surface elevations. The design loads include uplift forces due to tailwater, self-weight of the concrete, and weight of hydraulic flow over the basin. Uplift pressures were based on the tailwater in the stilling basin and varied based on the base elevation of the structure. The flow depths along the chute were approximated based on the Physical Model Study results. The flow depths entering the basin were documented for the 100-year and PMF events. The hydraulic jump was approximated as a linear transition from the upstream baffle blocks to a point 30 feet upstream from the end of the basin walls. This is based on the performance of the hydraulic jump in the physical model study. Tailwater pressure must be adjusted for retrogression and the reduction in pressure can be as much as 40 percent. Therefore the unit weight of water in the hydraulic jump zone was multiplied by 0.6. A summary of these water surface elevations is presented in Table 6-2.

Table 6-2: Stilling Basin Design Criteria

Stilling Basin Walls	PMF	500-year	100-year	Normal
Tailwater Elev. (ft-msl)	496.5	478	478	471
Elev. Before Jump (ft-msl)	465	463	463	N/A
Elev. After Jump (ft-msl)	496.5	478	478	N/A
Uplift Elev. (ft-msl)	496.5	478	478	471
Hydraulic Jump End Station	17+15	16+95	16+90	N/A

During preliminary design, it was determined that the stilling basin was stable for all flood events except the PMF. In order to stabilize the basin for the PMF, two options were proposed. The first option was to increase the thickness of the chute and basin slab to meet required factors of safety. The second option was to add rock anchors that would engage during the PMF event. Rock anchors were determined to be the more cost-effective solution. A finite-element model

was constructed to determine the required rock anchor forces and design forces in the concrete chute and basin. Rock anchors will be installed on 10-foot centers in the chute starting at Station 15+85 and extending to the basin to Station 17+15.

6.6 TRASH BOOM

Debris control will be an important component of the operation and maintenance of the Lower Bois d'Arc Creek Reservoir Dam and appurtenant structures, especially the service spillway and the pump station intake structure. Natural and manmade debris that migrates to these structures can cause clogging or obstruction of screens and trashracks thus reducing the capacity of these components. Large debris can be caught in turbulent spillway discharges and cause damage to the structure itself, or appurtenant operational equipment. The first line of defense against floating debris is a boom designed to deflect or retain said debris before it reaches screens, trashracks, or overflow weirs.

Debris loading in a water body is primarily driven by storm events which increase velocities and water levels along the banks of the water body. In particular this applies to incoming streams into the reservoir, and not the reservoir itself. The types of debris that are washed loose during storm events can vary from natural debris such as whole trees to manmade debris such as boat docks as well as loose debris that people dispose of in the watercourse. The Lower Bois d'Arc Creek Reservoir will likely have a moderate amount of debris accumulation following the first filling when much of the reservoir area is transitioning from naturally dry land to inundation reservoir area, but following this time period, the reservoir debris load should be relatively light.

Debris transport is a function of current and prevailing wind direction, the latter being more important in the case of the Lower Bois d'Arc Creek Reservoir since the flow rates will be minimal relative to the cross sectional area of the reservoir. The prevailing wind direction is primarily out of the south except during the winter months when the prevailing wind direction is approximately equally from the north and the south. The winds coming out of the south are most likely to cause debris to accumulate along the embankment of the dam near station 45+00, but

it is possible that some debris is accumulated near the service spillway inlet channel and near the pump station intake structure.

Manufactured debris boom systems typically consists of UV resistant polyethylene booms or buoys filled with closed cell foam to create “unsinkable” capsules. These booms are connected together with steel or galvanized steel structural shapes, chains, wire ropes, and/or shackles. The structural components of the debris boom provides the desired strength to retain the debris load. The debris boom can be fitted with hanging screens to increase their effectiveness in retaining debris, and can be fitted with maintenance walkways for accessing the boom to remove debris periodically. In addition to retaining debris, the debris boom can incorporate boater safety components such as high visibility buoys and lighted buoys, and can restrict boat access to areas of the reservoir. A common debris boom system is the TuffBoom system manufactured by Worthington Waterway Barriers, but many manufacturers are available.

The design consisted of developing the configuration of the debris control system. The final configuration is shown as Section C for the spillway and Section D for the intake structure of the Contract Drawings. The debris boom for the service spillway will be anchored to the left side of the service spillway approach channel approximately 150 feet upstream of the labyrinth weir. From this point the boom will angle towards the south east and will be anchored to the right side of the approach channel approximately 300 feet upstream of the labyrinth weir. This configuration should help to divert debris along the boom towards the left side of the channel where it can be reached from the shoreline. The total length of the debris boom will be approximately 350 feet and will provide for variation in the water surface for any elevation below 544 feet-msl, 10 feet above normal pool. The debris boom system will incorporate the hanging screen and maintenance walkways.

6.7 STOP LOGS AND TRASH SCREENS

The two spillway outlets located on each side of the labyrinth weir will be constructed with three sets of slots to be utilized for installation of trash screens and stoplogs in the upstream reach of the outlet works. Trash screens will be installed just upstream of the outlet slide gates to protect

the outlet gates from debris. The trash screens are expected to remain in place at all times. The screens will extend from El 511 to El. 553 (PMF) which is the top of the wall at the outlet works. The trash screens will be removed for cleaning whenever necessary. There will be two sets of stop logs which can be installed immediately upstream of the trash screens whenever maintenance operations are needed at the outlet works.

The trash screens will be approximately 15'-5" wide and 6'-0" tall. This size will allow for easy handling and transport by the District within the confines of the dam structures. The trash screens will be built from 316 stainless steel to minimize corrosion due to their extended submersion. The trash screens will be stacked seven high to reach from the apron floor to the PMF level. Each screen will be identical and can be stacked in any order. The screens will be lifted by the same lifting beam which handles the stop logs.

The stop logs will be 15'-5" wide and 6'-0" tall. The stop logs will be built from A-36 and A-50 grade steels. Corrosion protection will be a high performance coating rather than stainless steel due to the stop logs' intermittent service. The stop logs will be installed from El. 511 to El. 541 when needed for maintenance at the outlet works. There will be two sets installed, one in front of the other to provide additional safety to the maintenance personnel. The stop logs will all be identical and stackable in any order. The stop logs will be designed in accordance with AISC 360-10 and AISC Steel Design Guide 27 as applicable and for a maximum head of 30 feet. Rubber seals will be provided on the downstream faces and at the bottom of all logs to allow the logs to seal against the embedded stop log guide, bottom seal plate, and upon one another. They will be handled by a portable crane and a lifting beam which travels in the slots. All slots will have stainless steel embeds and provide sealing surfaces for all rubber seals.

The labyrinth spillway will be protected from debris accumulation by installing trash screens immediately upstream of the labyrinth weir. The trash screens will be installed in slots formed in the sidewalls of the concrete approach structure. The slots will consist of stainless steel embeds cast into second stage grout in the vertical wall faces and along the bottom sill plate.

7.0 INTAKE STRUCTURE AND CONDUITS

7.1 BACKGROUND INFORMATION

A previous study completed by Freese and Nichols, Inc., "Lake Pump Station Alternative Analysis Report" dated May 2014 identified an intake tower as part of the Lower Bois d'Arc Creek Reservoir dam and a horizontal pump station located downstream of the proposed dam as the recommended layout for the raw water intake and pumping system. A more detailed review of the intake tower siting near the dam infrastructure was undertaken as part of a separate project for the NTMWD. This separate project also involved issues with the pump station and electrical substation siting. Separate deliverables included a memorandum report describing the final siting and configuration recommendations for the intake, pump station and support facilities and a preliminary design report for the recommended alternatives.

The previous studies mentioned above also established intake tower size/capacity, overall elevations, tower arrangements, and gate sizes and positions.

7.2 INTAKE TOWER

The intake tower, shown as an isometric in Figure 7-1, is divided into two main sections: west half and east half. Each section is further subdivided into three subsections: the entrance area, outer chamber, and inner chamber. The west half and east half inner chambers have the ability to be hydraulically connected or separated by the use of a double gate, but all other west subsections are isolated from all other east subsections and vice versa. The tower invert in the entrance area and outer chamber areas is 467.0 feet-msl, and at the inner chamber the invert approximately 462.0 feet-msl. The top of the tower is 553.0 feet-msl, which is 3ft above the PMF elevation of 550.0 ft-msl. This configuration was developed to allow the tower to have less than 1 fps entrance velocity at all times to meet new 316B regulations from EPA. This criteria, combining screens with openings of less than 1 square inch and velocities of less than 1 fps to prevent fish entrainment required the separation of the screens from the individual grates.

All water entering the intake tower must first pass through either the west or east entrance areas which are located on the south side of the intake structure. Each entrance area has three sets of

This page is a placeholder for information submitted with the application that may contain confidential information. Please contact Cindy DePrato, Executive Assistant at (512) 463-8420 to request reviewing this information.

vertical stop logs slots. The first two upstream slots are reserved for stop logs. The third, farthest downstream slot is reserved for the intake tower screens. The two stop log slots are provided as required by the Owner so that two sets of stop logs can be used at any one time. Double stop logs serves as a redundant system in the event that maintenance work is required inside either the outer or inner chambers. Screens and stop logs are discussed in Section 7.3.

Water flowing through the entrance area enters the outer chamber. The outer chamber functions to protect gates from being silted, allows servicing of inner chamber gates if required, and maintains water access to the inner chamber on two sides. Each inner chamber has four gates that hydraulically connect it to its respective outer chamber. Water inside each inner chamber discharges unhindered into an ungated pipe – one pipe of the pump station intake conduit.

Near the top of the tower, additional stop log slots are provided as storage for temporary stop logs. The bottom of the log storage slots is approximately 30-inches above the normal pool elevation.

At the top of the tower, over each entrance area, stop log storage, and gate locations, galvanized bar grating is provided. The bar grating is removable and will provide a continuous, flat walking surface at the top of the intake tower while still allowing for access into each area/chamber for any maintenance or operational needs. When access into the tower is required, prior to removal of grating a portable, four-sided, single unit guard will be installed around the grating area to be removed.

A bridge crane support frame will be attached to the top of the intake tower to provide support for a bridge crane. All support framing will be fabricated from galvanized steel. The bridge crane will be rated for out-of-door use and have a pay load capacity sufficient to lift stop logs, screens, man-baskets, and gates. Additionally the bridge crane can be used to move portable guards and lift sections of grating as required.

item being lifted	item weight (lbs)	net bridge crane payload capacity (payload less lifting beam & rigging)
7'-6" high stop log	9,400	16,670 lbs
7'-6" high screen	1,200	
7'-6" high screen with mussels (assumed 40 psf)	9,100	
7'x7' gate	3,200	
note: lifting beam and rigging assumed to be 3,300 lbs		

Two ventilated masonry buildings will be provided at the top of the intake tower to provide protection for electrical equipment and provide a miscellaneous storage space.

The intake tower foundation subgrade will be limestone and/or lean concrete that is founded on limestone. A mud slab will be installed below required bottom of foundation in order to protect exposed subgrade and prevent weathering. An approach slab and walls leading up to the intake tower will align with the upstream diversion channel and provide scour protection in front of the intake tower foundation, a hard surface for dredging operations, and restraint of side slopes.

The reinforced concrete portions of the intake tower will be designed in accordance with the American Concrete Institute, "Code Requirements for Environmental Engineering Concrete Structures and Commentary" (ACI 350-06).

Structural steel portions of the intake tower will be designed in accordance with the American Institute of Steel Construction, Steel Construction Manual 14th edition, "Specification for Structural Steel Buildings" (AISC 360-10).

Concrete masonry buildings will be designed in accordance with Masonry Standards Joint Committee "Building Code Requirements for Masonry Structures" (ACI 530-11).

7.3 SCREENS AND STOP LOGS

All water will be screened prior to entering the intake tower chambers. One screen will be provided in each intake tower entrance channel. Each screen will be subdivided into eleven individual, vertically stacked, 7'-6" high segments, and each screen segment will be fitted with

lifting lugs on top and lug slots on the bottom. This configuration and components will facilitate screen removal and cleaning operations. Top of the screens is at 549.5 feet-msl. During PMF condition, the screens will be overtopped by 6-inches. All other unusual and extreme water level conditions will be screened.

316 stainless steel expanded metal will serve as the screen medium. It will be a castellated cross-section, which will provide additional surface area compared to a flat screen and provide out-of-plane stiffness to the screen. The expanded metal openings will be diamond in shape with maximum clear dimensions of 1.7-inches by 0.6-inches, and will be fastened to a 316 stainless steel support frame. The size of the openings is in conformance with Federal 316b requirements. The sum of all clear openings in the screen less the areas blocked by support frame will provide enough cross-sectional flow area to limit the velocity across the screen to less than 1 foot per second.

The screen was designed in accordance with AISC Steel Design Guide 27 (2013), "Structural Stainless Steel" and design loads consistent with the application. The calculated differential head across a partially clogged screen is equal to pressure of 51 psf. The screens were designed for a working pressure of 100 psf. In addition to out of plane loads, screens will also be designed for vertical crushing loads due to the maximum stack of screens and stresses on the screen due to lifting.

Stop logs are provided to prevent water and/or soil intrusion into the intake tower. Each log is fitted with lifting lugs on top and lug pockets on the bottom. These components will facilitate log removal. The top of the stop logs when in place is 542.0 feet-msl. This provides 2 feet of freeboard above the 100 year flood event (540.0 feet-msl). The stop logs are subdivided into two groups: permanent stop logs and temporary stop logs.

Permanent stop logs are 2'-6" high stop logs and fabricated from 316 stainless steel. These will remain permanently at the bottom of each chamber entrance. A total of twenty-four permanent logs will be provided, two sets of six in the bottom of each stop log slot. These logs are intended to provide silt protection for Gates 4-W and 4-E – prevent lowest gates from being silted in.

Temporary stop logs are 7'-6" high and fabricated from carbon steel and will be painted with a high performance coating for erosion protection. Temporary logs will be stored on the intake tower in storage slots. The temporary logs will only be used when maintenance work is required in an intake tower chamber. Based on client requirements, whenever workers are going to be present in a intake tower chamber, two columns of temporary stop logs will be inserted into each stop log slots for the applicable intake tower chamber.

The stop logs will be designed in accordance with AISC 360-10 and AISC Steel Design Guide 27 as applicable and design loads consistent with the application. Every stop log, permanent or temporary, will be interchangeable and as such will be designed for the maximum amount of head (75 feet). Seals will be provide on the downstream faces of all logs and at the bottom to allow the logs to seal against the embedded stop log guide and bottom seal plates.

7.4 INTAKE ACCESS BRIDGE

Access to the proposed intake tower will require a bridge that originates from the access roadway on top of the dam. The top of the intake tower will be at the same elevation as the top of the dam, elev. 553 feet-msl. Initially, a clear width of 24 feet (overall width of 26 feet) was used as the design criteria to fit all necessary construction access equipment. After further evaluation, it was determined that a clear width of 30 feet (overall width of 32 feet) is necessary to accommodate future maintenance equipment, such as a large mobile crane, as well as to provide working space around the equipment. Locally widening the bridge near the intake structure in order to save bridge square footage was considered. However, the cost of additional framing in order to locally enlarge the width of the bridge would not result in a potential cost savings. Therefore, the bridge will have an overall width of 32 feet for its entire length.

The bridge was designed in accordance with the current American Association of State Highway and Transportation Officials, "AASHTO LRFD Bridge Design Specifications," 7th edition (2014) and Texas Department of Transportation bridge design standards and specifications. The bridge will consist of two 101 feet spans. One bridge abutment will be founded on shallow drilled shafts at the dam crest and the other abutment will consist of the intake tower's north wall. A

hammerhead bent cap on a single column will serve as the one interior bent. The bridge deck consists of cast-in-place concrete slab supported on Tx54 prestressed concrete beams, and guarded on each side by cast-in-place guard rails. Horizontal slots in the guardrail will serve as drainage slots – allowing surface water on the bridge to drain back into the lake.

7.5 PUMP STATION INTAKE CONDUIT AND LAYOUT

The pump station intake conduit will exit the intake tower base on the east face and continue east under the dam embankment. The conduit will consist of dual 78-inch lined steel pipes encased in reinforced concrete as a single structure. It will exit the tower in the center, with one pipe into each inner chamber. The concrete conduit structure will have properly compacted high plasticity clay backfilled against it in the upstream half of the dam, which is considered the core of the embankment. In the downstream shell of the embankment, the conduit will have a finger drain on either side with occasional sand filter diaphragms connecting them. The finger drains will connect to a drainage sump in the pump station for release.

In route to the pump station the intake conduit will be intersected by a diversion structure temporarily. The diversion structure will allow water discharge from the intake tower to be diverted around the pump station site until the pump station is in service. Once the pump station is in service the diversion structure will be by passed and filled in with compacted fill.

Immediately prior to reaching the pump station's south face, the dual conduit will be split into two individual reinforced concrete encase pipe conduits. This is to facilitate anticipated pump station design requirements.

Steel pipes will be mortar lined and will serve two functions. During construction of the conduit the pipes will function interior forms. After construction, and for the life of the structure, the pipes will serve as a water tight seal system. The reinforced concrete portion of the conduit was designed in accordance with ACI 350 for soil effective weights and pressures, water pressures, and bridge bent loads as required. It was designed ignoring any contributions in strength or hydraulic integrity provided by the lined steel pipes.

8.0 EMERGENCY SPILLWAY

The emergency spillway will be located in the right abutment, beyond the service spillway and will be an earthen, grass-lined broad crested weir and channel. The design configuration for the emergency spillway was developed to maintain the crest above the 100-year peak water surface elevation, thus, the emergency spillway would not be engaged for the 100-year storm and more frequent storms events.

The final emergency spillway configuration was developed using HEC-GeoRAS, an ArcGIS extension to create cross sections through the spillway, upstream and downstream of the spillway crest and to develop a HEC-RAS model. This model provides representation of the emergency spillway as the discharge is based on the physical geometry of each spillway section and a backwater analysis is used to compute the discharge through each cross section. HEC-RAS uses the Manning's Equation, shown below, to compute the discharge in each cross section.

$$Q = \frac{K_n}{n} \cdot A \cdot R^{\frac{2}{3}} \cdot S^{\frac{1}{2}}$$

Where:

Q = Discharge (cfs)

K_n = Conversion factor (1.49 for English Units)

n = Manning's Roughness Coefficient

A = Area (ft²)

R = Hydraulic Radius (ft)

S = Slope (ft/ft)

The proposed labyrinth spillway produced a slightly lower 100-year peak elevation so the crest of the emergency spillway was lowered to elevation 540 feet-msl. Since the labyrinth spillway is less efficient at higher water surface elevations, it was necessary to widen the emergency spillway to increase the discharge which would occur through the spillway during lower frequency events. The spillway was widened to 1,500 feet, with a crest width of 30 feet. The

upstream slope will be at a grade of 1 percent and the downstream slope at 0.5 percent. The side slopes will tie into the existing ground at 3.5:1V.

The hydraulic design of the emergency spillway, including its discharge rating curve, is described in the Preliminary Design Report (2014), which was used by the TCEQ to approve the spillway and emergency spillway configuration and the determination of the design flood. The configuration has not changed for the final design.

The final emergency spillway is shown in the Contract Drawings Section B.

9.0 INSTRUMENTATION

The embankment and service spillway for Lower Bois d'Arc Reservoir will have a variety of geotechnical mechanisms that will require monitoring both during and after construction. The following sections provide a discussion of recommended instrumentation for the embankment, internal drainage system, intake tower and bridge, service spillway, and intake tower. Refer to Section B of the Contract Drawings for the recommended locations for all elements.

9.1 EMBANKMENT

Instrumentation is recommended for the embankment to monitor pore pressure development and deformation during settlement. Potential instability of the slopes should also be monitored.

Pore pressures should be measured with a combination of vibrating wire piezometers and open standpipe piezometers. The vibrating wire piezometers should be used during construction and provides an automated, near instantaneous means of collecting data during construction. Open riser piezometers are recommended for installation near the end of construction to monitor pore pressures upon first filling, and for the long term. The standpipe piezometers will serve as a redundant system in select areas to spot check the data reported from the vibrating wire piezometers.

Deformations will be measured using surface monuments and settlement gauges. Temporary and permanent surface monuments will allow for the collection of survey data during and after construction at discrete points along the dam. The survey points will provide ground surface spatial and elevation data. Settlement gauges will provide vertical deformation data for the foundation material. Inclined meters will provide data related to lateral movement within the embankment and foundation. The selection of the monitoring points should include several lines of temporary monuments along the slopes in the valley sections to monitor for potential bulging of the embankment slope during the settlement process.

Slope instability in selected sections will be measured using inclinometers. These devices can also be used monitor for potential bulging of the embankment slope during the settlement process.

9.2 INTERNAL DRAINAGE SYSTEM

The internal drainage collection system is intended to control and collect seepage through the embankment section. The seepage will be directed to collection vaults along the toe of the dam. Each vault will include a weir and an electronic water level measurement indicator to monitor flow rates through each vault.

9.3 SERVICE SPILLWAY

Surface monuments are recommended at key areas of the service spillway and chute structures to monitor of movement in response to hydraulic loads and backfill settlement. Piezometers are also recommended along the spillway and chute walls to allow for monitoring pore pressures that may develop below the base slabs for both structures.

9.4 INTAKE STRUCTURE AND ACCESS BRIDGE

Instrumentation at the intake structure will include a level transmitter installed in each inner vertical chamber of the intake tower. A free space radar device, accessible from the intake tower platform level, will be used to determine the level of the water in the inner chamber. An LCD readout of the radar's signal will be available at the platform level, with a 2nd remote readout location inside the adjacent electrical room. Communications protocol will be HART or PROFIBUS, depending on NTMWD's preference. Expected range of water elevation level is 74 feet (water level 467 to 541 feet). The range of the radar device will be over 100 feet.

Surface monuments are recommended for each bridge span and at the tower and abutment to allow for monitoring of movement in response to settlement of the embankment.

9.5 ADDITIONAL MONITORING

It is also necessary to collect weather data, such as barometric pressure, temperature and rainfall, as these values can influence behavior of the infrastructure and instrumentation.

9.6 SUMMARY OF INSTRUMENTATION

The following list summarizes the type of instruments, use, collection criteria, and reporting criteria.

Instrument Type:	Surface Monuments
Monitoring Parameter:	Total vertical and horizontal movement
Monitoring schedule:	<ul style="list-style-type: none"> • Monthly during construction upon completion of construction and through first filling • Quarterly for first year after filling • Semi-annually for years two and three • Annually long-term
Reporting criteria:	<ul style="list-style-type: none"> • Localized frequency should increase to weekly during first filling if anomalous behavior is measured in surrounding instrumentation (settlement gauge, inclinometer, etc.). • Settlement vs time and settlement vs dam centerline station should be plotted, trends observed, and anomalous rates of settlement and/or differential settlement should be reported.
Instrument Type:	LiDAR Survey
Monitoring Parameter:	Spatial/surface deformations
Monitoring schedule:	<ul style="list-style-type: none"> • A LiDAR survey should be performed upon completion of construction, but prior to first filling. • LiDAR surveys should be performed every 10 years thereafter.
Reporting criteria:	N/A
Instrument Type:	Weir
Monitoring Parameter:	Seepage flow rate
Monitoring schedule:	<ul style="list-style-type: none"> • Monthly during construction • Weekly during first filling • Monthly for first year after filling • Monthly for years two and three • Quarterly on a long-term basis
Reporting criteria:	<ul style="list-style-type: none"> • Flow rate vs time and flow rate vs fill height should be plotted, trends observed, and anomalous behavior reported

Instrument Type:	Weather Station
Monitoring Parameter:	Temperature, precipitation, and barometric pressure
Monitoring schedule:	<ul style="list-style-type: none"> • Daily maximum and minimum temperature (automated) • Daily precipitation total (automated) • Barometric pressure (read at same time as piezometers, or automated for an hourly basis)
Reporting criteria:	N/A
Instrument Type:	Settlement gauge (electronic)
Monitoring Parameter:	Total vertical foundation displacement
Monitoring schedule:	<ul style="list-style-type: none"> • During construction <ul style="list-style-type: none"> ○ Weekly manual readings ○ Daily automatic readings • During first filling <ul style="list-style-type: none"> ○ Weekly manual readings ○ Daily automatic readings • First year after filling <ul style="list-style-type: none"> ○ Quarterly manual readings ○ Daily automatic readings • Years two and three <ul style="list-style-type: none"> ○ Semi-annually manual readings ○ Daily automatic readings • Long-term <ul style="list-style-type: none"> ○ Annually manual readings • Daily automatic readings
Reporting criteria:	<ul style="list-style-type: none"> • Settlement vs time, settlement vs fill height, and settlement vs dam centerline station should be plotted, trends observed, and anomalous behavior reported. • Measured values exceeding those provided in the above table below should be reported.
Instrument Type:	Inclinometer
Monitoring Parameter:	Total horizontal movement
Monitoring schedule:	<ul style="list-style-type: none"> • Weekly during construction • Weekly during first filling • Quarterly for first year after filling • Semi-annually for years two and three • Annually long-term
Reporting criteria:	<ul style="list-style-type: none"> • Typical horizontal displacements of 1 to 4 inches are expected. Movements exceeding this range should be reported. • Distinct, abrupt movement at elevation (kink) should be reported. • Displacements vs time and displacements vs fill height should be plotted, trends observed, and anomalous behavior reported

Instrument Type: Water level indicator																																																	
Monitoring Parameter: Reservoir and tailwater levels																																																	
Monitoring schedule:																																																	
<ul style="list-style-type: none"> • During first filling <ul style="list-style-type: none"> ○ Weekly manual readings ○ Daily automatic readings • First year after filling <ul style="list-style-type: none"> ○ Monthly manual readings ○ Daily automatic readings • Years two and three <ul style="list-style-type: none"> ○ Monthly manual readings ○ Daily automatic readings • Long-term <ul style="list-style-type: none"> ○ Quarterly manual readings • Daily automatic readings 																																																	
Reporting criteria: N/A																																																	
Instrument Type: Piezometer (electronic and open-riser)																																																	
Monitoring Parameter: Pore water pressure																																																	
Monitoring schedule:																																																	
<ul style="list-style-type: none"> • During construction: Weekly manual readings, and daily automatic readings • During first filling: Weekly manual readings, and daily automatic readings • First year after filling: Monthly manual readings and daily automatic readings • Years two and three: Monthly manual readings and daily automatic readings • Long-term: Quarterly manual readings and daily automatic readings <p>The following chart should be used to compare increases in pore pressure as a result of the applied load (compacted fill). Values in the table are based on an average pore pressure coefficient (change in pore pressure divided by change in overburden stress) equal to 0.36.</p>																																																	
<table border="1"> <thead> <tr> <th>Fill Height (ft)</th> <th>Pore Pressure Change (psf)</th> <th>Change in Pressure Head (ft)</th> </tr> </thead> <tbody> <tr><td>5</td><td>225</td><td>3.6</td></tr> <tr><td>10</td><td>450</td><td>7.2</td></tr> <tr><td>15</td><td>675</td><td>10.8</td></tr> <tr><td>20</td><td>900</td><td>14.4</td></tr> <tr><td>25</td><td>1125</td><td>18.0</td></tr> <tr><td>30</td><td>1350</td><td>21.6</td></tr> <tr><td>35</td><td>1575</td><td>25.2</td></tr> <tr><td>40</td><td>1800</td><td>28.8</td></tr> <tr><td>45</td><td>2025</td><td>32.5</td></tr> <tr><td>50</td><td>2250</td><td>36.1</td></tr> <tr><td>55</td><td>2475</td><td>39.7</td></tr> <tr><td>60</td><td>2700</td><td>43.3</td></tr> <tr><td>65</td><td>2925</td><td>46.9</td></tr> <tr><td>70</td><td>3150</td><td>50.5</td></tr> <tr><td>75</td><td>3375</td><td>54.1</td></tr> </tbody> </table>	Fill Height (ft)	Pore Pressure Change (psf)	Change in Pressure Head (ft)	5	225	3.6	10	450	7.2	15	675	10.8	20	900	14.4	25	1125	18.0	30	1350	21.6	35	1575	25.2	40	1800	28.8	45	2025	32.5	50	2250	36.1	55	2475	39.7	60	2700	43.3	65	2925	46.9	70	3150	50.5	75	3375	54.1	
Fill Height (ft)	Pore Pressure Change (psf)	Change in Pressure Head (ft)																																															
5	225	3.6																																															
10	450	7.2																																															
15	675	10.8																																															
20	900	14.4																																															
25	1125	18.0																																															
30	1350	21.6																																															
35	1575	25.2																																															
40	1800	28.8																																															
45	2025	32.5																																															
50	2250	36.1																																															
55	2475	39.7																																															
60	2700	43.3																																															
65	2925	46.9																																															
70	3150	50.5																																															
75	3375	54.1																																															
Reporting criteria:																																																	
<ul style="list-style-type: none"> • Changes in pore pressure exceeding those provide in table should be reported. • Pore pressure vs time and pore pressure vs fill height should be plotted, trends observed, and anomalous behavior reported. 																																																	

10.0 ELECTRICAL

10.1 POWER

Power will be distributed to the intake structure and service spillway by an overhead 6.9kV distribution system and pad-mounted, mineral oil-filled transformers. A temporary overhead 24.94kV electrical service fed from Fannin County Electric's new substation will be installed to provide power to the dam's distribution system. Permanent, underground 6.9kV electric service will come from the switchgear arrangement in the new pump station. A pad-mounted 6.9kV distribution switch will provide the switching function between temporary and permanent electric service(s). The distribution switch will have load interrupter switches in series with disconnect switches, elbow-connected and enclosed in a submersible, SF6-insulated, welded steel tank. Windows in the tank provide a clear view of the open gap, ground position, and ground bus.

The intake tower and spillway will both utilize 480Y/277V, 3-phase, 4-wire electrical service. Both locations require 480V to drive the 7.5 HP slide gate operators. Dry-type transformers installed at both locations will provide transformation to 208Y/120V electrical systems for receptacles and other equipment requiring 120V. Surge suppression devices will be integrated with the distribution system at all panelboard locations.

A manual transfer switch with rotary switch and camlock receptacles will be provided near the intake structure electrical room to facilitate connection to a portable generator for emergency power. All switches and electrical equipment installed outdoors will be furnished in NEMA 4X 316 stainless steel enclosures for durability and corrosion resistance.

The west dam and maintenance entrance will be served with 120/240V, 1-phase, 3-wire systems from overhead electrical lines. These services will be individually metered to serve a lighted controlled gate access point.

Power circuits traversing the intake bridge and spillway bridge will be concealed as much as practical. Smaller conduits will be embedded in the bridge side rail, while larger conduits will be

mounted to underside of the bridge deck with 316 stainless steel support members and hardware. Expansion/deflection fittings will be installed at all expansion joints and other necessary locations to accommodate movement.

10.2 LIGHTING

Lighting systems are required to provide adequate light levels for operations, maintenance, and security, as well as general observation to access structures and/or road conditions. Generally, all lighting sources will be LED type sourced from a U.S.-based established manufacturer. Light fixtures will come with a minimum 5-year warranty including the LED driver.

The intake structure bridge will feature recessed, LED “step light” fixtures with IP 68 rating, die-cast aluminum construction, stainless steel hardware and UL listing for wet location. Light fixtures at the intake tower platform will be both recessed (side rail) and surface-mounted (vertical columns for bridge crane). Exterior fixture will be controlled with a photocell and lighting contactor. The electrical room and storage room lighting will be 1’x4’ vaportight LED fixtures controlled by a single toggle switch near the door.

The service spillway bridge will be illuminated in a similar fashion. Access control gates near the spillway, and at all other controlled entry points, will be lit with pole-mounted LED type fixtures.

10.3 SECURITY/SCADA

Entrances to the dam and spillway will be controlled with fencing and motorized, car-activated access gates. Card readers, security cameras, and associated security system components and cabling will be installed after the completion of the dam and intake structure to interconnect with the pump station. Conduit and backboxes will be installed under this contract to enable future security and SCADA systems wiring, including fiber optic cabling.

11.0 LAKE BONHAM MODIFICATIONS

Lake Bonham Dam is located on Timber Creek in Fannin County, Texas, about five miles north of the City of Bonham. The dam, shown in Figure 11-1, is owned and operated by the City of Bonham. Downstream of Lake Bonham, Timber Creek is a tributary of Lower Bois d'Arc Creek, which will be impounded by the proposed Lower Bois d'Arc Dam. The presence of Lower Bois d'Arc Creek Reservoir immediately downstream of Lake Bonham Dam may cause adverse impacts to the spillway capacity and downstream slope erosion at Lake Bonham Dam. This chapter documents those potential impacts and provides recommendations for modifications at Lake Bonham Dam to mitigate the effects of such impacts. Proposed improvements include modifications to the existing emergency spillway and additional slope protection on the downstream face of the dam.

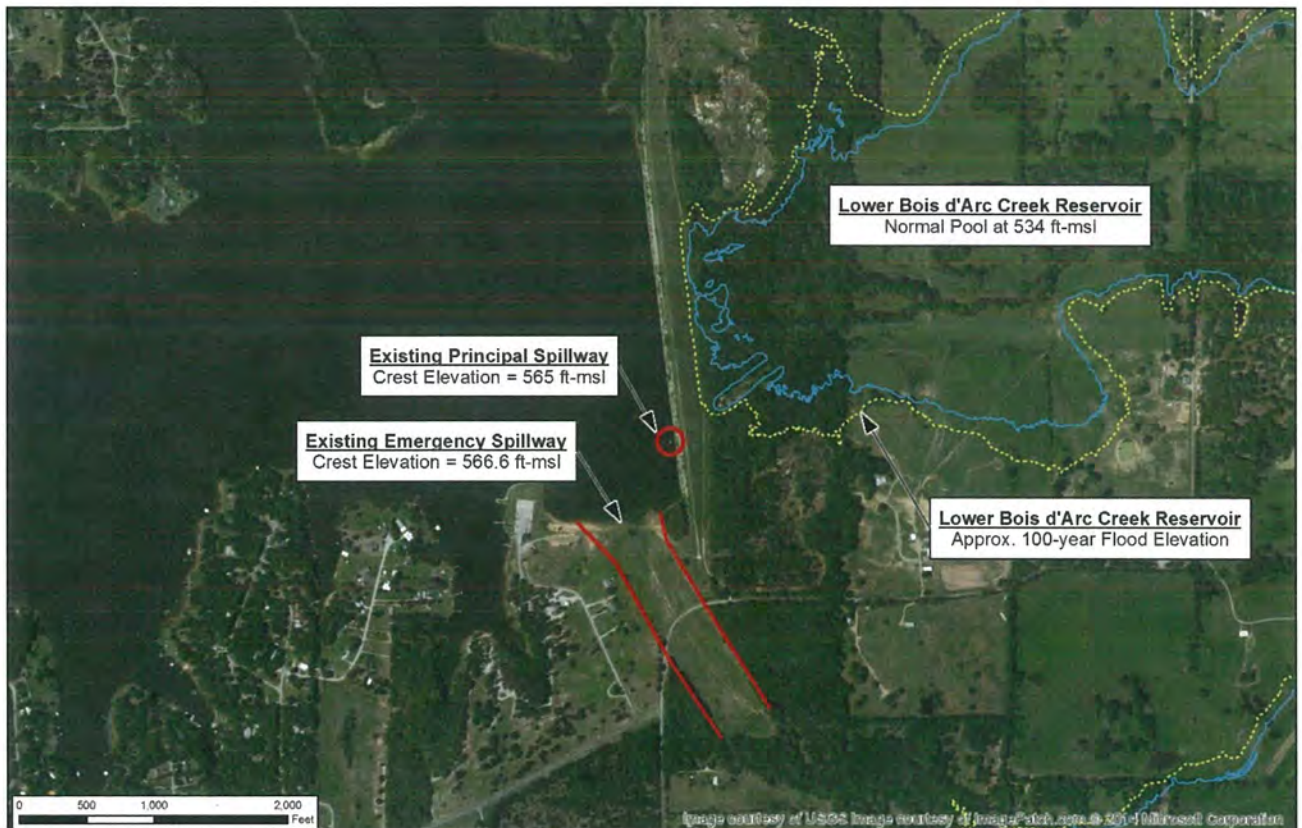

Figure 11-1: Location Map of Lake Bonham Dam

11.1 EMBANKMENT

11.1.1 Existing Conditions

Lake Bonham Dam consists of an earthen embankment with 3:1 upstream and downstream side slopes. The dam also contains a sand blanket drainage layer that daylights at the downstream toe. According to construction drawings, the top of the sand blanket layer is at approximately 536.5 feet-msl. In its current condition, the sand layer is overgrown by vegetation and indistinguishable from the rest of the toe area. In addition to the blanket drain, a toe drain system with 6-inch perforated pipes runs along a 1,400-foot long portion of the downstream toe. According to construction drawings of the dam, the toe drain varies in elevation from about 527 feet-msl to about 537 feet-msl and has two lateral outlets; however, these outlets have not been located in recent inspection reports. An unpaved access road runs along the downstream toe of the dam, providing access to the service spillway outlet and the left end of the dam.

There are no known embankment stability issues, though a possible seepage area was noted in the September 2012 inspection report performed by Hayter Engineering, Inc. This area appears to be located near Station 9+75, which has a toe elevation of approximately 550 feet-msl. During the June 4, 2014 inspection by FNI personnel, the survey flagging marking this potential seepage area was located, but no visible signs of seepage were noted.

11.1.2 Impact of Lower Bois d'Arc Creek Reservoir

The proposed normal pool elevation of Lower Bois d'Arc Creek Reservoir is 534 feet-msl, and the reservoir elevation is expected to fluctuate during flood events. Based on recent LiDAR topography data, the minimum downstream toe of Lake Bonham Dam is approximately 524 feet-msl, which would be submerged by Lower Bois d'Arc Creek Reservoir by as much as 10 feet under normal conditions. The total length of the downstream toe at or below 534 feet-msl is approximately 900 feet.

Two potential impacts to embankment stability are presented by the inundated portions of the downstream toe. The embankment could experience erosion damage caused by conditions associated with wave action and fluctuation in the downstream reservoir elevation, and there

could be stability concerns associated with impacts to the internal drainage system, limiting this system's ability to safely convey seepage flows through the embankment.

11.1.3 Proposed Modifications

Proposed modifications to address these concerns include the addition of a toe berm on the downstream slope of Lake Bonham Dam. The berm will be protected with soil cement or rock riprap on the downstream face to prevent erosion damage from wind and wave action or reservoir fluctuation. This is shown in Sheets F-4 and F-5 in Appendix B.

As mentioned previously, the sand blanket layer has a top elevation of 536.5 feet-msl, and the toe drain system has a minimum elevation of approximately 527 feet-msl. Portions of the toe drain system, including the lateral outlet lines, will be inundated by Lower Bois d'Arc Creek Reservoir, and the sand blanket layer will be covered by the proposed berm. Modifications to the drainage system will be made to provide a blanket drain and toe drain collector system below the proposed berm, which will be integrated into the existing system. These drains will also have lateral outlets through the soil cement slope protection that will be located above elevation 534 feet-msl to allow for adequate drainage.

The elevation of the berm was selected at the approximate 100-year flood elevation for Lower Bois d'Arc Creek Reservoir. The slope protection on the berm will guard against erosion on Lake Bonham Dam up to this elevation. The raised access road on top of the berm will also provide access across the downstream toe of Lake Bonham Dam during high water conditions in Lower Bois d'Arc Creek Reservoir.

During Final Design of these modifications, geotechnical stability analyses will be performed to confirm that Lake Bonham Dam will meet applicable standards for seepage and slope stability under proposed conditions.

11.2 SERVICE SPILLWAY

11.2.1 Existing Conditions

The service spillway has a crest elevation at 565 feet-msl with four 20-foot long sides that transition from the morning glory inlet to a 7-foot by 7-foot concrete conduit, which discharges into a stilling basin downstream of the dam. The downstream invert elevation of the conduit is 524 feet-msl. Discharges through the conduit enter a stilling basin with flared wing walls then transition through an earth cut pilot channel to the natural channel of Timber Creek downstream of the dam. This is shown in Sheet F-6 in Appendix B.

11.2.2 Impact of Lower Bois d’Arc Creek Reservoir

The normal pool elevation of the proposed Lower Bois d’Arc Creek Reservoir is 534 feet-msl, and the 100-year flood is expected to produce a six to seven-foot rise in the reservoir elevation. With the service spillway stilling basin at elevation 524 feet-msl, the primary impact of Lower Bois d’Arc Creek Reservoir on Lake Bonham Dam is reduced discharge capacity through the service spillway. The higher tailwater elevations from Lower Bois d’Arc Creek Reservoir, under both normal and flood conditions, will submerge the downstream outlet of the service spillway and reduce its discharge efficiency. In general, the reduction in spillway capacity caused by the presence of Lower Bois d’Arc Creek Reservoir is, on average, about 17%.

The assumed tailwater in Lower Bois d’Arc Creek Reservoir was established based on corresponding frequency events between the two reservoirs. A drainage area ratio was used to determine the frequency flood event applied to the Lower Bois d’Arc watershed based on the frequency event assumed to be occurring in the Lake Bonham watershed. For example, during the 100-year storm event on Lake Bonham, Lower Bois d’Arc Creek Reservoir is assumed to be at a 50-year flood elevation. Determining these various elevations involved an iterative process to produce a reasonable discharge rating curve, as described.

11.2.3 Proposed Modifications

Proposed modifications to the emergency spillway, as described in the following section, are designed to mitigate the impacts of the reduced discharge capacity of the service spillway. In order to determine the necessary modifications, various hypothetical flood frequency events were computed for Lake Bonham. The intention of the design was to maintain or reduce the flood elevation for a wide range of possible storm events. A hydrologic model for the proposed Lower Bois d'Arc Creek Reservoir was developed in HEC-HMS during the Water Rights Application process. This model included a single drainage basin representing the contributing drainage area to Lake Bonham. This model was updated with revised discharge rating curves for the emergency and service spillways, and a range of storm events was computed from a 1-year frequency event to the PMF. Each of the frequency flood events from 1-year to 500-year had a duration of 24 hours, and the critical duration for the PMF event was also 24 hours. The hydrologic model was run under both existing and proposed conditions, and the resulting reservoir elevations in Lake Bonham are presented in Table 11-1: below.

Table 11-1: Hydrologic Model Results

Storm Event	Existing Conditions (ft-msl)	Proposed Modifications (ft-msl)	Change in Elevation (feet)
1-yr	566.79	566.79	0.00
2-yr	567.68	567.66	-0.02
5-yr	568.61	568.60	-0.01
10-yr	569.36	569.36	0.00
25-yr	570.19	570.15	-0.04
50-yr	570.85	570.79	-0.06
100-yr	571.48	571.40	-0.08
500-yr	573.07	572.96	-0.11
PMF (24-hr)	579.69	579.47	-0.22

Compared with the existing conditions model results, it is apparent that the proposed modifications produce either no change or a slight improvement in the flood elevations for the full range of modeled storm events. These results indicate that the proposed modifications

should mitigate the flooding impacts of Lower Bois d’Arc Creek Reservoir downstream of Lake Bonham Dam.

In addition to the modifications in the emergency spillway, a solid concrete wall will be installed at the downstream end of the service spillway stilling basin to allow for inspections of the stilling basin and conduit when the outlet is submerged from Lower Bois d’Arc Creek Reservoir. A small sluice gate will be installed in this wall to allow the stilling basin to be dewatered for inspection.

11.3 EMERGENCY SPILLWAY

11.3.1 Existing Conditions

The control section of the emergency spillway is at approximately elevation 570 feet-msl. However, after the initial construction of the dam in 1989, complaints of flooding around the lake led the City to cut a pilot channel through the emergency spillway to provide greater discharge capacity at lower lake elevations. This pilot channel has a crest elevation of approximately 566.6 feet-msl and an average bottom width of 10 feet. The earthen side slopes are at an angle of approximately 8:1. Additionally, County Road 2610 crosses through the middle of the emergency spillway roughly at the same grade as the rest of the spillway area. Three 36-inch corrugated metal pipe (CMP) culverts are placed in the pilot channel under the roadway to pass smaller flows.

11.3.2 Impact of Lower Bois d’Arc Creek Reservoir

The control section of the emergency spillway is located over 30 feet above the normal pool elevation of Lower Bois d’Arc Creek Reservoir. At this elevation, the presence of the Reservoir will not produce any impacts associated with discharge capacity reduction or erosion concerns at the Lake Bonham Dam emergency spillway.

11.3.3 Proposed Modifications

While the emergency spillway will not be directly impacted by Lower Bois d’Arc Creek Reservoir, the service spillway will experience a reduction in discharge capacity, as discussed in the previous section. In order to mitigate the impacts of the reduced discharge capacity of the service spillway,

FNI proposed modifications to increase the discharge capacity of the emergency spillway pilot channel. The proposed modifications would widen the average bottom width of the pilot channel from 10 feet to 40 feet with 5:1 side slopes. The pilot channel is also proposed to be lined with soil cement to provide erosion protection for the increased flows. The crest of the control section of the pilot channel would remain at approximately 566.6 feet-msl. Also, the three CMP culverts below County Road 2610 would be replaced with five 3-foot by 6-foot concrete box culverts. No other modifications to the emergency spillway are proposed. This is shown in Figure 11-2: and in Sheets F-2 and F-3 in Appendix B.

An emergency spillway discharge rating curve was calculated using a HEC-RAS hydraulic model of the spillway with cross-sections based on available LiDAR topography. The same model was updated with the proposed modifications to provide a comparison of the discharge capacity of the emergency spillway between proposed and existing conditions. In a relative sense, the discharge capacity of the emergency spillway increased significantly (3 to 4 times that of existing conditions) for the lower elevation ranges where flow was contained within the pilot channel. Once the full width of the emergency spillway is engaged, the proposed modifications produce discharge capacities about 10-15% higher than existing conditions. Further details of the hydraulic and hydrologic calculations to support the Preliminary Design of these modifications is provided with the discussion of the service spillway impacts in the previous section.

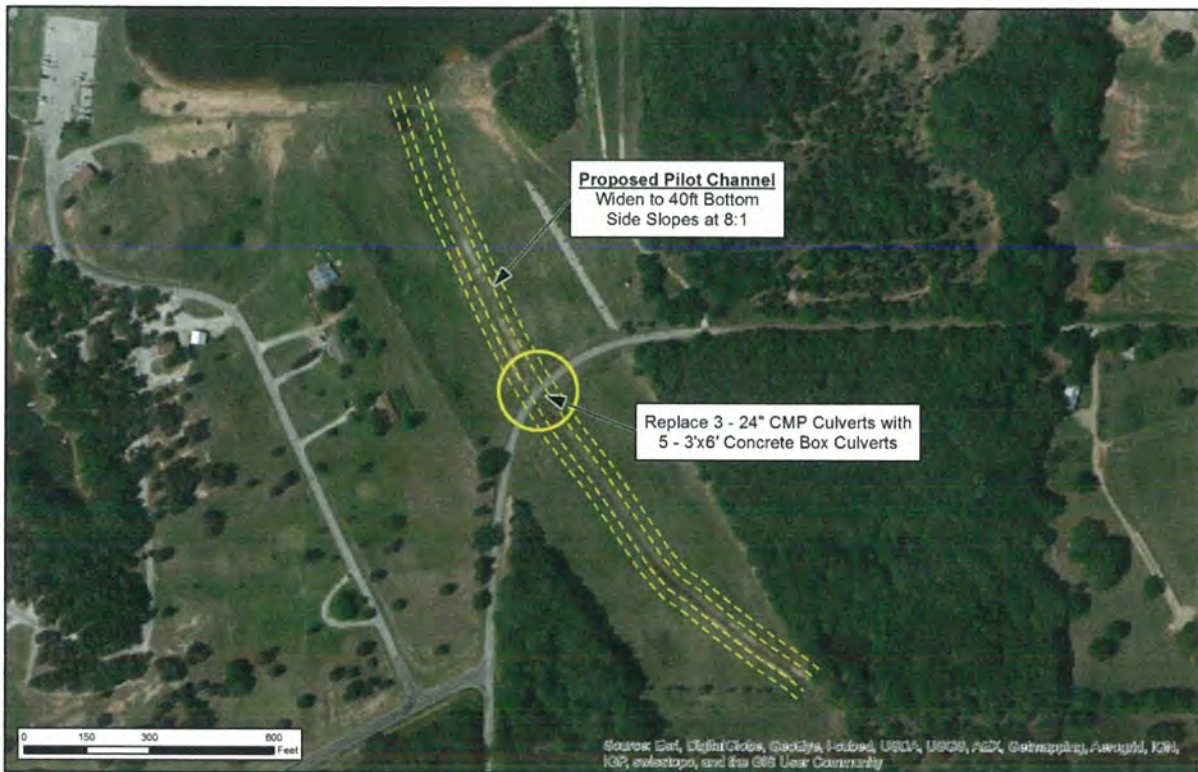

Figure 11-2: Emergency Spillway Modifications

11.4 OUTLET WORKS

11.4.1 Existing Conditions

The outlet works for Lake Bonham Dam consist of a single 18-inch concrete pipe that discharges into the service spillway conduit. The intake for this pipe is located about 200 feet north of the service spillway drop inlet structure at an elevation of 538 feet-msl. Flow through the outlet works is controlled by two flanged gate valves located in a concrete vault adjacent to the service spillway conduit. The valve stems are located just off the crest of the dam near the service spillway. The outlet works pipe has a downstream invert elevation of 536.37 feet-msl. According to Bonham Public Works personnel, the valves for the outlet works have not been operated in at least 20 years. The condition and functionality of these valves is therefore unknown. Water supply diversions are made from a reservoir intake pump station located away from the dam itself.

11.4.2 Impact of Lower Bois d'Arc Creek Reservoir

Under normal conditions, Lower Bois d'Arc Creek Reservoir will have no impact on the discharge capacity of the Lake Bonham Dam outlet works because the pipe invert of the outlet works is 2.37 feet above the proposed normal pool of Lower Bois d'Arc Creek Reservoir. Additionally, it is likely that any low flow releases necessary to satisfy downstream senior water rights would be made through Lower Bois d'Arc Creek Reservoir, rather than Lake Bonham Dam.

11.4.3 Proposed Modifications

No modifications are currently proposed for the Lake Bonham Dam outlet works.

11.5 DAM SAFETY INSPECTIONS

In its current condition, regular dam safety inspections are required for Lake Bonham Dam and have been ongoing since its original construction. The most recent inspection was performed by Hayter Engineering, Inc. and documented in a report dated September 2012. Regular dam safety inspections should continue for Lake Bonham Dam. Minor adjustments to the procedures for these inspections would include dewatering of the stilling basin to observe the interior walls of the stilling basin and service spillway conduit, along with observations of the new internal drainage system outlets to confirm suitable operation. The dam safety hazard classification may be lowered from high to significant, as mentioned by Hayter Engineering in the 2012 inspection report. However, additional analyses would be necessary to confirm this change in hazard classification. Regardless of the changed hazard classification, state dam safety requirements would mostly remain the same as the current condition.

Flood routing through Lake Bonham Dam during high flow events will operate much the same as the current condition, only with reduced service spillway discharges which will be compensated for by increased emergency spillway discharges. The routing of large flood events through Lake Bonham Dam was taken into consideration in modeling similar flood events for Lower Bois d'Arc Creek Reservoir. Therefore, there is no significant impact to operations during high flow events.

APPENDIX A

REFERENCES

REFERENCES

- Bureau of Economic Geology, "Geologic Atlas of Texas, Sherman Sheet." The University of Texas at Austin, Texas. 1967 (Rev. 1991).
- Bureau of Economic Geology, "Geologic Atlas of Texas, Texarkana Sheet." The University of Texas at Austin, Texas. 1966 (Rev. 1979).
- Bureau of Reclamation. (1987) Design of Small Dams, Third Edition. Washington D. C.: Government Printing Office.
- Duncan, J.M., O'Neil, B., Brandon, T. and VandenBerge, D.R., "Evaluation of Potential for Erosion in Levees and Levee Foundations, CGPR Report #64," Virginia Tech Center for Geotechnical Practice and Research. (2011).
- Duncan, J.M., Wright, S.G. and Wong, K.A., "Slope Stability during Rapid Drawdown", Proceedings of H. Bolton Seed Memorial Symposium. Vol. 2. 1990.
- Fell, R., Stapledon, D., Bell, G., MacGregor, P. "Geotechnical Engineering of Dams," CRC Press. 2005.
- Foster, M, and Fell, R., "Assessing Embankment Dam Filters Which Do Not Satisfy Design Criteria", UNICIV Rep. No. R-376, School of Civil and Environmental Engineering., University of New South Wales, Sydney, Australia, 1999.
- Freese and Nichols, Inc. (September 5, 2014) North Texas Municipal Water District Reservoir Accounting Plan for the Lower Bois d'Arc Creek Reservoir.
- Freese and Nichols, Inc. 1984. *Report on New Bonham Reservoir*, prepared for the North Texas Municipal Water District and the Red River Authority of Texas.
- Freese and Nichols, Inc. 1996. *Preliminary Study of Additional Sources of Water Supply*, prepared for the North Texas Municipal Water District.
- Freese and Nichols, Inc. et al. 2001. *Region C Water Plan*, prepared for the Region C Water Planning Group.
- Freese and Nichols, Inc. et al. 2006. *2006 Region C Water Plan*, prepared for the Region C Water Planning Group.
- Freese and Nichols, Report Supporting an Application for a Texas Water Right for Lower Bois d'Arc Creek Reservoir, December 2006, prepared for the North Texas Municipal Water District
- Freese and Nichols, *Lower Bois d'Arc Creek Reservoir Preliminary Design Report* for North Texas Municipal Water District, October 2014

- International Code Council, International Building Code, 2012 Edition, Country Club Hills, Illinois, Section 1613.
- Jones, G. M., Bosserman, B. E., Sanks, R. L., & Tchobanoglous, G. (Eds.). (2006). Pumping station design. Gulf Professional Publishing.
- Perham, Roscoe E. (1988) Elements of Floating-Debris Control Systems. Washington D.C.: US Army Corps of Engineers.
- Red River Compact Commission (Arkansas, Louisiana, Oklahoma, and Texas). 1979. Red River Compact with Supplemental Interpretive Comments of Legal Advisory Committee.
- Sohl, N. F. and J. P. Owens. "Cretaceous stratigraphy of the Carolina Coastal Plain," University of Tennessee Press, Knoxville, TN. 1991.
- Texas Commission on Environmental Quality, "Design and Construction Guidelines for Dams in Texas - RG-473," Austin, Texas. August 2009.
- Texas Commission on Environmental Quality. (September 5, 2014) Draft Water Use Permit No. 12151.
- Texas Commission on Environmental Water Quality. 2006. Hydrologic and Hydraulic Guidelines for Dams in Texas, August 28, 2006.
- Texas Water Development Board. 2002. *Water for Texas – 2002*.
- Texas Water Development Board. 2006. *Water for Texas – 2007*.
- U.S. Army Corps of Engineers, "Engineering and Design, Seepage Analysis and Control for Dams, EM 1110-2-1901." Vicksburg, MS. Original (30 Sep 1986) and Change 1 (30 April 1993)
- U.S. Army Corps of Engineers, "Settlement Analysis Engineering Manual 1110-1-1904." Washington D.C. September 1990.
- U.S. Army Corps of Engineers, "Slope Stability Engineering Manual 1110-2-1902." Vicksburg, MS. October 2003.
- U.S. Army Corps of Engineers. Engineer Manual EM 1110-2-2100: Stability Analysis of Concrete Structures. Washington D.C.: USACE, December 1, 2005.
- U.S. Army Corps of Engineers. Engineer Manual EM 1110-2-2104: Strength Design for Reinforced-Concrete Hydraulic Structures. Washington D.C.: USACE, August 20, 2003.
- U.S. Army Corps of Engineers. Engineer Manual EM 1110-2-2200: Gravity Dam Design. Washington D.C.: USACE, June 30, 1995.

U.S. Army Corps of Engineers. Engineer Manual EM 1110-2-2502: Retaining and Flood Walls. Washington D.C.: USACE, September 29, 1989.

Wahl, Tony L. (1992) Investigation of Debris and Safety Boom Alternatives for Bureau of Reclamation Use. Denver Colorado: Bureau of Reclamation.

Walker, W.L. and Duncan, J.M. "Lateral Bulging of Earth Dams," ASCE Journal of Geotechnical Engineering Vol. 110, Page 923-937. 1984.

**APPENDIX B
GEOTECHNICAL FIGURES**

(Complete Geotechnical Data Report under Separate Cover)

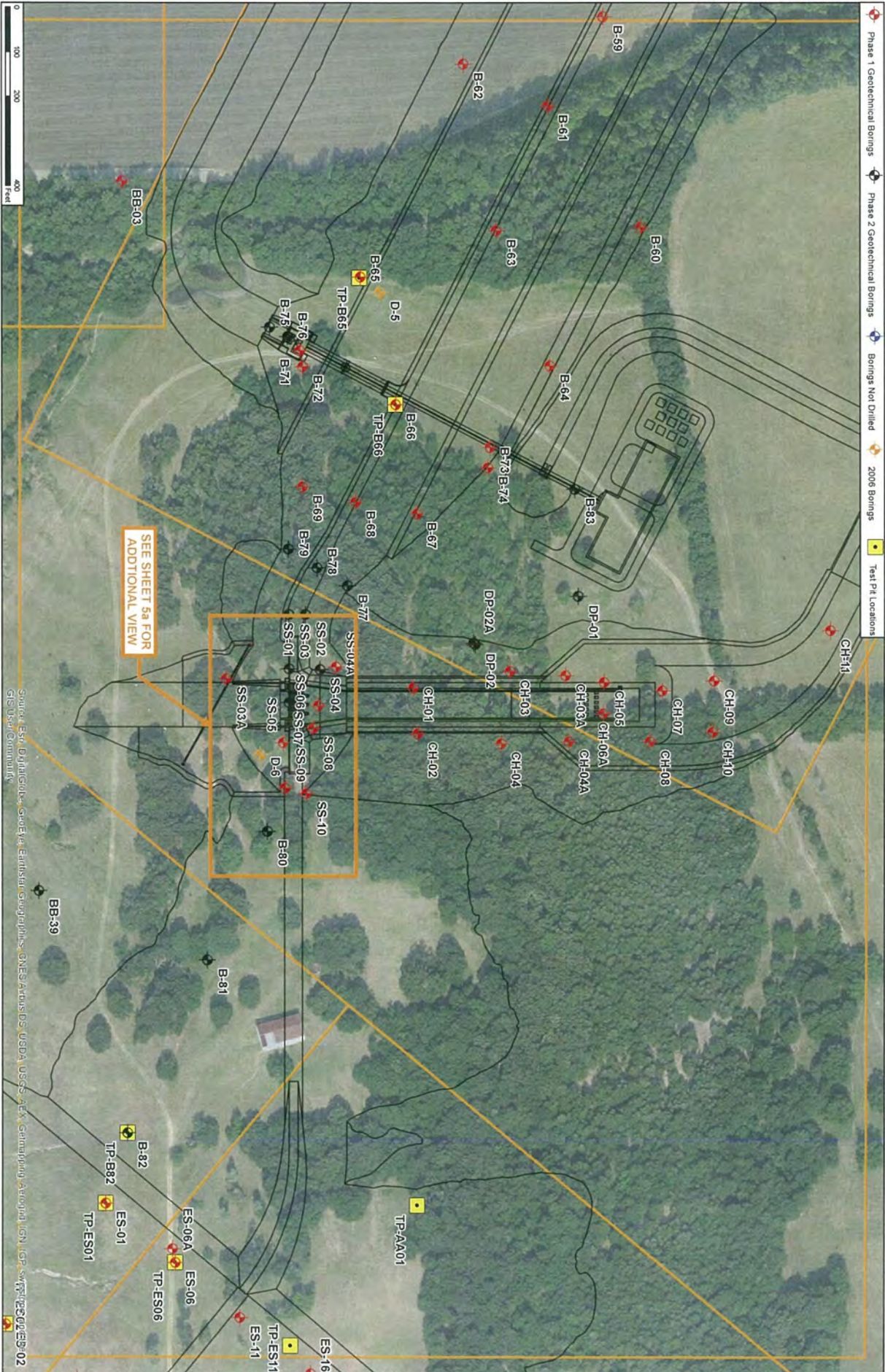

FILE: NTD13565
 DATUM & COORDINATE SYSTEM: BLM Mapbook Phase 2.mxd
 MAP: 1981 State Park Texas North Central F.P.S. 42031 Feet
 DATE: September, 2015
 PREPARED BY: NBR

FREES NICHOLS
 4055 International Plaza
 Suite 200
 Fort Worth, TX 76109

NORTH TEXAS MUNICIPAL WATER DISTRICT
LOWER BOIS D'ARC RESERVOIR
BORING LOCATION MAP - PHASE 2
 (B-66 B-82) (SS-01 SS-10) (CH-01 CH-10)



Sheet
5

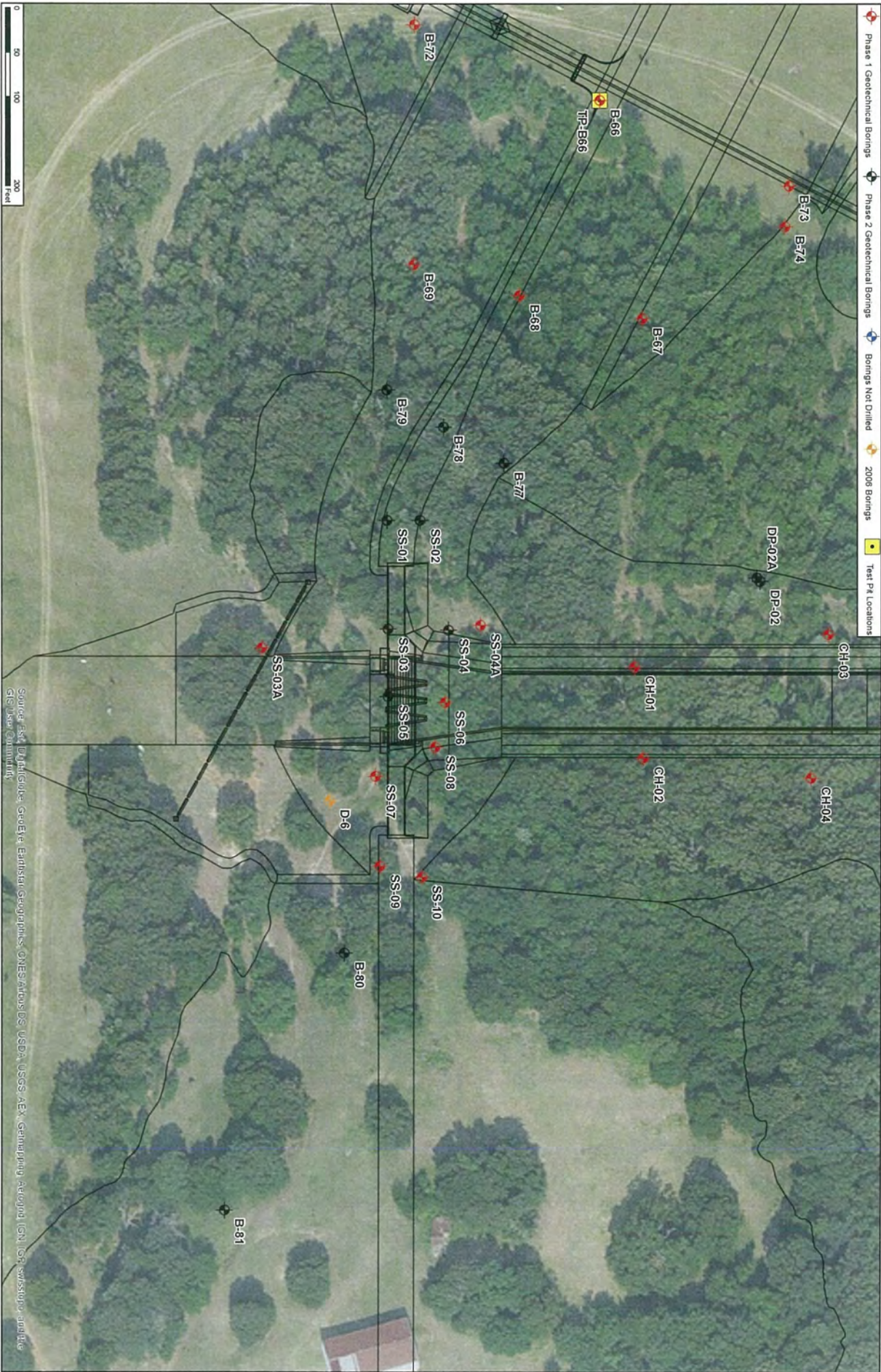

Source: Esri, DigitalGlobe, GeoEye, Earthstar Geographics, CNES/Airbus DS, USDA, USGS, AeroX, Gemmapro, AerialGIS, SwissTopo, and the
 GEBCO Community

PROJECT	NTD13085
FILE	Spillway SH Ph2.mxd
DATUM & COORDINATE SYSTEM	NAD 1983 StatePlane Texas North Central FIPS 4202 Feet
DATE	October, 2015
PREPARED BY	MRB

FRESE & NICHOLS
 4055 International Plaza
 Suite 200
 Fort Worth, TX 76109

NORTH TEXAS MUNICIPAL WATER DISTRICT
LOWER BOIS D'ARC RESERVOIR
BORING LOCATION MAP - PHASE 2



Sheet
5a

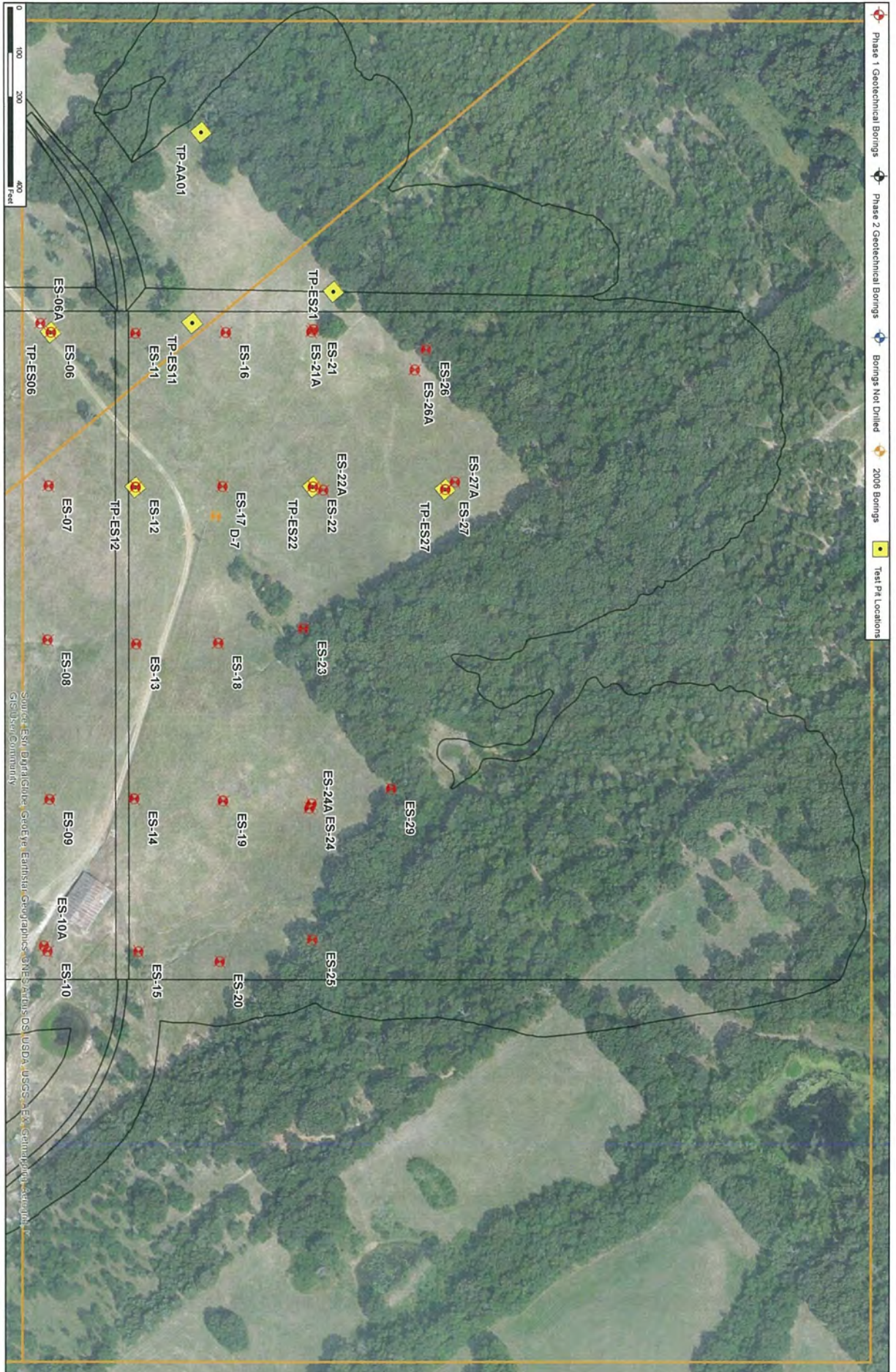

FILE PROJECT	NTD13065
FILE	BLM Mapbook Phase 2.mxd
DATUM & COORDINATE SYSTEM	4055 International Plaza Suite 200 Fort Worth, TX 76109
1-800-251-1111 StatePlane Texas North Central FIPS 43202 Feet	
DATE	September, 2015
PREPARED BY	NRB

FREESE NICHOLS
 4055 International Plaza
 Suite 200
 Fort Worth, TX 76109

NORTH TEXAS MUNICIPAL WATER DISTRICT
 LOWER BOIS D'ARC RESERVOIR
BORING LOCATION MAP - PHASE 2
 (ES-06 ES-29)



Sheet
6



Phase 1 Geotechnical Borings
 Phase 2 Geotechnical Borings
 Borings Not Drilled
 2006 Borings
 Test Pit Locations

Source Erosion Control - Gate
 GIS User: Community

FILE PROJECT	NTD13565
FILE	BLM Mapbook Phase 2.mxd
DATUM & COORDINATE SYSTEM	4055 International Plaza Suite 200 Fort Worth, TX 76109
MAP 1983 StatePlane Texas North Central FIPS 4202 Feet	
DATE	September, 2015
PREPARED BY	NBB



NORTH TEXAS MUNICIPAL WATER DISTRICT
 LOWER BOIS D'ARC RESERVOIR
 BORING LOCATION MAP - PHASE 2
 (BB-22- BB-29)



Sheet
 8



◆ Phase 1 Geotechnical Borings
◆ Phase 2 Geotechnical Borings
◆ Borings Not Drilled
◆ 2006 Borings
■ Test Pit Locations

Source: Esri, DigitalGlobe, GeoEye, Earthstar Geographics, CNES/Airbus DS, USDA, USGS, AeroX, Geomatics, Bing, IGN, Swire, Cofesa, and the GIS User Community

FNI PROJECT		NTD13565
FILE	BLM Mapbook Phase 2.mxd	
DATUM & COORDINATE SYSTEM		
NAD 1983 StatePlane Texas North Central FIPS 4202 Feet		
DATE	September, 2015	
PREPARED BY	NBR	

FREESE NICHOLS
 4055 International Plaza
 Suite 200
 Fort Worth, TX 76109

NORTH TEXAS MUNICIPAL WATER DISTRICT
LOWER BOIS D'ARC RESERVOIR
BORING LOCATION MAP - PHASE 2
 (BB-10-BB-12) (BB-16 BB-18)

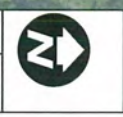

Sheet
10

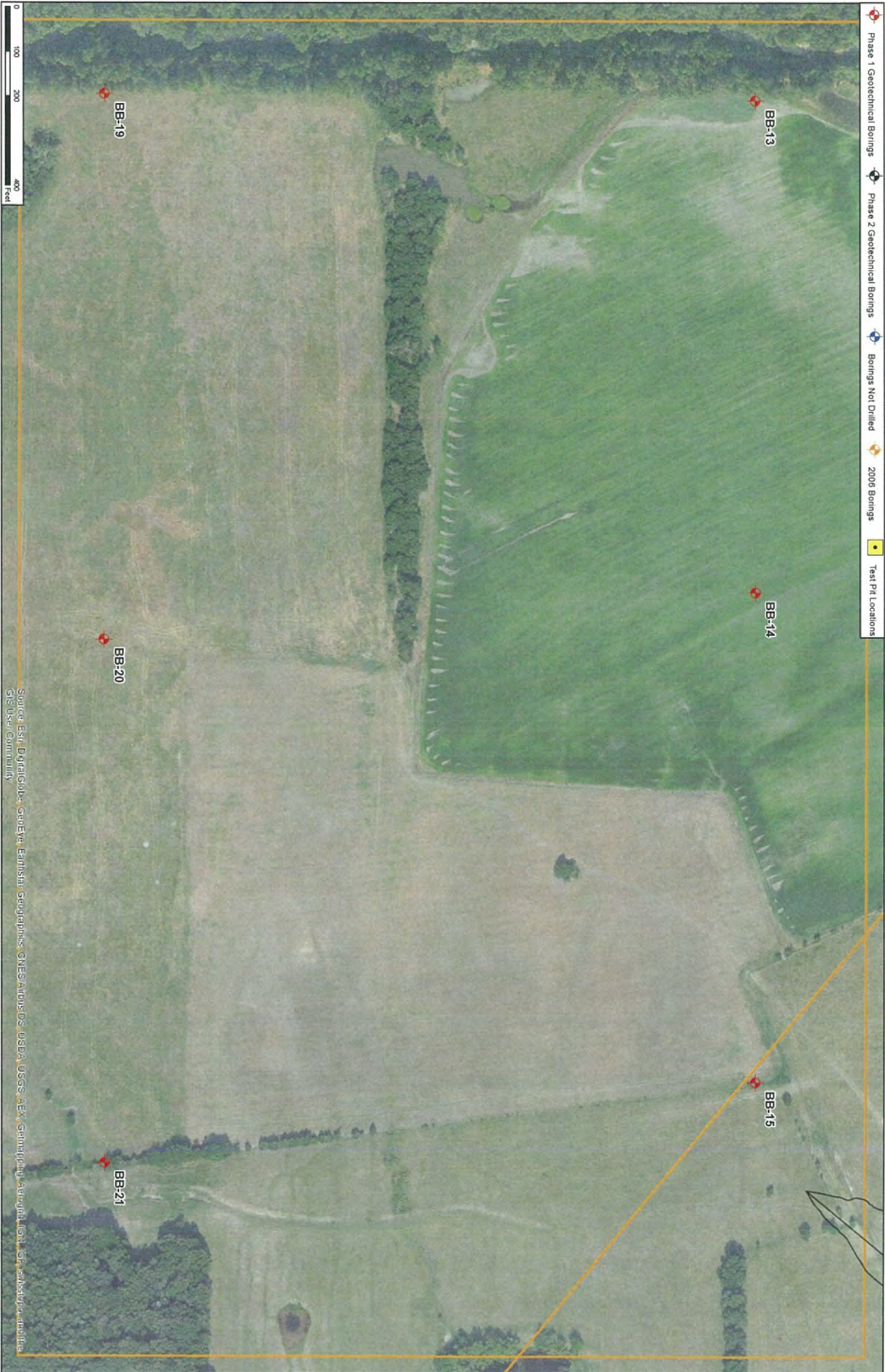

Phase 1 Geotechnical Borings
 Phase 2 Geotechnical Borings
 Borings Not Drilled
 2006 Borings
 Test Pit Locations

Source: Esri, DigitalGlobe, GeoEye, Earthstar Geographics, CNES/Airbus DS, USDA, USGS, AeroX, GeoEye, IGN, AerGRID, Airbus, etc.
 GIS User Community

FNI PROJECT	NTD13565
FILE	BLM Mapbook Phase 2.mxd
DATUM & COORDINATE SYSTEM	
NAD 1983 StatePlane Texas North Central FIPS 4202 Feet	
DATE	September, 2015
PREPARED BY	NRB

FRESE NICHOLS
 4055 International Plaza
 Suite 200
 Fort Worth, TX 76109

NORTH TEXAS MUNICIPAL WATER DISTRICT
 LOWER BOIS D'ARC RESERVOIR
BORING LOCATION MAP - PHASE 2
 (BB-13 - BB-15) (BB-19 BB-21)

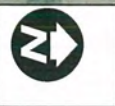

Sheet
 11

Material	Seepage Parameters				Slope Stability Condition and Parameters						
	Hydraulic Conductivity		Conductivity Ratio	Moist Unit Wt.	Drained		Consolidated-Undrained		Unconsolidated-Undrained		
	cm/sec	ft/sec			k_v/k_x	γ_w pcf	c' , psf	ϕ' , deg.	c , psf	ϕ , deg.	c , psf
1	9.0 E-08	3.0 E-09	0.25	125	250	18.0	500	13.0	2,000	0	0
2	2.0 E-06	6.6 E-08	1.0	125	50	18.0	100	13.0	--	--	--
3	5.0 E-09	1.6 E-10	0.25	125	250	18.0	500	12.0	1,000	0	0
4	7.0 E-08	2.3 E-09	0.33	128	100	26.0	200	20.0	2,000	0	0
5	7.0 E-06	2.3 E-07	0.25	130	0	28.0	--	--	--	--	--
6	1.0 E-02	3.4 E-04	0.25	130	0	30.0	--	--	--	--	--
7	3.0 E-09	1.0 E-10	0.1	140	8,000	26.0	--	--	--	--	--
8	3.0 E-09	1.0 E-10	0.1	135	3,000	18.0	--	--	--	--	--
9	1.0 E-07	3.3 E-09	1.0	150	500	35.0	--	--	--	--	--
10	1.5 E-02	5.0 E-04	0.33	125	0	32.0	--	--	--	--	--
11	1.0 E-08	3.3 E-10	1.0	150	500	35.0	--	--	--	--	--
12	4.9	1.6 E-01	1.0	130	0	32.0	--	--	--	--	--

General Notes:

- All elevations are in NAVD88 feet mean sea level (feet-msl).
- Internal embankment features/zones and foundation stratigraphy are approximate and presented for illustrative purposes only.
- Phreatic surfaces for the rapid drawdown slope stability analysis, were estimated from the correlating seepage analysis.
- The Rapid Drawdown condition was taken from:
 - The Normal Pool Elevation (534 ft-msl) to the ground surface
 - The 100-year Flood Elevation (540 ft-msl) to the Normal Pool Elevation (534 ft-msl)
 - The 500-year Flood Elevation (540 ft-msl) to the Normal Pool Elevation (534 ft-msl)
 - The PMF Elevation (550 ft-msl) to the Normal Pool Elevation (534 ft-msl)

Seepage Boundary Summary		
Boundary Condition Symbol	Type	Potential Seepage Face Review
	Hydraulic	Flux = 0 Yes
	Hydraulic	Flux = 0 No
	Hydraulic	Head = 534.0 No
	Hydraulic	Head = 540.0 No
	Hydraulic	Head = 542.0 No
	Hydraulic	Head = 550.0 No
	Hydraulic	Pressure = 0 No

Legend	
	Phreatic Surface
	Total Head Contour Labels
	Flux
	Slip Surface Entry and Exit
	Calculated Factor of Safety

FNI PROJECT: NTD13565
 FILE: T:\GEO\2.31 - Numerical Modeling
 DATE: Nov. 16, 2015
 PREPARED: HS/MTM



NORTH TEXAS MUNICIPAL WATER DISTRICT
LOWER BOIS D'ARC CREEK RESERVOIR
 SEEPAGE AND SLOPE STABILITY ANALYSIS
PARAMETER AND SYMBOL LEGEND—ALL SECTIONS

STATION 78+00 GEOMETRY

EMBANKMENT & FOUNDATION STRATIGRAPHY

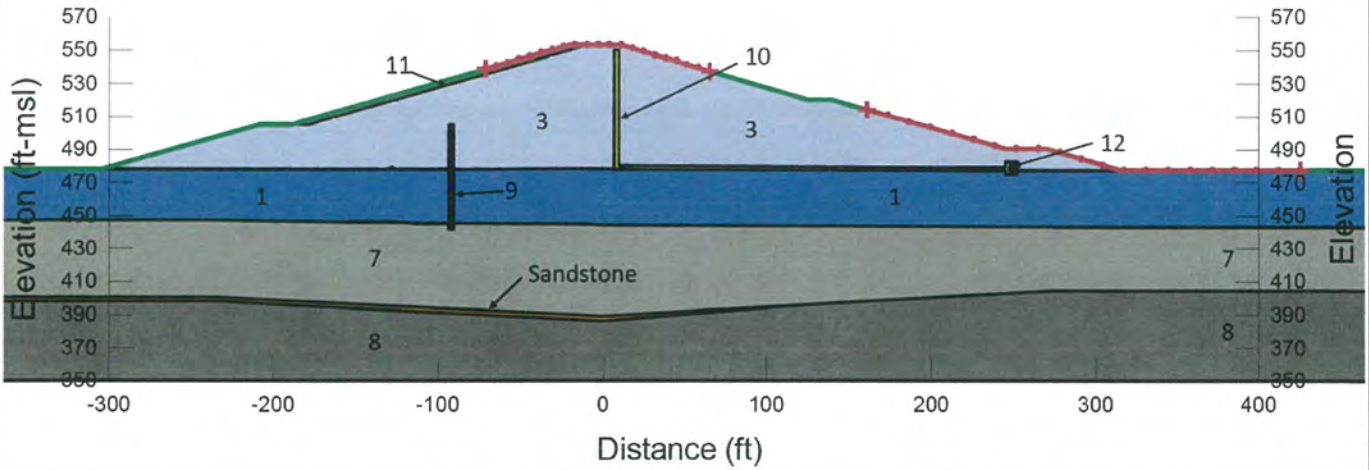

HYDRAULIC BOUNDARY CONDITIONS FOR EMBANKMENT

Water Surface Varies
(See Table on Legend)

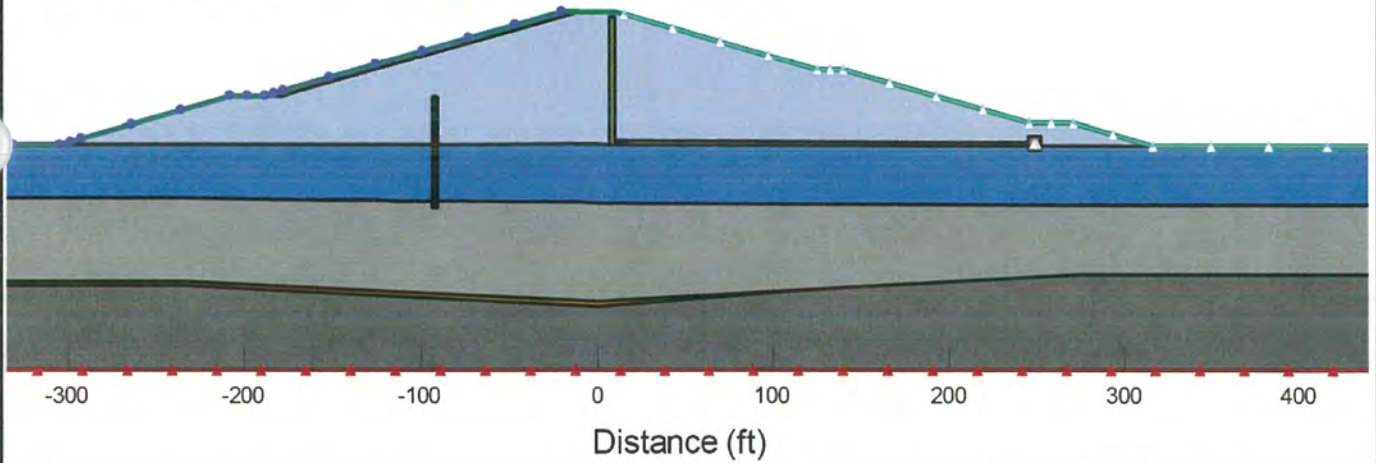

UPSTREAM HYDRAULIC BOUNDARY CONDITIONS

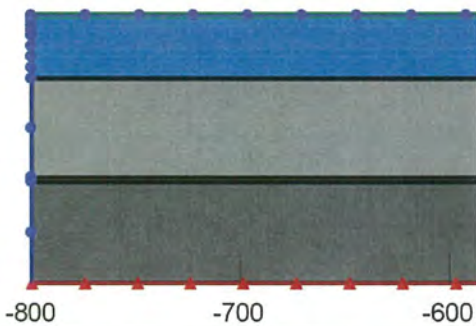

DOWNSTREAM HYDRAULIC BOUNDARY CONDITIONS

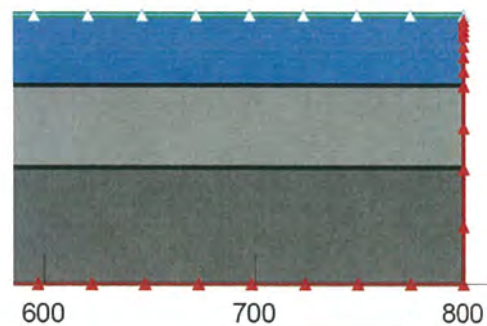

FNI PROJECT: NTD13565
FILE: T:\GEO\2.31 - Numerical Modeling\
DATE: Nov. 16, 2015
PREPARED: HS/MTM

**FREESE
AND
NICHOLS**
4055 INTERNATIONAL PLAZA, STE. 200
FORT WORTH, TX 76109

NORTH TEXAS MUNICIPAL WATER DISTRICT
LOWER BOIS D'ARC CREEK RESERVOIR
SEEPAGE AND SLOPE STABILITY ANALYSIS
SECTION AT STATION 78+00

PLATE
14

STATION 78+00 SEEPAGE ANALYSIS RESULTS

STEADY-STATE SEEPAGE —NORMAL POOL ELEVATION (534 FT-MSL)

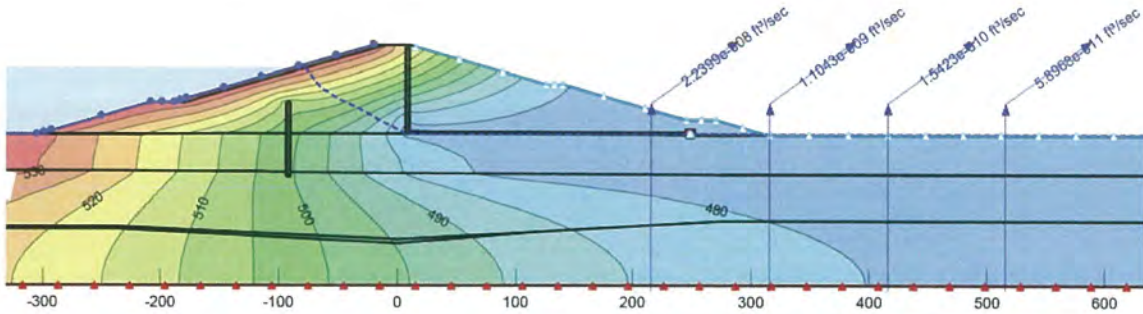

STEADY-STATE SEEPAGE —100-YEAR FLOOD ELEVATION (540 FT-MSL)

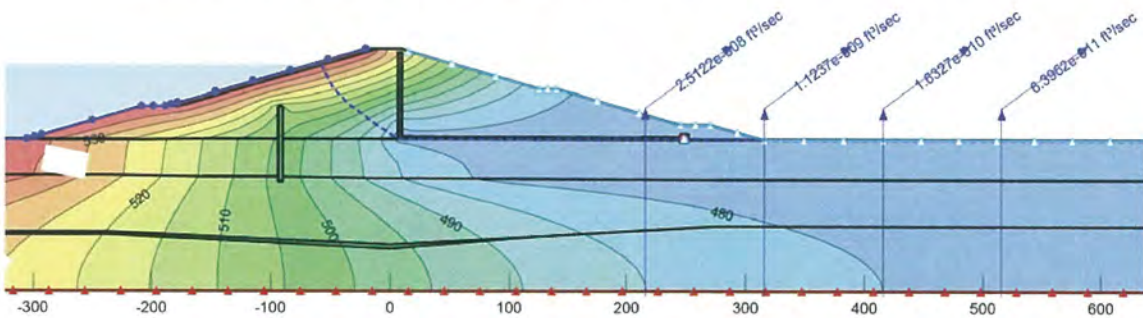

STEADY-STATE SEEPAGE —500-YEAR FLOOD ELEVATION (542 FT-MSL)

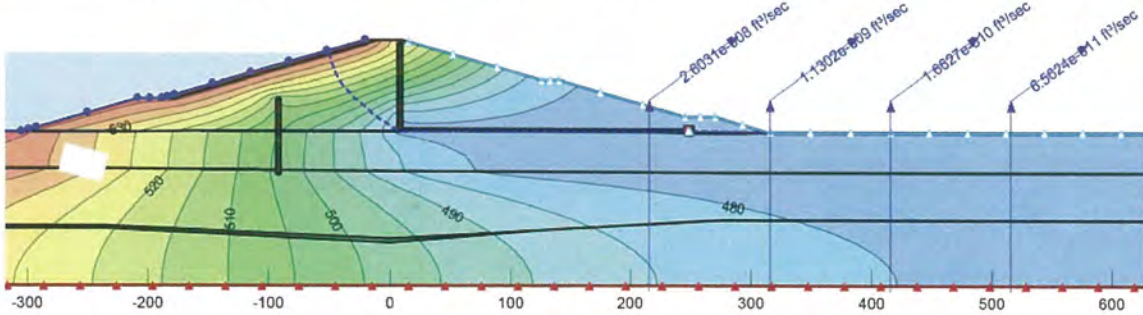

STEADY-STATE SEEPAGE —PMF ELEVATION (550 FT-MSL)

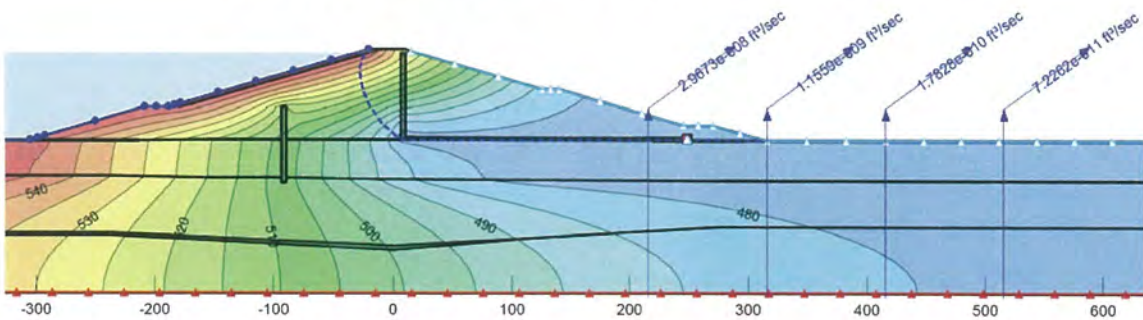

FNI PROJECT: NTD13565
 FILE: T:\GEO\2.31 - Numerical Modeling\
 DATE: Nov. 16, 2015
 PREPARED: HS/MTM

FREESSE AND NICHOLS
 4055 INTERNATIONAL PLAZA, STE. 200
 FORT WORTH, TX 76109

NORTH TEXAS MUNICIPAL WATER DISTRICT
LOWER BOIS D'ARC CREEK RESERVOIR
 SEEPAGE AND SLOPE STABILITY ANALYSIS
 SECTION AT STATION 78+00

PLATE
 15

STATION 78+00 SLOPE STABILITY RESULTS

END OF CONSTRUCTION
UPSTREAM SIDE

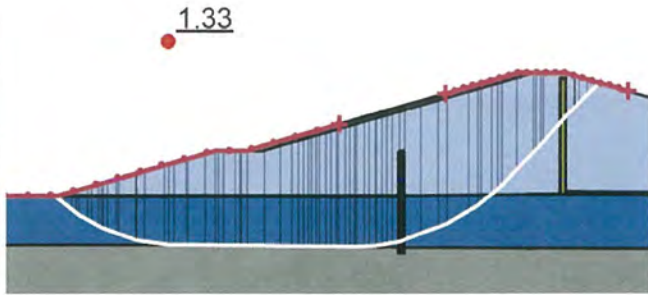

END OF CONSTRUCTION
DOWNSTREAM SIDE

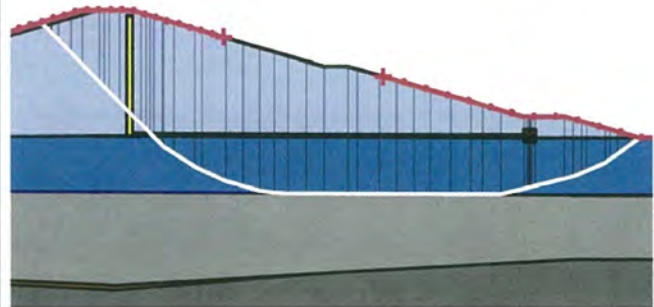

STEADY-STATE, NORMAL POOL ELEV. 534 FT-MSL
UPSTREAM SIDE

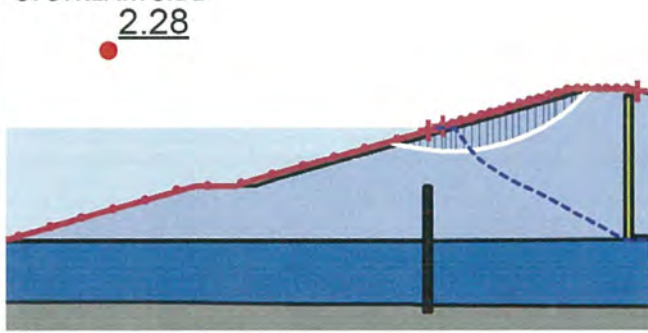

STEADY-STATE, NORMAL POOL ELEV. 534 FT-MSL
DOWNSTREAM SIDE

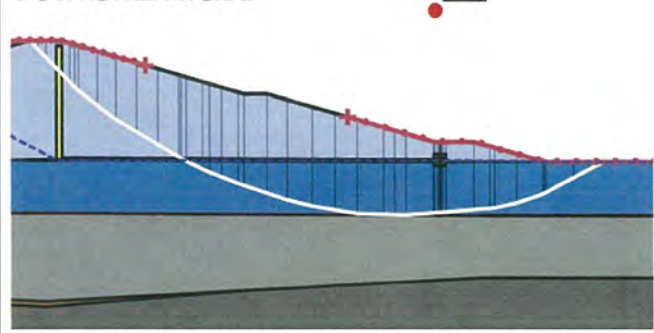

STEADY-STATE, 100-YR POOL ELEV. 540 FT-MSL
UPSTREAM SIDE

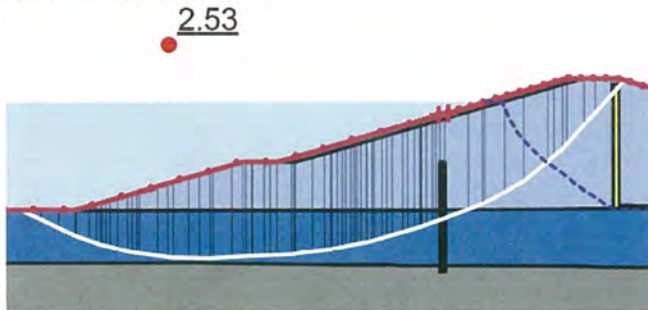

STEADY-STATE, 100-YR POOL ELEV. 540 FT-MSL
DOWNSTREAM SIDE

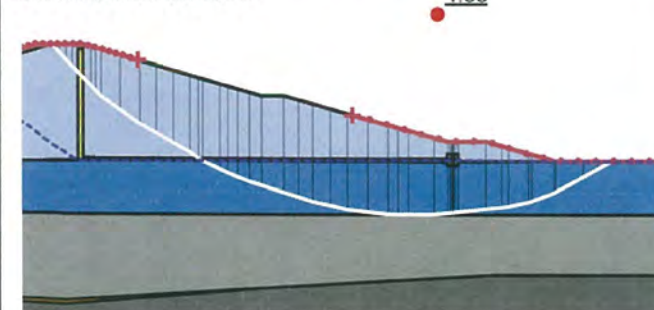

STEADY-STATE, 500-YR POOL ELEV. 542 FT-MSL
UPSTREAM SIDE

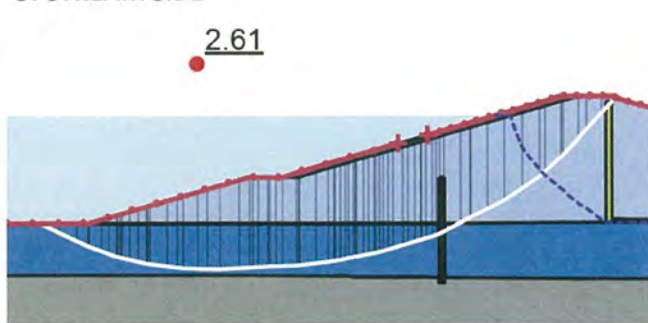

STEADY-STATE, 500-YR POOL ELEV. 542 FT-MSL
DOWNSTREAM SIDE

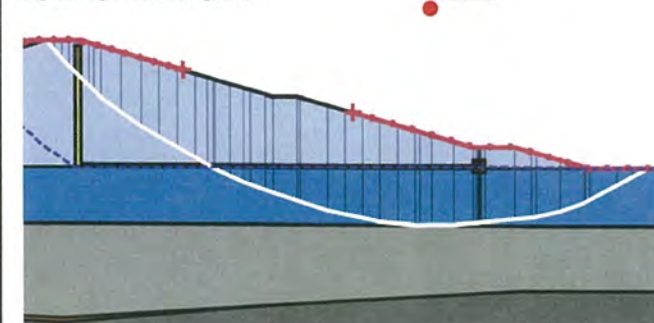

FNI PROJECT: NTD13565
FILE: T:\GEO\2.31 - Numerical Modeling\
DATE: Nov. 16, 2015
PREPARED: HS/MTM

FREESSE AND NICHOLS
4055 INTERNATIONAL PLAZA, STE. 200
FORT WORTH, TX 76109

NORTH TEXAS MUNICIPAL WATER DISTRICT
LOWER BOIS D'ARC CREEK RESERVOIR
SEEPAGE AND SLOPE STABILITY ANALYSIS
SECTION AT STATION 78+00

PLATE
16

STATION 78+00 SLOPE STABILITY RESULTS

STEADY-STATE, PMF POOL ELEV. 550 FT-MSL
UPSTREAM SIDE

2.91

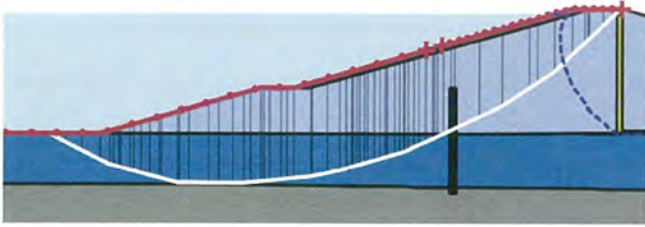

STEADY-STATE, PMF POOL ELEV. 550 FT-MSL
DOWNSTREAM SIDE

1.58

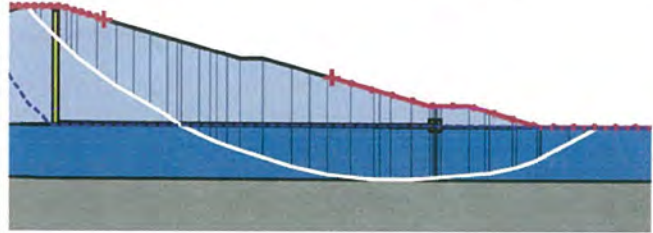

RAPID DRAWDOWN, NORMAL POOL TO BASE
UPSTREAM SIDE

1.33

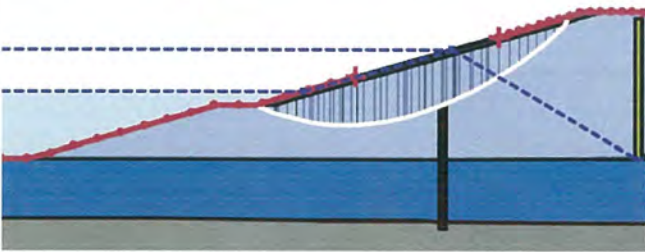

RAPID DRAWDOWN, 100-YR POOL TO NORMAL POOL
DOWNSTREAM SIDE

1.75

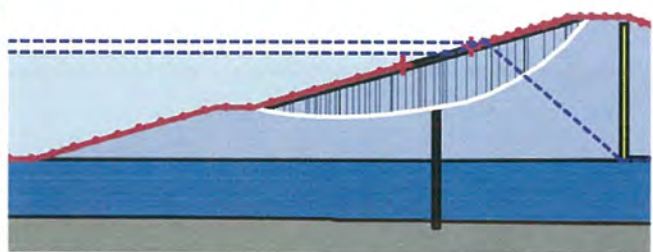

RAPID DRAWDOWN, 500-YR POOL TO NORMAL POOL
UPSTREAM SIDE

1.71

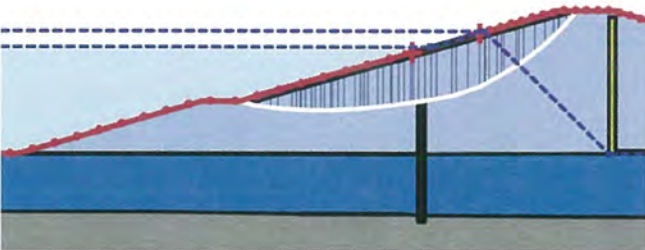

RAPID DRAWDOWN, PMF POOL TO NORMAL POOL
DOWNSTREAM SIDE

1.59

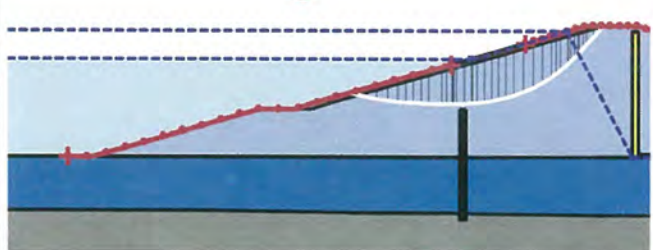

FNI PROJECT: NTD13565

FILE: T:\GEO\2.31 - Numerical Modeling\

DATE: Nov. 16, 2015

PREPARED: HS/MTM



**FREESSE
&
NICHOLS**
4055 INTERNATIONAL PLAZA, STE. 200
FORT WORTH, TX 76109

NORTH TEXAS MUNICIPAL WATER DISTRICT

LOWER BOIS D'ARC CREEK RESERVOIR

SEEPAGE AND SLOPE STABILITY ANALYSIS

SECTION AT STATION 78+00

PLATE
17

APPENDIX C
Structural Calculations
[NOT INCLUDED]

PAARD #54

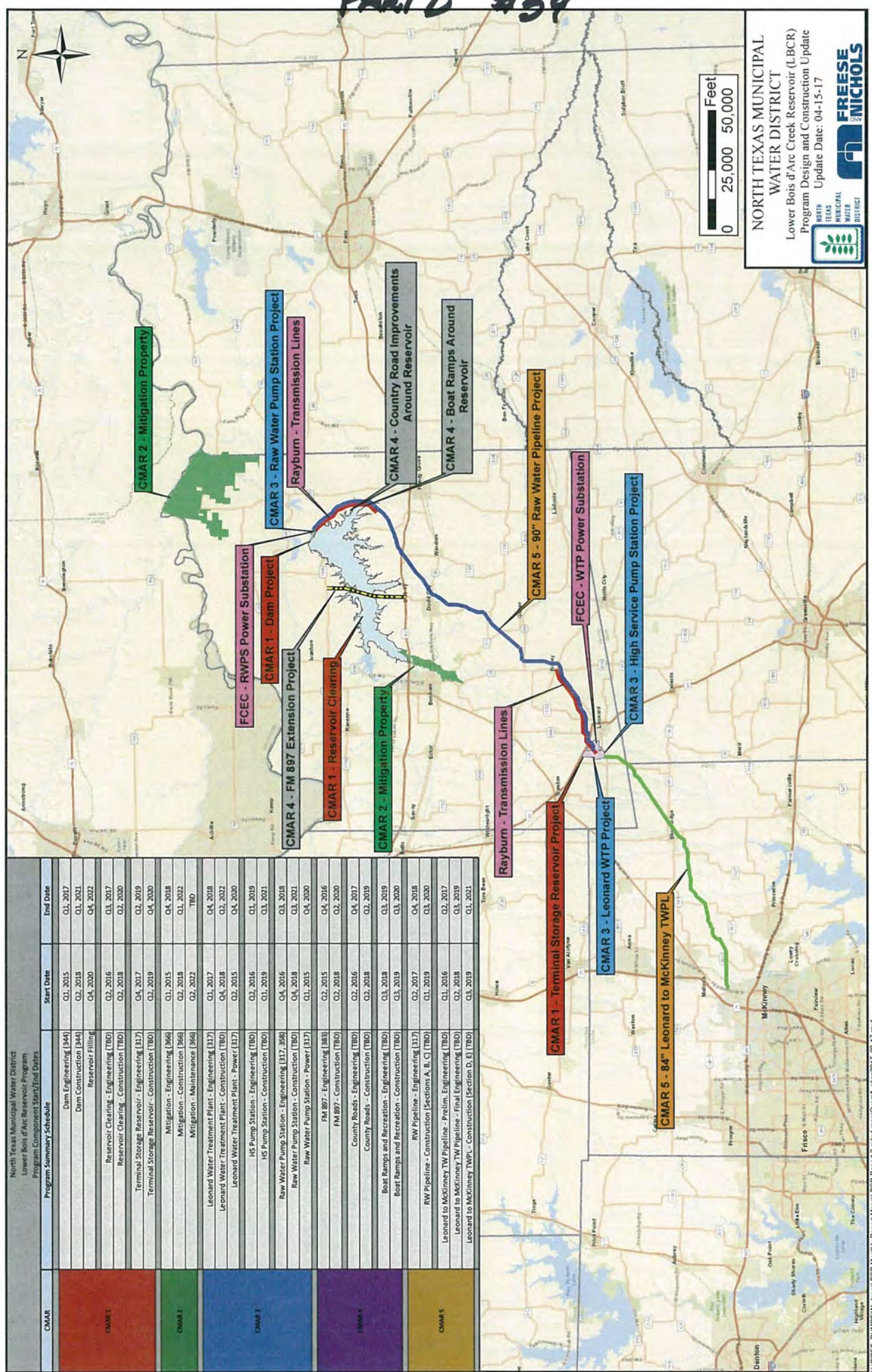

NORTH TEXAS MUNICIPAL WATER DISTRICT
 Lower Bois d'Arc Creek Reservoir (LBCR)
 Program Design and Construction Update
 Update Date: 04-15-17

CMAR	Program Summary Schedule	Start Date	End Date
CMAR 1	Dam Engineering (344)	Q1, 2015	Q1, 2017
	Dam Construction (344)	Q2, 2018	Q1, 2021
	Reservoir Filling	Q4, 2020	Q4, 2022
	Reservoir Clearing - Engineering (TBD)	Q2, 2016	Q3, 2017
CMAR 2	Reservoir Clearing - Construction (TBD)	Q2, 2018	Q2, 2020
	Terminal Storage Reservoir - Engineering (317)	Q4, 2017	Q2, 2019
	Terminal Storage Reservoir - Construction (TBD)	Q2, 2019	Q4, 2020
	Mitigation - Engineering (366)	Q1, 2015	Q4, 2018
CMAR 3	Mitigation - Construction (366)	Q2, 2018	Q1, 2022
	Mitigation - Maintenance (366)	Q2, 2022	TBD
	Leonard Water Treatment Plant - Engineering (337)	Q1, 2017	Q4, 2018
	Leonard Water Treatment Plant - Construction (TBD)	Q4, 2018	Q2, 2022
CMAR 4	Leonard Water Treatment Plant - Power (337)	Q2, 2015	Q4, 2020
	H5 Pump Station - Engineering (TBD)	Q2, 2016	Q1, 2019
	H5 Pump Station - Construction (TBD)	Q1, 2019	Q3, 2021
	Raw Water Pump Station - Engineering (317, 358)	Q4, 2016	Q3, 2018
CMAR 5	Raw Water Pump Station - Construction (TBD)	Q4, 2018	Q3, 2021
	Raw Water Pump Station - Power (317)	Q1, 2015	Q4, 2020
	FM 897 - Engineering (383)	Q2, 2015	Q4, 2016
	FM 897 - Construction (TBD)	Q2, 2018	Q2, 2020
FCEC	County Roads - Engineering (TBD)	Q2, 2016	Q4, 2017
	County Roads - Construction (TBD)	Q2, 2018	Q2, 2019
	Boat Ramps and Recreation - Engineering (TBD)	Q3, 2018	Q3, 2019
	Boat Ramps and Recreation - Construction (TBD)	Q3, 2019	Q3, 2020
CMAR 3	RW Pipeline - Engineering (317)	Q2, 2017	Q4, 2018
	RW Pipeline - Construction (Sections A, B, C) (TBD)	Q1, 2019	Q3, 2020
	Leonard to McKinney TW Pipeline - Prelim. Engineering (TBD)	Q1, 2016	Q2, 2017
	Leonard to McKinney TW Pipeline - Final Engineering (TBD)	Q2, 2018	Q3, 2019
CMAR 5	Leonard to McKinney TWPL - Construction (Section D, E) (TBD)	Q3, 2019	Q1, 2021

LOCATION MAP

SWIFT Funding Information

North Texas Municipal Water District

Lower Bois D'Arc Creek Reservoir
Project No. 317

Vol. 3

- Part D #54 Final - CMAR 5 - Raw Water PL & Leonard WTP
to McKinney Treated Water PL
- Part D #54 LBCR Comprehensive Plan Final
- Part D #54 Final - CMAR 1 - Reservoir Dam and Intake
Project

CONFORMED

**PART D
#54**

North Texas Municipal Water District

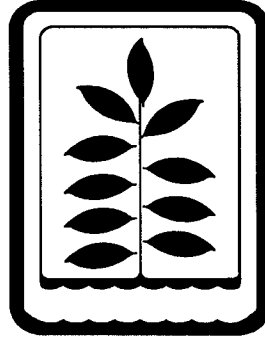

REQUEST FOR PROPOSALS

CONSTRUCTION MANAGER AT RISK

**LOWER BOIS D' ARC CREEK RESERVOIR PROGRAM-
RAW WATER PIPELINE AND TREATED WATER PIPELINE FROM THE
LEONARD WATER TREATMENT PLANT
TO MCKINNEY NO. 4 PROJECT**

Project No. 424 and Project No. 425

Freese and Nichols Project No. NTD14624



DOCUMENTS ISSUED FOR CONSTRUCTION

These "Issued for Construction" Contract Documents have been prepared by revising the Bidding Documents to record references to addenda.

The Bidding Documents may have been revised to incorporate these revisions directly into the "Issued for Construction" Contract Documents. Contractor is responsible for determining that these documents are consistent with their understanding of the Bidding Documents as modified per the appropriate provisions of the Contract Documents. The Bidding Documents, as modified per the appropriate provisions of the Contract Documents, take precedence over these "Issued for Construction" documents.

00 01 10 TABLE OF CONTENTS

Division / Section	Title
Division 00	Request for Proposals and Contracts
00 01 10	Table of Contents
00 11 19	Request for Proposals
00 21 16	Instructions for Proposers
00 30 00	Available Background Information
00 42 23	Proposal Transmittal Form
00 42 23.01	Cost Proposal
00 42 23.02	Updated SOQ Information
00 42 23.03	CMAR Services Man Hour Level of Effort
00 43 43	Wage Rates
00 45 16	Technical Proposals
00 52 23	Construction Management At Risk Services Agreement
00 52 23.01	Treatment Plan for Inadvertent Discovery of Native American Human Remains Or Unmarked Burials During Archaeological Investigations Of The Area Of Potential Effect (APE) For The Proposed Lower Bois d' Arc Reservoir An Agreement Between The North Texas Municipal Water District The U.S. Army Corps Of Engineers, Tulsa District The Texas Historical Commission
00 52 23.02	Treatment Plan An Agreement Between North Texas Municipal Water District The U.S. Army Corps Of Engineers, Tulsa District The Texas Historical Commission And The Caddo Nation of Oklahoma
00 72 00	Standard General Conditions of the Construction Contract
00 91 13	Addenda
Division 01	General Requirements
01 01 01	Construction Manager at Risk Services
01 11 00	Summary of Work
01 29 00	Payment Procedures
01 31 00	Project Management and Coordination
01 31 13	Project Coordination
01 31 13 13	Forms
01 32 16	Construction Progress Schedule
01 32 34	Video and Photographic Documentation
01 33 00	Submittal Procedures

Division / Section	Title
01 33 00 01	Table of Required Submittals
01 35 00	Special Procedures
01 40 00	Quality Requirements
01 45 16.16	Hydrostatic Testing
01 50 00	Temporary Facilities and Controls
01 57 00	Temporary Controls
01 70 00	Execution and Closeout Requirements
01 74 00	Final Cleaning
01 75 00	Starting and Adjusting
01 78 23	Operation and Maintenance Data
Appendix A	<ol style="list-style-type: none"> 1. Design Report for Lower Bois d' Arc Creek Reservoir Raw Water Pipeline (Project No. 317). 2. Leonard WTP To McKinney No. 4 Treated Water Pipeline – Pipeline Corridor Selection Technical Memorandum. 3. Updated Raw Water Pipeline Route 4. Updated Treated Water Pipeline Route

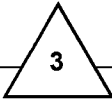

END OF SECTION

00 11 19 REQUEST FOR PROPOSAL

ARTICLE 1: GENERAL NOTICE

1.01 The North Texas Municipal Water District (“Owner” and “District”) extends this Request For Proposals (“RFP”) to solicit a response (“Proposal”) from each of the firms (collectively “Proposers”, individually “Proposer”) identified in Section 1.09 below for Construction Manager at Risk Services for the construction of:

A. Lower Bois d’ Arc Creek Reservoir (LBCR) Program – Raw Water Pipeline and Treated Water Pipeline from the Leonard Water Treatment Plant to McKinney No. 4 Project (“Project”), North Texas Municipal Water District Project No. 424 and Project No. 425. The Project consists of:

1. The raw water transmission line will be a 90-inch diameter pipe that extends approximately 40 miles from the raw water pump station to the terminal storage reservoir at the Leonard Water Treatment Plant site in Leonard, Texas.
2. The treated water from Leonard WTP to No. 4 McKinney will be an 84-inch diameter pipe approximately 25 miles in length that extends from the Leonard Water Treatment Plant to the McKinney Number 4 delivery point in McKinney, Texas.
3. Available background information on the Project is included in this RFP and can be found in Appendix A.

1.02 Conceptual Project Cost

A. The conceptual construction cost value of the raw water pipeline is approximately \$170.9 million dollars. The conceptual construction cost value of the treated water pipeline from Leonard Water Treatment Plant to McKinney No. 4 is approximately \$108.2 million dollars. **For purposes of the RFP the Owner’s budget for the Project is \$279.1 million.**

1.03 Conceptual Schedule

A. For purposes of the Proposal, the preconstruction and procurement services periods will be as follows:

1. Raw Water Pipeline – Start January 2017 and finish January 2019.
2. Treated Water Pipeline from Leonard Water Treatment Plant to McKinney No. 4 – Start September 2017 and finish July 2019.

B. Pending permit approvals, the Owner anticipates that construction of the raw water pipeline will be initiated in February 2019 and be completed by August 2020. It is also anticipated that the initiation of construction of the treated water pipeline from Leonard Water Treatment Plant to McKinney No. 4 will be in the August 2019 and be completed February 2021.

1.04 Existing Design

A. The Raw Water Pipeline Design.

1. The route study and route selection has been completed. Design is estimated to be near 30% and is currently suspended pending CMAR selection
- B. Treated Water Pipeline from Leonard WTP to No. 4 McKinney Design.
 1. The route study and route selection for is underway. 30% design is expected to be completed by late spring of 2017.
- C. The CMAR will be coordinating the design effort for this Project with multiple pipeline designers.
 1. The raw water pipeline will be separated into three (3) segments with each segment having a design engineer. Freese and Nichols, Inc., Lockwood, Andrews & Newnam, Inc. and Black & Veatch are the design engineers.
 2. The treated water pipeline will be separated into two (2) segments with each segment having a design engineer. The procurement process for the selection of these engineers is currently on hold.

1.05 Permitting Status

- A. All construction phases of the Lower Bois d' Arc Creek Reservoir project require that North Texas Municipal Water District first obtain a 404 Permit (Clean Water Act, Section 404) from the U.S. Army Corps of Engineers. The District has applied for this permit and the supporting documents and reports are currently under review by the Corps and other federal agencies.
- B. The District is using all means available to secure a final decision and 404 Permit issuance sometime in Calendar Year 2017. However, April 2018 is more likely. Construction will be initiated as soon as practicable after the 404 Permit is issued. The complex nature of the review process may result in additional delays beyond April 2018 of unknown duration.
- C. The District is endeavoring to expedite the review process but cannot accurately predict an exact date for obtaining the 404 Permit. There is therefore the potential that permit issuance delays could allow the preconstruction services phase services to be completed as well as some amount of the procurement phase services (i.e. initial work packages prepared and ready to be issued) prior to the issuance of the 404 permit. The initiation of construction may then have to be delayed.
- D. This delay period is addressed in the Construction Management At Risk Services Agreement at Section 20.06. Proposers are requested to comment upon that and any other concern or question it has related to the requirements of the RFP, the Agreement and the General Conditions as it pertains to this potential delay. **Such comments will be included on 00 42 23.02 Proposal Form 2.**

1.06 Construction Manager At Risk (CMAR) Services

- A. Construction Manager At Risk services consist of preconstruction, procurement and construction services as more fully described in Section 01 01 01 Construction Manager at Risk Services, ("Services").

- 1.07 The evaluation criteria and weighting are further described in 00 21 16 Instructions For Proposers. The Owner intends to enter into a CMAR Agreement (“Agreement”), a copy of which is included in this RFP.
- 1.08 The procurement and the provision of CMAR Services will be in accordance with Texas Government Code Chapter 2269 and this RFP. Performance and Payment Bonds will be required before construction of the Project begins. **Proposal Security in the form of a Bid Bond is required to be submitted with the Proposal.** The Bid Bond of the selected Proposer will be held as security until Performance and Payment bonds are provided.
- 1.09 The Owner advertised for Statement of Qualifications (“SOQs”) with the release of the Request For Qualifications (“RFQ”) on April 20, 2016. SOQs were received on May 27, 2016. The Owner’s selection committee evaluated and ranked the SOQs in accordance with the published evaluation criteria and weighting as included in the RFQ. The highest ranked Proposers were short-listed to receive this RFP, i.e. shortlisted Proposers.

ARTICLE 2: EXAMINATION OF DOCUMENTS

- 2.01 The RFP and Proposal information for the Project can be downloaded, free of charge, from <https://www.e-builder.net> . Potential Proposers will receive an invitation to the Project with a link. It is the downloader’s responsibility to determine that a complete set of documents, as defined in the Instructions for Proposers and the Agreement are received.
- 2.02 Proposers can have additional company personnel authorized for access to the website. Please provide names and e-mail addresses to Jane Jenks at jane.jenks@freese.com .
- 2.03 This website will be updated periodically with Addenda, procurement and RFP information, questions/responses, and other information relevant to the procurement of the Project. Proposers are encouraged to routinely monitor the website.

ARTICLE 3: DELIVERY OF PROPOSALS AND PROCUREMENT SCHEDULE

- 3.01 For a Proposal to be accepted, deliver Proposal to the address shown below no later than 2:00 p.m. on October 28, 2016 at the District Office’s at 505 E. Brown Street, Wylie Texas 75098. In accordance with Texas law, the names of Proposers submitting a Proposal and the fees and costs stated in each Proposal will be read aloud at this time and place. There will be no further discussion of the Proposals or the procurement process and no questions or comments will be received at this time and place. Proposals received after this time will be returned unopened. Address Proposals to:

President and Board of Directors
North Texas Municipal Water District
505 E. Brown Street
Wylie, Texas 75098

3.02 **Procurement Schedule**

Activity	Date (2016/2017)
Issue RFP	September 7
Proposal Preparation Period	September 7 – October 28
Submission of Proposals	October 28
Review and Evaluation of Proposals	October 28- December 5
Interviews (Proposers please hold dates)	November 29-30
Selection Notification	December 5
Board Approval	January 2017 Meeting

3.03 The Owner assumes no obligations, responsibilities and liabilities, fiscal or otherwise, to reimburse all or part of the costs incurred or alleged to have been incurred by parties considering a response to and/or responding to this RFP. All such costs shall be borne solely by each Proposer.

ARTICLE 4: AWARD OF AGREEMENT

4.01 It is the intent of the Owner to award the Agreement to the Proposer who provides the best value Proposal for the Project based on the selection criteria, weighting and its ranking evaluation. The Owner will attempt to negotiate an agreement with the selected Proposer. If the Owner is unable to negotiate a satisfactory agreement with the selected Proposer, the Owner will, formally and in writing, end negotiations with that Proposer and proceed to negotiate with the next Proposer in the order of the selection ranking until an agreement is reached or negotiations with all Proposers end.

ARTICLE 5: POINT OF CONTACT FOR QUESTIONS REGARDING PROCUREMENT PROCESS AND COMMUNICATION PROTOCOL

5.01 To ensure fairness during the procurement process, until the Agreement is executed, Proposers and their employees, representatives and agents shall not contact an Owner staff, member of selection committee, Owner Board member, or any other official, employee, representative or consultant (identified immediately below) of the Owner involved with this procurement process other than the Point of Contact identified in this RFP.

A. Owner Representatives and Consultants

1. Freese and Nichols, Inc.
2. Black & Veatch
3. Lockwood, Andrews & Newnam

5.02 Questions regarding this RFP and Project are to be submitted using the website, under the Questions/Responses tab in the Project menu. Modifications to the RFP prior to the award of the Agreement can only be made by Addenda.

Point of Contact:
Douglas Herbst
Freese and Nichols, Inc.
Website: <https://www.e-builder.net>

- 5.03 All communications are subject to distribution to all Proposers except that Owner will endeavor to prevent disclosure to other Proposers' information unique to a particular Proposer or otherwise identified as proprietary or confidential by a Proposer. The Owner will share with all Proposers all questions and responses and all Addenda to this RFP including any revisions based on its review of Proposer comment and questions concerning this RFP. The Owner disclaims the accuracy of information derived from any source other than the Point of Contact identified above, and the use of any such information is at the sole risk of the Proposer. Only answers and responses issued by formal Addenda shall be final and binding upon the Owner. Oral and other interpretations shall be without legal effect and Proposer shall not rely on such oral and other interpretations.

END OF SECTION

00 21 16 INSTRUCTIONS FOR PROPOSERS

ARTICLE 1: DEFINED TERMS

- 1.01 Terms used in the RFP will have the meanings indicated in this RFP or in the General Conditions.
- A. CMAR Team means the team formed by the Proposer for purposes of responding to the RFQ and the RFP.
 - B. CMAR Team Member means a corporate entity of firm or individual included in the CMAR Team and identified in the SOQ and Proposal that will provide any of the Services for this Project.
 - C. Proposer means the corporate entity or firm that was a shortlisted Proposer and that submits the Proposal and if selected for the Project will execute the Agreement.
 - D. Program Manager means Freese and Nichols, Inc.

ARTICLE 2: PROPOSALS RECEIVED

- 2.01 Refer to the RFP for information on receipt of Proposals.

ARTICLE 3: COPIES OF RFP

- 3.01 Obtain a complete RFP as indicated in the RFP.
- 3.02 Use complete RFP in preparing Proposals; Owner assumes no responsibility for errors or misinterpretations resulting from the use of an incomplete RFP.
- 3.03 Owner will make copies of RFP available on the above terms only for the purpose of obtaining Proposals for completion of the Services and does not confer a license or grant permission or authorization for any other use.

ARTICLE 4: PROPOSALS

- 4.01 Proposers are required to submit a Proposal for consideration in award of the Agreement for the Services.

ARTICLE 5: EXAMINATION OF RFP

- 5.01 Before submitting a Proposal:
- A. Examine and carefully study the RFP, including any Addenda and the related supplemental data identified in the RFP.
 - B. Become familiar and satisfied with all federal, state, and local Laws and Regulations that may affect cost, progress, or the completion of Work.
 - C. Carefully study and correlate the information known to Proposer with the RFP, Addenda and the related supplemental data identified in the RFP or Contract Documents.
 - D. Promptly give Point of Contact written notice of all conflicts, errors, ambiguities, or discrepancies that Proposer discovers in the RFP, Addenda and the related supplemental data. Determine that the RFP, Addenda and the related supplemental data are generally

sufficient to indicate and convey understanding of all terms and conditions for completion of the Services.

ARTICLE 6: INTERPRETATIONS AND ALTERNATE PROPOSALS

- 6.01 Submit all questions about the meaning or intent of the RFP, Addenda and the related supplemental data to the Point of Contact as indicated in the RFP. Interpretations, clarifications and responses considered necessary by the Owner in response to such questions will be responded to on the web site or issued by Addenda. Addenda will be posted on web site. Questions received less than 9 days prior to the date for opening of Proposals may not be answered. Submit any offer of alternate terms and conditions, or offer of Services not in strict compliance with the RFP to the Point of Contact no later than the deadline stated immediately above. Owner will issue Addenda as appropriate if any of the proposed changes to the RFP are accepted. A Proposal submitted with clarifications or taking exceptions to the Contract Documents, except as modified by Addenda, may be rejected.

ARTICLE 7: PROPOSAL SECURITY

- 7.01 **A Proposal must be accompanied by Proposal Security in the form of an acceptable Bid Bond in the name of the Owner for each Proposal.** The Bid Bond must be issued by a surety legally authorized to do business in the State of Texas, is listed in the Department of Treasury's Circular 570 and has an A.M. Best Company Rating of A-VIII or better.

Provide a Bid Bond in the amount of thirteen million nine hundred and fifty-five thousand dollars (\$13,955,000). The Bid Bond amount is 5 percent of the Owner's budget of \$279.1 million.

- 7.02 The Bid Bond of the selected Proposer will be retained as security until Performance and Payment Bonds for either 100 percent of the Owner's budget or the Guaranteed Maximum Price have been provided. This Bid Bond will be returned when the Performance and Payment Bonds are provided. The Proposal Security of other Proposers whom Owner believes to have a reasonable chance of receiving the award may be retained by Owner until the earlier of 7 days after the Effective Date of the Agreement or 90 days after the date Proposals are opened.

ARTICLE 8: CONTRACT TIMES

- 8.01 See applicable provisions in the Agreement.

ARTICLE 9: LIQUIDATED DAMAGES

- 9.01 Provisions for Liquidated Damages are set forth in the Agreement.

ARTICLE 10: RETAINAGE

- 10.01 Provisions concerning Proposer's rights to deposit securities and or retainage are set forth in the Agreement.

ARTICLE 11: PROPOSAL FORMS

- 11.01 Proposal Forms are included in the RFP. Proposal Form 1 is in PDF format. A copy of Proposal Forms 2 through 3 in Word or Excel will be made available to Proposers. Proposers shall complete and submit with its Proposal all Proposal Forms.
- 11.02 Proposal Transmittal Form (Proposal Form 1)
- A. Complete all blanks on the Proposal Transmittal Form, Proposal Form 1. Execute Proposal Form 1 as indicated below:
1. For a corporation in the corporate name with the signature of the president, a vice-president or other corporate officer accompanied by evidence of authority of the individual to sign on behalf of the corporation. Show the corporate address and state of incorporation with the signature.
 2. For a partnership in the partnership name with the signature of a partner. The title of the partner must appear with the signature. The document must be accompanied by evidence of authority for that individual to sign on behalf of the partnership. Show the official address of the partnership with the signature.
 3. For a limited liability company in the name of the firm with the signature of an officer of that company. The document must be accompanied by evidence of authority for that individual to sign on behalf of the company. Show the state in which the firm was formed and the official address of the firm with the signature.
 4. For a joint venture with a signature of an authorized person from each joint venturer in the manner indicated on the Proposal Transmittal Form. The document must be accompanied by evidence of authority for each individual to sign on behalf of their respective organizations. Show the official address of the joint venture with the signature.
- B. Type or print all names in ink below the signature.
- C. Acknowledge receipt of all Addenda by filling in the number and date of each Addenda received. Provide a signature as indicated to verify that the Addenda were received. A Proposal Transmittal Form that does not acknowledge the receipt of all Addenda may be considered non-responsive.
- D. Acknowledge that all information and statements in the Statement of Qualifications remains true and accurate or certain information is no longer true and accurate. If the later, Proposer shall provide the updated information that is true and accurate on 00 42 23.02- Proposal Form 2.
- E. Provide the name, address and telephone number of the individual to be contacted for any communications regarding the Proposal in the Proposal Transmittal Form.
- F. Include the required Proposal Form 1 attachments with Proposal Form 1.

ARTICLE 12: CONFIDENTIALITY OF PROPOSAL INFORMATION

- 12.01 In accordance with Texas Government Code 552.110 trade secrets and confidential information in Proposals are not open for public inspection. Proposals will be opened in a manner that avoids disclosure of the contents to competing Proposers and keeps the Proposals secret during

considerations. All Proposals are open for public inspection after the Agreement is awarded, but trade secrets and confidential information in Proposals are not typically open for public inspection. The Owner will protect this information to the extent allowed by law. Clearly indicate which specific documents are considered to be trade secrets or confidential information by stamping or watermarking all such documents with the word "confidential" prominently on each page or sheet or on the cover of bound documents. Place "confidential" stamps or watermarks so that they do not obscure any of the required information on the document, either in the original or in a way that would obscure any of the required information in a photocopy of the document. Photocopies of "confidential" documents will be made only for the convenience of the selection committee and will be destroyed after the Effective Date of Agreement. Original confidential documents will be returned to the Proposer after the Effective Date of Agreement if the Proposer indicates that the information is to be returned with the Proposal, and directions for its return are provided by the Proposer.

ARTICLE 13: SUBMITTAL OF PROPOSALS

13.01 The Proposal shall consist of two separate parts the Technical Proposal and the Cost Proposal. The Proposer shall complete and submit the Technical Proposal per Section 00 45 16 and the Cost Proposal as per Section 00 42 23.01.

A. The Technical Proposal shall be submitted in the following format and subject to the page limits as indicated:

Cover Letter.

Section 1: Section 00 42 23 Proposal Transmittal Form (Proposal Form 1) and attachments - **Bid Bond** and Section 00 42 23.02 (Proposal Form 2).

Section 2: Project Management and Execution Approach.

Section 3: Preconstruction and Procurement Services Plan.

Section 4: Construction Services Plan.

Section 5: Quality Control Plan and Risk Management Plan.

B. The Cost Proposal shall be submitted and include:

00 42 23.01 Cost Proposal.

00 42 23.03 (Proposal Form 3)- CMAR Services Man Hour Level of Effort.

C. Except for charts, schedules, exhibits and other illustrative and graphical information, all information shall be prepared on 8.5" x 11" white paper, except where specifically excepted in this RFP. Charts, schedules, exhibits and other illustrative and graphical information may be on 11" x 17" paper, but must be folded to 8.5" x 11". An 11" x 17" sheet shall be counted as one page provided it is a chart, exhibit or other illustrative and graphical information.

All printing, except for the front cover of the Proposal and any appendices, must be a font of not less than 11-point and be double-sided. A double-sided page shall be considered two (2) pages for purposes of the page limitations. The Proposal covers-front and back and section dividers with tabs will not count as pages for purposes of page limitations. Any plan sheets or drawing submitted shall be drawn to an identifiable scale and submitted on 11" x 17" sheets. Audio visual materials including audio tapes, video tapes and CD-ROM material will not be accepted.

D. Proposers are instructed to limit the information included in the Proposal to the information required and necessary to meet such requirements. Proposals should be prepared in a straightforward and concise manner. The Owner is not interested in receiving marketing brochures, promotional material, generic narratives, elaborate binding, colored displays, etc. in the Proposals. Emphasis should be placed on clarity and completeness of content and responsiveness to the RFP requirements.

E. Proposal Forms

Proposal Forms		
Proposal Form Number	Title	Proposal Submittal Location
1	Proposal Transmittal Form	Technical Proposal Section 1, Proposal Transmittal Form
2	00 42 23.02 Updated SOQ Information and 404 Permit Delay Commentary	Technical Proposal Section 1, Proposal Transmittal Form
3	00 42 23.03 CMAR Services Man Hour Level of Effort	Cost Proposal

F. Proposer shall provide one (1) original Proposal and seven (7) printed copies of the Proposal.

G. Proposer shall also provide one digital copy of the Proposal in portable document format (pdf) on a compact disk or other media that will allow files to be shared by the Owner's selection committee. The Proposal is to be a single file that will print to match the printed copy provided. Confidential information may be provided in a separate file, provided that file is referenced in the Proposal.

H. Proposer shall enclose the Technical Proposal(s) and Cost Proposal(s) in separate opaque sealed envelopes plainly marked with the Project name, the name and address of the Proposer. Address an outer envelope to the mailing address shown in the Request for Proposals and enclose the sealed packages containing the Technical Proposal(s), the Cost Proposal(s) and the digital copy of the Proposal. The Proposer assumes full responsibility for ensuring that the Proposal arrives at the prescribed location before the prescribed time.

ARTICLE 14: INTERVIEWS

14.01 The Owner will conduct interviews with all Proposers to provide Proposers a better opportunity to demonstrate they can provide the best value to the Owner for this Project.

A. The Owner will notify the Proposers of:

1. The time and place for the interview.
2. Interview format and agenda.
3. Individuals will be identified that are expected to participate in the interview.

14.02 Failure to participate in the interview will result in disqualification from consideration for the Project.

ARTICLE 15: WITHDRAWAL OF PROPOSAL

15.01 A Proposer may withdraw its Proposal by providing a written request duly executed by an authorized representative and delivered to the Owner at any time prior to the Proposal submittal deadline or within 24 hours after Proposals are opened. If withdrawal is after the Proposals are opened, the written request shall demonstrate to the reasonable satisfaction of the Owner that there was a material and substantial mistake in the preparation of its Proposal. The Proposal security will be returned if it is clearly demonstrated to the Owner that there was a material and substantial mistake in its Proposal. A Proposer that requests to withdraw its Proposal under these conditions may be disqualified from responding to a reissued Request for Proposals for the Services to be furnished under this RFP.

ARTICLE 16: OPENING OF PROPOSALS

16.01 Proposals will be publicly opened at the time and place indicated in this RFP. Owner will publicly acknowledge receipt of Proposals received in time to be considered. The Owner will read aloud names of each Proposer and any fees and costs that are associated with the Proposal as required by Texas law. A summary of the amounts on the Cost Proposal will be made available to Proposers, upon request, after the Agreement has been awarded.

ARTICLE 17: EVALUATION OF PROPOSALS

17.01 Within 45 days after the date of opening the Proposals, the Owner will evaluate, score and rank each Proposal with respect to the evaluation criteria and weighting described in this RFP. In evaluating Proposals, Owner will consider whether or not the Proposals fully comply with the RFP submittal requirements.

17.02 The Proposals will be evaluated using the criteria indicated in the table below.

Evaluation Criteria	RFP Location	Weight
The Project Management and Execution Approach	00 45 16 Section 2.03.	15
Preconstruction and Procurement Services Plan	00 45 16 Section 2.04A.	20
Construction Services Plan	00 45 16 Section 2.04B.	15
Quality Control Plan and Risk Management Plan	00 45 16 Section 2.04C.	10
Interview		10
Cost Proposal	00 42 23.01	30
Total		100

- 17.03 The Owner will evaluate and score the Technical Proposal of each Proposer based on the criteria included in the RFP. The Owner will score the results of the interview.
- 17.04 The Owner will evaluate and score the Cost Proposal of each Proposer based on the costs proposed for the requested cost elements and the relative value received for the costs proposed. The Owner is not interested in any costs developed as part of a procurement strategy whereby and for example deep discounts for Preconstruction and Procurement Services are given. If Owner determines, in its sole discretion, that costs are below what is anticipated for this Project or the dollar amounts far below the other Proposers, the Owner reserves the right to declare that Cost Proposal non-responsive or seek additional information and justification for those costs prior to rendering a final decision on the responsiveness of that Cost Proposal.
- 17.05 The score of the Technical Proposal and the interview will be added to the score of the Cost Proposal for each Proposer and the Proposals will be ranked from highest to lowest score.
- 17.06 Material misstatements and/or inaccuracies in the information submitted in the Proposals that was relied upon for evaluation, scoring and ranking may be grounds for rejection of the Proposal for this Project. Any material misstatements and/or inaccuracies, if discovered after award of the Agreement may be grounds for immediate termination of the Agreement, at the Owner's sole discretion. Additionally, the Proposer will be liable to the Owner for any additional costs or damages to the Owner resulting from such misstatements and/or inaccuracies, including costs and attorney's fees for collecting such costs and damages.
- 17.07 Submission of a Proposal indicates Proposer's acceptance of the evaluation criteria and weighting contained in the RFP as well as Proposer's recognition and acknowledgement that subjective judgments must be made by the selection committee during the evaluation.

ARTICLE 18: AWARD OF CONTRACT

- 18.01 The Proposer selected for award of the Agreement will be the Proposer whose Proposal provides the best value to the Owner. The Owner is not bound to accept the lowest priced Cost Proposal.
- 18.02 Proposers shall only be allowed to submit one Proposal in which it has an interest in.

ARTICLE 19: CONTRACT SECURITY AND INSURANCE

- 19.01 The General Conditions set forth Owner's requirements as to performance and payment bonds and insurance.
- 19.02 When the successful Proposer delivers the executed Agreement to Owner, it must be accompanied by the required certificates of insurance.

ARTICLE 20: SIGNING OF AGREEMENT

- 20.01 The Notice of Award to the selected Proposer will be accompanied by the required number of unsigned counterparts of the Agreement with the other Contract Documents that are identified in the Agreement. The selected Proposer shall sign and deliver the required number of counterparts of the Agreement and attached documents to Owner within 15 days. Owner will deliver two fully signed counterparts to selected Proposer within 10 days after receiving the signed documents from the selected Proposer.

ARTICLE 21: AGREEMENT NOT TO BE ASSIGNED

21.01 The Agreement may not be assigned in whole or in part by the selected Proposer without the prior written consent of the Owner.

ARTICLE 22: SALES AND USE TAXES

22.01 City or state sales taxes should generally not be included in the Cost Proposal as the Owner qualifies as an exempt agency. Certain items such as rented equipment may be taxable even though the Owner is a tax exempt agency. The Proposer assumes responsibility for including any applicable sales taxes in the Cost Proposal and assumes responsibility for complying with all applicable statutes and rulings of the State of Texas Comptroller.

22.02 It is the Owner’s intent to have the Agreement qualify as a “separated contract.” In order for this Agreement to qualify:

- A. If awarded this Agreement, obtain a sales tax permit from the State of Texas Comptroller.
- B. If awarded this Agreement, the dollar value of materials exempt from the sales tax must be identified.

ARTICLE 23: WAGE RATES

23.01 A schedule listing the minimum wage rates for various classifications of laborers which have been established by the Owner for this Project are included in Section 00 43 43 “Wage Rates.” Proposers must pay not less than the minimum wage shown on this list and comply with all statutes and ruling of the State Comptroller.

ARTICLE 24: REQUIREMENTS FOR PROFESSIONAL SERVICES

24.01 Proposer shall secure any required services for the Project that are defined as professional services under the Professional Services Procurement Act, Chapter 2254 of the Texas Government Code (for example, registered professional land surveyors, professional architects and professional engineers using the qualifications based selection process prescribed by that Chapter.

ARTICLE 25: INSPECTION AND CONSTRUCTION MATERIALS TESTING

25.01 The CMAR will be required to provide quality control services in accordance with the contract documents. Independent of those CMAR services, and in accordance with Texas law, the Owner will provide or contract for inspection services, testing of construction material engineering and verification testing services necessary for acceptance of the Project. The CMAR will be required to provide management for coordination of these services.

ARTICLE 26: SELF PERFORMANCE AND CMAR TEAM MEMBER WORK

26.01 In accordance with Texas law, the CMAR may perform minor work that may be included in its general conditions for the Project. For the other Work, the CMAR may seek to self-perform Work if the CMAR submits a Bid in the same manner as all other trade Subcontractors or suppliers and if the Owner determines that the CMAR Bid provides the best value for the Project. The CMAR Team Members may seek to perform Work if the CMAR Team Member

submits a Bid in the same manner as all other trade Subcontractors or suppliers and if the Owner determines that the CMAR Team Member's Bid provides the best value for the Project.

- 26.02 At this time, the Owner contemplates that self-perform Work will be allowed for the Project and there will be no limitation as to the amount of self-perform Work the CMAR could undertake for the Project. There is also no limitation as to the amount of Work a CMAR Team Member could undertake.
- 26.03 Proposer shall indicate on in its Proposal in the Construction Services Plan (00 45 16 Section 2.04B) its intention to pursue self-perform Work for the Project and the intentions of any CMAR Team Member to pursue any of the Work. The narrative should include the specific types of Work and identification of the CMAR or Team Member(s) intending to perform the Work.
- 26.04 If a selected trade Subcontractor or CMAR Team Member defaults in the performance of its work or fails to execute subcontract after being selected the CMAR may, without advertising, fulfill the subcontract requirements itself or select a replacement trade Subcontractor.

ARTICLE 27: CONSTRUCTION SERVICES

- 27.01 The District is desirous of having a robust competitive environment for the procurement of the construction services and expects the CMAR to undertake activities to do so.
- 27.02 The District is desirous of providing the opportunity for the local contracting community to participate in this Project and expects the CMAR to undertake activities to enable the local contracting community to Bid on various Work packages for this Project.

ARTICLE 28: VALIDITY OF PROPOSALS

- 28.01 The offer represented by each Proposal will remain in full force and effect for ninety (90) days after the Proposal submission date. If the award of the Agreement has not been made by the Owner within ninety days (90) after the Proposal submission date, each Proposer that has not previously agreed to an extension of such deadline shall have the right to withdraw its Proposal. The Owner may, at its sole discretion, release any Proposal prior to that date.
- 28.02 Owner may, at its sole discretion release any Proposal and return the Proposal Security prior to the end of the time period stated immediately above.

ARTICLE 29: RESPONSIVENESS

- 29.01 To be deemed responsive, Proposals must be prepared thoroughly; be responsive to the requirements and criteria contained in the RFP; demonstrate an ability to meet the requirements of the RFP and conform to the material terms and/or conditions of the RFP, all as determined solely by the Owner. The Owner will reject a Proposal if it is incomplete, takes excessive exceptions to material terms and/or conditions of the RFP or defines plans for executing the Services and Work that do not appear to demonstrate an ability to meet the RFP requirements, all as determined solely by the Owner. The Owner will apply reasonable judgment, balance and discretion in deciding whether a Proposal is responsive.
- 29.02 Should the Owner's review of a Proposal result in the judgment by the Owner that the Proposal is not responsive, such Proposal will be returned to the Proposer submitting the Proposal along

with the Proposal security. A Proposer that submits a Proposal that is not responsive will not be considered for award of the Agreement.

ARTICLE 30: OWNER NOT RESPONSIBLE FOR ASSUMPTIONS BY PROPOSERS

30.01 Each Proposal shall present the assumptions that the Proposer has incorporated into its Proposal- Technical Proposal and Cost Proposal. Neither acceptance of the Proposal, nor participation of the Owner at any interviews with the Proposer, nor the subsequent award by the Owner of the Agreement, shall in any way be interpreted as an agreement or approval by the Owner that the assumptions are reasonable or correct or that the Owner accepts any liability for the assumptions. The Owner specifically disclaims responsibility or liability for any Proposer's assumptions in developing its Proposal.

ARTICLE 31: RIGHTS AND RESERVATIONS OF THE OWNER

31.01 In connection with this procurement process, including Proposals and award of the Agreement, Owner reserves to itself all rights (which rights shall be exercisable by Owner at its sole discretion) available to it under applicable law, including without limitation, the following with or without cause and with or without notice:

- A. The right to cancel, withdraw, postpone or extend RFP in whole or in part at any time prior to the execution by Owner of the Agreement without incurring any obligations or liabilities.
- B. The right to issue a new RFP or to revise and modify, at any time prior to the Proposal submittal date, information included in the RFP including but not limited to the dates set or projected and factors to be considered in evaluating Proposals and the responsibilities of the Proposers.
- C. The right to modify the procurement schedule.
- D. The right to waive minor and non-material deficiencies, informalities and irregularities in a Proposal and accept and review a non-conforming Proposal.
- E. The right to suspend and terminate the procurement process or to terminate evaluations of Proposals received at any time.
- F. The right to correspondence with the Proposers to seek an improved understanding of Proposals at any time.
- G. The right to seek or obtain data and information from any source that has the potential to improve the understanding and evaluation of the Proposals.
- H. The right to appoint and change appointees of any selection committee.
- I. The right to use assistance of outside technical and legal experts and consultants in the evaluation process.
- J. The right to respond to all, some or none of the inquiries, questions and/or requests for clarification received relative to this RFP.
- K. The right to seek clarifications from any Proposer to fully understand information provided in the Proposal.
- L. The right to request additional information from a Proposer during the evaluation of Proposals.

- M. The right to reject a Proposal containing exceptions, additions, qualifications or conditions not called for in the RFP.
- N. The right to conduct an independent investigation of any information, including prior experience identified in a Proposal by contacting project references, accessing public information, contacting independent parties or any other means.

ARTICLE 32: PARTNERING SESSION

- 32.01 The Owner may request that the selected Proposer include within its scope for Preconstruction Services a one day partnering session conducted by a third party facilitator. This session will create and foster a collaborative project environment committed to a team approach for a successful project. The selected Proposer should be prepared to submit a partnering session proposal to the owner which includes the session detailed agenda, resume of facilitator, references and a fee and expense statement. If the Owner decides to proceed with this session the scope of Preconstruction Services will be revised to include the scope and cost of such session to be conducted as soon as reasonably practical after Agreement execution.

ARTICLE 33: REQUIREMENTS TO KEEP PROPOSER AND CMAR TEAM INTACT AND KEY PERSONNEL.

- 33.01 The CMAR Team proposed by Proposer, including but not limited to the CMAR Team Members, Key Personnel and Alternate Key Personnel identified in the Statement of Qualifications and Proposal, shall remain for the duration of the procurement process and, if the Proposer is awarded the Agreement, the duration of the Project. If circumstances require a proposed change, it must be submitted in writing to the Point of Contact. During the procurement process the only circumstance that will allow for a proposed change will be that the Key Personnel or Alternate Key Personnel is longer under the employ of the Proposer or CMAR Team Member. The Owner, in its sole discretion, will determine whether to authorize the change. Unauthorized changes to the Proposer or Proposer's CMAR Team at any time during the procurement process may result in the elimination of the Proposer from further consideration.
- 33.02 The Proposer must provide the services of the proposed Key Personnel or Alternate Key Personnel for the preconstruction services phase. Due to the uncertainties of the timeframe for the initiation of construction due to the issuance of the Clean Water Act, Section 404 Permit from the U.S. Army Corps of Engineers, the Owner will require the following for the Key Personnel and Alternate Key Personnel for the procurement and construction services phases:
- A. CMAR will take reasonable efforts to provide these personnel as proposed when needed.
 - B. In the event these personnel cannot be provided, the CMAR will notify the District in writing requesting a substitute at least as qualified and experienced as the Key Personnel or Alternate Personnel proposed along with his/her resume.
 - C. The District will reserve the right to accept or reject the substitute as well as have the ability to interview the substitute

END OF SECTION

00 30 00 AVAILABLE BACKGROUND INFORMATION

ARTICLE 1: THE AVAILABLE BACKGROUND INFORMATION INCLUDES THE DOCUMENTS LISTED BELOW AND THEY CAN BE FOUND IN APPENDIX A INCLUDED AT THE END OF THIS RFP.

- A. Design Report for Lower Bois d' Arc Creek Reservoir Raw Water Pipeline (Project No. 317).
- B. Leonard WTP To McKinney No. 4 Treated Water Pipeline- Pipeline Corridor Selection Technical Memorandum.

00 42 23 PROPOSAL TRANSMITTAL FORM (PROPOSAL FORM 1)

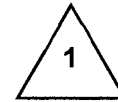

ARTICLE 1: PROPOSAL RECIPIENT AND PRINCIPAL CONTACT PERSON

- 1.01 This Proposal for Services for the Lower B' Arc Creek Reservoir Program - Raw Water Pipeline and Leonard Water Treatment Plant to McKinney No. 4 Treated Water Pipeline Project, North Texas Municipal Water District, Project No. 424 and Project No. 45 is submitted to:

President and Board of Directors
North Texas Municipal Water District
505 E. Brown Street, Wylie Texas 75098

- 1.02 The principal contact person who will serve as the interface between the Owner and the Proposer for all communications during the procurement period is:

Name: David Burkhart

Title: Regional Operations Manager
Address: 101 E FM 813, Palmer, TX 75152
Phone: (816) 853-1722
Fax: (816) 278-5965
Email: dburkhart@garney.com

ARTICLE 2: PROPOSER'S ACKNOWLEDGMENTS

- 2.01 The undersigned Proposer proposes and agrees, if this Proposal is accepted, to enter into a Construction Management At Risk Services Agreement with Owner in the form included in the RFP, to perform all Services and Work as specified or indicated in and within the amounts indicated in the Cost Proposal. Proposer agrees to complete the Services and Work within the Contract Price and within the Contract Time established in the Amendment(s) setting forth the Guaranteed Maximum Price and comply with the other terms and conditions of the Contract Documents.
- 2.02 Proposer accepts all of the requirements, terms, and conditions of the RFP, including without limitation those dealing with the Bid Bond, required performance and payment bonds and insurance. The Proposal will remain subject to acceptance for 90 days after the opening of Proposals.
- 2.03 Proposer accepts the provisions of the Construction Management At Risk Services Agreement as to Liquidated Damages in the event of its failure to complete Work in accordance with the schedule set forth in the Agreement.

ARTICLE 3: PROPOSER'S REPRESENTATIONS

3.01 In submitting this Proposal, Proposer certifies, represents and warrants, that:

- A. The submittal of the Proposal has been duly authorized by, and in all respects binding upon, the Proposer.
- B. The undersigned declares that it is the Proposer or by holding the position below indicated is authorized to execute this Proposal Transmittal Form on behalf of the Proposer and that all representations made on this form are true and accurate.
- C. Proposer has examined, carefully studied and understands and agrees to be bound by the requirements of the RFP, and Contract Documents, the other related data identified in the RFP, and the following Addenda, receipt of all of which is hereby acknowledged:

<u>Addendum No.</u>	<u>Addendum Date</u>	<u>Signature Acknowledging Receipt</u>
1	10/06/2016	<i>Matt Felt</i>
2	10/14/2016	<i>Matt Felt</i>
3	10/19/2016	<i>Matt Felt</i>
4	10/25/2016	<i>Matt Felt</i>

- D. Indicate below which statement is correct by putting an "x" in the appropriate space.
 - 1. All information and statements, including but not limited to the Financial Information and the Direct Financial Questions, contained in the Proposer's Statement of Qualifications (SOQ) submitted on July 29, 2015 remains true and accurate.
 - 2. Certain SOQ information is no longer true and accurate. The updated information that is true and accurate is more fully described on Proposal Form 2.
- E. All information and statements contained in the Proposal are current, correct and complete and are made with full knowledge that the Owner will rely on such information and statements in determining the selected Proposer for the Project.
- F. The submission of this Proposal will constitute an incontrovertible representation by Proposer that Proposer has complied with every requirement of the RFP that without exception the Proposal is premised upon completion of the Services required by the RFP, Addenda and the related supplemental data.
- G. Proposer acknowledges that it is aware and understands the requirements of Chapter 176 of the Texas Local Government Code and Proposer is solely responsible for complying with such requirements.
- H. If selected and not previously submitted, the Proposer will submit written evidence of its authority to do business in Texas not later than the date of its execution of the Agreement.
- I. Proposer has visited the Site and become familiar with and is satisfied as to the general, local and Site conditions that may affect cost, progress, and performance of the Work.

- J. Proposer is familiar with and is satisfied as to all federal, state and local Laws and Regulations that may affect cost, progress and the furnishing of the Work and Services.
- K. Proposer is aware of the general nature of work to be performed by Owner and others at the Site that relates to the Work as indicated in the Contract Documents.
- L. Proposer has correlated the information known to Proposer, information and observations obtained from visits to the Site, reports and drawings identified in the Contract Documents, and all additional examinations, investigations, explorations, tests, studies, and data with the Contract Documents.
- M. Proposer has given Point of Contact written notice of all conflicts, errors, ambiguities, or discrepancies that Proposer has discovered in the RFP and Contract Documents, and the written resolution thereof by Owner is acceptable to Proposer.
- N. The RFP and Contract Documents are generally sufficient to indicate and convey understanding of all terms and conditions for the performance of the Services and Work for which this Proposal is submitted.
- O. Proposer further represents that this Proposal is genuine and not made in the interest of or on behalf of any undisclosed individual or entity and is not submitted in conformity with any agreement or rules of any group, association, organization or corporation; Proposer has not directly or indirectly induced or solicited any other Proposer to submit a false or sham Proposal; Proposer has not solicited or induced any individual or entity to refrain from making a Proposal; and Proposer has not sought by collusion to obtain for itself any advantage over any other Proposer or over Owner.

ARTICLE 4: COST PROPOSAL FOR SERVICES

- 4.01 Proposer will provide CMAR Services in accordance with the RFP, Construction Management At Risk Services Agreement, the Standard General Conditions of the Construction Contract, Section 01 01 01 Construction Manager at Risk Services and Contract Documents for the prices shown in the Cost Proposal and will complete the construction of the Project within the Guaranteed Maximum Price established in a future Amendment(s).

ARTICLE 5: TIME OF COMPLETION

- 5.01 Proposer agrees that the Work will be substantially complete and will be completed and ready for final payment in accordance with Paragraph 14.07 of the Standard General Conditions of the Construction Contract on or before the dates or within the number of calendar days indicated in the Construction Management At Risk Services Agreement.

ARTICLE 6: THE PROPOSAL

- 6.01 The following documents are included as the Proposal and all attachments thereto are made a condition of the Proposal:
 - A. Technical Proposal meeting the requirements of 00 45 16
 - 1. Cover Letter.

2. Section 1: 00 42 23 Proposal Transmittal Form (Proposal Form 1) and attachments **including the Bid Bond and 00 42 23.02 (Proposal Form 2).**
 3. Section 2: Project Management and Execution Approach.
 4. Section 3: Preconstruction and Procurement Services Plan.
 5. Section 4: Construction Services Plan.
 6. Section 5: Quality Control Plan and Risk Management Plan.
- B. Cost Proposal
1. 00 42 23.01 Cost Proposal.
00 42 23.03 (Proposal Form 3) CMAR Services Man Hour Level of Effort.

ARTICLE 7: DEFINED TERMS

- 7.01 The terms used in this Proposal have the meanings indicated in the RFP, Construction Management At Risk Services Agreement, the Standard General Conditions of the Construction Contract and Section 01 01 01 Construction Manager at Risk Services. The significance of terms with initial capital letters is described in the RFP, Construction Management At Risk Services Agreement, the Standard General Conditions of the Construction Contract and Section 01 01 01 Construction Manager at Risk Services.

ARTICLE 8: VENUE

- 8.01 Proposer agrees that venue shall lie exclusively in Collin County, Texas for any legal action.

ARTICLE 9: PROPOSAL SUBMITTAL

9.01 This Proposal is submitted by:

If Proposer is an Individual:

Name: _____
(typed or printed)

By: _____
(Individual's Signature)

Doing business as: _____

Business address: _____

Phone: _____ E-mail: _____

Proposal submitted on the following date: _____

A Partnership

Partnership Name: _____
(typed or printed)

Name of General Partner: _____
(typed or printed)

By: _____
(Signature of general partner -- attach evidence of authority to sign)

Doing business as: _____

Business address: _____

Phone: _____ E-mail: _____

Proposal submitted on the following date: _____

A Corporation

Corporation Name: Garney Companies, Inc.
(typed or printed)

State of Incorporation: Missouri

Type: General Business
(General Business, Professional, Service, Limited Liability)

Date of Qualification to do business in Texas
is: May 9, 1977

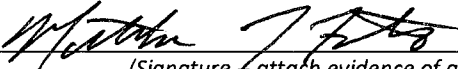
By: 
(Signature - attach evidence of authority to sign)

Name: Matthew T. Foster
(typed or printed)

Title: Vice President

Attest: 
(Signature of Corporate Secretary)

Business address: 1333 NW Vivion Road
Kansas City, MO 64118

Phone: (816) 746-7219 E-mail: mfoster@garney.com

Proposal submitted on the following date: October 28, 2016

Joint Venture

Joint Venturer Name: _____
(typed or printed)

By: _____
(Signature of joint venture partner -- attach evidence of authority to sign)

Name: _____
(typed or printed)

Title: _____

Business address: _____

Phone: _____ E-mail: _____

Proposal submitted on the following date: _____

Joint Venturer Name: _____
(typed or printed)

By: _____
(Signature of joint venture partner -- attach evidence of authority to sign)

Name: _____
(typed or printed)

Title: _____

Business address: _____

Phone: _____ E-mail: _____

Proposal submitted on the following date: _____

Contact for receipt of official communications:

Name: _____
(typed or printed)

Business address: _____

Phone: _____ E-mail: _____

Each joint venturer must sign. The manner of signing for each individual, partnership, and corporation that is a party to the joint venture should be in the manner indicated above.

Affidavits

One of the following four affidavits shall be executed and provided with this form.

AFFIDAVIT FOR CORPORATION

State MISSOURI) §
County of CLAY) §

Matthew T. Foster, being duly sworn deposes and says that they are Vice President of the
(Name) (Title)

Corporation submitting the foregoing form and related information; have read such documents; and that such documents are true and correct and contain no material misrepresentations; and that they are authorized to make this affidavit on behalf of the Corporation.

Matthew T. Foster
(Signature)

Signed and sworn to me before this 28th day of October, 20 16.

Whitney Briggs
(Notary Public)

My commission expires: 11/13/2017

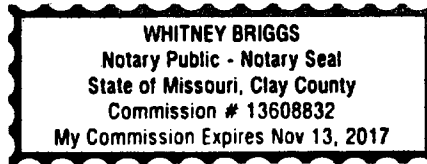

AFFIDAVIT FOR PARTNERSHIP

State _____) §

County of _____) §

_____, being duly sworn deposes and says
(Name)

that they are _____ of the
(Title)

_____ company submitting the foregoing form and related information; have read such documents; and that such documents are true and correct and contain no material misrepresentations; and that they are authorized to make this affidavit on behalf of the Partnership.

(Signature)

Signed and sworn to me before this _____ day of _____, 20__.

(Notary Public)

My commission expires:

AFFIDAVIT FOR INDIVIDUAL

State _____) §

County of _____) §

_____, being duly sworn deposes and says
(Name)

that they are _____ of the
(Title)

_____ company submitting the foregoing form and related information; have read such documents; and that such documents are true and correct and contain no material misrepresentations.

(Signature)

Signed and sworn to me before this _____ day of _____, 20__.

(Notary Public)

My commission expires:

JOINT VENTURE STATEMENT

We the undersigned do hereby give notice to our agreement to propose as a joint venture on the Project and by submitting the foregoing form and related information; have read such documents; and that such documents are true and correct and contain no material misrepresentations.

(Name of Joint Venture)

(Name of Firm)

(Signature)

Signed and sworn to me before this _____ day of _____, 20__.

(Notary Public)

My commission expires:

(Name of Firm)

(Signature)

Signed and sworn to me before this _____ day of _____, 20__.

(Notary Public)

My commission expires:

END OF SECTION



1333 NW Vivion Road, Kansas City, MO 64118
Phone: 816.741.4600
Fax: 816.741.4488
www.garney.com

December 23, 2016

North Texas Municipal Water District
501 E Brown St.
Wylie, TX 75098

Attn: Steve Long, PE
Reservoir Program Manager
Lower Bois d' Arc Creek Reservoir Program

Ref: Project Nos. 424 and 425
Lower Bois d'Arc Reservoir – Raw Water Pipeline and
Leonard Water Treatment Plant to McKinney No. 4 Treated Water Pipeline
Reduction in CMAR Preconstruction Services

Mr. Long-

Garney is pleased to provide the attached Revised Cost Proposal per your requested reduction in the duration of Preconstruction Services for the above reference project. The revisions to this cost proposal includes a reduced fee for Pre-construction Services in paragraph 2.01.A. This reduction is a result of the request by NTMWD for Garney to reduce or limit the CMAR services provided for the first three months of the project. It is our understanding that the Contract for CMAR Services on this project will be executed in January 2017 at which time CMAR Services will commence on a limited bases for three months and that beginning April 2017 the complete scope of CMAR services included in the Contract will be provided by Garney for the remainder of the phase duration.

Please let us know if any additional information is needed to allow the execution of the Agreement for this work to proceed.

Respectfully,

A handwritten signature in black ink, appearing to read "Matt Foster", written in a cursive style.

Matthew T. Foster
Vice President

Revision #1 - 2016.12.23
Reduction of Duration and Fees Section 2.01.A

00 42 23.01 COST PROPOSAL

ARTICLE 1: FEES FOR SERVICES FOR LOWER BOIS D'ARC CREEK RESERVOIR PROGRAM – RAW WATER PIPELINE AND LEONARD WATER TREATMENT PLANT TO MCKINNEY NO. 4 TREATED WATER PIPELINE PROJECT, NORTH TEXAS MUNICIPAL WATER DISTRICT PROJECT NO. 424 AND PROJECT NO. 425.

- 1.01 To: President and Board of Directors
North Texas Municipal Water District
505 E. Brown Street
Wylie, TX 75098
- 1.02 The undersigned Proposer proposes to furnish all services, materials and equipment required to perform the Construction Management at Risk Services (the "Services") described in Section 01 01 01 of the RFP for the prices indicated below.
- 1.03 The undersigned declares that it is the Proposer or by holding the position below indicated is authorized to execute this Cost Proposal on behalf of the Proposer and that all representations made on this Cost Proposal are true and correct.
- 1.04 The undersigned acknowledges that the Cost Proposal is based on the Construction Management At Risk Services Agreement and Standard General Conditions of the Construction Contract included in this RFP and as amended by any Addenda during the procurement period.
- 1.05 The undersigned acknowledges that the Cost Proposal is based on the information provided on 00 42 23.03 the CMAR Services Man Hour Level of Effort (Proposal Form 3) which is included with the Cost Proposal.

ARTICLE 2: FEES FOR WORK DESCRIBED IN SECTION 00 11 19 1.01 A.

- 2.01 Proposer will provide Construction Manager at Risk (CMAR) Services in accordance with the RFP, Construction Management At Risk Services Agreement, Standard General Conditions of the Construction Contract and Contract Documents for the prices shown below and will complete the construction of the Project within the Guaranteed Maximum Price established in a future Amendment.
 - A. Pre-construction Services Fee: The Lump Sum amount of \$ 1,565,000.00.
The lump sum amount stated above in Article 2.01(A) is the maximum amount to be paid to CMAR for the Pre-Construction Services and includes all costs and expenses in accordance with the Contract Documents for Pre-Construction Services as described in Section 01 01 01 "Construction Manager at Risk Services."
 - B. Procurement Service Fee: The Lump Sum amount of \$ 250,000.00.
The lump sum amount stated in Article 2.01(B) is the maximum amount to be paid to CMAR for Procurement Services and includes all costs and expenses in accordance with the Contract Documents for Procurement Services as described in Section 01 01 01 "Construction Manager at Risk Services."
 - C. Construction Services Fee (CMAR Fee): 2 percent of Cost of Work.

The percentage stated in Article 2.01(C) is the maximum amount to be paid to CMAR for the CMAR's construction services fee. CMAR's construction services fee is intended to compensate CMAR for its profit, as well as its indirect overhead costs not compensated through reimbursement for its General Conditions as defined in the Standard General Conditions of the Construction Contract and the Construction Management At Risk Services Agreement.

- 2.02 General Conditions (as defined in the RFP, the Standard General Conditions of the Construction Contract and the Construction Management At Risk Services Agreement and includes all costs and expenses in accordance with the Contract Documents for Construction Services as described in 01 01 01 "Construction Manager at Risk Services").

General Conditions: 5 percent of the sum of the subcontract costs, self-performed work, materials and equipment costs and special consultants' costs as defined in Article 11.01(A)(1)(a) and (b) of the Standard General Conditions of the Construction Contract.

The percentage stated in this section above is the flat-fee total amount of General Conditions to be included in the Guaranteed Maximum Price and to be paid to CMAR. In no event shall CMAR be paid more than the percentage described in this section for General Conditions.

- 2.03 Contingency Funds:

- A. Contingency Funds: 1 percent of Cost of Work.

The percentage stated in Article 2.03 (A) above is the maximum amount of Contingency Funds to be included in the Guaranteed Maximum Price and the maximum amount of Contingency Funds to be paid the CMAR.

Matthew T. Foster

Name

Vice President

Title

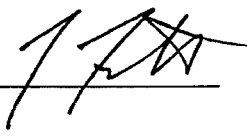
Signature

December 23, 2016

Date

**00 42 23.02 UPDATED SOQ INFORMATION AND 404 PERMIT DELAY COMMENTARY
(PROPOSAL FORM 2)**

ARTICLE 1: Proposer shall provide updated SOQ information below:

All personnel included in the Statement of Qualifications are included in this proposal and are serving in the same or very similar roles.

Garney has added CMAR Representatives to our organizational chart. We will assign two CMAR Representatives to the Raw Water Pipeline and one additional CMAR Representative to the Treated Water Pipeline. These individuals will support Walt Sinclair and Blake Rabel, Project Superintendents, as listed in the original Statement of Qualifications.

Andrew Beck, formerly listed in the Construction Phase as Treated Water Document Control and Quality Control Support is now serving as the Raw Water Quality Control. Daniel Murray, formerly listed as Raw Water Quality Control is now serving as Treated Water Document Control and Quality Control Support. Both individuals remain 100% committed to this project.

ARTICLE 2: 404 Permit Delay commentary:

Garney understands that NTMWD is currently pursuing the USACE 404 Permit for this project and is utilizing all means available to secure this permit in 2017. Garney also understands that the USACE 404 Permit for this project may not be acquired until April 2018 or later due to the complex nature of the permit acquisition process. We also understand that construction activities on this project are pending permit approval and may be delayed beyond the anticipated start dates of February 2019 and August 2019, respectively, and the sole source of remedy to the CMAR is an extension of the contract time.

The personnel and resources Garney has proposed for the Preconstruction and Procurement Services Phase of the LBCR Pipelines Project are committed to NTMWD for the prescribed duration of preconstruction and procurement services. If permit delays are experienced and NTMWD requires the suspension of CMAR services on this project, Garney will reallocate those resources to other ongoing projects Garney is completing for NTMWD. Keeping these personnel captive and dedicated to NTMWD will ensure Garney can respond immediately once CMAR services resume on the LBCR Pipelines Project.

00 43 43 WAGE RATES

1.0 GENERAL

1.01 PAYMENT OF PREVAILING WAGE RATES

- A. CMAR and any Subcontractor employed on this Project shall pay not less than the rates established by the Owner as required by Texas Government Code Chapter 2258.

1.02 RECORDS

- A. In accordance with Texas Government Code Chapter 2258.024, the CMAR and its Subcontractors, if any, shall keep a record showing:
 - 1. The name and occupation of each worker employed by the CMAR or Subcontractor in the construction of the Work; and
 - 2. The actual per diem wages paid to each worker.
- B. The record shall be open at all reasonable hours to inspection by the officers and agents of the Owner.

1.03 LIABILITY; PENALTY; CRIMINAL OFFENSE

- A. Texas Government Code Chapter 2258.003 – Liability: An officer, agent or employee of the Owner is not liable in a civil action for any act or omission implementing or enforcing Chapter 2258 unless the action was made in bad faith.
- B. Texas Government Code Chapter 2258.023(b) – Penalty: Any CMAR or Subcontractor who violates the requirements of Chapter 2258, shall pay to the Owner, on whose behalf the Agreement is made, \$60 for each worker employed or each calendar day or part of the day that the worker is paid less than the wage rates stipulated in the Agreement.
- C. Texas Government Code Chapter 2258.058- Criminal Offense:
 - 1. An officer, agent, or representative of the Owner commits an offense if the person willfully violates or does not comply with a provision of Chapter 2258.
 - 2. Any CMAR or Subcontractor, or an agent or representative of the CMAR or Subcontractor, commits an offense if the person violates Texas Government Code 2258.024.
 - 3. An offense is punishable by:
 - a. A fine not to exceed \$500;
 - b. Confinement in jail for a term not to exceed six months; or
 - c. Both a fine and confinement.

1.04 PREVAILING WAGE RATES

- A. The minimum rates for various labor classifications as established by the Owner are as shown in Appendix A.

APPENDIX A – PREVAILING WAGE RATES

Item	Worker	Minimum Prevailing Wage
1	Asbestos worker/ heat & frost insulator (includes application of all insulating materials, protective coverings, coatings and finishings to all types of mechanical systems)	\$12.13
2	Electrician – Cable splicer	\$22.67
3	Electrician	\$20.26
4	Line construction – Cable splicer	\$20.26
5	Line construction - Groundman	\$16.06
6	Line construction - Operators	\$18.80
7	Hydraulic crane – 35 ton and under	\$18.25
8	Hydraulic crane – over 35 tons, derricks, overhead gentry, stiffleg, tower, etc., and cranes with piledriving or caisson attachments	\$21.67
9	Iron workers - reinforcing and structural	\$14.76
10	Plumbers and Pipefitters	\$16.72
11	Sheet metal worker	\$17.38
12	Carpenter	\$10.54
13	Concrete Finisher	\$9.61
14	Form Builder	\$8.04
15	Form Setter	\$9.58
	Laborers	
16	Common	\$7.25
17	Utility	\$7.25
18	Pipelayer	\$7.97
	Power Equipment Operators	
19	Backhoe	\$10.98
20	Bulldozer	\$9.95
21	Front End Loader	\$10.78
22	Mechanic	\$9.88
23	Motor Grader	\$11.64
24	Oiler	\$9.19
25	Scraper	\$8.00
26	Truck Driver	\$7.47

The minimum prevailing wage rates indicated for Items 1 through 11 above are based upon survey data conducted and compiled by the North Texas Municipal Water District in August 2010. The minimum prevailing wage rates indicated for Items 12 through 26 above are based upon General Decision: TX20100036 05/04/2010 TX36 for Heavy Construction, Including Treatment Plants in Collin County

END OF SECTION

00 45 16 TECHNICAL PROPOSAL

ARTICLE 1: REQUIREMENTS FOR THE TECHNICAL PROPOSAL

- 1.01 The Technical Proposal must include, as a minimum, the information described in this Section. The information requested for the Technical Proposal is specific for the Project. The Owner is not interested in generic type information and narrative related to the submission requirement. Failure to submit the required information in the Technical Proposal may result in the Owner considering the Proposal as non-responsive and may result in rejection of the Proposal by the Owner. Proposers may be required to provide supplemental information to clarify, enhance or supplement the information provided in the Technical Proposals.
- 1.02 Proposers must provide the information requested in this Technical Proposal section. Information is requested, subject to the page limits indicated. The page limits do not include the Proposal Forms themselves. A copy of these forms will be provided in Microsoft Word to assist with the preparation of the Technical Proposals. Information in these forms must be provided completely and in detail. Failure to include the information completely and clearly may result in lower scores in the evaluations.

ARTICLE 2: TECHNICAL PROPOSALS SUBMISSION REQUIREMENTS AND PAGE LIMITS

- 2.01 Cover Letter –Subject to a maximum two (2) page limit, Proposers are free to submit a cover letter of their choice.
- 2.02 Section 00 42 23 Proposal Transmittal Form (Proposal Form 1) and all required attachments including the Bid Bond.
- 2.03 Project Management and Execution Approach
- A. Subject to a seven (7) page limit (excluding charts), describe how Proposer and CMAR Team and Key Personnel and other staff/positions will be organized and the respective roles **for this Project**. The organizational chart(s) should show Proposer's organizational and management structure that clearly identifies Proposer and CMAR Team Member's responsibility for the major functions to be performed for the Project for the Preconstruction and Construction Services phases including all the Project support functions (i.e. QA/QC, safety, project controls, etc.). The Proposer, CMAR Team, Key Personnel, other staff/positions shall be shown on an organization chart(s). Proposers shall provide the most experienced Key Personnel and other staff/positions. Proposers shall include similar type resumes as included in the Statement of Qualifications submission for any new Key Personnel or Alternative Key Personnel or other staff/positions identified on the organization chart(s). Charts shall indicate the anticipated and estimated percent of time of each Key Personnel, other staff identified by name that is not a Key Personnel, or position (without an individual's name) that will be committed to the Project.
- For purposes of the Proposal and the percent of time, Proposers will use a 24-month period for the preconstruction and procurement services and an 18-month construction services period for the Project. By way of example, if an individual will be involved in the

construction services 1 week per month (18 weeks), then the percent of time will be 4.5 (18 weeks) months divided by 18 months which yields 25%.

The charts shall include the critical support elements needed for a successful and safe Project that is on time and on budget.

The narrative must also include:

1. Description of how the organizational structure will facilitate managing the Services and Work required for this Project and allow for an efficient flow of information between the Proposer and the CMAR Team and its personnel and the Owner and its Program Manager, Engineers, Consultants, and other representatives.
2. Description of the roles, responsibilities, functional arrangements and reporting relationships between and among the Proposer, the CMAR Team Members, Key Personnel and other personnel on the organizational chart(s) that will be used for the Preconstruction and Construction Services of the Project.
3. Description of how the Proposer will interact with and involve the Owner and its Program Manager and Engineers in the Project and interact with the other CMARs for the Lower Bois d' Arc Creek Reservoir Program.
4. Description of how executive decisions will be made, communicated and implemented within the Proposer's overall Project organization and how issues will be identified and resolved prior to becoming a dispute.

2.04 **Project Plans:** For the Project plans required below, the Proposer shall provide specific information to provide the Owner with a clear understanding of the **Proposer's specific plan content and activities for this Project** and how it will be implemented during the Project. The Proposer can also discuss any unique or innovative features of any plan which it feels provides greater value and differentiates Proposer from other Proposers.

A. **Preconstruction and Procurement Services Plan**

1. Subject to a fifteen (15) page limit, Proposer shall describe its Preconstruction and Procurement Services Plan **for this Project** with emphasis on design reviews and constructability input, GMP process and scheduling. Proposers shall identify the critical constructability items of concern **for this Project** and why they are of concern. The Proposer will also discuss how these critical constructability items were addressed on prior projects the Proposer has been involved in.

B. **Construction Services Plan**

1. Subject to a ten (10) page limit, Proposer shall describe its Construction Plan **for this Project** with emphasis on project controls, site logistics, phasing, and communications and reporting.

C. **Quality Control Plan and Risk Management Plan**

1. Subject to a ten (10) page limit, Proposer shall describe its:
 - a). Quality Control Plan **for this Project** with emphasis on procedures and activities to minimize remedial work and maximize communication and coordination with

Engineer(s) and Owner. This narrative shall also include discussion on testing both raw water and treated water pipelines and treated water pipeline disinfection.

- b). Risk Management Plan **for this Project** with emphasis on how Project risks will be identified, evaluated, managed and tracked throughout the Project. Proposer will identify the most critical risks as it relates to schedule delays **for this Project** and how they would be mitigated. Proposer shall also describe if these risks were encountered in any previous projects of the Proposer and the results of the mitigation measures employed.

END OF SECTION

00 52 23 CONSTRUCTION MANAGEMENT AT RISK SERVICES AGREEMENT

THIS CONSTRUCTION MANAGEMENT AT RISK SERVICES AGREEMENT, hereinafter referred to as the "Agreement," is made and dated as of _____, 2017, between the North Texas Municipal Water District, a district created pursuant to Section 59, Article XVI of the Texas Constitution, acting by and through its duly authorized representative, having its principal offices at 505 E. Brown Street, Wylie, Texas 75098, hereinafter referred to as "Owner" or "NTMWD" and Garney Companies, Inc., a corporation, organized and operating under the laws of the State of Missouri, having an office at 1333 N.W. Vivion Road, Kansas City, Missouri 64118, hereinafter referred to as "CMAR," (each also hereinafter referred to as "Party" individually or "Parties" collectively), for construction management at risk services in connection with the Lower Bois d' Arc Creek Reservoir Program – Raw Water Pipeline and Treated Water Pipeline from the Leonard Water Treatment Plant to McKinney No. 4 Project.

Recitals

NTMWD is a regional water provider in the Dallas-Fort Worth Metroplex and provides treated water to approximately 1.6 million people. NTMWD is planning to construct a new reservoir, the Lower Bois d' Arc Creek Reservoir (LBCR), to address its current and future water supply needs. The proposed reservoir is in the permitting phase, and the actual construction start date is not known at this time. Construction of the dam may begin as soon as the permits are obtained. One of the accompanying projects associated with the Lower Bois d' Arc Creek Reservoir Program is the Raw Water Pipeline and Treated Water Pipeline from the Leonard Water Treatment Plant to McKinney No. 4 Project.

The raw water transmission line will be a 90 inch diameter pipe that extends approximately 40 miles from the raw water pump station to the terminal storage reservoir at the Leonard Water Treatment Plant site in Leonard, Texas. □

The treated water from Leonard WTP to No. 4 McKinney will be an 84 inch diameter pipe approximately 25 miles in length that extends from the Leonard Water Treatment Plant to the McKinney Number 4 delivery point in McKinney, Texas.

The Raw Water Pipeline and Treated Water Pipeline from the Leonard Water Treatment Plant to McKinney No. 4 Project will be completed using the construction manager-at-risk ("CMAR") project delivery method in accordance with Chapter 2269 of the Texas Government Code.

The NTMWD has determined to contract with a construction manager-at-risk to perform the preconstruction, procurement and construction services.

The NTMWD issued a Request for Qualifications (the "RFQ") on April 20, 2016.

Statements of Qualifications ("SOQs") submitted in response to the RFQ were received on May 27, 2016 from 3 proposers.

The SOQs were reviewed by the NTMWD and assigned a score based on the evaluation criteria and weighting set forth in the RFQ.

Based on the evaluations and scoring of the SOQs, the 2 highest ranked Proposers ("Short Listed Proposers") were short-listed to receive the Request for Proposals ("RFP").

Agreement

NTD14624 Lower Bois d' Arc Creek Reservoir Program –
Raw Water Pipeline and Treated Water Pipeline from the Leonard Water
Treatment Plant to McKinney No. 4 Project

00 52 23 - 1

The RFP was released to the Short Listed Proposers on September 7, 2016.

The proposals submitted in response to the RFP (“Proposals”) were received on October 28, 2016.

The Proposals were reviewed by the NTMWD and assigned a score based on the evaluation criteria and weighting set forth in the RFP.

Based on the evaluations and scoring of the Proposals, the highest ranked Proposer provided the best value Proposal for the performance of the services among the Short Listed Proposers responding to the RFP.

In December of 2016, the NTMWD initiated negotiations with CMAR for performance of the services, which have concluded with this Agreement.

On January 26, 2017, by Administrative Memorandum No. 4803, the governing body of the NTMWD authorized the execution and delivery of this Agreement on behalf of the NTMWD.

In consideration of the mutual covenants herein contained, the parties hereto, intending to be legally bound, agree as follows:

ARTICLE 1: REPRESENTATIONS AND WARRANTIES

1.01 Representations and Warranties of the CMAR.

A. The CMAR hereby represents and warrants that:

1. **Existence and Powers.** The CMAR is a corporation duly organized, validly existing and in good standing under the laws of the State of Missouri, with the full legal right, power and authority to enter into and perform its obligations under this Agreement.
2. **Due Authorization and Binding Obligation.** This Agreement has been duly authorized, executed and delivered by all necessary corporate action of the CMAR and constitutes the legal, valid and binding obligation of the CMAR, enforceable against the CMAR in accordance with the terms contained herein and pursuant to applicable law.
3. **Information Supplied by the CMAR.** The information supplied and representations and warranties made by the CMAR in all submittals made in response to the RFP with respect to the CMAR (and to the best of its knowledge after due inquiry, all information supplied in such submittals with respect to any CMAR Team Member) are true, correct and complete in all material respects.
4. **No Conflict of Interest.** The CMAR understands that as a political subdivision of Texas, the laws governing Owner’s Board, employees, and agents may prohibit certain persons from having a financial interest, directly or indirectly, in any contract with the Owner (“Prohibited Persons”). The CMAR represents and certifies that its owners, officers, employees and agents are not Prohibited Persons and that it has tendered to the Owner all necessary disclosures and other documents in compliance with the Owner’s policies and governing laws, including, without limitation, a discretionary contracts disclosure statement and a Conflict of Interest Questionnaire.

5. No Commitments Limiting Ability to Perform CMAR Services. The CMAR has no commitments, obligations, or impediments of any kind that would have a material and adverse impact on the ability of the CMAR to perform the Services in accordance with the Agreement. The CMAR covenants that it will not enter into any such commitment throughout the period of the performance of the Services.
6. No approvals required. No approval, authorization, order of consent or declaration of, or registration of filing with any governmental body is required for the valid execution and delivery of the Agreement by the CMAR except as such have been duly obtained or made.
7. Licensing and Registration Requirements. The CMAR possesses all licenses required under Laws and Regulations to perform all services required of the CMAR under this Agreement and is not in violation of any of the terms or conditions of such licenses. The CMAR is registered with all appropriate governmental bodies to the extent necessary to perform all of the Services. The CMAR has the authority to do business in the State of Texas.
8. No Litigation. Except as disclosed in writing to Owner, there is no legal proceeding, at law or in equity, before or by any court, arbitral tribunal or other governmental body pending or, to the best of the CMAR's knowledge after due inquiry, overtly threatened or publicly announced against the CMAR, in which an unfavorable decision, ruling or finding could reasonably be expected to have a material and adverse effect on the execution and delivery of this Agreement by the CMAR or the validity, legality or enforceability of this Agreement against the CMAR, or any other agreement or instrument entered into by the CMAR in connection with the transactions contemplated hereby, or on the ability of the CMAR to perform its obligations hereunder or under any such other agreements or instruments. For the purposes of this section only, "material" is defined to be an effect in excess of \$1M.
9. Claims and Demands. Except as disclosed in writing to Owner, there are no material and adverse claims or demands based in environmental, contract or tort law pending or threatened against the CMAR or any of its affiliates that would have a material and adverse effect upon the ability of the CMAR to perform the Services. For the purposes of this section only, "material" is defined to be an effect in excess of \$1M.
10. Laws and Regulations Compliance. Neither the CMAR nor any of its affiliates has any knowledge of any material violation of any law, order, rule or regulation with respect to any facilities or structures constructed by the CMAR or any of its affiliates. For the purposes of this section only, "material" is defined to be an effect in excess of \$1M.
11. The CMAR represents that it is familiar with the ethics requirements of the Owner and agrees to comply with such requirements.

ARTICLE 2: WORK, SERVICES AND THE PROJECT

- 2.01 CMAR shall complete all Work as specified or indicated in the Contract Documents. The "Work" is generally described as follows, and includes (but is not limited to) all Construction Management at Risk Services (the "Services") as specified or indicated in the Contract Documents Section 01 01 01, as well as the following:

Lower Bois d' Arc Reservoir Program - Raw Water Pipeline and Treated Water Pipeline from the Leonard Water Treatment Plant to McKinney No. 4 Project ("Project"), North Texas Municipal Water District Project No. 424 and Project No. 425. The Project consists of:

The raw water transmission line will be a 90 inch diameter pipe that extends approximately 40 miles from the raw water pump station to the terminal storage reservoir at the Leonard Water Treatment Plant site in Leonard, Texas. The treated water pipeline from Leonard WTP to No. 4 McKinney will be an 84 inch diameter pipe approximately 25 miles in length that extends from the Leonard Water Treatment Plant to the McKinney Number 4 delivery point in McKinney, Texas.

2.02 The Owner's Budget for the work immediately above is \$279.1 Million. Construction of the Raw Water Pipeline could be initiated as early as February 2019 with an anticipated completion to allow the water pipeline to be operational by August 2020. Construction of the Treated Water Pipeline from the Leonard Water Treatment Plant to McKinney No. 4 could be initiated as early as August 2019 with an anticipated completion to allow the pipeline to operational by February 2021.

2.03 This Project is commonly referred to as follows:

North Texas Municipal Water District
Lower Bois d' Arc Creek Reservoir Program - Raw Water Pipeline and Treated Water Pipeline from the Leonard Water Treatment Plant to McKinney No. 4 Project
North Texas MWD Project No. 424 and Project No. 425.

ARTICLE 3: ENGINEERS

3.01 Owner has retained the services of the following identified engineering firms to perform those professional services identified below.

3.02 Engineering design shall be performed by the following firms with regard to the general scopes of work as set forth below:

A. Raw Water Pipeline (separated into three segments)

1. Freese and Nichols, Inc.
2. Lockwood, Andres & Newnam, Inc.
3. Black & Veatch

B. Treated Water Pipeline (separated into two segments)

1. To be determined
2. To be determined

3.03 Collectively, the engineering firms are referred to as the "Engineers." The Engineer shall mean that engineering firm that has primary responsibility for the design and any construction

administration obligations over the respective scope of the Work. Each Engineer shall be legally responsible and liable for those consultants and subconsultants retained by the Engineer to provide the engineering services required in its agreement with the Owner.

- 3.04 Engineer, who is to act as Owner's representative, shall assume all duties and responsibilities, and have the rights and authority assigned to Engineer in the Contract Documents in connection with the completion of the Services and the Work in accordance with the Contract Documents.

ARTICLE 4: CONTRACT TIMES

- 4.01 Time of the Essence: All time limits for Milestones, if any, Substantial Completion, and completion and readiness for final payment as stated in the Contract Documents are of the essence of the Contract.

- 4.02 Dates for Substantial Completion and Final Payment:

The Work will be completed and ready for final payment in accordance with Paragraph 14.07 of the Standard General Conditions of the Construction Contract on or before the dates contemplated in Paragraph 2.02, above. These dates are approximate as of the time of this initial Agreement and will be fixed if and when a Guaranteed Maximum Price Amendment for the entire Work is established.

- 4.03 Liquidated Damages

CMAR and Owner recognize that time is of the essence in this Agreement and that Owner will suffer financial loss if the Work is not completed within the times specified in Paragraphs 2.01 and 2.02 above, plus any extensions of the Contract Times allowed in accordance with Article 12 of the Standard General Conditions of the Construction Contract. The parties also recognize the delays, expense, and difficulties involved in proving in a legal or arbitration proceeding the actual loss suffered by Owner if the Work is not completed on time. Accordingly, instead of requiring any such proof, Owner and CMAR agree that as liquidated damages for delay (but not as a penalty), CMAR shall pay Owner the amount of Liquidated Damages stipulated in the Amendment establishing the Guaranteed Maximum Price for each day that expires after the time specified in Paragraphs 2.01 and 2.02 for Substantial Completion until the Work is substantially complete. After Substantial Completion, if CMAR shall neglect, refuse, or fail to complete the remaining Work and achieve final completion within the Contract Time, CMAR shall pay Owner the amount of Liquidated Damages stipulated in the Amendment establishing the Guaranteed Maximum Price. The Owner will be the sole judge as to whether the Work has been completed within the allotted time. Assessment of Liquidated Damages by the Owner shall not constitute a waiver of the Owner's right to sue and collect additional damages which Owner may sustain by the failure of the CMAR to perform in accordance with the terms of its Contract.

ARTICLE 5: CONTRACT PRICE

- 5.01 Contract Price shall be as defined by Section 1.01 A (13) of the Standard General Conditions of the Construction Contract, which is incorporated herein by reference.

ARTICLE 6: CMAR'S CONSTRUCTION SERVICES FEE

- 6.01 CMAR's construction services fee ("CMAR Fee") shall be two percent (2%) of the Cost of the Work. CMAR Fee is intended to compensate CMAR for its profit, as well as its indirect overhead costs not compensated through reimbursement for its General Conditions, defined below and in the Standard General Conditions of the Construction Contract.
- 6.02 If Owner approves the use of contingency funds in accordance with Article 8 of this Agreement, CMAR shall be paid two percent (2%) of the contingency funds approved by Owner as its fee for construction services associated with the contingency work.

ARTICLE 7: COST OF THE WORK

- 7.01 Cost of the Work shall be defined by Section 11.01 of the Standard General Conditions of the Construction Contract, which is incorporated herein by reference.

ARTICLE 8: CONTINGENCY FUNDS

- 8.01 The contingency funds are for the exclusive use of the CMAR while executing the Work to reimburse the CMAR for Costs of Work due to unforeseen causes or details not capable of reasonable anticipation at the time of the execution of the Agreement; such contingency funds are not intended for changes in the scope of the Work or for reimbursement of expenses and costs not otherwise recoverable as a Cost of Work under Paragraph 11.01 of the Standard General Conditions of the Construction Contract. The contingency funds shall not be allocated to any particular line item in the Cost of Work.
- 8.02 The amount of the contingency funds shall be one percent (1%) of the Cost of Work.
- 8.03 Subject to prior written approval by the Owner, the contingency funds may be used for costs incurred in accordance with this Article by the CMAR. The CMAR shall prepare and submit to Owner a detailed listing and written justification as to the need to use any part of the contingency funds prior to using any part of the contingency funds. Charges against the contingency funds will be tabulated and reported by the CMAR as part of the CMAR's monthly Progress Meeting. CMAR will also provide a tracking system for the measurement and transfer of contingency accounts.
- 8.04 It is understood that the amount of any such contingency funds is the maximum amount available to the CMAR to cover costs incurred in accordance with this Article and that all cost overruns in excess of the contingency funds will be borne by the CMAR.

ARTICLE 9: GUARANTEED MAXIMUM PRICE

- 9.01 At the time specified in Section 9.02, below, the CMAR shall prepare a Guaranteed Maximum Price proposal (the "GMP Proposal") for the Owner's review and acceptance. The Guaranteed Maximum Price in the GMP Proposal shall be the sum of the CMAR's estimate of the Cost of Work, including contingencies described in Article 8, plus the CMAR Fee described in Article 6. If signed by the Owner, this total shall be established as the Guaranteed Maximum Price in an Amendment to the Agreement, and shall be subject to authorized increases or decreases for changes in the Work. By signing the Guaranteed Maximum Price Amendment, CMAR guarantees

that the total Contract Price will not exceed the GMP unless the Owner authorizes an increase in accordance with the Agreement. The CMAR is responsible for all costs in excess of the GMP, unless the GMP has been increased by Change Order for a change in scope of Work by the Owner.

9.02 Within 30 days after the CMAR is furnished the 90% Construction Documents and if the 404 Permit is not imminent, the CMAR shall provide the District a 90% GMP estimate. NTMWD will notify the CMAR in writing once the Section 404 permit is imminent, and assuming the 90% Construction Plans have already been provided to the CMAR, the CMAR shall have 30 days to submit its GMP Proposal for the entire Work, in such form and with such backup documentation as required herein for the GMP Proposal. Except as may otherwise be agreed by the Owner and the CMAR in advance, the GMP Proposal shall include a contingency fund of no more than is specified in Section 8.02, above.

9.03 Any GMP Proposal shall include the following, unless the Parties mutually agree otherwise:

- A. The proposed GMP will be developed as specified in Article 9 of this Agreement and as set out herein. The GMP Proposal shall be submitted in a binder with a title page that indicates whether the GMP Proposal is for an Early Work Package or GMP Proposal for the entire Work. If for an Early Work Package it shall be numbered and titled and dated. Binder pages shall be numbered. Binder shall include all specified items and components of a GMP as required by the Agreement. Sections must be divided by tabs for ease of reference. The GMP Proposal will be organized as follows:
1. Transmittal Letter
 2. Table of Contents
 3. Tab 1 – Executive Summary- brief general summary, including the Scope of Work for the GMP Proposal.
 4. Tab 2 – A list of Drawings and Specifications and other Contract Documents, with the most recent revisions dates, upon which the GMP Proposal is based.
 5. Tab 3 – Description of Variations, Substitutions proposed to the Drawings and Specifications.
 1. Specification listing- provide a detail listing of Specifications by division and section, which describes exclusions, substitutions, modifications, etc. If no changes are proposed for a particular section, insert “as per specifications.”
 - 1). Qualifications and Assumptions- a narrative summary of all qualifications and assumptions included in the Specifications listing.
 - 2). Exclusions- a summary of all exclusions included in the Specifications listing, plus any exclusions not related to the Specifications.
 2. A list of the assumptions and clarifications made by the CMAR in the preparation of the GMP Proposal, which list is intended to supplement the information regarding the scope and requirements of the Work contained in the Contract Documents.
 3. Value Analysis recommendations – if applicable.

4. Allowance Schedule – a list of allowances including definitions for all allowances or any open pricing terms and a statement of their basis – if applicable.
 5. A schedule of unit prices – if applicable.
 6. All other information used as the basis for the GMP Proposal.
6. Tab 4 – The proposed GMP for the designated portion of the Work -Cost of the Work Breakdown:
1. Estimated Cost of the Work shall be broken down into Master Format 2004 divisions and such additional sections and Early Work Packages as may have been directed by Owner prior to the submission of the GMP Proposal.
 2. Cost breakdown will be a lump sum for each Division and, if applicable, a section with information on proposed subcontractors and pricing supporting such costs.
 3. Itemized listing of all proposed General Conditions costs, including all definitions of cost categories.
 4. The GMP Proposal shall provide for contingency funds in accordance with the Agreement.
 5. Allowances and unit prices shall be included.
 6. It must include a description of how the estimated Cost of the Work was derived and prepared in accordance with the requirements of the Agreement.
7. Tab 5 Progress Schedule
1. The Progress Schedule for a GMP Proposal must include detailed activities for all events and Milestones included in the construction phase.
 2. Additionally, the Progress Schedule update must include detailed, logic driven activities for all construction phase activities.
 3. All paths in the Progress Schedule must lead to Milestone activities to ultimately achieve Substantial Completion on or before the Milestone for Substantial Completion.
 4. The Progress Schedule must be provided in hard copy form in the binder and also in an electronic format attached to the binder.
 5. A Schedule of Values based upon the Contract Time requirements.
- 9.04 Early Work Package shall be defined as a portion of Work that the Parties agree should be performed prior to the establishment of a Guaranteed Maximum Price for the Project. Prior to being provided with 90% Construction Drawings or establishment of a GMP Proposal for the entire Work, Early Work Packages may be awarded to the CMAR to facilitate the early preparation of the Site, purchase long lead time materials and equipment and otherwise accelerate certain portions of the Work in advance of an agreement between the Owner and CMAR regarding the GMP Amendment for the entire Work.
- 9.05 Either Owner or the CMAR may propose Early Work Packages to proceed prior to that time the GMP Proposal for the entire Work is approved by the Owner. Based upon the written agreement of the Parties, the CMAR may either self-perform, if selected by the Owner as the

successful Bidder, or subcontract such Early Work Packages before the GMP Proposal for the entire Work has been submitted and approved. The approved “not to exceed” amount for the scope of the Work included in any Early Work Package shall later be included within the GMP Proposal for the entire Work as an individual line item with reference made to the appropriate Early Work Package agreement. For any Early Work Package payments, the CMAR’s fee shall be the same percentage of the Cost of Work set forth in Section 6.01, above. Additionally, CMAR’s General Conditions costs relating to the Early Work Package shall be calculated in the same manner and in the same percentage stated in Article 2.02 of the Cost Proposal. The CMAR will be obligated to provide payment and performance bonds in accordance with Article 5 of the Standard General Conditions of the Construction Contract for the GMP amount of any Early Work Package.

- 9.06 The Owner may choose to accelerate the completion of certain portions of the design work so that some specific Early Work Packages may be awarded by the CMAR prior to the completion of the remaining Construction Documents or acceptance by the Owner of the GMP Proposal for the entire Work. The CMAR shall verify that the Engineer has provided the documents necessary to Bid and award any Early Work Package. Any Early Work Package shall contain language which makes those subcontracts 100% assignable to Owner at Owner’s option, in the event this Agreement is terminated, and that the Subcontractors shall be obligated to accept that assignment if it should occur.
- 9.07 After submission of any Early Work Package “not to exceed” proposal, as well as after submission of the GMP Proposal for the entire Work, the CMAR and Owner shall promptly meet to discuss and review the proposals.
- A. If Owner has any comments regarding the respective proposal or finds any inconsistencies or inaccuracies in the information presented, it shall promptly give written notice to the CMAR of such comments or findings.
 - B. To the extent that the estimated Cost of the Work of the GMP Proposal exceeds the Owner’s Budget, the CMAR shall exercise best efforts (as measured by its applicable standard of care under this Agreement) to propose Value Analysis solutions and other cost reduction measures to bring such construction costs within the Owner’s Budget.
 - 1. The Owner and CMAR may cooperate in the revision of the Scope of Work to reduce the cost and re-Bid those portions of the Scope of Work that were revised.
 - 2. The Owner may authorize the CMAR to re-bid some or all portions of the Scope of Work within a reasonable time in an attempt to reduce costs.
 - C. If appropriate, the CMAR shall, upon receipt of Owner’s notice to the CMAR, make appropriate adjustments to the GMP Proposal.
 - D. If Owner accepts a GMP Proposal, as may be amended by Owner and the CMAR, the GMP Proposal and its basis shall be set forth in a GMP Amendment to this Agreement.
 - E. Notice to Proceed on a GMP Amendment may be issued immediately upon full approval and execution and receipt of all required bonds and insurance.
 - F. The CMAR agrees that to the best of its knowledge that the Contract Documents at the time of the execution of the respective GMP Amendment are sufficient to enable it to determine the GMP for all the Work covered by such GMP Amendment and that such Work can be

completed in accordance with the Contract Documents for the GMP. By agreeing to a GMP, the CMAR agrees with the Owner that the Work required by the Contract Documents for the Work covered by the respective GMP Amendment, including without limitation, construction means, methods, procedures and techniques necessary to perform the Work, will be consistent with (i) good and sound practices within the construction industry, (ii) generally prevailing and accepted industry standards applicable to the Work, and (iii) requirements of any warranties applicable to the Work.

- 9.08 If Owner rejects the GMP Proposal for the entire Work (which it may do in its sole discretion) or fails to notify the CMAR in writing within thirty (30) calendar days of receipt of the GMP Proposal that it accepts the GMP Proposal, the GMP Proposal shall be deemed withdrawn and of no effect. In such event, Owner and the CMAR shall meet and confer as to how the Project will proceed with Owner having the following options, the selection of which option Owner may make in its sole discretion:
- A. Owner may suggest modifications to the GMP Proposal and consider the CMAR's additional Value Analysis proposals and other suggestions for cost reduction, whereupon, if such modifications are accepted in writing by the Owner and CMAR, the GMP Proposal shall be deemed accepted and the parties shall proceed in accordance with Section 9.07 D, E and F above; or
 - B. Owner may authorize and direct, in writing, the CMAR to proceed with the specified Work on the basis of reimbursement as provided in Article 6 (CMAR's Fee) and Article 7 (Cost of the Work) hereof without a GMP, in which case all references in Agreement to the GMP will not be applicable; or
 - C. Owner may terminate this Agreement in accordance with Article 19.

- 9.09 The intent of the Contract Documents is to include all items necessary for the proper execution and completion of the Work by the CMAR. The Contract Documents are complementary, and what is required by one shall be as binding as if required by all; performance by the CMAR shall be required only to the extent consistent with the Contract Documents and reasonably inferable from them being necessary to produce the indicated results. To the extent the Drawings and Specifications are anticipated to require further development by the Engineer, the CMAR has provided in the GMP for such further development consistent with the Contract Documents and reasonably inferable therefrom. Such further development does not include such things as changes in scope, systems, kinds and quality of materials, finishes or equipment, all of which, if required shall be incorporated by Change Order.

ARTICLE 10: CHANGES IN THE GUARANTEED MAXIMUM PRICE

- 10.01 The amount of any increases or decreases in the GMP that result from a change in the scope of Work shall be set forth in an applicable written Change Order. The amount of any such increase or decrease in the GMP shall be determined by Articles 11 and 12 of the Standard General Conditions of the Construction Contract.

ARTICLE 11: INTENTIONALLY DELETED

ARTICLE 12: PAYMENT PROCEDURES

12.01 Submittal and Processing of Payments for Services associated with the Pre-Construction Services and Procurement Services:

- A. On the first working day following the 25th of each month, Contractor shall submit to Owner for review an Application for Payment completed and signed by Contractor covering the Services completed as of the date of the Application and accompanied by such documentation as may be required.
- B. Engineer will within 10 days after receipt of each Application for Payment, either indicate in writing a recommendation of payment and present Application to Owner or return the Application to CMAR indicating in writing Engineer's reasons for refusing to recommend payment. In the latter case, Contractor may make the necessary corrections and resubmit the Application.
- C. Engineer's recommendation of any payment requested in an Application for Payment will constitute a representation by Engineer to Owner, based on Engineer's knowledge and review of the Services completed, that such Services were generally in accordance with the requirements of the Agreement and the Contract Documents.

Thirty days after presentation of the Application for Payment to Owner with Engineer's recommendation, the amount recommended will become due, and when due will be paid by Owner to CMAR.

12.02 Submittal and Processing of Payments for Services associated with the Construction Services: CMAR shall submit Applications for Payment of the Work in accordance with Article 14 of the Standard General Conditions of the Construction Contract. Applications for Payment will be processed by Engineer as provided in the Standard General Conditions of the Construction Contract.

12.03 Progress Payments and Retainage for the Work:

- A. Owner shall make progress payments on the basis of CMAR's Applications for Payment on or about the 25th day of each month during performance of the Work. All such payments will be measured by the Schedule of Values established as provided in Paragraph 2.07.A of the Standard General Conditions of the Construction Contract.
- B. Prior to Substantial Completion, progress payments will be made in an amount equal to 95 percent of the total amount earned for completed Work and properly stored materials on hand, with the balance being retainage withheld by Owner. Payment will be less the aggregate of payments previously made and less such amounts as Owner may be entitled to withhold pursuant to the Contract Documents, including but not limited to Liquidated Damages, in accordance with Paragraph 14.02 of the Standard General Conditions of the Construction Contract. In addition to the amount retained above, the Owner may retain additional amounts as permitted elsewhere in the Contract Documents.

12.03 Final Payment: Upon final completion and acceptance of the Work in accordance with Paragraph 14.07 of the Standard General Conditions of the Construction Contract, Owner shall pay within thirty (30) days the remainder of the Contract Price, as modified in accordance with the Contract Documents, and as recommended by Engineer as provided in said Paragraph 14.07.

In no event shall such final payment cause the total amount paid by Owner to exceed the Guaranteed Maximum Price.

ARTICLE 13: WORK SELF-PERFORMED BY CMAR OR A CMAR TEAM MEMBER

13.01 The CMAR may seek to perform portions of the Work itself, other than the work that may be included in the CMAR's General Conditions costs, if the CMAR submits its Bid and is awarded for those portions of the Work in the same manner as all other Subcontractors. If the CMAR intends to submit a Bid for such Work or a CMAR Team Member intends to submit a Bid, it shall notify Owner prior to soliciting Bids and all such Bids will be submitted directly to the Owner or the Engineer. If the Owner determines that the CMAR's Bid or CMAR Team Member's Bid provides the best value for Owner, the CMAR or CMAR Team Member will be awarded that portion of the Work. Owner's determination in such matters is final.

ARTICLE 14: INTEREST

14.01 The Owner is not obligated to pay interest on monies not paid except as provided in Section 2252.032 of the Texas Government Code.

ARTICLE 15: CMAR'S REPRESENTATIONS FOR THE WORK

15.01 CMAR makes the following representations:

- A. CMAR has examined and carefully studied the Contract Documents and the other related data identified in the Request for Proposals.
- B. CMAR has visited the Site and become familiar with and is satisfied as to the general, local, and Site conditions that may affect cost, progress, and performance of the Work.
- C. CMAR is familiar with and is satisfied as to all federal, state, and local Laws and Regulations that may affect cost, progress, and performance of the Work.
- D. CMAR has carefully studied: (1) reports of explorations and tests of subsurface conditions at or contiguous to the Site and all drawings of physical conditions in or relating to existing surface or subsurface structures at or contiguous to the Site including Underground Facilities which have been identified in the Supplementary Conditions as provided in Paragraph 4.02 of the Standard General Conditions of the Construction Contract and (2) reports and drawings of a Hazardous Environmental Condition, if any, at the Site which has been identified in the Supplementary Conditions as provided in Paragraph 4.06 of the Standard General Conditions of the Construction Contract.
- E. CMAR has obtained and carefully studied all additional or supplementary examinations, investigations, explorations, tests, studies, and data concerning conditions including surface, subsurface, and Underground Facilities at or contiguous to the Site which may affect cost, progress, or performance of the Work or which relate to any aspect of the means, methods, techniques, sequences, and procedures of construction to be employed by CMAR, including any specific means, methods, techniques, sequences, and procedures of construction expressly required by the Contract Documents, and safety precautions and programs incident thereto or assumes responsibility for doing so.

- F. CMAR does not consider that any further examinations, investigations, explorations, tests, studies, or data are necessary for the performance of the Work at the Contract Price, within the Contract Times, and in accordance with the other terms and conditions of the Contract Documents.
- G. CMAR is aware of the general nature of Work to be performed by Owner and others at the Site that relates to the Work as indicated in the Contract Documents.
- H. CMAR has correlated the information known to CMAR, information and observations obtained from visits to the Site, reports and drawings identified in the Contract Documents, and all additional examinations, investigations, explorations, tests, studies, and data with the Contract Documents.
- I. CMAR has given Engineer written notice of all conflicts, errors, ambiguities, or discrepancies that CMAR has discovered in the Contract Documents, and the written resolution thereof by Engineer is acceptable to CMAR.
- J. The Contract Documents are generally sufficient to indicate and convey understanding of all terms and conditions for performance and furnishing of the Work.

ARTICLE 16: ACCOUNTING RECORDS

16.01 Accounting Record Availability: CMAR shall keep such full and detailed accounts of materials incorporated and labor and equipment utilized for the Work consistent with the requirements of Paragraph 11.01.B of the Standard General Conditions of the Construction Contract and as may be necessary for proper financial management under this Agreement. Subject to prior written notice, Owner shall be afforded reasonable access during normal business hours to all CMAR's records, books, correspondence, instructions, drawings, receipts, vouchers, memoranda, and similar data relating to the Cost of the Work and CMAR's fee. CMAR shall preserve all such documents for a period of 5 years after the final payment by Owner.

ARTICLE 17: CONTRACT DOCUMENTS

17.01 Contents:

- A. The Contract Documents consist of the following:
 - 1. Specifications, all forms and documents listed in Section 00 01 10 "Table of Contents".
 - 2. Addenda (Numbers 00 91 00-1 to 00 91 00-4, inclusive).
 - 3. Exhibits to this Agreement (enumerated as follows):
 - 1. Treatment Plan for Inadvertent Discovery of Native American Human Remains or Unmarked Burials During Archaeological Investigations of the Area of Potential Effect (APE) for the Proposed Lower Bois d'Arc Reservoir an Agreement Between North Texas Municipal Water District, The U.S. Army Corps of Engineers, Tulsa District The Texas Historical Commission
 - 2. Treatment Plan An Agreement Between North Texas Municipal Water District the U.S. Army Corps of Engineers, Tulsa District The Texas Historical Commission and the Caddo Nation of Oklahoma

4. 00 42 23.01 Cost Proposal – Revision #1 – 2016.12.23
 5. This Agreement.
 6. Standard General Conditions of the Construction Contract.
- B. The following are also Contract Documents which may be delivered or issued on or after the Effective Date of the Agreement and are not attached hereto:
1. Notice to Proceed.
 2. Amendment(s).
 3. Change Order(s).
 4. Field Order(s).
 5. Work Change Directive(s).
 6. Engineers Written Interpretation(s).
- C. The documents listed in Paragraph 17.01.A are attached to this Agreement (except as expressly noted otherwise above).
- D. There are no Contract Documents other than those listed above in this Article 17.
- E. The Contract Documents may only be amended, modified, or supplemented as provided in Paragraph 3.04 of the Standard General Conditions of the Construction Contract.

ARTICLE 18: NON APPROPRIATION OF FUNDS

18.01 Notwithstanding any other provision of this Agreement, this Agreement may be terminated if for any reason there are not sufficient appropriated and available monies for the purpose of maintaining the District's payment obligations under this Agreement. In the event of such termination, the termination will be in accordance with Paragraph 15.03 of the Standard General Conditions of the Construction Contract.

ARTICLE 19: TERMINATION

19.01 In addition to the termination terms and conditions in Article 15 of the Standard General Conditions of the Construction Contract, CMAR's failure to provide the Key Personnel or Alternate Key Personnel will justify termination for cause by the Owner, unless such failure is due to death, disability or the personnel's voluntary separation from employment from the CMAR or its CMAR Team Members.

19.02 In addition to the termination terms and conditions in Article 15 of the Standard General Conditions of the Construction Contract, upon three days written notice, Owner may, without cause and without prejudice to any other right or remedy of Owner, terminate this Agreement at the conclusion of the Pre-Construction Services or failure of the Owner and CMAR to come to an agreement on the Guaranteed Maximum Price Proposal for the entire Work. The CMAR shall be paid for Services actually rendered through the date of termination.

ARTICLE 20: MISCELLANEOUS

- 20.01 Terms: Terms used in this Agreement will have the meanings stated in the Standard General Conditions of the Construction Contract and any Supplementary Conditions.
- 20.02 Assignment of Contract: No assignment by a party hereto of any rights under or interests in the Contract will be binding on another party hereto without the written consent of the party sought to be bound; and, specifically but without limitation, moneys that may become due and moneys that are due may not be assigned without such consent (except to the extent that the effect of this restriction may be limited by law), and unless specifically stated to the contrary in any written consent to an assignment, no assignment will release or discharge the assignor from any duty or responsibility under the Contract Documents.
- 20.03 Successors and Assigns: Owner and CMAR each binds itself, its partners, successors, assigns, and legal representatives to the other party hereto, its partners, successors, assigns, and legal representatives in respect to all covenants, agreements, and obligations contained in the Contract Documents.
- 20.04 Severability: Any provision or part of the Contract Documents held to be void or unenforceable under any Law or Regulation shall be deemed stricken, and all remaining provisions shall continue to be valid and binding upon Owner and CMAR, who agree that the Contract Documents shall be reformed to replace such stricken provision or part thereof with a valid and enforceable provision that comes as close as possible to expressing the intention of the stricken provision.
- 20.05 Venue: CMAR agrees that venue shall lie exclusively in district courts of Collin County, Texas for any legal action.
- 20.06 404 Permit: The initiation of construction is dependent upon Owner obtaining a 404 Permit. In the event that Owner has not obtained the 404 Permit and construction is otherwise ready to commence, the Services and Work contemplated under this Agreement shall be suspended until the 404 Permit is received, at no additional cost to the Owner. Owner shall notify CMAR in writing of any such suspension. CMAR hereby agrees that its sole remedy for any damages caused as a result of said delays in obtaining the 404 Permit is an extension of the Contract Time. CMAR hereby waives any remedy or claim it may have at law or in equity for an increase in the Contract Price as a result of any delays, disruptions of work, inefficiencies, schedule acceleration or compression, or similar damages related to the 404 Permit.

ARTICLE 21: INADVERTENT DISCOVERY OF NATIVE AMERICAN HUMAN REMAINS OR UNMARKED BURIALS

- 21.01 CMAR understands and acknowledges that Owner is bound by treatment plans for the inadvertent discovery of Native American human remains or unmarked burials (the "Treatment Plans"), which are attached as exhibits and incorporated by reference into this Agreement. Said Treatment Plans were made between Owner, the U.S. Army Corps of Engineers, Tulsa District, the Texas Historical Commission and the Caddo Nation of Oklahoma. CMAR understands and agrees to be bound by said Treatment Plans to the fullest extent allowed by law; CMAR and Owner reasonably anticipate that the progress of the Work will be encumbered at times by the need by CMAR and Owner to abide by the terms of the Treatment Plans, but that there shall be no change in the contract price, only the contract time (if necessary).

- 21.02 Pursuant to the Treatment Plans, all Work will be performed in a manner consistent with Title 13, Part II, Chapter 22, Cemeteries, and any other requirements under Chapter 711 of the Texas Health and Safety Code, and the Antiquities Code of Texas (Title 9, Chapter 191 of the Texas Natural Resources Code).
- 21.03 The term “human remains”, as defined under Chapter 711 of the Texas Health and Safety Code (711.001[15]), refers to the body of a decedent, and is inclusive of, born or ashes, and associated funerary objects; Chapter 711 of the Texas Health and Safety Code also defines “cemetery” as a place that is used or intended to be used for interment, and includes a graveyard, burial park, mausoleum, or any other area containing one or more graves (711.001[2]); the term “interment” means the permanent disposition of remains by entombment, burial, or placement in a niche (711.001[16]).
- 21.04 In the event that human remains are encountered during the performance of any Work, the CMAR shall immediately cease performance of Work and immediately notify Owner.
- A. CMAR shall notify Owner within one (1) hour of initially encountering human remains.
 - B. Notification by CMAR to Owner must be made by both telephone and email to the Designated Representative identified below.
- 21.05 In the event that unassociated artifacts are encountered during the performance of any Work, the CMAR shall immediately cease performance of Work and immediately notify Owner.
- A. CMAR shall notify Owner within one (1) hour of initially encountering unassociated artifacts.
 - B. Notification by CMAR to Owner must be made by both telephone and email to Mr. Steve Long, P.E.; 469-626-4173; slong@ntmwd.com.
- 21.06 NO DAMAGES FOR DELAY: CMAR understands that the discovery of potential human remains, unmarked burials, and/or historical artifacts will result in delays to the Work. CMAR hereby agrees that its sole remedy for any damages caused as a result of said delays is an extension of the contract time. CMAR hereby waives any remedy or claim it may have at law or in equity for an increase in the contract price as a result of any delays, disruptions of work, inefficiencies, schedule acceleration or compression, or similar damages related to the discovery of potential human remains, unmarked burials, and/or historical artifacts

IN WITNESS WHEREOF, Owner and CMAR have signed this Agreement in duplicate. One counterpart each has been delivered to Owner and CMAR. All portions of the Contract Documents have been signed or identified by Owner and CMAR or on their behalf.

This Agreement will be effective on _____.

Owner: North Texas Municipal Water District CMAR: Garney Companies, Inc.
(typed or printed) *(typed or printed)*

By: _____ By: _____
(Individual's signature) *(Individual's signature)*

Name: Terry Sam Anderson Name: Matthew T. Foster
(typed or printed) *(typed or printed)*

Title: President of the Board of Directors Title: Vice President
(typed or printed) *(typed or printed)*

Attest: _____ Attest: _____
John Sweeden, Secretary *(Individual's signature)*

Address for giving notice:

505 E. Brown Street
Wylie, Texas 75098

1333 N.W. Vivion Road
Kansas City, Missouri 64118

Designated representative:

Name: Thomas W. Kula
Title: Executive Director
Address: 505 E. Brown Street
Wylie, Texas 75098

Designated representative:

Name: Matthew T. Foster
Title: Vice President
Address: 1333 N. W. Vivion Road
Kansas City, Missouri 64118

Phone: 972-442-5405
Facsimile: 972-295-6440
E-mail: tkula@ntmwd.com

Phone: 816-746-7219
Facsimile: N/A
E-mail: mfoster@garney.com

(If CMAR is a corporation or a partnership, attach evidence of authority to sign.)

END OF SECTION

**TREATMENT PLAN FOR INADVERTENT DISCOVERY OF NATIVE
AMERICAN HUMAN REMAINS OR UNMARKED BURIALS DURING
ARCHAEOLOGICAL INVESTIGATIONS OF THE AREA OF POTENTIAL
EFFECT (APE) FOR THE PROPOSED LOWER BOIS D'ARC RESERVOIR
AN AGREEMENT BETWEEN
NORTH TEXAS MUNICIPAL WATER DISTRICT
THE U.S. ARMY CORPS OF ENGINEERS, TULSA DISTRICT
THE TEXAS HISTORICAL COMMISSION**

WHEREAS, the North Texas Municipal Water District (NTMWD) has proposed to construct the Lower Bois d'Arc Creek Reservoir (LBCR), which will be located on Bois d'Arc Creek near the City of Bonham in Fannin County, Texas; and

WHEREAS, NTMWD is a political subdivision of the State of Texas, and as such, is subject to compliance with the Antiquities Code of Texas (Title 9, Chapter 191 of the Texas Natural Resources Code); and

WHEREAS, the U.S. Army Corps of Engineers, Tulsa District (Tulsa District), has Federal responsibility and review authority to evaluate applications for permits issued under the national U.S. Army Corps of Engineers (USACE) regulatory program, pursuant to Section 404 of the Clean Water Act; and

WHEREAS, construction of the LBCR will require a permit in order to comply with Section 404 of the Clean Water Act; and

WHEREAS, issuing a permit pursuant to Section 404 of the Clean Water Act qualifies as an undertaking under Section 106 of the National Historic Preservation Act (NHPA) of 1966 (as amended); and

WHEREAS, Section 106 and its implementing regulation 36 CFR Part 800 require the Tulsa District to ensure that historic properties (as defined in 36 CFR 800.16 (l) (1) are identified and evaluated, and that adverse effects to those historic properties are assessed and resolved by avoiding, minimizing, or mitigating effects to historic properties prior to the issuance of a permit (the Section 106 Process); and

WHEREAS, the Area of Potential Effect (APE) for this project consists of the reservoir footprint itself to the elevation of the planned top of flood pool (elevation 541 ft. amsl at crest of emergency spillway), the planned location of the dam and all associated construction and staging areas, the planned new water treatment facility at Leonard, Texas, the pipeline from the new water treatment facility to the discharge point into Pilot Grove Creek (the pipeline from the new water treatment facility to the discharge point into Pilot Grove Creek was subsequently removed from the project after the execution of the Programmatic Agreement (PA) which established the

**TREATMENT PLAN
NATIVE AMERICAN HUMAN REMAINS OR UNMARKED BURIALS
PAGE 2**

APE, all raw water pipelines between the reservoir and associated existing water treatment facilities, lands manipulated for impact mitigation, plus the full horizontal and vertical extent of any identified cultural or historic resources intersected by or adjacent to any of the above listed project component boundaries and associated impact areas; and

WHEREAS, the effects of this undertaking on historic properties cannot be fully determined prior to approval of the undertaking; and

WHEREAS, Texas Historical Commission (THC) is the agency that administers the Antiquities Code of Texas (Title 9, Chapter 191, of the Texas Natural Resources Code) and has responsibilities under Chapter 711 of the Texas Health and Safety Code regarding the discovery and disposal of abandoned or unknown cemeteries; and

WHEREAS, the Executive Director of the THC serves as the State Historic Preservation Officer (SHPO) for Texas; and

WHEREAS, NTWD, Tulsa District, THC, and Caddo Nation of Oklahoma developed and executed a PA in accordance with 36 CFR 800.6 and 36 CFR 800.14(b)(3); and

WHEREAS, prior to contact with Europeans, the Lower Bois d'Arc Creek and Red River drainages in northeastern Texas were occupied by prehistoric populations not related to the Caddo Nation as well as historic populations that may retain historic properties and/or cemeteries of importance to those descendants; and

WHEREAS, the term human remains, as defined under Chapter 711 of the Texas Health and Safety Code (711.001 [15]), refers to the body of a decedent, and is inclusive of, bone or ashes, and associated funerary objects; Chapter 711 of the Texas Health and Safety Code also defines "cemetery" as a place that is used or intended to be used for interment, and includes a graveyard, burial park, mausoleum, or any other area containing one or more graves (711.001 [2]); the term "interment" means the permanent disposition of remains by entombment, burial, or placement in a niche (711.001 [16]); and

WHEREAS, human remains have been inadvertently discovered and thus a treatment plan for any future inadvertent discovery of human remains is necessary; and

WHEREAS, PARTIES agree this Treatment Plan will cover all NTMWD activities associated with the Proposed Lower Bois d'Arc Creek Reservoir Project (Project) from the date of the last signature below through completion of construction activities associated with the Project for the duration of the PA; and

WHEREAS, PARTIES agree that should human remains be discovered during the term of the PA and this Treatment Plan, whether through construction and construction related activities, wave action, or other forces, the guidance of the PA and the Treatment Plan should be followed; and

**TREATMENT PLAN
NATIVE AMERICAN HUMAN REMAINS OR UNMARKED BURIALS
PAGE 3**

WHEREAS, human remains as defined herein may be discovered during this Section 106 process, Section 106 does not govern treatment and disposition of human remains; and

WHEREAS, the project proponent (NTMWD) is a political entity of the State of Texas; and

WHEREAS, Tulsa District does not have sufficient legal interest in the land purchased by NTMWD according to the Native American Graves Protection and Repatriation Act (NAGPRA) (25 U.S.C. 3001 et seq.) Final Rule, and as determined by Tulsa District office of counsel; and

NOW, THEREFORE, any inadvertent discovery of human remains (as defined herein), will be addressed following the stipulations outlined in this Treatment Plan.

STIPULATIONS

The NTMWD shall ensure that the following measures will be carried out. All work conducted under this Treatment Plan will be performed in a manner consistent with the PA and with Title 13, Part II, Chapter 22, Cemeteries, and any other requirements under Chapter 711 Of The Texas Health and Safety Code, and The Antiquities Code of Texas (Title 9, Chapter 191 of The Texas Natural Resources Code).

I. TREATMENT OF HUMAN REMAINS

In the event that human remains are encountered during archaeological survey, shovel testing, unit excavating, land clearing, construction activity and/or shoreline erosion or any other unanticipated effects of the Project for the duration of this Plan, the following steps will be taken:

If human remains are represented by bone(s), a field determination of whether the bones are possibly human will be made. This may require additional exposure of bones sufficient to observe identifying characteristics. Since human remains are often not apparent or have deteriorated, a burial pit outline and/or a cluster of whole or broken pottery vessels, cremated human remains, or any other known indication of a burial will be treated as human remains.

1. Once the bones are determined likely to be human, or other evidence indicates the presence of prehistoric or historic human remains, excavation within the immediate vicinity of the discovery will cease, the associated sediments will be retained without screening and the remains will be documented via the following procedures:
 - a. Designation of the find as an archeological feature, logging and numbering the feature on the site feature list, completion of an archeological feature form, and mapping to an appropriate scale.

TREATMENT PLAN
NATIVE AMERICAN HUMAN REMAINS OR UNMARKED BURIALS
PAGE 4

- b. Measurement and recoding of the feature location (via a sufficient number of x, y, and z coordinates) relative to the site grid system.
 - c. Recording of burial in situ using archaeological best practices and the appropriate archaeological forms.
 - d. Exposed portions of human remains will be documented in situ and then associated sediments will be replaced and the excavation unit will be closed.
2. Reasonable measures to protect the site from further disturbance or vandalism will be put into place. No identifying markers will be left at the burial site.
3. Local law enforcement officials will be notified immediately of the discovery of human remains either by telephone or personal communication. The Medical Examiner (ME) should then be contacted in order to make a determination regarding the age of the remains. Upon official determination by law enforcement (the ME) that the remains are of such age to rule out association with a crime or other recent event, the designation will be changed from an archeological feature to human remains and Notice of Existence of Cemetery form will be filed with the county.
4. Within forty-eight (48) hours of the discovery of human remains, NTMWD shall initiate consultation with the Tulsa District, Caddo Nation THPO, and THC SHPO by telephone or email.
5. Through consultation with tribes with a documented interest in the area, an attempt will be made to identify the cultural affiliation of the human remains. It is likely that any remains found will be identified as Caddo due to the proximity of the many documented Caddo culturally affiliated sites within the Project area. However, if it is determined the remains are not Caddo culturally affiliated, NTMWD will consult with USACE and THC on further actions and consultation requirements.
6. Control and disposition of the remains will be determined in consultation with any interested tribes and the PARTIES.
7. If human remains as defined herein are discovered in the archaeological lab, no intrusive or destructive analysis will be conducted on human remains without the documented approval of the affiliated tribe (if known) and the PARTIES. Approval may be given by email.
8. Should number 7 apply, upon completion of non-destructive analyses/documentation of the human remains, if affiliation continues to be undetermined, and no claims are made for the remains, then, with agreement of the PARTIES, the remains will be reinterred within the shovel test and/or unit excavation from which they were excavated or in an area as close as possible to that location if soil has been moved, provided such reburial is

TREATMENT PLAN
NATIVE AMERICAN HUMAN REMAINS OR UNMARKED BURIALS
PAGE 5

consistent with the project footprint. No identifying markers will be left at the burial site. If the remains cannot be reburied in a manner consistent with the project footprint, NTMWD will consult with the PARTIES on ways to mitigate these adverse effects. If cultural affiliation is made possible as a result of the nondestructive analyses, the affiliated tribe or tribes will be notified and disposition of the remains will be determined in consultation with the tribe(s) and the PARTIES.

9. Future avoidance of human remains/burial sites is the preferred option; however, where avoidance of human remains/burial sites is not feasible, the stipulations in this treatment plan will be followed.
10. NTMWD will turn over any unassociated artifacts collected and records to the Texas Archaeological Research Laboratory at the University of Texas in Austin after analysis is complete and a final report prepared and approved by the PARTIES.

TREATMENT PLAN
NATIVE AMERICAN HUMAN REMAINS OR UNMARKED BURIALS
PAGE 6

Darwin Whiteside

Darwin Whiteside, President, Board of Directors
North Texas Municipal Water District

01/25/2014

Date

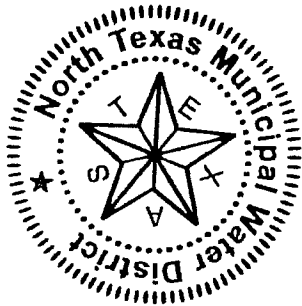

**TREATMENT PLAN
NATIVE AMERICAN HUMAN REMAINS OR UNMARKED BURIALS
PAGE 7**



Authorizing Officer
Caddo Nation of Oklahoma

12-11-14

Date

**TREATMENT PLAN
NATIVE AMERICAN HUMAN REMAINS OR UNMARKED BURIALS
PAGE 8**

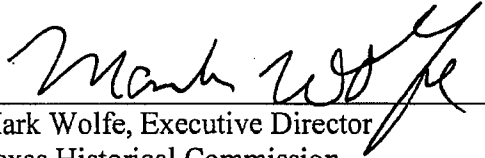

Mark Wolfe, Executive Director
Texas Historical Commission

9/25/14
Date

**TREATMENT PLAN
NATIVE AMERICAN HUMAN REMAINS OR UNMARKED BURIALS
PAGE 9**



Richard A. Pratt, Colonel, U.S. Army
District Commander U.S. Army Corps of Engineers, Tulsa District

26 Sept 14

Date

**TREATMENT PLAN
AN AGREEMENT BETWEEN
NORTH TEXAS MUNICIPAL WATER DISTRICT
THE U.S. ARMY CORPS OF ENGINEERS, TULSA DISTRICT
THE TEXAS HISTORICAL COMMISSION AND
THE CADDO NATION OF OKLAHOMA**

WHEREAS, the North Texas Municipal Water District (NTMWD) has proposed to construct the Lower Bois d'Arc Creek Reservoir (LBCR), which will be located on Bois d'Arc Creek near the City of Bonham in Fannin County, Texas; and

WHEREAS, NTMWD is a political subdivision of the State of Texas, and as such, is subject to compliance with the Antiquities Code of Texas (Title 9, Chapter 191 of the Texas Natural Resources Code); and

WHEREAS, the U.S. Army Corps of Engineers, Tulsa District (Tulsa District), has Federal responsibility and review authority to evaluate applications for permits issued under the national U.S. Army Corps of Engineers (USACE) regulatory program, pursuant to Section 404 of the Clean Water Act; and

WHEREAS, construction of the LBCR will require a permit in order to comply with Section 404 of the Clean Water Act; and

WHEREAS, issuing a permit pursuant to Section 404 of the Clean Water Act qualifies as an undertaking under Section 106 of the National Historic Preservation Act (NHPA) of 1966 (as amended); and

WHEREAS, Section 106 and its implementing regulation 36 CFR Part 800 require the Tulsa District to ensure that historic properties (as defined in 36 CFR 800.16 (l) (1) are identified and evaluated, and that adverse effects to those historic properties are assessed and resolved by avoiding, minimizing, or mitigating effects to historic properties prior to the issuance of a permit (the Section 106 Process); and

WHEREAS, the Area of Potential Effect (APE) for this project consists of the reservoir footprint itself to the elevation of the planned top of flood pool (elevation 541 ft. amsl at crest of emergency spillway), the planned location of the dam and all associated construction and staging areas, the planned new water treatment facility at Leonard, Texas, the pipeline from the new water treatment facility to the discharge point into Pilot Grove Creek (the pipeline from the new water treatment facility to the discharge point into Pilot Grove Creek was subsequently removed from the project after the execution of the Programmatic Agreement (PA) which established the APE, all raw water pipelines between the reservoir and associated existing water treatment facilities, lands manipulated for impact mitigation, plus the full horizontal and vertical extent of

**TREATMENT PLAN
CADDO CULTURALLY AFFILIATED HUMAN REMAINS
PAGE 2**

any identified cultural or historic resources intersected by or adjacent to any of the above listed project component boundaries and associated impact areas; and

WHEREAS, the effects of this undertaking on historic properties cannot be fully determined prior to approval of the undertaking; and

WHEREAS, Texas Historical Commission (THC) is the agency that administers the Antiquities Code of Texas (Title 9, Chapter 191, of the Texas Natural Resources Code) and has responsibilities under Chapter 711 of the Texas Health and Safety Code regarding the discovery and disposal of abandoned or unknown cemeteries; and

WHEREAS, the Executive Director of the THC serves as the State Historic Preservation Officer (SHPO) for Texas; and

WHEREAS, Mr. Robert Cast serves as the Tribal Historic Preservation Officer (THPO) for the Caddo Nation of Oklahoma (Caddo Nation); and

WHEREAS, NTWD, Tulsa District, THC, and Caddo Nation of Oklahoma (PARTIES) developed and executed a PA in accordance with 36 CFR 800.6 and 36 CFR 800.14(b)(3); and

WHEREAS, prior to contact with Europeans, the Lower Bois d'Arc Creek and Red River drainages in northeastern Texas were occupied by ancestors of the Caddo Nation and thus may retain historic properties of traditional religious and cultural importance to the Caddo Nation; and

WHEREAS, PARTIES acknowledge that the Caddo Nation's highest priority is to avoid disturbing Caddo culturally affiliated human remains through consultation and appropriate avoidance and mitigation measures; and

WHEREAS, the term human remains, as defined under Chapter 711 of the Texas Health and Safety Code (711.001 [15]), refers to the body of a decedent, and is inclusive of, bone or ashes, and associated funerary objects; Chapter 711 of the Texas Health and Safety Code also defines "cemetery" as a place that is used or intended to be used for interment, and includes a graveyard, burial park, mausoleum, or any other area containing one or more graves (711.001 [2]); the term "interment" means the permanent disposition of remains by entombment, burial, or placement in a niche (711.001 [16]); and

WHEREAS, Caddo culturally affiliated human remains have been inadvertently discovered and thus a treatment plan for those remains and any future inadvertent discovery of Caddo culturally affiliated human remains and funerary objects is necessary; and

WHEREAS, PARTIES agree that any inadvertently discovered Caddo culturally affiliated human remains and their associated funerary objects shall be reinterred within the shovel test and/or unit excavation from which they were excavated or in an area as close as possible to that

**TREATMENT PLAN
CADDO CULTURALLY AFFILIATED HUMAN REMAINS
PAGE 3**

location if soil has been moved, provided such reburial is consistent with the project footprint. If it is determined the Caddo culturally affiliated remains cannot be reburied in a manner consistent with the project footprint, PARTIES will consult on ways to mitigate these adverse effects; and

WHEREAS, PARTIES agree this Treatment Plan will cover all NTMWD activities associated with the Proposed Lower Bois d' Arc Creek Reservoir Project (Project) from the date of the last signature below through completion of construction activities associated with the Project and for the duration of the PA; and

WHEREAS, PARTIES agree that should human remains be discovered during the term of the PA and this Treatment Plan, whether through construction and construction related activities, wave action, or other forces, the guidance of the PA and the Treatment Plan should be followed; and

WHEREAS, human remains as defined herein may be discovered during this Section 106 process, Section 106 does not govern treatment and disposition of human remains; and

WHEREAS, the project proponent (NTMWD) is a political entity of the State of Texas; and

WHEREAS, Tulsa District does not have sufficient legal interest in the land purchased by NTMWD according to the Native American Graves Protection and Repatriation Act (NAGPRA) (25 U.S.C. 3001 et seq.) Final Rule, and as determined by Tulsa District office of counsel; and

NOW, THEREFORE, any inadvertent discovery of human remains (as defined herein), will be addressed following the stipulations outlined in this Treatment Plan.

STIPULATIONS

The NTMWD shall ensure that the following measures will be carried out. All work conducted under this Treatment Plan will be performed in a manner consistent with the PA and with Title 13, Part II, Chapter 22, Cemeteries, and any other requirements under Chapter 711 Of The Texas Health and Safety Code, and The Antiquities Code of Texas (Title 9, Chapter 191 of The Texas Natural Resources Code).

I. TREATMENT OF CADDO CULTURALLY AFFILIATED HUMAN REMAINS

In the event that human remains are encountered during archaeological survey, shovel testing, unit excavating, land clearing, construction activity and/or shoreline erosion, or any other unanticipated effects of the Project for the duration of this Plan, and the human remains are determined to be affiliated with the Caddo Nation, the following steps will be taken:

1. A field determination of whether the bones are possibly human will be made. This may require additional exposure of bones sufficient to observe identifying characteristics. Since human remains are often not apparent or have deteriorated, a burial pit outline and/or a cluster of whole or broken pottery vessels will be treated as human remains.

TREATMENT PLAN
CADDO CULTURALLY AFFILIATED HUMAN REMAINS
PAGE 4

2. Once the bones have been determined to be culturally affiliated to the Caddo, excavation within the immediate vicinity of the discovery will cease, the associated sediments will be retained without screening and the remains will be documented via the following procedures:
 - a. Designation of the find as an archeological feature, logging and numbering the feature on the site feature list, completion of an archeological feature form, and mapping to an appropriate scale.
 - b. Measurement and recoding of the feature location (via a sufficient number of x, y, and z coordinates) relative to the site grid system.
 - c. Photographing the feature in situ and logging the photos in the site photo records.
 - d. Exposed portions of Caddo culturally affiliated human remains or archaeological features will be documented in situ and then associated sediments will be replaced and the excavation unit will be closed.
3. Reasonable measures to protect the site from further disturbance or vandalism will be put into place. Knowledge of the site would be limited to only those individuals who have a need to know about the site. A decision would be made in the field by the Principal Investigator considering the location, appearance and general accessibility of the site on any additional protective measures that might also be necessary. No identifying markers will be left at the burial site.
4. Local law enforcement officials will be notified immediately of the discovery of human remains either by telephone or personal communication. The Medical Examiner (ME) should be contacted to make the determination regarding the age of the human remains. Upon official determination by law enforcement (the ME) that the remains are of such age to rule out association with a crime or other recent event, the designation will be changed from an archeological feature to human remains and Notice of Existence of Cemetery form will be filed with the county.
5. Within forty-eight (48) hours of the discovery of Caddo culturally affiliated human remains, NTMWD shall initiate consultation with the Tulsa District, Caddo Nation THPO, and THC SHPO by telephone or email.
6. If human remains as defined herein are discovered in the archaeological lab, no intrusive or destructive analysis will be conducted on human remains without the documented approval of the affiliated tribe (if known) and the PARTIES. Approval may be given by email.
7. Should number 6 apply, all Caddo culturally affiliated human remains will be housed during analysis and/or until reinterment in a continually lighted area of a secure facility.

TREATMENT PLAN
CADDO CULTURALLY AFFILIATED HUMAN REMAINS
PAGE 5

8. No intrusive or destructive analysis will be conducted on Caddo culturally affiliated human remains or funerary objects.
9. Future avoidance of Caddo culturally affiliated human remains/burial sites is the preferred option; however, where avoidance of human remains/burial sites is not feasible, the stipulations in this treatment plan will be followed.
10. An electronic copy of a final report, plus any photographs, notes, or documents associated with an inadvertent discovery will be provided to Caddo Nation Cultural Preservation Department upon completion of the project following the review process as defined in the PA.
11. NTMWD will turn over any unassociated artifacts collected and records to the Texas Archaeological Research Laboratory at the University of Texas in Austin after analysis is complete and a final report prepared and approved by the PARTIES.

**TREATMENT PLAN
CADDO CULTURALLY AFFILIATED HUMAN REMAINS
PAGE 6**

Darwin Whiteside

Darwin Whiteside, President, Board of Directors
North Texas Municipal Water District

09/25/2014

Date

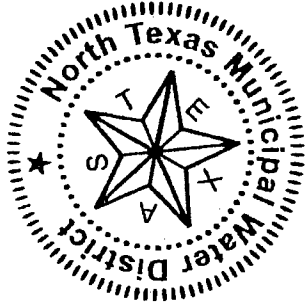

**TREATMENT PLAN
CADDO CULTURALLY AFFILIATED HUMAN REMAINS
PAGE 7**



Authorizing Officer
Caddo Nation of Oklahoma

12.11.14
Date

TREATMENT PLAN
CADDO CULTURALLY AFFILIATED HUMAN REMAINS
PAGE 8

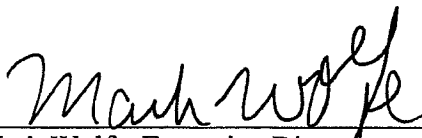

Mark Wolfe, Executive Director
Texas Historical Commission

9/25/14

Date

**TREATMENT PLAN
CADDO CULTURALLY AFFILIATED HUMAN REMAINS
PAGE 9**



Richard A. Pratt, Colonel, U.S. Army
District Commander U.S. Army Corps of Engineers, Tulsa District

26 Sep 14
Date

This document has important legal consequences; consultation with an attorney is encouraged with respect to its use or modification. This document should be adapted to the particular circumstances of the contemplated Project and the controlling Laws and Regulations.



STANDARD GENERAL CONDITIONS OF THE CONSTRUCTION CONTRACT

Prepared by

ENGINEERS JOINT CONTRACT DOCUMENTS COMMITTEE

and

Issued and Published Jointly by



AMERICAN COUNCIL OF ENGINEERING COMPANIES

ASSOCIATED GENERAL CONTRACTORS OF AMERICA

AMERICAN SOCIETY OF CIVIL ENGINEERS

PROFESSIONAL ENGINEERS IN PRIVATE PRACTICE
A Practice Division of the
NATIONAL SOCIETY OF PROFESSIONAL ENGINEERS

Endorsed by



CONSTRUCTION SPECIFICATIONS INSTITUTE

These General Conditions have been prepared for use with the Suggested Forms of Agreement Between Owner and Contractor (EJCDC C-520 or C-525, 2007 Editions). Their provisions are interrelated and a change in one may necessitate a change in the other. Comments concerning their usage are contained in the Narrative Guide to the EJCDC Construction Documents (EJCDC C-001, 2007 Edition). For guidance in the preparation of Supplementary Conditions, see Guide to the Preparation of Supplementary Conditions (EJCDC C-800, 2007 Edition).

Copyright © 2007 National Society of Professional Engineers
1420 King Street, Alexandria, VA 22314-2794
(703) 684-2882
www.nspe.org

American Council of Engineering Companies
1015 15th Street N.W., Washington, DC 20005
(202) 347-7474
www.acec.org

American Society of Civil Engineers
1801 Alexander Bell Drive, Reston, VA 20191-4400
(800) 548-2723
www.asce.org

Associated General Contractors of America
2300 Wilson Boulevard, Suite 400, Arlington, VA 22201-3308
(703) 548-3118
www.agc.org

The copyright for this EJCDC document is owned jointly by the four EJCDC sponsoring organizations and held in trust for their benefit by NSPE.

STANDARD GENERAL CONDITIONS OF THE CONSTRUCTION CONTRACT

TABLE OF CONTENTS

	Page
Article 1 – Definitions and Terminology	1
1.01 Defined Terms.....	1
1.02 Terminology.....	6
Article 2 – Preliminary Matters.....	7
2.01 Delivery of Bonds and Evidence of Insurance.....	7
2.02 Copies of Documents.....	7
2.03 Commencement of Contract Times; Notice to Proceed	8
2.04 Starting the Work.....	8
2.05 Before Starting Construction.....	8
2.06 Preconstruction Conference; Designation of Authorized Representatives	8
2.07 Initial Acceptance of Schedules	9
Article 3 – Contract Documents: Intent, Amending, Reuse.....	9
3.01 Intent.....	9
3.02 Reference Standards	10
3.03 Reporting and Resolving Discrepancies	11
3.04 Amending and Supplementing Contract Documents	12
3.05 Reuse of Documents	12
3.06 Electronic Data.....	13
Article 4 – Availability of Lands; Subsurface and Physical Conditions; Hazardous Environmental Conditions; Reference Points	13
4.01 Availability of Lands	13
4.02 Subsurface and Physical Conditions	14
4.03 Differing Subsurface or Physical Conditions.....	14
4.04 Underground Facilities	15
4.05 Reference Points	16
4.06 Hazardous Environmental Condition at Site.....	17
Article 5 – Bonds and Insurance	19
5.01 Performance, Payment, and Other Bonds	19
5.02 Licensed Sureties and Insurers	20
5.03 Certificates of Insurance	20
5.04 Contractor’s Insurance.....	21
5.05 Owner’s Liability Insurance	24
5.06 Property Insurance	24
5.07 Waiver of Rights	26
5.08 Receipt and Application of Insurance Proceeds	27
5.09 Acceptance of Bonds and Insurance; Option to Replace.....	27

5.10	Partial Utilization, Acknowledgment of Property Insurer	27
5.11	Owner's Insurance for Project.....	27
<hr/>		
Article 6 – Contractor’s Responsibilities		28
6.01	Supervision and Superintendence	28
6.02	Labor; Working Hours.....	28
6.03	Services, Materials, and Equipment	29
6.04	Progress Schedule	29
6.05	Substitutes and “Or-Equals”	29
6.06	Concerning Subcontractors, Suppliers, and Others	32
6.07	Patent Fees and Royalties	33
6.08	Permits.....	34
6.09	Laws and Regulations.....	34
6.10	Taxes	37
6.11	Use of Site and Other Areas	37
6.12	Record Documents.....	38
6.13	Safety and Protection	39
6.14	Safety Representative	40
6.15	Hazard Communication Programs	40
6.16	Emergencies	40
6.17	Shop Drawings and Samples	40
6.18	Continuing the Work	42
6.19	Contractor’s General Warranty and Guarantee.....	43
6.20	Indemnification	43
6.21	Delegation of Professional Design Services	44
6.22	Standardization of Specifications	44
<hr/>		
Article 7 – Other Work at the Site.....		45
7.01	Related Work at Site	45
7.02	Coordination.....	46
7.03	Legal Relationships.....	46
7.04	Claims between Contractors.....	46
<hr/>		
Article 8 – Owner’s Responsibilities		47
8.01	Communications to Contractor.....	47
8.02	Replacement of Engineer.....	48
8.03	Furnish Data	48
8.04	Pay When Due	48
8.05	Lands and Easements; Reports and Tests	48
8.06	Insurance	48
8.07	Change Orders.....	48
8.08	Inspections, Tests, and Approvals	48
8.09	Limitations on Owner’s Responsibilities	48
8.10	Undisclosed Hazardous Environmental Condition.....	48
8.11	Evidence of Financial Arrangements	49
8.12	Compliance with Safety Program.....	49

Article 9 – Engineer’s Status During Construction	49
9.01 Owner’s Representative	49
9.02 Visits to Site	49
9.03 Project Representative	49
9.04 Authorized Variations in Work	52
9.05 Rejecting Defective Work	53
9.06 Shop Drawings, Change Orders and Payments	53
9.07 Determinations for Unit Price Work	53
9.08 Decisions on Requirements of Contract Documents and Acceptability of Work	53
9.09 Limitations on Engineer’s Authority and Responsibilities.....	54
9.10 Compliance with Safety Program.....	54
Article 10 – Changes in the Work; Claims	54
10.01 Authorized Changes in the Work	54
10.02 Unauthorized Changes in the Work	55
10.03 Execution of Change Orders.....	55
10.04 Notification to Surety.....	55
10.05 Claims.....	55
Article 11 – Cost of the Work; Allowances; Unit Price Work.....	57
11.01 Cost of the Work	57
11.02 Allowances	61
11.03 Unit Price Work	61
Article 12 – Change of Contract Price; Change of Contract Times.....	62
12.01 Change of Contract Price.....	62
12.02 Change of Contract Times	63
12.03 Delays.....	64
12.04 <u>No Damage for Delays</u>	<u>64</u>
Article 13 – Tests and Inspections; Correction, Removal or Acceptance of Defective Work.....	65
13.01 Notice of Defects	65
13.02 Access to Work	65
13.03 Tests and Inspections	65
13.04 Uncovering Work.....	68
13.05 Owner May Stop the Work.....	69
13.06 Correction or Removal of Defective Work.....	69
13.07 Correction Period	69
13.08 Acceptance of Defective Work	70
13.09 Owner May Correct Defective Work.....	70
Article 14 – Payments to Contractor and Completion.....	71
14.01 Schedule of Values	71
14.02 Progress Payments	71
14.03 Contractor’s Warranty of Title	75
14.04 Substantial Completion.....	75
14.05 Partial Utilization	76
14.06 Final Inspection.....	76

14.07 Final Payment	77
14.08 Final Completion Delayed.....	78
14.09 Waiver of Claims	78
Article 15 – Suspension of Work and Termination	78
15.01 Owner May Suspend Work	78
15.02 Owner May Terminate for Cause	79
15.03 Owner May Terminate For Convenience.....	80
15.04 Contractor May Stop Work or Terminate	81
Article 16 – Dispute Resolution	81
16.01 Methods and Procedures.....	81
Article 17 – Miscellaneous	82
17.01 Giving Notice.....	82
17.02 Computation of Times	82
17.03 Cumulative Remedies	82
17.04 Survival of Obligations	82
17.05 Controlling Law	82
17.06 Headings.....	83
<u>17.07 Assignment.....</u>	<u>83</u>

ARTICLE 1 – DEFINITIONS AND TERMINOLOGY

1.01 *Defined Terms*

- A. Wherever used in the Bidding Requirements or Contract Documents and printed with initial capital letters, the terms listed below will have the meanings indicated which are applicable to both the singular and plural thereof. In addition to terms specifically defined, terms with initial capital letters in the Contract Documents include references to identified articles and paragraphs, and the titles of other documents or forms.
1. *Addenda*—Written or graphic instruments issued prior to the opening of Bids which clarify, correct, or change the Bidding Requirements or the proposed Contract Documents.
 2. *Agreement*—The written instrument which is evidence of the agreement between Owner and Contractor covering the Services and the Work.
 3. *Application for Payment*—The form acceptable to Engineer which is to be used by Contractor during the course of the Work in requesting progress or final payments and which is to be accompanied by such supporting documentation as is required by the Contract Documents.
 4. *Asbestos*—Any material that contains more than one percent asbestos and is friable or is releasing asbestos fibers into the air above current action levels established by the United States Occupational Safety and Health Administration.
 5. *Bid*—The offer or proposal of a Bidder submitted on the prescribed form setting forth the prices for the Work to be performed.
 6. *Bidder*—~~The individual or entity who submits a Bid directly to Owner.~~ The Subcontractor, Supplier, individual or entity that submits a Bid or the CMAR that submits a Bid for self-performed Work.
 7. *Bidding Documents*—The Bidding Requirements and the proposed Contract Documents (including all Addenda).
 8. *Bidding Requirements*—The advertisement or invitation to bid, Instructions to Bidders, Bid security of acceptable form, if any, and the Bid Form with any supplements.
 9. *Change Order*—A document recommended by Engineer which is signed by Contractor and Owner and authorizes an addition, deletion, or revision in the Work or an adjustment in the Contract Price or the Contract Times, issued on or after the Effective Date of the Agreement.
 10. *Claim*—A demand or assertion by Owner or Contractor seeking an adjustment of Contract Price or Contract Times, or both, or other relief with respect to the terms of the Contract. A demand for money or services by a third party is not a Claim.
 11. *Contract*—The entire and integrated written agreement between the Owner and Contractor concerning the Services and the Work. The Contract supersedes prior negotiations, representations, or agreements, whether written or oral. Contract shall have the same meaning as Agreement.

12. *Contract Documents*—Those items so designated in the Agreement. Only printed or hard copies of the items listed in the Agreement are Contract Documents. Approved Shop Drawings, other Contractor submittals, and the reports and drawings of subsurface and physical conditions are not Contract Documents.
13. *Contract Price*—The moneys payable by Owner to Contractor for completion of the Work in accordance with the Contract Documents as stated in the Agreement (subject to the provisions of Paragraph 11.03 in the case of Unit Price Work).
14. *Contract Times*—The number of days or the dates stated in the Agreement to: (i) achieve Milestones, if any; (ii) achieve Substantial Completion; and (iii) complete the Work so that it is ready for final payment as evidenced by Engineer's written recommendation of final payment.
15. *Contractor*—~~The individual or entity with whom Owner has entered into the Agreement.~~ In these Contract Documents, Contractor has the same meaning as the Construction Manager at Risk and CMAR.
16. *Cost of the Work*—See Paragraph 11.01 for definition.
17. *Drawings*—That part of the Contract Documents prepared or approved by Engineer which graphically shows the scope, extent, and character of the Work to be performed by Contractor. Shop Drawings and other Contractor submittals are not Drawings as so defined.
18. *Effective Date of the Agreement*—The date indicated in the Agreement on which it becomes effective, but if no such date is indicated, it means the date on which the Agreement is signed and delivered by the last of the two parties to sign and deliver.
19. *Engineer*—The individual or entity named as such in the Agreement.
20. *Field Order*—A written order issued by Engineer which requires minor changes in the Work but which does not involve a change in the Contract Price or the Contract Times.
21. *General Requirements*—Sections of Division 1 of the Specifications.
22. *Hazardous Environmental Condition*—The presence at the Site of Asbestos, PCBs, Petroleum, Hazardous Waste, or Radioactive Material in such quantities or circumstances that may present a substantial danger to persons or property exposed thereto.
23. *Hazardous Waste*—The term Hazardous Waste shall have the meaning provided in Section 1004 of the Solid Waste Disposal Act (42 USC Section 6903) as amended from time to time.
24. *Laws and Regulations; Laws or Regulations*—Any and all applicable laws, rules, regulations, ordinances, codes, and orders of any and all governmental bodies, agencies, authorities, and courts having jurisdiction.
25. *Liens*—Charges, security interests, or encumbrances upon Project funds, real property, or personal property.

26. *Milestone*—A principal event specified in the Contract Documents relating to an intermediate completion date or time prior to Substantial Completion of all the Work.
27. *Notice of Award*—The written notice by Owner to the Successful Bidder stating that upon timely compliance by the Successful Bidder with the conditions precedent listed therein, Owner will sign and deliver the Agreement.
28. *Notice to Proceed*—A written notice given by Owner to Contractor fixing the date on which the Contract Times will commence to run and on which Contractor shall start to perform the Work under the Contract Documents.
29. *Owner*—The individual or entity with whom Contractor has entered into the Agreement and for whom the Work is to be performed.
30. *PCBs*—Polychlorinated biphenyls.
31. *Petroleum*—Petroleum, including crude oil or any fraction thereof which is liquid at standard conditions of temperature and pressure (60 degrees Fahrenheit and 14.7 pounds per square inch absolute), such as oil, petroleum, fuel oil, oil sludge, oil refuse, gasoline, kerosene, and oil mixed with other non-Hazardous Waste and crude oils.
32. *Progress Schedule*—A schedule, prepared and maintained by Contractor, describing the sequence and duration of the activities comprising the Contractor's plan to accomplish the Work within the Contract Times.
33. *Project*—The total construction of which the Work to be performed under the Contract Documents may be the whole, or a part.
34. *Project Manual*—The bound documentary information prepared for bidding and constructing the Work. A listing of the contents of the Project Manual, which may be bound in one or more volumes, is contained in the table(s) of contents.
35. *Radioactive Material*—Source, special nuclear, or byproduct material as defined by the Atomic Energy Act of 1954 (42 USC Section 2011 et seq.) as amended from time to time.
36. *Resident Project Representative*—The authorized representative of Engineer who may be assigned to the Site or any part thereof.
37. *Samples*—Physical examples of materials, equipment, or workmanship that are representative of some portion of the Work and which establish the standards by which such portion of the Work will be judged.
38. *Schedule of Submittals*—A schedule, prepared and maintained by Contractor, of required submittals and the time requirements to support scheduled performance of related construction activities.
39. *Schedule of Values*—A schedule, prepared and maintained by Contractor, allocating portions of the Contract Price to various portions of the Work and used as the basis for reviewing Contractor's Applications for Payment.

40. *Shop Drawings*—All drawings, diagrams, illustrations, schedules, and other data or information which are specifically prepared or assembled by or for Contractor and submitted by Contractor to illustrate some portion of the Work.
41. *Site*—Lands or areas indicated in the Contract Documents as being furnished by Owner upon which the Work is to be performed, including rights-of-way and easements for access thereto, and such other lands furnished by Owner which are designated for the use of Contractor.
42. *Specifications*—That part of the Contract Documents consisting of written requirements for materials, equipment, systems, standards and workmanship as applied to the Work, and certain administrative requirements and procedural matters applicable thereto.
43. *Subcontractor*—An individual or entity having a direct contract with Contractor or with any other Subcontractor for the performance of a part of the Work at the Site.
44. *Substantial Completion*—The time at which the Work (or a specified part thereof) has progressed to the point where, in the opinion of Engineer, the Work (or a specified part thereof) is sufficiently complete, in accordance with the Contract Documents, so that the Work (or a specified part thereof) can be utilized for the purposes for which it is intended. The terms “substantially complete” and “substantially completed” as applied to all or part of the Work refer to Substantial Completion thereof.
45. *Successful Bidder*—The Bidder submitting a responsive Bid to whom Owner makes an award.
46. *Supplementary Conditions*—That part of the Contract Documents which amends or supplements these General Conditions.
47. *Supplier*—A manufacturer, fabricator, supplier, distributor, materialman, or vendor having a direct contract with Contractor or with any Subcontractor to furnish materials or equipment to be incorporated in the Work by Contractor or Subcontractor.
48. *Underground Facilities*—All underground pipelines, conduits, ducts, cables, wires, manholes, vaults, tanks, tunnels, or other such facilities or attachments, and any encasements containing such facilities, including those that convey electricity, gases, steam, liquid petroleum products, telephone or other communications, cable television, water, wastewater, storm water, other liquids or chemicals, or traffic or other control systems.
49. *Unit Price Work*—Work to be paid for on the basis of unit prices.
50. *Work*—The entire construction or the various separately identifiable parts thereof required to be provided under the Contract Documents. Work includes and is the result of performing or providing all labor, services, and documentation necessary to produce such construction, and furnishing, installing, and incorporating all materials and equipment into such construction, all as required by the Contract Documents.
51. *Work Change Directive*—A written statement to Contractor issued on or after the Effective Date of the Agreement and signed by Owner and recommended by Engineer ordering an addition, deletion, or revision in the Work, or responding to differing or unforeseen subsurface or physical conditions under which the Work is to be performed or to emergencies. A Work

Change Directive will not change the Contract Price or the Contract Times but is evidence that the parties expect that the change ordered or documented by a Work Change Directive will be incorporated in a subsequently issued Change Order following negotiations by the parties as to its effect, if any, on the Contract Price or Contract Times.

52. Construction Manager at Risk or CMAR—The individual or entity with whom Owner has entered into the Agreement. The terms CMAR, Construction Manager at Risk and Contractor shall have the same meaning in these Contract Documents.
53. Owner's Budget—The amount budgeted by the Owner for the Services and the Work.
54. Guaranteed Maximum Price—The sum of the Construction Manager at Risk's construction services fee (CMAR Fee) established under Article 6 of the Agreement, the Cost of the Work established under Article 7 of the Agreement and expenditures for contingency funds as determined in Article 8 of the Agreement. Guaranteed Maximum Price shall have the same meaning as GMP.
55. Proposal Security—The financial security in the form of a bid bond provided by Proposer to the Owner at the time the Proposal is submitted until Performance, Payment and other bonds required by the Contract Documents in the amount of 100% of the Owner's Budget or Guaranteed Maximum Price are provided.
56. Modification—(a) Amendment; (b) Change Order; (c) Field Order; or (d) Work Change Directive.
57. Amendment—a written amendment to the Agreement that is duly authorized, approved or ratified by the Owner and duly authorized by the CMAR that provides for a material change, alteration or revision to the terms and conditions of the Agreement.
58. Guaranteed Maximum Price Proposal ("GMP Proposal")—means the proposal submitted by the CMAR which sets forth its GMP and all assumptions and clarifications concerning the Contract Documents and Project and the Scope of Work upon which the GMP is based. This term can be used for either the GMP Proposal for the entire Work or an Early Work Package GMP Proposal.
59. Guaranteed Maximum Price Amendment ("GMP Amendment")—means the document described in Article 9 of the Agreement, which is incorporated herein by reference.
60. Value Analysis—means the systematic application of recognized techniques by a multidiscipline team to identify the function of a product or service, establish a worth for that function, generate alternatives through the use of creative thinking and provide needed modifications to accomplish the original purpose of the Project, reliably, without sacrificing safety, necessary quality and environmental and performance attributes of the Project.
61. CMAR Team—means the team formed by the Proposer for purposes of responding to the RFP.
62. CMAR Team Member—means a corporate entity or firm or individual included in the CMAR Team or identified in the Proposal that will provide any of the Services for this Project.

1.02 Terminology

A. The words and terms discussed in Paragraph 1.02.B through F are not defined but, when used in the Bidding Requirements or Contract Documents, have the indicated meaning.

B. *Intent of Certain Terms or Adjectives:*

1. The Contract Documents include the terms “as allowed,” “as approved,” “as ordered,” “as directed” or terms of like effect or import to authorize an exercise of professional judgment by Engineer. In addition, the adjectives “reasonable,” “suitable,” “acceptable,” “proper,” “satisfactory,” or adjectives of like effect or import are used to describe an action or determination of Engineer as to the Work. It is intended that such exercise of professional judgment, action, or determination will be solely to evaluate, in general, the Work for compliance with the information in the Contract Documents and with the design concept of the Project as a functioning whole as shown or indicated in the Contract Documents (unless there is a specific statement indicating otherwise). The use of any such term or adjective is not intended to and shall not be effective to assign to Engineer any duty or authority to supervise or direct the performance of the Work, or any duty or authority to undertake responsibility contrary to the provisions of Paragraph 9.09 or any other provision of the Contract Documents.
2. “At no additional cost to Owner”, “With no extra compensation to CMAR”, “At CMAR’s own expense”, or similar words mean that the CMAR will perform the Work without any increase in the Contract Price. It is understood that the Cost of the Work is included in the Contract Price and will be performed at no additional cost to the Owner unless specifically stated otherwise.

C. *Day:*

1. ~~The word “day” means a calendar day of 24 hours measured from midnight to the next midnight.~~ A “Calendar Day” shall be a day of 24 hours measured from midnight to the next midnight, and is any day of the year, with no days being excluded.
2. A “Working Day” shall be a day which permits construction of the principal units of the Work for a period of not less than 7 hours between 7:00 a.m. and 6:00 p.m. Working Days do not include days on which weather or other conditions not under the control of the CMAR prevent CMAR from working the 7 hours defining a Working Day. Working Days do not include Saturdays, Sundays or any of the following holidays: New Year, Good Friday, Memorial Day, Independence Day, Labor Day, Thanksgiving Day, the day after Thanksgiving and Christmas Eve and Christmas Day.

D. *Defective:*

1. The word “defective,” when modifying the word “Work,” refers to Work that is unsatisfactory, faulty, or deficient in that it:
 - a. does not conform to the Contract Documents; or
 - b. does not meet the requirements of any applicable inspection, reference standard, test, or approval referred to in the Contract Documents; or

- c. has been damaged prior to Engineer's recommendation of final payment (unless responsibility for the protection thereof has been assumed by Owner at Substantial Completion in accordance with Paragraph 14.04 or 14.05).

E. *Furnish, Install, Perform, Provide:*

1. The word "furnish," when used in connection with services, materials, or equipment, shall mean to supply and deliver said services, materials, or equipment to the Site (or some other specified location) ready for use or installation and in usable or operable condition.
2. The word "install," when used in connection with services, materials, or equipment, shall mean to put into use or place in final position said services, materials, or equipment complete and ready for intended use.
3. The words "perform" or "provide," when used in connection with services, materials, or equipment, shall mean to furnish and install said services, materials, or equipment complete and ready for intended use.
4. When "furnish," "install," "perform," or "provide" is not used in connection with services, materials, or equipment in a context clearly requiring an obligation of Contractor, "provide" is implied.
5. Specifications are written in modified brief style. Requirements apply to all Work of the same kind, class, and type even though the word "all" is not stated.
6. Simple imperative sentence structure is used which places a verb as the first word in the sentence. It is understood that the words "furnish", "install", "provide", or similar words include the meaning of the phrase "The CMAR shall..." before these words.

- F. Unless stated otherwise in the Contract Documents, words or phrases that have a well-known technical or construction industry or trade meaning are used in the Contract Documents in accordance with such recognized meaning.

ARTICLE 2 – PRELIMINARY MATTERS

2.01 *Delivery of Bonds and Evidence of Insurance*

- A. When Contractor delivers the executed counterparts of the Agreement to Owner, Contractor shall also deliver to Owner such bonds as Contractor may be required to furnish.
- B. *Evidence of Insurance:* Before any Work at the Site is started, Contractor and Owner shall each deliver to the other, with copies to each additional insured identified in the Supplementary Conditions, certificates of insurance (and other evidence of insurance which either of them or any additional insured may reasonably request) which Contractor and Owner respectively are required to purchase and maintain in accordance with Article 5.

2.02 *Copies of Documents*

- A. Owner shall furnish to Contractor up to ~~ten~~ five printed or hard copies of the Drawings and Project Manual. Additional copies will be furnished upon request at the cost of reproduction.

2.03 *Commencement of Contract Times; Notice to Proceed*

- A. The Contract Times will commence to run on the thirtieth day after the Effective Date of the Agreement or, if a Notice to Proceed is given, on the day indicated in the Notice to Proceed. A Notice to Proceed may be given at any time within 30 days after the Effective Date of the Agreement. In no event will the Contract Times commence to run later than the sixtieth day after the day of Bid opening or the thirtieth day after the Effective Date of the Agreement, whichever date is earlier.

2.04 *Starting the Work*

- A. Contractor shall start to perform the Work on the date when the Contract Times commence to run. No Work shall be done at the Site prior to the date on which the Contract Times commence to run.

2.05 *Before Starting Construction*

- A. *Preliminary Schedules:* Within 10 days after the Effective Date of the Agreement (unless otherwise specified in the General Requirements), Contractor shall submit to Engineer for timely review:
1. a preliminary Progress Schedule indicating the times (numbers of days or dates) for starting and completing the various stages of the Work, including any Milestones specified in the Contract Documents;
 2. a preliminary Schedule of Submittals; and
 3. a preliminary Schedule of Values for all of the Work which includes quantities and prices of items which when added together equal the Contract Price and subdivides the Work into component parts in sufficient detail to serve as the basis for progress payments during performance of the Work. Such prices will include an appropriate amount of overhead and profit applicable to each item of Work.
- B. Before undertaking each part of the Work, CMAR shall carefully study and compare the Contract Documents and check and verify pertinent figures shown thereon and all applicable field measurements. CMAR shall promptly report in writing to the Engineer any conflict, error, ambiguity or discrepancy which the CMAR may discover and shall obtain a written interpretation from the Engineer before proceeding with any Work affected thereby. In the event of a conflict in the Drawings, Specifications, or other portions of the Contract Documents that were not reported to Owner prior to the submission of any applicable early work package or the GMP Proposal, the CMAR shall be deemed to have included the most expensive item in their early work package proposal or GMP Proposal.

2.06 *Preconstruction Conference; Designation of Authorized Representatives*

- A. Before any Work at the Site is started, a conference attended by Owner, Contractor, Engineer, and others as appropriate will be held to establish a working understanding among the parties as to the Work and to discuss the schedules referred to in Paragraph 2.05.A, procedures for handling Shop Drawings and other submittals, processing Applications for Payment, and maintaining required records.

- B. At this conference Owner and Contractor each shall designate, in writing, a specific individual to act as its authorized representative with respect to the services and responsibilities under the Contract. Such individuals shall have the authority to transmit instructions, receive information, render decisions relative to the Contract, and otherwise act on behalf of each respective party.

2.07 *Initial Acceptance of Schedules*

- A. At least 10 days before submission of the first Application for Payment a conference attended by Contractor, Engineer, and others as appropriate will be held to review for acceptability to Engineer as provided below the schedules submitted in accordance with Paragraph 2.05.A. Contractor shall have an additional 10 days to make corrections and adjustments and to complete and resubmit the schedules. No progress payment shall be made to Contractor until acceptable schedules are submitted to Engineer.
1. The Progress Schedule will be acceptable to Engineer if it provides an orderly progression of the Work to completion within the Contract Times. Such acceptance will not impose on Engineer responsibility for the Progress Schedule, for sequencing, scheduling, or progress of the Work, nor interfere with or relieve Contractor from Contractor's full responsibility therefor.
 2. Contractor's Schedule of Submittals will be acceptable to Engineer if it provides a workable arrangement for reviewing and processing the required submittals.
 3. Contractor's Schedule of Values will be acceptable to Engineer as to form and substance if it provides a reasonable allocation of the Contract Price to component parts of the Work.

ARTICLE 3 – CONTRACT DOCUMENTS: INTENT, AMENDING, REUSE

3.01 *Intent*

- A. The Contract Documents are complementary; what is required by one is as binding as if required by all. Drawings and Specifications do not indicate or describe all of the Work required to complete the Project. Additional details required for the correct installation of selected products are to be provided by the CMAR and coordinated with the Engineer. Provide any Work, materials or equipment required for a complete and functional system even if they are not detailed or specified.
1. The Contract requirements described in the General Conditions, Supplementary Conditions and General Requirements apply to each and all Specification Sections unless specifically noted otherwise.
 2. Organization of Contract Documents is not intended to control or to lessen the responsibility of the CMAR when dividing Work among Subcontractors, or to establish the extent of Work to be performed by any trade, Subcontractor or Supplier. Specifications or details do not need to be indicated or specified in each Specification or Drawing. Items shown in the Contract Documents are applicable regardless of location in the Contract Documents.

3. Standard paragraph titles and other identifications of subject matter in the Specifications are intended to aid in locating and recognizing various requirements of the Specifications. Titles do not define, limit, or otherwise restrict Specification text.
- B. It is the intent of the Contract Documents to describe a functionally complete project (or part thereof) to be constructed in accordance with the Contract Documents. Any labor, documentation, services, materials, or equipment that reasonably may be inferred from the Contract Documents or from prevailing custom or trade usage as being required to produce the indicated result will be provided whether or not specifically called for, at no additional cost to Owner.
- C. Clarifications and interpretations of the Contract Documents shall be issued by Engineer as provided in Article 9.
- D. Comply with the most stringent requirements where compliance with two or more standards is specified, and they establish different or conflicting requirements for minimum quantities or quality levels, unless Contract Documents indicate otherwise.

Quantity or quality level shown or indicated shall be minimum to be provided or performed in every instance.

Actual installation may comply exactly with minimum quality indicated, or it may exceed that minimum within reasonable limits.

In complying with these requirements, indicated numeric values are minimum or maximum values, as noted, or appropriate for context of requirements.

Refer instances of uncertainty to the Engineer for a decision before proceeding.
- E. Provide materials and equipment comparable in quality to similar materials and equipment incorporated in the Project or as required to meet the minimum requirements of the application if the materials and equipment are shown in the Drawings but are not included in the Specifications.
- F. The Contract Documents comprise the entire Agreement between Owner and CMAR. The Contract Documents may be modified only by Amendment or Field Order or Change Order.

3.02 *Reference Standards*

- A. Standards, Specifications, Codes, Laws, and Regulations
 1. Reference to standards, specifications, manuals, or codes of any technical society, organization, or association, or to Laws or Regulations, whether such reference be specific or by implication, shall mean the standard, specification, manual, code, or Laws or Regulations in effect at the time of opening of Bids (or on the Effective Date of the Agreement if there were no Bids), except as may be otherwise specifically stated in the Contract Documents.
 2. No provision of any such standard, specification, manual, or code, or any instruction of a Supplier, shall be effective to change the duties or responsibilities of Owner, Contractor, or Engineer, or any of their subcontractors, consultants, agents, or employees, from those set forth in the Contract Documents. No such provision or instruction shall be effective to assign to Owner, Engineer, or any of their officers, directors, members, partners, employees, agents, consultants, or subcontractors, any duty or authority to supervise or direct the performance of

the Work or any duty or authority to undertake responsibility inconsistent with the provisions of the Contract Documents.

- B. Comply with applicable construction industry standards as if bound or copied directly into the Contract Documents regardless of lack of reference in the Contract Documents. Apply provisions of the Contract Documents where Contract Documents include more stringent requirements than the referenced standards.

Standards referenced directly in the Contract Documents take precedence over standards that are not referenced but recognized in the construction industry as applicable.

Comply with standards not referenced but recognized in the construction industry as applicable for performance of the Work except as otherwise limited by the Contract Documents. The Engineer determines whether code or standard is applicable, or which of several are applicable.

Make copies of reference standards available as requested by Engineer or Owner.

3.03 *Reporting and Resolving Discrepancies*

A. *Reporting Discrepancies:*

1. *Contractor's Review of Contract Documents Before Starting Work:* Before undertaking each part of the Work, Contractor shall carefully study and compare the Contract Documents and check and verify pertinent figures therein and all applicable field measurements. Contractor shall promptly report in writing to Engineer any conflict, error, ambiguity, or discrepancy which Contractor discovers, or has actual knowledge of, and shall obtain a written interpretation or clarification from Engineer before proceeding with any Work affected thereby.
 - a. CMAR represents that he has familiarized himself with the nature and extent of the Contract Documents, Work, location, all local conditions, and Laws and Regulations that in any manner may affect performance of the Work, and represents that he has correlated his study and observations with the requirements of the Contract Documents. CMAR also represents that he has studied all conditions referred to in the Contract Documents and will make such additional surveys and investigations as he deems necessary for the performance of the Work at the Contract price in accordance with the requirements of the Contract Documents and that he has correlated the results of all such data with the requirements of the Contract Documents.
2. *Contractor's Review of Contract Documents During Performance of Work:* If, during the performance of the Work, Contractor discovers any conflict, error, ambiguity, or discrepancy within the Contract Documents, or between the Contract Documents and (a) any applicable Law or Regulation, (b) any standard, specification, manual, or code, or (c) any instruction of any Supplier, then Contractor shall promptly report it to Engineer in writing. Contractor shall not proceed with the Work affected thereby (except in an emergency as required by Paragraph 6.16.A) until an amendment or supplement to the Contract Documents has been issued by one of the methods indicated in Paragraph 3.04.
3. ~~Contractor shall not be liable to Owner or Engineer for failure to report any conflict, error, ambiguity, or discrepancy in the Contract Documents unless Contractor had actual knowledge~~

thereof. In the event of a conflict in the Drawings, Specifications, or other portions of the Contract Documents which were not reported prior to the submission of any applicable early work package or the GMP Proposal, the CMAR shall be deemed to have included the most expensive item, system, procedure, etc. in his submission of the early work package proposal or GMP Proposal.

B. *Resolving Discrepancies:*

1. Except as may be otherwise specifically stated in the Contract Documents, the provisions of the Contract Documents shall take precedence in resolving any conflict, error, ambiguity, or discrepancy between the provisions of the Contract Documents and:
 - a. the provisions of any standard, specification, manual, or code, or the instruction of any Supplier (whether or not specifically incorporated by reference in the Contract Documents); or
 - b. the provisions of any Laws or Regulations applicable to the performance of the Work (unless such an interpretation of the provisions of the Contract Documents would result in violation of such Law or Regulation).

3.04 *Amending and Supplementing Contract Documents*

- A. The Contract Documents may be amended to provide for additions, deletions, and revisions in the Work or to modify the terms and conditions thereof by either a Change Order or a Work Change Directive.
- B. The requirements of the Contract Documents may be supplemented, and minor variations and deviations in the Work may be authorized, by one or more of the following ways:
 1. A Field Order;
 2. Engineer's approval of a Shop Drawing or Sample (subject to the provisions of Paragraph 6.17.D.3); or
 3. Engineer's written interpretation or clarification.

3.05 *Reuse of Documents*

- A. Contractor and any Subcontractor or Supplier shall not:
 1. have or acquire any title to or ownership rights in any of the Drawings, Specifications, or other documents (or copies of any thereof) prepared by or bearing the seal of Engineer or its consultants, including electronic media editions; or
 2. reuse any such Drawings, Specifications, other documents, or copies thereof on extensions of the Project or any other project without written consent of Owner and Engineer and specific written verification or adaptation by Engineer.
- B. The prohibitions of this Paragraph 3.05 will survive final payment, or termination of the Contract. ~~Nothing herein shall preclude Contractor from retaining copies of the Contract Documents for~~

record purposes. Nothing herein shall preclude CMAR from retaining copies of the Contract Documents for record purposes, unless specifically prohibited in writing by the Owner for security reasons. If the Owner so directs, CMAR shall surrender all copies of the construction Contract Documents and other related documents, in paper or digital format and remove these documents from computer equipment or storage devices as a condition of final payment.

3.06 *Electronic Data*

- A. Unless otherwise stated in the Supplementary Conditions, the data furnished by Owner or Engineer to Contractor, or by Contractor to Owner or Engineer, that may be relied upon are limited to the printed copies (also known as hard copies). Files in electronic media format of text, data, graphics, or other types are furnished only for the convenience of the receiving party. Any conclusion or information obtained or derived from such electronic files will be at the user's sole risk. If there is a discrepancy between the electronic files and the hard copies, the hard copies govern.
- B. Because data stored in electronic media format can deteriorate or be modified inadvertently or otherwise without authorization of the data's creator, the party receiving electronic files agrees that it will perform acceptance tests or procedures within 60 days, after which the receiving party shall be deemed to have accepted the data thus transferred. Any errors detected within the 60-day acceptance period will be corrected by the transferring party.
- C. When transferring documents in electronic media format, the transferring party makes no representations as to long term compatibility, usability, or readability of documents resulting from the use of software application packages, operating systems, or computer hardware differing from those used by the data's creator.

ARTICLE 4 – AVAILABILITY OF LANDS; SUBSURFACE AND PHYSICAL CONDITIONS; HAZARDOUS ENVIRONMENTAL CONDITIONS; REFERENCE POINTS

4.01 *Availability of Lands*

- A. Owner shall furnish the Site. Owner shall notify Contractor of any encumbrances or restrictions not of general application but specifically related to use of the Site with which Contractor must comply in performing the Work. Owner will obtain in a timely manner and pay for easements for permanent structures or permanent changes in existing facilities. If Contractor and Owner are unable to agree on entitlement to or on the amount or extent, if any, of any adjustment in the Contract Price or Contract Times, or both, as a result of any delay in Owner's furnishing the Site or a part thereof, Contractor may make a Claim therefor as provided in Paragraph 10.05.
- B. Upon reasonable written request, Owner shall furnish Contractor with a current statement of record legal title and legal description of the lands upon which the Work is to be performed and Owner's interest therein as necessary for giving notice of or filing a mechanic's or construction lien against such lands in accordance with applicable Laws and Regulations.
- C. ~~Contractor shall provide for all additional lands and access thereto that may be required for temporary construction facilities or storage of materials and equipment.~~ CMAR shall provide for all additional lands and access thereto that may be required for temporary construction facilities

or storage of materials and equipment. A copy of the written agreements for the use of such land shall be provided to the Owner for record purposes.

4.02 *Subsurface and Physical Conditions*

A. *Reports and Drawings:* The Supplementary Conditions identify:

1. those reports known to Owner of explorations and tests of subsurface conditions at or contiguous to the Site; and
2. those drawings known to Owner of physical conditions relating to existing surface or subsurface structures at the Site (except Underground Facilities).

B. *Limited Reliance by Contractor on Technical Data Authorized:* Contractor may rely upon the accuracy of the “technical data” contained in such reports and drawings, but such reports and drawings are not Contract Documents. Such “technical data” is identified in the Supplementary Conditions. Except for such reliance on such “technical data,” Contractor may not rely upon or make any claim against Owner or Engineer, or any of their officers, directors, members, partners, employees, agents, consultants, or subcontractors with respect to:

1. the completeness of such reports and drawings for Contractor’s purposes, including, but not limited to, any aspects of the means, methods, techniques, sequences, and procedures of construction to be employed by Contractor, and safety precautions and programs incident thereto; or
2. other data, interpretations, opinions, and information contained in such reports or shown or indicated in such drawings; or
3. any Contractor interpretation of or conclusion drawn from any “technical data” or any such other data, interpretations, opinions, or information.

4.03 *Differing Subsurface or Physical Conditions*

A. *Notice:* If Contractor believes that any subsurface or physical condition that is uncovered or revealed either:

1. is of such a nature as to establish that any “technical data” on which Contractor is entitled to rely as provided in Paragraph 4.02 is materially inaccurate; or
2. is of such a nature as to require a change in the Contract Documents; or
3. differs materially from that shown or indicated in the Contract Documents; or
4. is of an unusual nature, and differs materially from conditions ordinarily encountered and generally recognized as inherent in work of the character provided for in the Contract Documents;

then Contractor shall, promptly but no later than within 3 days after becoming aware thereof and before further disturbing the subsurface or physical conditions or performing any Work in connection therewith (except in an emergency as required by Paragraph 6.16.A), notify Owner

and Engineer in writing about such condition. Contractor shall not further disturb such condition or perform any Work in connection therewith (except as aforesaid) until receipt of written order to do so.

B. *Engineer's Review:* After receipt of written notice as required by Paragraph 4.03.A, Engineer will promptly review the pertinent condition, determine the necessity of Owner's obtaining additional exploration or tests with respect thereto, and advise Owner in writing (with a copy to Contractor) of Engineer's findings and conclusions.

C. *Possible Price and Times Adjustments:*

1. The Contract Price or the Contract Times, or both, will be equitably adjusted to the extent that the existence of such differing subsurface or physical condition causes an increase or decrease in Contractor's cost of, or time required for, performance of the Work; subject, however, to the following:
 - a. such condition must meet any one or more of the categories described in Paragraph 4.03.A; and
 - b. with respect to Work that is paid for on a unit price basis, any adjustment in Contract Price will be subject to the provisions of Paragraphs 9.07 and 11.03.
2. Contractor shall not be entitled to any adjustment in the Contract Price or Contract Times if:
 - a. Contractor knew of the existence of such conditions at the time Contractor made a final commitment to Owner with respect to Contract Price and Contract Times by the submission of a Bid or becoming bound under a negotiated contract; or
 - b. the existence of such condition could reasonably have been discovered or revealed as a result of any examination, investigation, exploration, test, or study of the Site and contiguous areas required by the Bidding Requirements or Contract Documents to be conducted by or for Contractor prior to Contractor's making such final commitment; or
 - c. Contractor failed to give the timely written notice as required by Paragraph 4.03.A.
3. If Owner and Contractor are unable to agree on entitlement to or on the amount or extent, if any, of any adjustment in the Contract Price or Contract Times, or both, a Claim may be made therefor as provided in Paragraph 10.05. However, neither Owner or Engineer, or any of their officers, directors, members, partners, employees, agents, consultants, or subcontractors shall be liable to Contractor for any claims, costs, losses, or damages (including but not limited to all fees and charges of engineers, architects, attorneys, and other professionals and all court or arbitration or other dispute resolution costs) sustained by Contractor on or in connection with any other project or anticipated project.

4.04 *Underground Facilities*

A. *Shown or Indicated:* The information and data shown or indicated in the Contract Documents with respect to existing Underground Facilities at or contiguous to the Site is based on information

and data furnished to Owner or Engineer by the owners of such Underground Facilities, including Owner, or by others. Unless it is otherwise expressly provided in the Supplementary Conditions:

1. Owner and Engineer shall not be responsible for the accuracy or completeness of any such information or data provided by others; and
2. the cost of all of the following will be included in the Contract Price, and Contractor shall have full responsibility for:
 - a. reviewing and checking all such information and data;
 - b. locating all Underground Facilities shown or indicated in the Contract Documents;
 - c. coordination of the Work with the owners of such Underground Facilities, including Owner, during construction; and
 - d. the safety and protection of all such Underground Facilities and repairing any damage thereto resulting from the Work.

B. Not Shown or Indicated:

1. If an Underground Facility is uncovered or revealed at or contiguous to the Site which was not shown or indicated, or not shown or indicated with reasonable accuracy in the Contract Documents, Contractor shall, promptly but no later than within 3 days after becoming aware thereof and before further disturbing conditions affected thereby or performing any Work in connection therewith (except in an emergency as required by Paragraph 6.16.A), identify the owner of such Underground Facility and give written notice to that owner and to Owner and Engineer. Engineer will promptly review the Underground Facility and determine the extent, if any, to which a change is required in the Contract Documents to reflect and document the consequences of the existence or location of the Underground Facility. During such time, Contractor shall be responsible for the safety and protection of such Underground Facility.
2. If Engineer concludes that a change in the Contract Documents is required, a Work Change Directive or a Change Order will be issued to reflect and document such consequences. An equitable adjustment shall be made in the Contract Price or Contract Times, or both, to the extent that they are attributable to the existence or location of any Underground Facility that was not shown or indicated or not shown or indicated with reasonable accuracy in the Contract Documents and that Contractor did not know of and could not reasonably have been expected to be aware of or to have anticipated. If Owner and Contractor are unable to agree on entitlement to or on the amount or extent, if any, of any such adjustment in Contract Price or Contract Times, Owner or Contractor may make a Claim therefor as provided in Paragraph 10.05.

4.05 Reference Points

- A. Owner shall provide engineering surveys to establish reference points for construction which in Engineer's judgment are necessary to enable Contractor to proceed with the Work. Contractor shall be responsible for laying out the Work, shall protect and preserve the established reference points and property monuments, and shall make no changes or relocations without the prior written

approval of Owner. Contractor shall report to Engineer whenever any reference point or property monument is lost or destroyed or requires relocation because of necessary changes in grades or locations, and shall be responsible for the accurate replacement or relocation of such reference points or property monuments by professionally qualified personnel.

4.06 *Hazardous Environmental Condition at Site*

~~A. *Reports and Drawings:* The Supplementary Conditions identify those reports and drawings known to Owner relating to Hazardous Environmental Conditions that have been identified at the Site.~~

A. No reports or drawings related to Hazardous Environmental Conditions at the Site are known to Owner.

~~B. *Limited Reliance by Contractor on Technical Data Authorized:* Contractor may rely upon the accuracy of the “technical data” contained in such reports and drawings, but such reports and drawings are not Contract Documents. Such “technical data” is identified in the Supplementary Conditions. Except for such reliance on such “technical data,” Contractor may not rely upon or make any claim against Owner or Engineer, or any of their officers, directors, members, partners, employees, agents, consultants, or subcontractors with respect to:~~

- ~~1. the completeness of such reports and drawings for Contractor’s purposes, including, but not limited to, any aspects of the means, methods, techniques, sequences and procedures of construction to be employed by Contractor and safety precautions and programs incident thereto; or~~
- ~~2. other data, interpretations, opinions and information contained in such reports or shown or indicated in such drawings; or~~
- ~~3. any Contractor interpretation of or conclusion drawn from any “technical data” or any such other data, interpretations, opinions or information.~~

C. Contractor shall not be responsible for any Hazardous Environmental Condition uncovered or revealed at the Site which was not shown or indicated in Drawings or Specifications or identified in the Contract Documents to be within the scope of the Work. Contractor shall be responsible for a Hazardous Environmental Condition created with any materials brought to the Site by Contractor, Subcontractors, Suppliers, or anyone else for whom Contractor is responsible.

D. If Contractor encounters a Hazardous Environmental Condition or if Contractor or anyone for whom Contractor is responsible creates a Hazardous Environmental Condition, Contractor shall immediately: (i) secure or otherwise isolate such condition; (ii) stop all Work in connection with such condition and in any area affected thereby (except in an emergency as required by Paragraph 6.16.A); and (iii) notify Owner and Engineer (and promptly thereafter confirm such notice in writing). Owner shall promptly consult with Engineer concerning the necessity for Owner to retain a qualified expert to evaluate such condition or take corrective action, if any. Promptly after consulting with Engineer, Owner shall take such actions as are necessary to permit Owner to timely obtain required permits and provide Contractor the written notice required by Paragraph 4.06.E.

- E. Contractor shall not be required to resume Work in connection with such condition or in any affected area until after Owner has obtained any required permits related thereto and delivered written notice to Contractor: (i) specifying that such condition and any affected area is or has been rendered safe for the resumption of Work; or (ii) specifying any special conditions under which such Work may be resumed safely. If Owner and Contractor cannot agree as to entitlement to or on the amount or extent, if any, of any adjustment in Contract Price or Contract Times, or both, as a result of such Work stoppage or such special conditions under which Work is agreed to be resumed by Contractor, either party may make a Claim therefor as provided in Paragraph 10.05.
- F. If after receipt of such written notice Contractor does not agree to resume such Work based on a reasonable belief it is unsafe, or does not agree to resume such Work under such special conditions, then Owner may order the portion of the Work that is in the area affected by such condition to be deleted from the Work. If Owner and Contractor cannot agree as to entitlement to or on the amount or extent, if any, of an adjustment in Contract Price or Contract Times as a result of deleting such portion of the Work, then either party may make a Claim therefor as provided in Paragraph 10.05. Owner may have such deleted portion of the Work performed by Owner's own forces or others in accordance with Article 7.
- G. ~~To the fullest extent permitted by Laws and Regulations, Owner shall indemnify and hold harmless Contractor, Subcontractors, and Engineer, and the officers, directors, members, partners, employees, agents, consultants, and subcontractors of each and any of them from and against all claims, costs, losses, and damages (including but not limited to all fees and charges of engineers, architects, attorneys, and other professionals and all court or arbitration or other dispute resolution costs) arising out of or relating to a Hazardous Environmental Condition, provided that such Hazardous Environmental Condition: (i) was not shown or indicated in the Drawings or Specifications or identified in the Contract Documents to be included within the scope of the Work, and (ii) was not created by Contractor or by anyone for whom Contractor is responsible. Nothing in this Paragraph 4.06.G shall obligate Owner to indemnify any individual or entity from and against the consequences of that individual's or entity's own negligence. TO THE FULLEST EXTENT PERMITTED BY LAWS AND REGULATIONS, OWNER SHALL DEFEND, INDEMNIFY AND HOLD HARMLESS CMAR, AND SUBCONTRACTORS AND THE OFFICERS, DIRECTORS, MEMBERS, PARTNERS, EMPLOYEES, AGENTS, CONSULTANTS, AND SUBCONTRACTORS OF EACH AND ANY OF THEM FROM AND AGAINST ALL CLAIMS, COSTS, LOSSES, AND DAMAGES (INCLUDING BUT NOT LIMITED TO ALL FEES AND CHARGES OF ENGINEERS, ARCHITECTS, ATTORNEYS, AND OTHER PROFESSIONALS AND ALL COURT OR ARBITRATION OR OTHER DISPUTE RESOLUTION COSTS) ARISING OUT OF OR RELATING TO A HAZARDOUS ENVIRONMENTAL CONDITION, PROVIDED THAT SUCH HAZARDOUS ENVIRONMENTAL CONDITION: (I) WAS NOT SHOWN OR INDICATED IN THE DRAWINGS OR SPECIFICATIONS OR IDENTIFIED IN THE CONTRACT DOCUMENTS TO BE INCLUDED WITHIN THE SCOPE OF THE WORK, AND (II) WAS NOT CREATED BY CMAR OR BY ANYONE FOR WHOM CMAR IS RESPONSIBLE. NOTHING IN THIS PARAGRAPH 4.06.G SHALL OBLIGATE OWNER TO INDEMNIFY ANY INDIVIDUAL OR ENTITY FROM AND AGAINST THE CONSEQUENCES OF THAT INDIVIDUAL'S OR ENTITY'S OWN NEGLIGENCE.~~
- H. ~~To the fullest extent permitted by Laws and Regulations, Contractor shall indemnify and hold harmless Owner and Engineer, and the officers, directors, members, partners, employees, agents, consultants, and subcontractors of each and any of them from and against all claims, costs, losses, and damages (including but not limited to all fees and charges of engineers, architects, attorneys, and other professionals and all court or arbitration or other dispute resolution costs) arising out of~~

or relating to a Hazardous Environmental Condition created by Contractor or by anyone for whom Contractor is responsible. Nothing in this Paragraph 4.06.H shall obligate Contractor to indemnify any individual or entity from and against the consequences of that individual's or entity's own negligence. TO THE FULLEST EXTENT PERMITTED BY LAWS AND REGULATIONS, CMAR SHALL DEFEND, INDEMNIFY AND HOLD HARMLESS OWNER AND ENGINEER, AND THE OFFICERS, DIRECTORS, MEMBERS, PARTNERS, EMPLOYEES, AGENTS, CONSULTANTS, AND SUBCONTRACTORS OF EACH AND ANY OF THEM FROM AND AGAINST ALL CLAIMS, COSTS, LOSSES, AND DAMAGES (INCLUDING BUT NOT LIMITED TO ALL FEES AND CHARGES OF ENGINEERS, ARCHITECTS, ATTORNEYS, AND OTHER PROFESSIONALS AND ALL COURT OR ARBITRATION OR OTHER DISPUTE RESOLUTION COSTS) ARISING OUT OF OR RELATING TO A HAZARDOUS ENVIRONMENTAL CONDITION CREATED BY CMAR OR BY ANYONE FOR WHOM CMAR IS RESPONSIBLE. NOTHING IN THIS PARAGRAPH 4.06.H SHALL OBLIGATE CMAR TO INDEMNIFY ANY INDIVIDUAL OR ENTITY FROM AND AGAINST THE CONSEQUENCES OF THAT INDIVIDUAL'S OR ENTITY'S OWN NEGLIGENCE.

- I. The provisions of Paragraphs 4.02, 4.03, and 4.04 do not apply to a Hazardous Environmental Condition uncovered or revealed at the Site.

ARTICLE 5 – BONDS AND INSURANCE

5.01 *Performance, Payment, and Other Bonds*

- A. Contractor shall furnish performance and payment bonds, each in an amount at least equal to the Contract Price as security for the faithful performance and payment of all of Contractor's obligations under the Contract Documents. These bonds shall remain in effect until one year after the date when final payment becomes due or until completion of the correction period specified in Paragraph 13.07, whichever is later, except as provided otherwise by Laws or Regulations or by the Contract Documents. Contractor shall also furnish such other bonds as are required by the Contract Documents.
- B. All bonds shall be in the form prescribed by the Contract Documents except as provided otherwise by Laws or Regulations, and shall be executed by such sureties as are named in the list of "Companies Holding Certificates of Authority as Acceptable Sureties on Federal Bonds and as Acceptable Reinsuring Companies" as published in Circular 570 (amended) by the Financial Management Service, Surety Bond Branch, U.S. Department of the Treasury. All bonds signed by an agent or attorney-in-fact must be accompanied by a certified copy of that individual's authority to bind the surety. The evidence of authority shall show that it is effective on the date the agent or attorney-in-fact signed each bond.
- C. If the surety on any bond furnished by Contractor is declared bankrupt or becomes insolvent or its right to do business is terminated in any state where any part of the Project is located or it ceases to meet the requirements of Paragraph 5.01.B, Contractor shall promptly notify Owner and Engineer and shall, within 20 days after the event giving rise to such notification, provide another bond and surety, both of which shall comply with the requirements of Paragraphs 5.01.B and 5.02. Failure of the CMAR to provide a satisfactory replacement bond may be considered an event of default under Article 15, Paragraph 15.02.
- D. CMAR or surety on behalf of CMAR shall promptly notify the Owner of all claims filed against the Payment Bond. When a claimant has satisfied the conditions prescribed by Texas Government

Code 2253, the CMAR or surety on behalf of CMAR shall, with reasonable promptness, notify the claimant and Owner of the amounts that are undisputed and the basis for challenging any amounts that are disputed, including, but not limited to, the lack of substantiating documentation to support the claim as to entitlement or amount, and the CMAR or surety on behalf of CMAR shall, with reasonable promptness, pay or make arrangements for payment of any undisputed amount; provided, however, that the failure of the CMAR or surety on behalf of CMAR to timely discharge its obligations under this paragraph or to dispute or identify any specific defense to all or any part of a claim shall not be deemed to be an admission of liability by the CMAR or surety as to such claim or otherwise constitute a waiver of the CMAR's or surety's defenses to, or right to dispute, such claim.

- E. Owner shall not be liable for payment of any costs or expenses of any claimant under Payment Bonds, and shall have no obligations to make payments to, give notices on behalf of, or otherwise have obligations to claimants under Payment Bonds.

5.02 *Licensed Sureties and Insurers*

- A. All bonds and insurance required by the Contract Documents to be purchased and maintained by Owner or Contractor shall be obtained from surety or insurance companies that are duly licensed or authorized in the jurisdiction in which the Project is located to issue bonds or insurance policies for the limits and coverages so required. Such surety and insurance companies shall also meet such additional requirements and qualifications as may be provided in the Supplementary Conditions.
- B. Sureties providing performance, payment and other bonds shall have an A.M. Best Company Rating of A-VIII or better. Insurance companies providing insurance required by Contract Documents shall have an A.M. Best Company Rating of A-VIII or better.

5.03 *Certificates of Insurance*

- A. Contractor shall deliver to Owner, with copies to each additional insured and loss payee identified in the Supplementary Conditions, certificates of insurance (and other evidence of insurance requested by Owner or any other additional insured) which Contractor is required to purchase and maintain in accordance with Paragraph 5.04.
- ~~B. Owner shall deliver to Contractor, with copies to each additional insured and loss payee identified in the Supplementary Conditions, certificates of insurance (and other evidence of insurance requested by Contractor or any other additional insured) which Owner is required to purchase and maintain.~~
- C. Failure of Owner to demand such certificates or other evidence of Contractor's full compliance with these insurance requirements or failure of Owner to identify a deficiency in compliance from the evidence provided shall not be construed as a waiver of Contractor's obligation to maintain such insurance.
- D. Owner does not represent that insurance coverage and limits established in this Contract necessarily will be adequate to protect Contractor.
- E. The insurance and insurance limits required herein shall not be deemed as a limitation on Contractor's liability under the indemnities granted to Owner in the Contract Documents.

5.04 *Contractor's Insurance*

- A. Contractor shall purchase and maintain such insurance as is appropriate for the Work being performed and as will provide protection from claims set forth below which may arise out of or result from Contractor's performance of the Work and Contractor's other obligations under the Contract Documents, whether it is to be performed by Contractor, any Subcontractor or Supplier, or by anyone directly or indirectly employed by any of them to perform any of the Work, or by anyone for whose acts any of them may be liable:
1. claims under workers' compensation, disability benefits, and other similar employee benefit acts;
 2. claims for damages because of bodily injury, occupational sickness or disease, or death of Contractor's employees;
 3. claims for damages because of bodily injury, sickness or disease, or death of any person other than Contractor's employees;
 4. claims for damages insured by reasonably available personal injury liability coverage which are sustained:
 - a. by any person as a result of an offense directly or indirectly related to the employment of such person by Contractor, or
 - b. by any other person for any other reason;
 5. claims for damages, other than to the Work itself, because of injury to or destruction of tangible property wherever located, including loss of use resulting therefrom; and
 6. claims for damages because of bodily injury or death of any person or property damage arising out of the ownership, maintenance or use of any motor vehicle.
- B. The policies of insurance required by this Paragraph 5.04 shall:
1. with respect to insurance required by Paragraphs 5.04.A.3 through 5.04.A.6 inclusive, be written on an occurrence basis, include as additional insureds (subject to any customary exclusion regarding professional liability) Owner and Engineer, and any other individuals or entities identified in the Supplementary Conditions, all of whom shall be listed as additional insureds, and include coverage for the respective officers, directors, members, partners, employees, agents, consultants, and subcontractors of each and any of all such additional insureds, and the insurance afforded to these additional insureds shall provide primary coverage for all claims covered thereby;
 2. include at least the specific coverages and be written for not less than the limits of liability provided in the Supplementary Conditions or required by Laws or Regulations, whichever is greater;
 3. include contractual liability insurance covering Contractor's indemnity obligations under Paragraphs 6.11 and 6.20;

4. contain a provision or endorsement that the coverage afforded will not be canceled, materially changed or renewal refused until at least 30 days prior written notice has been given to Owner and Contractor and to each other additional insured identified in the Supplementary Conditions to whom a certificate of insurance has been issued (and the certificates of insurance furnished by the Contractor pursuant to Paragraph 5.03 will so provide);
 5. remain in effect at least until final payment and at all times thereafter when Contractor may be correcting, removing, or replacing defective Work in accordance with Paragraph 13.07; and
 6. include completed operations coverage:
 - a. Such insurance shall remain in effect for two years after final payment.
 - b. Contractor shall furnish Owner and each other additional insured identified in the Supplementary Conditions, to whom a certificate of insurance has been issued, evidence satisfactory to Owner and any such additional insured of continuation of such insurance at final payment and one year thereafter.
- C. Worker's Compensation and Employer's Liability Insurance required by Paragraph 5.04.A.1 and 5.04.A.2 is to provide coverage for not less than the following amounts or greater where required by Laws and Regulations.

<u>Workers' Compensation, etc.,</u>	
1) <u>State:</u>	<u>Statutory</u>
2) <u>Applicable Federal (e.g., Longshore)</u>	<u>Statutory</u>
<u>Employers' Liability</u>	
1) <u>Bodily Injury by Accident</u>	<u>\$500,000</u>
2) <u>Bodily Injury by Disease - Each Employee</u>	<u>\$500,000</u>
3) <u>Bodily Injury by Disease - Policy Limit</u>	<u>\$500,000</u>
4) <u>Maritime Coverage Endorsement</u>	
<u>Insurance shall include a waiver of subrogation in favor of the Additional Insured identified in Paragraph 5.04.B.1.</u>	

- D. CMAR's Liability Insurance required by Paragraph 5.04.A.3, through 5.04.A.5 is to provide coverage for not less than the following amounts or greater where required by Laws and Regulations:

<u>Insurance for Claims of Damages</u>	
1) <u>General Aggregate (Except Products - Completed Operations)</u>	<u>\$2,000,000 / Occurrence</u> <u>\$4,000,000 / Aggregate</u> <u>\$31,000,000 Umbrella</u> <u>Policy</u>
2) <u>Products - Completed Operations Aggregate</u>	<u>\$2,000,000 / Occurrence</u>

	<u>\$4,000,000 / Aggregate \$31,000,000 Umbrella Policy</u>
<u>3) Personal and Advertising Injury (One Person/Organization)</u>	<u>\$1,000,000</u>
<u>4) Each Occurrence (Bodily Injury and Property Damage)</u>	<u>\$1,000,000</u>
<u>5) Limit Per Person – Medical Expense</u>	<u>\$25,000</u>
<u>6) Personal Injury Liability coverage will include claims arising out of Employment Practices Liability, limited to coverage provided under standard contract.</u>	<u>\$1,000,000</u>
<u>7) Property Damage Liability insurance will provide explosion, collapse and underground coverage where applicable</u>	<u>\$1,000,000</u>
<u>8) Watercraft Liability Policy. Coverage shall apply to all self-propelled vessels</u>	<u>\$1,000,000</u>
<u>9) Excess Liability, Umbrella Form to include coverage of Watercraft Liability. General Aggregate - Each Occurrence</u>	<u>\$1,000,000</u>

CMAR's Liability Insurance shall also include completed operations and product liability coverage, and eliminate the exclusion with respect to property under the care, custody and control of CMAR.

Coverage cannot be contingent on an external cause or risk or limited to property for which the CMAR is legally liable. The CMAR will be solely responsible for any deductible carried under this coverage and claims on materials, supplies, machinery, fixture, and equipment which will be incorporated into the Work while in transit or in storage. This policy will include a waiver of subrogation for those listed as additional insured in these Supplemental Conditions.

E. CMAR's Automobile Liability Insurance required by Paragraph 5.04.A.6 is to provide coverage for not less than the following amounts or greater where required by Laws and Regulations. Automobile Liability Insurance will extend to Hired and Non-Owned Autos.

<u>Bodily Injury:</u>	
<u>1) Each Person</u>	<u>\$1,000,000</u>
<u>2) Each Accident</u>	<u>\$1,000,000</u>
<u>Property Damage:</u>	
<u>1) Each Accident</u>	<u>\$1,000,000</u>
<u>Or</u>	
<u>2) Combined Single Limit (Bodily Injury and Property Damage)</u>	<u>\$1,000,000</u>

F. Additional insured on all insurance policies in accordance with Paragraph 5.04.B.1 include:

North Texas Municipal Water District
Freese and Nichols, Inc.
 Lockwood, Andrews & Newnam, Inc,
 Black & Veatch
 Design engineers for the two segments of
 treated water pipeline

G. CMAR's Contractual Liability Insurance required by Paragraph 5.04.B.3 is to provide coverage for not less than the following amounts or greater where required by Laws and Regulations.

<u>CMAR's Contractual Liability Insurance</u>	
<u>1) General Aggregate</u>	<u>\$1,000,000</u>
<u>2) Each Occurrence (Bodily Injury and Property Damage)</u>	<u>\$1,000,000</u>

5.05 *Owner's Liability Insurance*

~~A. In addition to the insurance required to be provided by Contractor under Paragraph 5.04, Owner, at Owner's option, may purchase and maintain at Owner's expense Owner's own liability insurance as will protect Owner against claims which may arise from operations under the Contract Documents. In addition to the insurance required to be provided by CMAR under Paragraph 5.04, CMAR shall purchase and maintain for Owner, at no additional cost, Owner's Protective Liability insurance naming Owner as the named insured with insurance that will protect said parties against claims which may arise from operations under the Contract Documents. This coverage shall be from the same company that provides CMAR's liability insurance coverage, and in the same minimum amounts. The Engineer and Engineer's consultants are additional insured as their interest may appear including their officers, directors, agents and employees.~~

5.06 *Property Insurance*

~~A. Unless otherwise provided in the Supplementary Conditions, Owner shall purchase and maintain property insurance upon the Work at the Site in the amount of the full replacement cost thereof (subject to such deductible amounts as may be provided in the Supplementary Conditions or required by Laws and Regulations). This insurance shall: CMAR shall purchase and maintain property insurance upon the Work at the Site in the amount of the full replacement cost thereof (subject to deductible amounts as may be provided by the Supplementary Conditions or required by Laws and regulations). The policies of insurance required to be purchased and maintained by CMAR in accordance with this Paragraph 5.06 shall comply with requirements of Paragraph 5.08. This insurance shall:~~

1. include the interests of Owner, Contractor, Subcontractors, and Engineer, and any other individuals or entities identified in the Supplementary Conditions, and the officers, directors, members, partners, employees, agents, consultants, and subcontractors of each and any of them, each of whom is deemed to have an insurable interest and shall be listed as a loss payee;

2. be written on a Builder's Risk "all-risk" policy form that shall at least include insurance for physical loss or damage to the Work, temporary buildings, falsework, and materials and equipment in transit, and shall insure against at least the following perils or causes of loss: fire, lightning, extended coverage, theft, vandalism and malicious mischief, earthquake, collapse, debris removal, demolition occasioned by enforcement of Laws and Regulations, water damage (other than that caused by flood), and such other perils or causes of loss as may be specifically required by the Supplementary Conditions.
 3. include expenses incurred in the repair or replacement of any insured property (including but not limited to fees and charges of engineers and architects);
 4. cover materials and equipment stored at the Site or at another location and in transit for incorporation in the Work from such storage locations that was agreed to in writing by Owner prior to being incorporated in the Work, provided that such materials and equipment have been included in an Application for Payment recommended by Engineer;
 5. allow for partial utilization of the Work by Owner;
 6. include testing and startup; and
 7. be maintained in effect until final payment is made unless otherwise agreed to in writing by Owner, Contractor, and Engineer with 30 days written notice to each other loss payee to whom a certificate of insurance has been issued.
- B. ~~Owner shall purchase and maintain such equipment breakdown insurance or additional property insurance as may be required by the Supplementary Conditions or Laws and Regulations which will include the interests of Owner, Contractor, Subcontractors, and Engineer, and any other individuals or entities identified in the Supplementary Conditions, and the officers, directors, members, partners, employees, agents, consultants and subcontractors of each and any of them, each of whom is deemed to have an insurable interest and shall be listed as a loss payee. CMAR shall purchase and maintain such boiler and machinery insurance or additional property insurance as may be required by the Supplementary Conditions or Laws and Regulations which will include the interests of those listed as an insured or listed as an additional insured in Paragraph 5.04.B.1.~~
- C. All the policies of insurance (and the certificates or other evidence thereof) required to be purchased and maintained in accordance with this Paragraph 5.06 will contain a provision or endorsement that the coverage afforded will not be canceled or materially changed or renewal refused until at least 30 days prior written notice has been given to Owner and Contractor and to each other loss payee to whom a certificate of insurance has been issued and will contain waiver provisions in accordance with Paragraph 5.07.
- D. ~~Owner shall not be responsible for purchasing and maintaining any property insurance specified in this Paragraph 5.06 to protect the interests of Contractor, Subcontractors, or others in the Work to the extent of any deductible amounts that are identified in the Supplementary Conditions. The risk of loss within such identified deductible amount will be borne by Contractor, Subcontractors, or others suffering any such loss, and if any of them wishes property insurance coverage within the limits of such amounts, each may purchase and maintain it at the purchaser's own expense.~~

~~E. If Contractor requests in writing that other special insurance be included in the property insurance policies provided under this Paragraph 5.06, Owner shall, if possible, include such insurance, and the cost thereof will be charged to Contractor by appropriate Change Order. Prior to commencement of the Work at the Site, Owner shall in writing advise Contractor whether or not such other insurance has been procured by Owner.~~

5.07 *Waiver of Rights*

- A. Owner and Contractor intend that all policies purchased in accordance with Paragraph 5.06 will protect Owner, Contractor, Subcontractors, and Engineer, and all other individuals or entities identified in the Supplementary Conditions as loss payees (and the officers, directors, members, partners, employees, agents, consultants, and subcontractors of each and any of them) in such policies and will provide primary coverage for all losses and damages caused by the perils or causes of loss covered thereby. All such policies shall contain provisions to the effect that in the event of payment of any loss or damage the insurers will have no rights of recovery against any of the insureds or loss payees thereunder. Owner and Contractor waive all rights against each other and their respective officers, directors, members, partners, employees, agents, consultants and subcontractors of each and any of them for all losses and damages caused by, arising out of or resulting from any of the perils or causes of loss covered by such policies and any other property insurance applicable to the Work; and, in addition, waive all such rights against Subcontractors and Engineer, and all other individuals or entities identified in the Supplementary Conditions as loss payees (and the officers, directors, members, partners, employees, agents, consultants, and subcontractors of each and any of them) under such policies for losses and damages so caused. None of the above waivers shall extend to the rights that any party making such waiver may have to the proceeds of insurance held by Owner as trustee or otherwise payable under any policy so issued.
- ~~B. Owner waives all rights against Contractor, Subcontractors, and Engineer, and the officers, directors, members, partners, employees, agents, consultants and subcontractors of each and any of them for:~~
- ~~1. loss due to business interruption, loss of use, or other consequential loss extending beyond direct physical loss or damage to Owner's property or the Work caused by, arising out of, or resulting from fire or other perils whether or not insured by Owner; and~~
 - ~~2. loss or damage to the completed Project or part thereof caused by, arising out of, or resulting from fire or other insured peril or cause of loss covered by any property insurance maintained on the completed Project or part thereof by Owner during partial utilization pursuant to Paragraph 14.05, after Substantial Completion pursuant to Paragraph 14.04, or after final payment pursuant to Paragraph 14.07.~~
- C. Any insurance policy maintained by Owner covering any loss, damage or consequential loss referred to in Paragraph 5.07.B shall contain provisions to the effect that in the event of payment of any such loss, damage, or consequential loss, the insurers will have no rights of recovery against Contractor, Subcontractors, or Engineer, and the officers, directors, members, partners, employees, agents, consultants and subcontractors of each and any of them.

5.08 *Receipt and Application of Insurance Proceeds*

- A. Any insured loss under the policies of insurance required by Paragraph 5.06 will be adjusted with Owner and made payable to Owner as fiduciary for the loss payees, as their interests may appear, subject to the requirements of any applicable mortgage clause and of Paragraph 5.08.B. Owner shall deposit in a separate account any money so received and shall distribute it in accordance with such agreement as the parties in interest may reach. If no other special agreement is reached, the damaged Work shall be repaired or replaced, the moneys so received applied on account thereof, and the Work and the cost thereof covered by an appropriate Change Order.
- B. Owner as fiduciary shall have power to adjust and settle any loss with the insurers unless one of the parties in interest shall object in writing within 15 days after the occurrence of loss to Owner's exercise of this power. If such objection be made, Owner as fiduciary shall make settlement with the insurers in accordance with such agreement as the parties in interest may reach. If no such agreement among the parties in interest is reached, Owner as fiduciary shall adjust and settle the loss with the insurers and, if required in writing by any party in interest, Owner as fiduciary shall give bond for the proper performance of such duties.

5.09 *Acceptance of Bonds and Insurance; Option to Replace*

- A. If either Owner or Contractor has any objection to the coverage afforded by or other provisions of the bonds or insurance required to be purchased and maintained by the other party in accordance with Article 5 on the basis of non-conformance with the Contract Documents, the objecting party shall so notify the other party in writing within 10 days after receipt of the certificates (or other evidence requested) required by Paragraph 2.01.B. Owner and Contractor shall each provide to the other such additional information in respect of insurance provided as the other may reasonably request. If either party does not purchase or maintain all of the bonds and insurance required of such party by the Contract Documents, such party shall notify the other party in writing of such failure to purchase prior to the start of the Work, or of such failure to maintain prior to any change in the required coverage. Without prejudice to any other right or remedy, the other party may elect to obtain equivalent bonds or insurance to protect such other party's interests at the expense of the party who was required to provide such coverage, and a Change Order shall be issued to adjust the Contract Price accordingly.

5.10 *Partial Utilization, Acknowledgment of Property Insurer*

- A. If Owner finds it necessary to occupy or use a portion or portions of the Work prior to Substantial Completion of all the Work as provided in Paragraph 14.05, no such use or occupancy shall commence before the insurers providing the property insurance pursuant to Paragraph 5.06 have acknowledged notice thereof and in writing effected any changes in coverage necessitated thereby. The insurers providing the property insurance shall consent by endorsement on the policy or policies, but the property insurance shall not be canceled or permitted to lapse on account of any such partial use or occupancy.

5.11 *Owner's Insurance for Project*

- A. Owner shall not be responsible for purchasing and maintaining any insurance to protect the interest of the CMAR, Subcontractors, Engineers, or others in the Work. The stated limits of insurance required are minimum only. CMAR shall determine the limits that are adequate. These limits

may be basic policy limits or any combination of basic limits and umbrella limits. In any event, CMAR is fully responsible for all losses arising out of, resulting from or connected with operations under this Contract whether or not said losses are covered by insurance. The acceptance of certificates or other evidence of insurance by the Owner, Engineer, and/or others listed as additional insured in Paragraph 5.04.B.1 that in any respect do not comply with the Contract requirements does not release the CMAR from compliance herewith.

ARTICLE 6 – CONTRACTOR’S RESPONSIBILITIES

6.01 *Supervision and Superintendence*

- A. Contractor shall supervise, inspect, and direct the Work competently and efficiently, devoting such attention thereto and applying such skills and expertise as may be necessary to perform the Work in accordance with the Contract Documents. Contractor shall be solely responsible for the means, methods, techniques, sequences, and procedures of construction. Contractor shall not be responsible for the negligence of Owner or Engineer in the design or specification of a specific means, method, technique, sequence, or procedure of construction which is shown or indicated in and expressly required by the Contract Documents and properly executed by the CMAR.
- B. At all times during the progress of the Work, Contractor shall assign a competent resident superintendent who shall not be replaced without written notice to Owner and Engineer except under extraordinary circumstances.

6.02 *Labor; Working Hours*

- A. Contractor shall provide competent, suitably qualified personnel to survey and lay out the Work and perform construction as required by the Contract Documents. Contractor shall at all times maintain good discipline and order at the Site.
- B. ~~Except as otherwise required for the safety or protection of persons or the Work or property at the Site or adjacent thereto, and except as otherwise stated in the Contract Documents, all Work at the Site shall be performed during regular working hours. Contractor will not permit the performance of Work on a Saturday, Sunday, or any legal holiday without Owner’s written consent (which will not be unreasonably withheld) given after prior written notice to Engineer.~~ Except as otherwise required for the safety or protection of persons or the Work or property at the Site or adjacent thereto, and except as otherwise stated in the Contract Documents, no Work shall be performed at the Site between 6:00 p.m. and 7:00 a.m. CMAR will not permit the performance of Work on a Saturday, Sunday, or any District holiday. Work performed on the Site between 6:00 p.m. and 7:00 a.m. and Work performed on Saturday, Sunday or any District holiday will be allowed only with the Owner’s written consent, which shall not be unreasonably withheld. Should CMAR desire to Work on these days, he shall contact the Owner, in writing, for approval at least 48 hours in advance. Emergency Work may be done without prior permission. Tie-ins and connections to existing facilities will be made at time authorized by the Owner.

6.03 *Services, Materials, and Equipment*

- A. Unless otherwise specified in the Contract Documents, Contractor shall provide and assume full responsibility for all services, materials, equipment, labor, transportation, construction equipment and machinery, tools, appliances, fuel, power, light, heat, telephone, water, sanitary facilities, temporary facilities, and all other facilities and incidentals necessary for the performance, testing, start-up, and completion of the Work.
- B. All materials and equipment incorporated into the Work shall be as specified or, if not specified, shall be of good quality and new, except as otherwise provided in the Contract Documents. All special warranties and guarantees required by the Specifications shall expressly run to the benefit of Owner. If required by Engineer, Contractor shall furnish satisfactory evidence (including reports of required tests) as to the source, kind, and quality of materials and equipment.
- C. All materials and equipment shall be stored, applied, installed, connected, erected, protected, used, cleaned, and conditioned in accordance with instructions of the applicable Supplier, except as otherwise may be provided in the Contract Documents.

6.04 *Progress Schedule*

- A. Contractor shall adhere to the Progress Schedule established in accordance with Paragraph 2.07 as it may be adjusted from time to time as provided below.
 - 1. Contractor shall submit to Engineer for acceptance (to the extent indicated in Paragraph 2.07) proposed adjustments in the Progress Schedule that will not result in changing the Contract Times. Such adjustments will comply with any provisions of the General Requirements applicable thereto.
 - 2. Proposed adjustments in the Progress Schedule that will change the Contract Times shall be submitted in accordance with the requirements of Article 12. Adjustments in Contract Times may only be made by a Change Order.

6.05 *Substitutes and "Or-Equals"*

- A. ~~Whenever an item of material or equipment is specified or described in the Contract Documents by using the name of a proprietary item or the name of a particular Supplier, the specification or description is intended to establish the type, function, appearance, and quality required. Unless the specification or description contains or is followed by words reading that no like, equivalent, or "or equal" item or no substitution is permitted, other items of material or equipment or material or equipment of other Suppliers may be submitted to Engineer for review under the circumstances described below. Where equipment and products are specified by name, no substitutes or "or-equal" will be considered or approved unless the term "or-equal" is included in the individual Specification. If substitutes or "or equals" are specifically permitted for consideration by the individual Specifications, they must be submitted and will be reviewed and evaluated in accordance with the provisions established in Paragraph 6.05 and in the General Requirements of the Specifications.~~
 - 1. *"Or-Equal" Items:* If in Engineer's sole discretion an item of material or equipment proposed by Contractor is functionally equal to that named and sufficiently similar so that no change in

related Work will be required, it may be considered by Engineer as an “or-equal” item, in which case review and approval of the proposed item may, in Engineer’s sole discretion, be accomplished without compliance with some or all of the requirements for approval of proposed substitute items. For the purposes of this Paragraph 6.05.A.1, a proposed item of material or equipment will be considered functionally equal to an item so named if:

- a. in the exercise of reasonable judgment Engineer determines that:
 - 1) it is at least equal in materials of construction, quality, durability, appearance, strength, and design characteristics;
 - 2) it will reliably perform at least equally well the function and achieve the results imposed by the design concept of the completed Project as a functioning whole; and
 - 3) it has a proven record of performance and availability of responsive service.
- b. Contractor certifies that, if approved and incorporated into the Work:
 - 1) there will be no increase in cost to the Owner or increase in Contract Times; and
 - 2) it will conform substantially to the detailed requirements of the item named in the Contract Documents.

2. *Substitute Items:*

- a. If in Engineer’s sole discretion an item of material or equipment proposed by Contractor does not qualify as an “or-equal” item under Paragraph 6.05.A.1, it will be considered a proposed substitute item.
- b. Contractor shall submit sufficient information as provided below to allow Engineer to determine if the item of material or equipment proposed is essentially equivalent to that named and an acceptable substitute therefor. Requests for review of proposed substitute items of material or equipment will not be accepted by Engineer from anyone other than Contractor.
- c. The requirements for review by Engineer will be as set forth in Paragraph 6.05.A.2.d, as supplemented by the General Requirements, and as Engineer may decide is appropriate under the circumstances.
- d. Contractor shall make written application to Engineer for review of a proposed substitute item of material or equipment that Contractor seeks to furnish or use. The application:
 - 1) shall certify that the proposed substitute item will:
 - a) perform adequately the functions and achieve the results called for by the general design,
 - b) be similar in substance to that specified, and
 - c) be suited to the same use as that specified;

- 2) will state:
 - a) the extent, if any, to which the use of the proposed substitute item will prejudice Contractor's achievement of Substantial Completion on time,
 - b) whether use of the proposed substitute item in the Work will require a change in any of the Contract Documents (or in the provisions of any other direct contract with Owner for other work on the Project) to adapt the design to the proposed substitute item, and
 - c) whether incorporation or use of the proposed substitute item in connection with the Work is subject to payment of any license fee or royalty;
- 3) will identify:
 - a) all variations of the proposed substitute item from that specified, and
 - b) available engineering, sales, maintenance, repair, and replacement services; and
- 4) shall contain an itemized estimate of all costs or credits that will result directly or indirectly from use of such substitute item, including costs of redesign and claims of other contractors affected by any resulting change.

B. *Substitute Construction Methods or Procedures:* If a specific means, method, technique, sequence, or procedure of construction is expressly required by the Contract Documents, Contractor may furnish or utilize a substitute means, method, technique, sequence, or procedure of construction approved by Engineer. Contractor shall submit sufficient information to allow Engineer, in Engineer's sole discretion, to determine that the substitute proposed is equivalent to that expressly called for by the Contract Documents. The requirements for review by Engineer will be similar to those provided in Paragraph 6.05.A.2.

C. *Engineer's Evaluation:* Engineer will be allowed a reasonable time within which to evaluate each proposal or submittal made pursuant to Paragraphs 6.05.A and 6.05.B. Engineer may require Contractor to furnish additional data about the proposed substitute item. Engineer will be the sole judge of acceptability. ~~No "or-equal" or substitute will be ordered, installed or utilized until Engineer's review is complete, which will be evidenced by a Change Order in the case of a substitute and an approved Shop Drawing for an "or-equal."~~ No "or-equal" or substitute will be ordered, installed or utilized until Engineer's review is complete, which will be evidenced by either a Change Order or Field Order. Engineer will advise Contractor in writing of any negative determination.

D. *Special Guarantee:* Owner may require Contractor to furnish at Contractor's expense a special performance guarantee or other surety with respect to any substitute.

E. *Engineer's Cost Reimbursement:* Engineer will record Engineer's costs in evaluating a substitute or "or-equal" proposed or submitted by Contractor pursuant to Paragraphs 6.05.A.2 and 6.05.B. Whether or not Engineer approves a substitute or "or-equal" so proposed or submitted by Contractor, Contractor shall reimburse Owner for the reasonable charges of Engineer for evaluating each such proposed substitute or "or-equal". Contractor shall also reimburse Owner for

the reasonable charges of Engineer for making changes in the Contract Documents (or in the provisions of any other direct contract with Owner) resulting from the acceptance of each proposed substitute or “or-equal”.

- F. *Contractor’s Expense*: Contractor shall provide all data in support of any proposed substitute or “or-equal” at Contractor’s expense.

6.06 *Concerning Subcontractors, Suppliers, and Others*

- A. Contractor shall not employ any Subcontractor, Supplier, or other individual or entity (including those acceptable to Owner as indicated in Paragraph 6.06.B), whether initially or as a replacement, against whom Owner may have reasonable objection. Contractor shall not be required to employ any Subcontractor, Supplier, or other individual or entity to furnish or perform any of the Work against whom Contractor has reasonable objection.
- B. If the ~~Supplementary Conditions~~ Contract Documents require the identity of certain Subcontractors, Suppliers, or other individuals or entities to be submitted to Owner in advance for acceptance by Owner by a specified date prior to the Effective Date of the Agreement, and if Contractor has submitted a list thereof in accordance with the ~~Supplementary Conditions~~ Contract Documents, Owner’s acceptance (either in writing or by failing to make written objection thereto by the date indicated for acceptance or objection in the Bidding Documents or the Contract Documents) of any such Subcontractor, Supplier, or other individual or entity so identified may be revoked on the basis of reasonable objection after due investigation. Contractor shall submit an acceptable replacement for the rejected Subcontractor, Supplier, or other individual or entity, and the Contract Price will be adjusted by the difference in the cost occasioned by such replacement, and an appropriate Change Order will be issued. No acceptance by Owner of any such Subcontractor, Supplier, or other individual or entity, whether initially or as a replacement, shall constitute a waiver of any right of Owner or Engineer to reject defective Work.
- C. Contractor shall be fully responsible to Owner and Engineer for all acts and omissions of the Subcontractors, Suppliers, and other individuals or entities performing or furnishing any of the Work just as Contractor is responsible for Contractor’s own acts and omissions. Nothing in the Contract Documents:
1. shall create for the benefit of any such Subcontractor, Supplier, or other individual or entity any contractual relationship between Owner or Engineer and any such Subcontractor, Supplier or other individual or entity; nor
 2. shall create any obligation on the part of Owner or Engineer to pay or to see to the payment of any moneys due any such Subcontractor, Supplier, or other individual or entity except as may otherwise be required by Laws and Regulations.
- D. Contractor shall be solely responsible for scheduling and coordinating the Work of Subcontractors, Suppliers, and other individuals or entities performing or furnishing any of the Work under a direct or indirect contract with Contractor.
- E. Contractor shall require all Subcontractors, Suppliers, and such other individuals or entities performing or furnishing any of the Work to communicate with Engineer through Contractor.

- F. The divisions and sections of the Specifications and the identifications of any Drawings shall not control Contractor in dividing the Work among Subcontractors or Suppliers or delineating the Work to be performed by any specific trade.
- G. All Work performed for Contractor by a Subcontractor or Supplier will be pursuant to an appropriate agreement between Contractor and the Subcontractor or Supplier which specifically binds the Subcontractor or Supplier to the applicable terms and conditions of the Contract Documents for the benefit of Owner and Engineer. Whenever any such agreement is with a Subcontractor or Supplier who is listed as a loss payee on the property insurance provided in Paragraph 5.06, the agreement between the Contractor and the Subcontractor or Supplier will contain provisions whereby the Subcontractor or Supplier waives all rights against Owner, Contractor, Engineer, and all other individuals or entities identified in the Supplementary Conditions to be listed as insureds or loss payees (and the officers, directors, members, partners, employees, agents, consultants, and subcontractors of each and any of them) for all losses and damages caused by, arising out of, relating to, or resulting from any of the perils or causes of loss covered by such policies and any other property insurance applicable to the Work. If the insurers on any such policies require separate waiver forms to be signed by any Subcontractor or Supplier, Contractor will obtain the same.
- H. Owner or Engineer may furnish to any such Subcontractor, Supplier, or other person or organization, to the extent practicable, information about amounts paid to CMAR in accordance with CMAR's Application for Payment on account of the particular Subcontractor's, Supplier's, other person's or other organization's Work.

6.07 *Patent Fees and Royalties*

- A. Contractor shall pay all license fees and royalties and assume all costs incident to the use in the performance of the Work or the incorporation in the Work of any invention, design, process, product, or device which is the subject of patent rights or copyrights held by others. If a particular invention, design, process, product, or device is specified in the Contract Documents for use in the performance of the Work and if, to the actual knowledge of Owner or Engineer, its use is subject to patent rights or copyrights calling for the payment of any license fee or royalty to others, the existence of such rights shall be disclosed by Owner in the Contract Documents.
- B. ~~To the fullest extent permitted by Laws and Regulations, Owner shall indemnify and hold harmless Contractor, and its officers, directors, members, partners, employees, agents, consultants, and subcontractors from and against all claims, costs, losses, and damages (including but not limited to all fees and charges of engineers, architects, attorneys, and other professionals, and all court or arbitration or other dispute resolution costs) arising out of or relating to any infringement of patent rights or copyrights incident to the use in the performance of the Work or resulting from the incorporation in the Work of any invention, design, process, product, or device specified in the Contract Documents, but not identified as being subject to payment of any license fee or royalty to others required by patent rights or copyrights.~~ **TO THE FULLEST EXTENT PERMITTED BY LAWS AND REGULATIONS, OWNER SHALL INDEMNIFY AND HOLD HARMLESS CMAR, AND ITS OFFICERS, DIRECTORS, MEMBERS, PARTNERS, EMPLOYEES, AGENTS, CONSULTANTS, AND SUBCONTRACTORS FROM AND AGAINST ALL CLAIMS, COSTS, LOSSES, AND DAMAGES (INCLUDING BUT NOT LIMITED TO ALL FEES AND CHARGES OF ENGINEERS, ARCHITECTS, ATTORNEYS, AND OTHER PROFESSIONALS, AND ALL COURT OR ARBITRATION OR OTHER**

DISPUTE RESOLUTION COSTS) ARISING OUT OF OR RELATING TO ANY INFRINGEMENT OF PATENT RIGHTS OR COPYRIGHTS INCIDENT TO THE USE IN THE PERFORMANCE OF THE WORK OR RESULTING FROM THE INCORPORATION IN THE WORK OF ANY INVENTION, DESIGN, PROCESS, PRODUCT, OR DEVICE SPECIFIED IN THE CONTRACT DOCUMENTS, BUT NOT IDENTIFIED AS BEING SUBJECT TO PAYMENT OF ANY LICENSE FEE OR ROYALTY TO OTHERS REQUIRED BY PATENT RIGHTS OR COPYRIGHTS.

- C. ~~To the fullest extent permitted by Laws and Regulations, Contractor shall indemnify and hold harmless Owner and Engineer, and the officers, directors, members, partners, employees, agents, consultants and subcontractors of each and any of them from and against all claims, costs, losses, and damages (including but not limited to all fees and charges of engineers, architects, attorneys, and other professionals and all court or arbitration or other dispute resolution costs) arising out of or relating to any infringement of patent rights or copyrights incident to the use in the performance of the Work or resulting from the incorporation in the Work of any invention, design, process, product, or device not specified in the Contract Documents.~~ TO THE FULLEST EXTENT PERMITTED BY LAWS AND REGULATIONS, CMAR SHALL INDEMNIFY AND HOLD HARMLESS OWNER AND ENGINEER, AND THE OFFICERS, DIRECTORS, MEMBERS, PARTNERS, EMPLOYEES, AGENTS, CONSULTANTS AND SUBCONTRACTORS OF EACH AND ANY OF THEM FROM AND AGAINST ALL CLAIMS, COSTS, LOSSES, AND DAMAGES (INCLUDING BUT NOT LIMITED TO ALL FEES AND CHARGES OF ENGINEERS, ARCHITECTS, ATTORNEYS, AND OTHER PROFESSIONALS AND ALL COURT OR ARBITRATION OR OTHER DISPUTE RESOLUTION COSTS) ARISING OUT OF OR RELATING TO ANY INFRINGEMENT OF PATENT RIGHTS OR COPYRIGHTS INCIDENT TO THE USE IN THE PERFORMANCE OF THE WORK OR RESULTING FROM THE INCORPORATION IN THE WORK OF ANY INVENTION, DESIGN, PROCESS, PRODUCT, OR DEVICE NOT SPECIFIED IN THE CONTRACT DOCUMENTS.

6.08 *Permits*

- A. Unless otherwise provided in the Supplementary Conditions, Contractor shall obtain and pay for all construction permits and licenses. Owner shall assist Contractor, when necessary, in obtaining such permits and licenses. Contractor shall pay all governmental charges and inspection fees necessary for the prosecution of the Work which are applicable at the time of opening of Bids, or, if there are no Bids, on the Effective Date of the Agreement. Owner shall pay all charges of utility owners for connections for providing permanent service to the Work.

6.09 *Laws and Regulations*

- A. Contractor shall give all notices required by and shall comply with all Laws and Regulations applicable to the performance of the Work. Except where otherwise expressly required by applicable Laws and Regulations, neither Owner nor Engineer shall be responsible for monitoring Contractor's compliance with any Laws or Regulations.
- B. ~~If Contractor performs any Work knowing or having reason to know that it is contrary to Laws or Regulations, Contractor shall bear all claims, costs, losses, and damages (including but not limited to all fees and charges of engineers, architects, attorneys, and other professionals and all court or arbitration or other dispute resolution costs) arising out of or relating to such Work. However, it shall not be Contractor's responsibility to make certain that the Specifications and Drawings are in accordance with Laws and Regulations, but this shall not relieve Contractor of Contractor's obligations under Paragraph 3.03. If CMAR performs any Work that it is contrary to Laws or~~

Regulations, CMAR shall bear all claims, costs, losses, and damages (including but not limited to all fees and charges of engineers, architects, attorneys, and other professionals and all court or arbitration or other dispute resolution costs) arising out of or relating to such Work.

- C. Changes in Laws or Regulations not known at the time of opening of Bids (or, on the Effective Date of the Agreement if there were no Bids) having an effect on the cost or time of performance of the Work shall be the subject of an adjustment in Contract Price or Contract Times. If Owner and Contractor are unable to agree on entitlement to or on the amount or extent, if any, of any such adjustment, a Claim may be made therefor as provided in Paragraph 10.05.
- D. All Bidders are required to complete and submit with their Bid the Vendor Compliance to State Law form, which follows the Proposal.
- E. Workers Compensation Statement for Building or Construction Projects for Government entities in Texas. Definitions included in 6.09.E pertain only to 6.09.E and are included verbatim as a statutory requirement of the State of Texas.

1. Definitions:

Certificate of coverage ("certificate") - A copy of a certificate of insurance, a certificate of authority to self-insure issued by the commission, or a coverage agreement (TWCC-81, TWCC-82, TWCC-83, or TWCC-84), showing statutory workers' compensation insurance coverage for the person's or entity's employees providing services on a project for the duration of the project.

Duration of the Project - includes the time from the beginning of the Work on the project until the CMAR's/person's Work on the project has been completed and accepted by the governmental entity.

Persons providing services on the Project ("Subcontractor" in 406.096) - includes all persons or entities performing all or part of the services the CMAR has undertaken to perform on the project, regardless of whether that person contracted directly with the CMAR and regardless of whether that person has employees. This includes, without limitation, independent CMARs, Subcontractors, leasing companies, motor carriers, owner-operators, employees of any such entity, or employees of any entity which furnishes persons to provide services on the project. "Services" include, without limitation, providing, hauling, or delivering equipment or materials, or providing labor, transportation, or other service related to a project. "Services" does not include activities unrelated to the project, such as food/beverage vendors, office supply deliveries, and delivery of portable toilets.

- 2. The CMAR shall provide coverage, based on proper reporting of classification codes and payroll amounts and filing of any coverage agreements, which meets the statutory requirements of Texas Labor Code, Section 401.011(44) for all employees of the CMAR providing services on the Project, for the duration of the Project.
- 3. The CMAR must provide a certificate of coverage to the governmental entity prior to being awarded the Contract.

4. If the coverage period shown on the CMAR's current certificate of coverage ends during the duration of the Project, the CMAR must, prior to the end of the coverage period, file a new certificate of coverage with the governmental entity showing that coverage has been extended.
5. The CMAR shall obtain from each person providing services on a project, and provide to the governmental entity:
 - a. a certificate of coverage, prior to that person beginning Work on the project, so the governmental entity will have on file certificates of coverage showing coverage for all persons providing services on the project; and
 - b. no later than 7 days after receipt by the CMAR, a new certificate of coverage showing extension of coverage, if the coverage period shown on the current certificate of coverage ends during the duration of the project.
6. The CMAR shall retain all required certificates of coverage for the duration of the Project and for 1 year thereafter.
7. The CMAR shall notify the governmental entity in writing by certified mail or personal delivery, within 10 days after the CMAR knew or should have known, of any change that materially affects the provision of coverage of any person providing services on the Project.
8. The CMAR shall post on each project site a notice, in the text, form and manner prescribed by the Texas Workers' Compensation Commission, informing all persons providing services on the project that they are required to be covered, and stating how a person may verify coverage and report lack of coverage.
9. The CMAR shall contractually require each person with whom it contracts to provide services on a project, to:
 - a. provide coverage, based on proper reporting of classification codes and payroll amounts and filing of any coverage agreements, which meets the statutory requirements of Texas Labor Code, Section 401.011(44) for all of its employees providing services on the project, for the duration of the project;
 - b. provide to the CMAR, prior to that person beginning Work on the project, a certificate of coverage showing that coverage is being provided for all employees of the person providing services on the project, for the duration of the project;
 - c. provide the CMAR, prior to the end of the coverage period, a new certificate of coverage showing extension of coverage, if the coverage period shown on the current certificate of coverage ends during the duration of the project;
 - d. obtain from each other person with whom it contracts, and provide to the CMAR:
 - 1) a certificate of coverage, prior to the other person beginning Work on the project; and

- 2) a new certificate of coverage showing extension of coverage, prior to the end of the coverage period, if the coverage period shown on the current certificate of coverage ends during the duration of the project;
 - e. retain all required certificates of coverage on file for the duration of the project and for 1 year thereafter;
 - f. notify the governmental entity in writing by certified mail or personal delivery, within 10 days after the person knew or should have known, of any change that materially affects the provision of coverage of any person providing services on the project; and
 - g. contractually require each person with whom it contracts, to perform as required by Paragraphs (1) - (7), with the certificates of coverage to be provided to the person for whom they are providing services.
10. By signing this Contract or providing or causing to be provided a certificate of coverage, the CMAR is representing to the governmental entity that all employees of the CMAR who will provide services on the Project will be covered by workers' compensation coverage for the duration of the Project, that the coverage will be based on proper reporting of classification codes and payroll amounts, and that all coverage agreements will be filed with the appropriate insurance carrier or, in the case of a self-insured, with the commission's Division of Self-Insurance Regulation. Providing false or misleading information may subject the CMAR to administrative penalties, criminal penalties, civil penalties, or other civil actions.
 11. The CMAR's failure to comply with any of these provisions is a breach of Contract by the CMAR which entitles the governmental entity to declare the Contract void if the CMAR does not remedy the breach within 10 days after receipt of notice of breach from the governmental entity.

6.10 *Taxes*

- A. Contractor shall pay all sales, consumer, use, and other similar taxes required to be paid by Contractor in accordance with the Laws and Regulations of the place of the Project which are applicable during the performance of the Work. The Owner qualifies as an exempt agency as defined by the statutes of the State of Texas. The CMAR shall comply with all statutes and rulings of the State Comptroller.

6.11 *Use of Site and Other Areas*

A. *Limitation on Use of Site and Other Areas:*

1. Contractor shall confine construction equipment, the storage of materials and equipment, and the operations of workers to the Site and other areas permitted by Laws and Regulations, and shall not unreasonably encumber the Site and other areas with construction equipment or other materials or equipment. Contractor shall assume full responsibility for any damage to any such land or area, or to the owner or occupant thereof, or of any adjacent land or areas resulting from the performance of the Work.

2. Should any claim be made by any such owner or occupant because of the performance of the Work, Contractor shall promptly settle with such other party by negotiation or otherwise resolve the claim by arbitration or other dispute resolution proceeding or at law.
 3. ~~To the fullest extent permitted by Laws and Regulations, Contractor shall indemnify and hold harmless Owner and Engineer, and the officers, directors, members, partners, employees, agents, consultants and subcontractors of each and any of them from and against all claims, costs, losses, and damages (including but not limited to all fees and charges of engineers, architects, attorneys, and other professionals and all court or arbitration or other dispute resolution costs) arising out of or relating to any claim or action, legal or equitable, brought by any such owner or occupant against Owner, Engineer, or any other party indemnified hereunder to the extent caused by or based upon Contractor's performance of the Work. TO THE FULLEST EXTENT PERMITTED BY LAWS AND REGULATIONS, CMAR SHALL DEFEND, INDEMNIFY AND HOLD HARMLESS OWNER AND ENGINEER, AND THE OFFICERS, DIRECTORS, MEMBERS, PARTNERS, EMPLOYEES, AGENTS, CONSULTANTS AND SUBCONTRACTORS OF EACH AND ANY OF THEM FROM AND AGAINST ALL CLAIMS, COSTS, LOSSES, AND DAMAGES (INCLUDING BUT NOT LIMITED TO ALL FEES AND CHARGES OF ENGINEERS, ARCHITECTS, ATTORNEYS, AND OTHER PROFESSIONALS AND ALL COURT OR ARBITRATION OR OTHER DISPUTE RESOLUTION COSTS) ARISING OUT OF OR RELATING TO ANY CLAIM OR ACTION, LEGAL OR EQUITABLE, BROUGHT BY ANY SUCH OWNER OR OCCUPANT AGAINST OWNER, ENGINEER, OR ANY OTHER PARTY INDEMNIFIED HEREUNDER TO THE EXTENT CAUSED BY OR BASED UPON CMAR'S PERFORMANCE OF THE WORK.~~
- B. *Removal of Debris During Performance of the Work:* During the progress of the Work Contractor shall keep the Site and other areas free from accumulations of waste materials, rubbish, and other debris. Removal and disposal of such waste materials, rubbish, and other debris shall conform to applicable Laws and Regulations.
- C. *Cleaning:* Prior to Substantial Completion of the Work Contractor shall clean the Site and the Work and make it ready for utilization by Owner. At the completion of the Work Contractor shall remove from the Site all tools, appliances, construction equipment and machinery, and surplus materials and shall restore to original condition all property not designated for alteration by the Contract Documents.
- D. *Loading Structures:* Contractor shall not load nor permit any part of any structure to be loaded in any manner that will endanger the structure, nor shall Contractor subject any part of the Work or adjacent property to stresses or pressures that will endanger it.

6.12 *Record Documents*

- A. Contractor shall maintain in a safe place at the Site one record copy of all Drawings, Specifications, Addenda, Change Orders, Work Change Directives, Field Orders, and written interpretations and clarifications in good order and annotated to show changes made during construction. These record documents together with all approved Samples and a counterpart of all approved Shop Drawings will be available to Engineer for reference. Upon completion of the Work, these record documents, Samples, and Shop Drawings will be delivered to Engineer for Owner.

6.13 *Safety and Protection*

- A. Contractor shall be solely responsible for initiating, maintaining and supervising all safety precautions and programs in connection with the Work. Such responsibility does not relieve Subcontractors of their responsibility for the safety of persons or property in the performance of their work, nor for compliance with applicable safety Laws and Regulations. Contractor shall take all necessary precautions for the safety of, and shall provide the necessary protection to prevent damage, injury or loss to:
1. all persons on the Site or who may be affected by the Work;
 2. all the Work and materials and equipment to be incorporated therein, whether in storage on or off the Site; and
 3. other property at the Site or adjacent thereto, including trees, shrubs, lawns, walks, pavements, roadways, structures, utilities, and Underground Facilities not designated for removal, relocation, or replacement in the course of construction.
- B. Contractor shall comply with all applicable Laws and Regulations relating to the safety of persons or property, or to the protection of persons or property from damage, injury, or loss; and shall erect and maintain all necessary safeguards for such safety and protection. Contractor shall notify owners of adjacent property and of Underground Facilities and other utility owners when prosecution of the Work may affect them, and shall cooperate with them in the protection, removal, relocation, and replacement of their property.
- C. Contractor shall comply with the applicable requirements of Owner's safety programs, if any. The Supplementary Conditions identify any Owner's safety programs that are applicable to the Work.
- D. Contractor shall inform Owner and Engineer of the specific requirements of Contractor's safety program with which Owner's and Engineer's employees and representatives must comply while at the Site.
- E. All damage, injury, or loss to any property referred to in Paragraph 6.13.A.2 or 6.13.A.3 caused, directly or indirectly, in whole or in part, by Contractor, any Subcontractor, Supplier, or any other individual or entity directly or indirectly employed by any of them to perform any of the Work, or anyone for whose acts any of them may be liable, shall be remedied by Contractor (except damage or loss attributable to the fault of Drawings or Specifications or to the acts or omissions of Owner or Engineer or anyone employed by any of them, or anyone for whose acts any of them may be liable, and not attributable, directly or indirectly, in whole or in part, to the fault or negligence of Contractor or any Subcontractor, Supplier, or other individual or entity directly or indirectly employed by any of them).
- F. Contractor's duties and responsibilities for safety and for protection of the Work shall continue until such time as all the Work is completed and Engineer has issued a notice to Owner and Contractor in accordance with Paragraph 14.07.B that the Work is acceptable (except as otherwise expressly provided in connection with Substantial Completion). The CMAR's duties and responsibilities for the safety or protection of persons or the Work or property at the Site or adjacent thereto shall be reinstated when any additional efforts are required during the 1 year correction period to correct defects in the Work.

6.14 *Safety Representative*

- A. Contractor shall designate a qualified and experienced safety representative at the Site whose duties and responsibilities shall be the prevention of accidents and the maintaining and supervising of safety precautions and programs.

6.15 *Hazard Communication Programs*

- A. Contractor shall be responsible for coordinating any exchange of material safety data sheets or other hazard communication information required to be made available to or exchanged between or among employers at the Site in accordance with Laws or Regulations.

6.16 *Emergencies*

- A. In emergencies affecting the safety or protection of persons or the Work or property at the Site or adjacent thereto, Contractor is obligated to act to prevent threatened damage, injury, or loss. Contractor shall give Engineer prompt written notice if Contractor believes that any significant changes in the Work or variations from the Contract Documents have been caused thereby or are required as a result thereof. ~~If Engineer determines that a change in the Contract Documents is required because of the action taken by Contractor in response to such an emergency, a Work Change Directive or Change Order will be issued.~~ If Engineer determines that the incident giving rise to the emergency action was not the responsibility of the CMAR and that a change in the Contract Documents is required because of the action taken by CMAR in response to such an emergency, a Change Order, Field Order or Work Change Directive will be issued.

6.17 *Shop Drawings and Samples*

- A. Contractor shall submit Shop Drawings and Samples to Engineer for review and approval in accordance with the accepted Schedule of Submittals (as required by Paragraph 2.07). Each submittal will be identified as Engineer may require.

1. *Shop Drawings:*

- a. Submit number of copies specified in the General Requirements.
- b. Data shown on the Shop Drawings will be complete with respect to quantities, dimensions, specified performance and design criteria, materials, and similar data to show Engineer the services, materials, and equipment Contractor proposes to provide and to enable Engineer to review the information for the limited purposes required by Paragraph 6.17.D.

2. *Samples:*

- a. Submit number of Samples specified in the Specifications.
- b. Clearly identify each Sample as to material, Supplier, pertinent data such as catalog numbers, the use for which intended and other data as Engineer may require to enable Engineer to review the submittal for the limited purposes required by Paragraph 6.17.D.

B. Where a Shop Drawing or Sample is required by the Contract Documents or the Schedule of Submittals, any related Work performed prior to Engineer's review and approval of the pertinent submittal will be at the sole expense and responsibility of Contractor.

C. *Submittal Procedures:*

1. Before submitting each Shop Drawing or Sample, Contractor shall have:
 - a. reviewed and coordinated each Shop Drawing or Sample with other Shop Drawings and Samples and with the requirements of the Work and the Contract Documents;
 - b. determined and verified all field measurements, quantities, dimensions, specified performance and design criteria, installation requirements, materials, catalog numbers, and similar information with respect thereto;
 - c. determined and verified the suitability of all materials offered with respect to the indicated application, fabrication, shipping, handling, storage, assembly, and installation pertaining to the performance of the Work; and
 - d. determined and verified all information relative to Contractor's responsibilities for means, methods, techniques, sequences, and procedures of construction, and safety precautions and programs incident thereto.
2. Each submittal shall bear a stamp or specific written certification that Contractor has satisfied Contractor's obligations under the Contract Documents with respect to Contractor's review and approval of that submittal.
3. ~~With each submittal, Contractor shall give Engineer specific written notice of any variations that the Shop Drawing or Sample may have from the requirements of the Contract Documents. This notice shall be both a written communication separate from the Shop Drawings or Sample submittal; and, in addition, by a specific notation made on each Shop Drawing or Sample submitted to Engineer for review and approval of each such variation.~~ With each submittal, CMAR shall give Engineer specific written notice of any variations that the Shop Drawing or Sample may have from the requirements of the Contract Documents on a Shop Drawing Deviation Request form provided by the Engineer and request that a Field Order or Change Order be issued for each of the specific variations submitted for approval. This notice shall be both a written communication separate from the Shop Drawings or Sample submittal; and, in addition, by a specific notation made on each Shop Drawing or Sample submitted to Engineer for review and approval of each such variation.

D. *Engineer's Review:*

1. Engineer will provide timely review of Shop Drawings and Samples in accordance with the Schedule of Submittals acceptable to Engineer. Engineer's review and approval will be only to determine if the items covered by the submittals will, after installation or incorporation in the Work, conform to the information given in the Contract Documents and be compatible with the design concept of the completed Project as a functioning whole as indicated by the Contract Documents.

2. Engineer's review and approval will not extend to means, methods, techniques, sequences, or procedures of construction (except where a particular means, method, technique, sequence, or procedure of construction is specifically and expressly called for by the Contract Documents) or to safety precautions or programs incident thereto. The review and approval of a separate item as such will not indicate approval of the assembly in which the item functions.
3. ~~Engineer's review and approval shall not relieve Contractor from responsibility for any variation from the requirements of the Contract Documents unless Contractor has complied with the requirements of Paragraph 6.17.C.3 and Engineer has given written approval of each such variation by specific written notation thereof incorporated in or accompanying the Shop Drawing or Sample. Engineer's review and approval shall not relieve Contractor from responsibility for complying with the requirements of Paragraph 6.17.C.1.~~ Engineer's review and approval shall not relieve CMAR from responsibility for any variation from the requirements of the Contract Documents unless CMAR has complied with the requirements of Paragraph 6.17.C.3 and Engineer has given written approval of each such variation issuing a Field Order or Change Order. If the proposed Modification is approved by the Engineer, the submittal will be considered to be in strict compliance with the Contract Documents and it will be reviewed in accordance with the Contract Documents. If the proposed Modification is not approved, the submittal will be returned to the CMAR with appropriate comments. Engineer's review and approval shall not relieve CMAR from responsibility for complying with the requirements of Paragraph 6.17.C.1.

E. *Resubmittal Procedures:*

1. ~~Contractor shall make corrections required by Engineer and shall return the required number of corrected copies of Shop Drawings and submit, as required, new Samples for review and approval. Contractor shall direct specific attention in writing to revisions other than the corrections called for by Engineer on previous submittals.~~ CMAR shall make corrections required by Engineer and shall return the required number of corrected copies of Shop Drawings and submit, as required, new Samples for review and approval. Re-submittals shall reference and respond directly to Engineer's previous comments. Any variations from strict compliance with the Contract Documents will be identified in the same manner as required in Paragraph 6.17.C.3 and will require the same approvals.
- F. CMAR shall furnish required submittals with sufficient information and accuracy in order to obtain required approval of an item with no more than two submittals. Engineer will record Engineer's time for reviewing subsequent submittals of Shop Drawings, samples, or other items requiring approval and CMAR shall reimburse Owner for Engineer's charges for such time.
- G. In the event that CMAR requests a change of a previously approved item, CMAR shall reimburse Owner for Engineer's charges for its review time unless the need for such change is beyond the control of CMAR.

6.18 *Continuing the Work*

- A. Contractor shall carry on the Work and adhere to the Progress Schedule during all disputes or disagreements with Owner. No Work shall be delayed or postponed pending resolution of any disputes or disagreements, except as permitted by Paragraph 15.04 or as Owner and Contractor

may otherwise agree in writing. CMAR assumes and bears responsibility for all costs and time delays associated with any variation from the requirements of the Contract Documents.

6.19 Contractor's General Warranty and Guarantee

- A. Contractor warrants and guarantees to Owner that all Work will be in accordance with the Contract Documents and will not be defective. Engineer and its officers, directors, members, partners, employees, agents, consultants, and subcontractors shall be entitled to rely on representation of Contractor's warranty and guarantee.
- B. Contractor's warranty and guarantee hereunder excludes defects or damage caused by:
1. abuse, modification, or improper maintenance or operation by persons other than Contractor, Subcontractors, Suppliers, or any other individual or entity for whom Contractor is responsible; or
 2. normal wear and tear under normal usage.
- C. Contractor's obligation to perform and complete the Work in accordance with the Contract Documents shall be absolute. None of the following will constitute an acceptance of Work that is not in accordance with the Contract Documents or a release of Contractor's obligation to perform the Work in accordance with the Contract Documents:
1. observations by Engineer;
 2. recommendation by Engineer or payment by Owner of any progress or final payment;
 3. the issuance of a certificate of Substantial Completion by Engineer or any payment related thereto by Owner;
 4. use or occupancy of the Work or any part thereof by Owner;
 5. any review and approval of a Shop Drawing or Sample submittal or the issuance of a notice of acceptability by Engineer;
 6. any inspection, test, or approval by others; or
 7. any correction of defective Work by Owner.

6.20 Indemnification

- A. ~~To the fullest extent permitted by Laws and Regulations, Contractor shall indemnify and hold harmless Owner and Engineer, and the officers, directors, members, partners, employees, agents, consultants and subcontractors of each and any of them from and against all claims, costs, losses, and damages (including but not limited to all fees and charges of engineers, architects, attorneys, and other professionals and all court or arbitration or other dispute resolution costs) arising out of or relating to the performance of the Work, provided that any such claim, cost, loss, or damage is attributable to bodily injury, sickness, disease, or death, or to injury to or destruction of tangible property (other than the Work itself), including the loss of use resulting therefrom but only to the extent caused by any negligent act or omission of Contractor, any Subcontractor, any Supplier, or~~

any individual or entity directly or indirectly employed by any of them to perform any of the Work or anyone for whose acts any of them may be liable. TO THE FULLEST EXTENT PERMITTED BY LAWS AND REGULATIONS, CMAR SHALL DEFEND, INDEMNIFY AND HOLD HARMLESS OWNER AND ENGINEER, AND THE OFFICERS, DIRECTORS, MEMBERS, PARTNERS, EMPLOYEES, AGENTS, CONSULTANTS AND SUBCONTRACTORS OF EACH AND ANY OF THEM FROM AND AGAINST ALL CLAIMS, COSTS, LOSSES, AND DAMAGES (INCLUDING BUT NOT LIMITED TO ALL FEES AND CHARGES OF ENGINEERS, ARCHITECTS, ATTORNEYS, AND OTHER PROFESSIONALS AND ALL COURT OR ARBITRATION OR OTHER DISPUTE RESOLUTION COSTS) ARISING OUT OF OR RELATING TO THE PERFORMANCE OF THE WORK, PROVIDED THAT ANY SUCH CLAIM, COST, LOSS, OR DAMAGE IS ATTRIBUTABLE TO BODILY INJURY, SICKNESS, DISEASE, OR DEATH, OR TO INJURY TO OR DESTRUCTION OF TANGIBLE PROPERTY (OTHER THAN THE WORK ITSELF), INCLUDING THE LOSS OF USE RESULTING THEREFROM BUT ONLY TO THE EXTENT CAUSED BY ANY INTENTIONAL, KNOWING, AND/OR NEGLIGENT ACT OR OMISSION OF CMAR, ANY SUBCONTRACTOR, ANY SUPPLIER, OR ANY INDIVIDUAL OR ENTITY DIRECTLY OR INDIRECTLY EMPLOYED BY ANY OF THEM TO PERFORM ANY OF THE WORK OR ANYONE FOR WHOSE ACTS ANY OF THEM MAY BE LIABLE.

- B. In any and all claims against Owner or Engineer or any of their officers, directors, members, partners, employees, agents, consultants, or subcontractors by any employee (or the survivor or personal representative of such employee) of Contractor, any Subcontractor, any Supplier, or any individual or entity directly or indirectly employed by any of them to perform any of the Work, or anyone for whose acts any of them may be liable, the indemnification obligation under Paragraph 6.20.A shall not be limited in any way by any limitation on the amount or type of damages, compensation, or benefits payable by or for Contractor or any such Subcontractor, Supplier, or other individual or entity under workers' compensation acts, disability benefit acts, or other employee benefit acts.
- ~~C. The indemnification obligations of Contractor under Paragraph 6.20.A shall not extend to the liability of Engineer and Engineer's officers, directors, members, partners, employees, agents, consultants and subcontractors arising out of:~~
- ~~1. the preparation or approval of, or the failure to prepare or approve maps, Drawings, opinions, reports, surveys, Change Orders, designs, or Specifications; or~~
 - ~~2. giving directions or instructions, or failing to give them, if that is the primary cause of the injury or damage.~~

6.21 *Delegation of Professional Design Services*

- A. Contractor will not be required to provide professional design services unless such services are specifically required by the Contract Documents for a portion of the Work or unless such services are required to carry out Contractor's responsibilities for construction means, methods, techniques, sequences and procedures. Contractor shall not be required to provide professional services in violation of applicable law.
- B. If professional design services or certifications by a design professional related to systems, materials or equipment are specifically required of Contractor by the Contract Documents, Owner and Engineer will specify all performance and design criteria that such services must satisfy. Contractor shall cause such services or certifications to be provided by a properly licensed

professional, whose signature and seal shall appear on all drawings, calculations, specifications, certifications, Shop Drawings and other submittals prepared by such professional. Shop Drawings and other submittals related to the Work designed or certified by such professional, if prepared by others, shall bear such professional's written approval when submitted to Engineer.

- C. Owner and Engineer shall be entitled to rely upon the adequacy, accuracy and completeness of the services, certifications or approvals performed by such design professionals, provided Owner and Engineer have specified to Contractor all performance and design criteria that such services must satisfy.
- D. Pursuant to this Paragraph 6.21, Engineer's review and approval of design calculations and design drawings will be only for the limited purpose of checking for conformance with performance and design criteria given and the design concept expressed in the Contract Documents. Engineer's review and approval of Shop Drawings and other submittals (except design calculations and design drawings) will be only for the purpose stated in Paragraph 6.17.D.1.
- E. Contractor shall not be responsible for the adequacy of the performance or design criteria required by the Contract Documents.

6.22 Standardization of Specifications

- A. The Project is intended to be administered similarly across each of the areas of design. With this understanding, Owner has developed master specifications for use by each of the Project's Engineers.
- B. These specifications will include standardized Division 01 specifications as well as other specifications with the understanding that few modifications will be required by the Engineers.
- C. Other specifications will be developed during the design of the Project and to the extent certain specifications can be standardized across one or more of the three areas of design, Owner desires such standardization.
- D. The CMAR shall review the specification documents after Engineer has prepared these documents for use. The CMAR shall make formal recommendations to each Engineer that would retain document standardization of the procedures and requirements.
- E. In the event CMAR cannot secure the agreement of the Engineers regarding the specifications standardization, the CMAR will submit its recommendations to Owner for Owner's determination.

ARTICLE 7 – OTHER WORK AT THE SITE

7.01 *Related Work at Site*

- A. Owner may perform other work related to the Project at the Site with Owner's employees, or through other direct contracts therefor, or have other work performed by utility owners. If such other work is not noted in the Contract Documents, then:
 - 1. written notice thereof will be given to Contractor prior to starting any such other work; and

2. if Owner and Contractor are unable to agree on entitlement to or on the amount or extent, if any, of any adjustment in the Contract Price or Contract Times that should be allowed as a result of such other work, a Claim may be made therefor as provided in Paragraph 10.05.
- B. Contractor shall afford each other contractor who is a party to such a direct contract, each utility owner, and Owner, if Owner is performing other work with Owner's employees, proper and safe access to the Site, provide a reasonable opportunity for the introduction and storage of materials and equipment and the execution of such other work, and properly coordinate the Work with theirs. Contractor shall do all cutting, fitting, and patching of the Work that may be required to properly connect or otherwise make its several parts come together and properly integrate with such other work. Contractor shall not endanger any work of others by cutting, excavating, or otherwise altering such work; provided, however, that Contractor may cut or alter others' work with the written consent of Engineer and the others whose work will be affected. The duties and responsibilities of Contractor under this Paragraph are for the benefit of such utility owners and other contractors to the extent that there are comparable provisions for the benefit of Contractor in said direct contracts between Owner and such utility owners and other contractors.
- C. If the proper execution or results of any part of Contractor's Work depends upon work performed by others under this Article 7, Contractor shall inspect such other work and promptly report to Engineer in writing any delays, defects, or deficiencies in such other work that render it unavailable or unsuitable for the proper execution and results of Contractor's Work. Contractor's failure to so report will constitute an acceptance of such other work as fit and proper for integration with Contractor's Work except for latent defects and deficiencies in such other work.

7.02 *Coordination*

- A. If Owner intends to contract with others for the performance of other work on the Project at the Site, the following will be set forth in Supplementary Conditions:
1. the individual or entity who will have authority and responsibility for coordination of the activities among the various contractors will be identified;
 2. the specific matters to be covered by such authority and responsibility will be itemized; and
 3. the extent of such authority and responsibilities will be provided.
- B. Unless otherwise provided in the Supplementary Conditions, Owner shall have sole authority and responsibility for such coordination.

7.03 *Legal Relationships*

- A. Paragraphs 7.01.A and 7.02 are not applicable for utilities not under the control of Owner.
- ~~B. Each other direct contract of Owner under Paragraph 7.01.A shall provide that the other contractor is liable to Owner and Contractor for the reasonable direct delay and disruption costs incurred by Contractor as a result of the other contractor's wrongful actions or inactions.~~

- C. Contractor shall be liable to Owner and any other contractor under direct contract to Owner for the reasonable direct delay and disruption costs incurred by such other contractor as a result of Contractor's wrongful action or inactions.

7.04 Claims between Contractors

- A. Should CMAR cause damage to the Work or property of any other contractor at the Site, or should any claim arising out of CMAR's performance of the Work at the Site be made by any other contractor against CMAR, Owner, Engineer, or the construction coordinator, then CMAR (without involving Owner, Engineer, or construction coordinator) shall either (1) remedy the damage, (2) agree to compensate the other contractor for remedy of the damage, or (3) remedy the damage and attempt to settle with such other contractor by agreement, or otherwise resolve the dispute by arbitration or at law.
- B. **CMAR SHALL, TO THE FULLEST EXTENT PERMITTED BY LAWS AND REGULATIONS, DEFEND, INDEMNIFY AND HOLD HARMLESS OWNER, ENGINEER, THE CONSTRUCTION COORDINATOR AND THE OFFICERS, DIRECTORS, PARTNERS, EMPLOYEES, AGENTS AND OTHER CONSULTANTS AND SUBCONTRACTORS OF EACH AND ANY OF THEM FROM AND AGAINST ALL CLAIMS, COSTS, LOSSES AND DAMAGES (INCLUDING, BUT NOT LIMITED TO, FEES AND CHARGES OF ENGINEERS, ARCHITECTS, ATTORNEYS, AND OTHER PROFESSIONALS AND COURT AND ARBITRATION COSTS) ARISING DIRECTLY, INDIRECTLY OR CONSEQUENTIALLY OUT OF ANY ACTION, LEGAL OR EQUITABLE, BROUGHT BY ANY OTHER CONTRACTOR AGAINST OWNER, ENGINEER, CONSULTANTS, OR THE CONSTRUCTION COORDINATOR TO THE EXTENT SAID CLAIM IS BASED ON OR ARISES OUT OF CMAR'S PERFORMANCE OF THE WORK. SHOULD ANOTHER CONTRACTOR CAUSE DAMAGE TO THE WORK OR PROPERTY OF CMAR OR SHOULD THE PERFORMANCE OF WORK BY ANY OTHER CONTRACTOR AT THE SITE GIVE RISE TO ANY OTHER CLAIM, CMAR SHALL NOT INSTITUTE ANY ACTION, LEGAL OR EQUITABLE, AGAINST OWNER, ENGINEER, OR THE CONSTRUCTION COORDINATOR OR PERMIT ANY ACTION AGAINST ANY OF THEM TO BE MAINTAINED AND CONTINUED IN ITS NAME OR FOR ITS BENEFIT IN ANY COURT OR BEFORE ANY ARBITER WHICH SEEKS TO IMPOSE LIABILITY ON OR TO RECOVER DAMAGES FROM OWNER, ENGINEER, OR THE CONSTRUCTION COORDINATOR ON ACCOUNT OF ANY SUCH DAMAGE OR CLAIM.**
- C. If CMAR is delayed at any time in performing or furnishing the Work by any act or neglect of Owner or another contractor who is not directly or indirectly under the control of CMAR, and Owner and CMAR are unable to agree as to the extent of any adjustment in Contract Times attributable thereto, CMAR may make a Claim for an extension of times in accordance with Article 12. An extension of the Contract Times shall be CMAR's exclusive remedy with respect to Owner, Engineer, and construction coordinator for any delay, disruption, interference, or hindrance caused by any other contractor – there shall be no adjustment of the Contract Price allowed. This paragraph does not prevent recovery from Owner, Engineer, or construction coordinator for activities that are their respective responsibilities.

ARTICLE 8 – OWNER'S RESPONSIBILITIES

8.01 *Communications to Contractor*

- A. Except as otherwise provided in these General Conditions, Owner shall issue all communications to Contractor through Engineer.

8.02 *Replacement of Engineer*

- A. In case of termination of the employment of Engineer, Owner shall appoint an engineer to whom Contractor makes no reasonable objection, whose status under the Contract Documents shall be that of the former Engineer.

8.03 *Furnish Data*

- A. Owner shall promptly furnish the data required of Owner under the Contract Documents.

8.04 *Pay When Due*

- A. Owner shall make payments to Contractor when they are due as provided in Paragraphs 14.02.C and 14.07.C.

8.05 *Lands and Easements; Reports and Tests*

- A. Owner's duties with respect to providing lands and easements and providing engineering surveys to establish reference points are set forth in Paragraphs 4.01 and 4.05. Paragraph 4.02 refers to Owner's identifying and making available to Contractor copies of reports of explorations and tests of subsurface conditions and drawings of physical conditions relating to existing surface or subsurface structures at the Site.

8.06 *Insurance*

- A. Owner's responsibilities, if any, with respect to purchasing and maintaining liability and property insurance are set forth in Article 5.

8.07 *Change Orders*

- A. Owner is obligated to execute Change Orders as indicated in Paragraph 10.03.

8.08 *Inspections, Tests, and Approvals*

- A. Owner's responsibility with respect to certain inspections, tests, and approvals is set forth in Paragraph 13.03.B.

8.09 *Limitations on Owner's Responsibilities*

- A. The Owner shall not supervise, direct, or have control or authority over, nor be responsible for, Contractor's means, methods, techniques, sequences, or procedures of construction, or the safety precautions and programs incident thereto, or for any failure of Contractor to comply with Laws and Regulations applicable to the performance of the Work. Owner will not be responsible for Contractor's failure to perform the Work in accordance with the Contract Documents.

8.10 *Undisclosed Hazardous Environmental Condition*

- A. Owner's responsibility in respect to an undisclosed Hazardous Environmental Condition is set forth in Paragraph 4.06.

8.11 *Evidence of Financial Arrangements*

- A. Upon request of Contractor, Owner shall furnish Contractor reasonable evidence that financial arrangements have been made to satisfy Owner's obligations under the Contract Documents.

8.12 *Compliance with Safety Program*

- A. While at the Site, Owner's employees and representatives shall comply with the specific applicable requirements of Contractor's safety programs of which Owner has been informed pursuant to Paragraph 6.13.D.

ARTICLE 9 – ENGINEER'S STATUS DURING CONSTRUCTION

9.01 *Owner's Representative*

- A. Engineer will be Owner's representative during the construction period. The duties and responsibilities and the limitations of authority of Engineer as Owner's representative during construction are set forth in the Contract Documents.

9.02 *Visits to Site*

- A. Engineer will make visits to the Site at intervals appropriate to the various stages of construction as Engineer deems necessary in order to observe as an experienced and qualified design professional the progress that has been made and the quality of the various aspects of Contractor's executed Work. Based on information obtained during such visits and observations, Engineer, for the benefit of Owner, will determine, in general, if the Work is proceeding in accordance with the Contract Documents. Engineer will not be required to make exhaustive or continuous inspections on the Site to check the quality or quantity of the Work. Engineer's efforts will be directed toward providing for Owner a greater degree of confidence that the completed Work will conform generally to the Contract Documents. On the basis of such visits and observations, Engineer will keep Owner informed of the progress of the Work and will endeavor to guard Owner against defective Work.
- B. Engineer's visits and observations are subject to all the limitations on Engineer's authority and responsibility set forth in Paragraph 9.09. Particularly, but without limitation, during or as a result of Engineer's visits or observations of Contractor's Work, Engineer will not supervise, direct, control, or have authority over or be responsible for Contractor's means, methods, techniques, sequences, or procedures of construction, or the safety precautions and programs incident thereto, or for any failure of Contractor to comply with Laws and Regulations applicable to the performance of the Work.

9.03 *Project Representative*

- A. If Owner and Engineer agree, Engineer will furnish a Resident Project Representative to assist Engineer in providing more extensive observation of the Work. The authority and responsibilities of any such Resident Project Representative and assistants will be as provided in the Supplementary Conditions, and limitations on the responsibilities thereof will be as provided in Paragraph 9.09. If Owner designates another representative or agent to represent Owner at the Site who is not Engineer's consultant, agent or employee, the responsibilities and authority and

limitations thereon of such other individual or entity will be as provided in the Supplementary Conditions.

- B. The Resident Project Representative (the "RPR") will be Engineer's employee or agent at the Site, will act as directed by and under the supervision of Engineer, and will confer with Engineer regarding RPR's actions. RPR's dealings in matters pertaining to the Work in general shall be with Engineer and CMAR. RPR's dealings with Subcontractors shall be through or with the full knowledge and approval of CMAR. The RPR shall:
1. Schedules: Review the Progress Schedule, schedule of Shop Drawing and Sample submittals, and Schedule of Values prepared by CMAR and consult with Engineer concerning acceptability.
 2. Conferences and Meetings: Attend meetings with CMAR, such as preconstruction conferences, progress meetings, job conferences and other Project-related meetings, and prepare and circulate copies of minutes thereof.
 3. Liaison:
 - a. Serve as Engineer's liaison with CMAR, working principally through CMAR's authorized representative, assist in providing information regarding the intent of the Contract Documents.
 - b. Assist Engineer in serving as Owner's liaison with CMAR when CMAR's operations affect Owner's on-Site operations.
 - c. Assist in obtaining from Owner additional details or information, when required for proper execution of the Work.
 4. Interpretation of Contract Documents: Report to Engineer when clarifications and interpretations of the Contract Documents are needed and transmit to CMAR clarifications and interpretations as issued by Engineer.
 5. Shop Drawings and Samples:
 - a. Record date of receipt of Samples and approved Shop Drawings.
 - b. Receive Samples which are furnished at the Site by CMAR, and notify Engineer of availability of Samples for examination.
 6. Changes Consider and evaluate CMAR's suggestions for changes in Drawings or Specifications and report such suggestions, together with RPR's recommendations, to Engineer. Transmit to CMAR in writing decisions as issued by Engineer.
 7. Review of Work and Rejection of Defective Work:
 - a. Conduct on-Site observations of CMAR's Work in progress to assist Engineer in determining if the Work is in general proceeding in accordance with the Contract Documents.

- b. Report to Engineer whenever RPR believes that any part of CMAR's Work in progress will not produce a completed Project that conforms generally to the Contract Documents or will imperil the integrity of the design concept of the completed Project as a functioning whole as indicated in the Contract Documents, or has been damaged, or does not meet the requirements of any inspection, test or approval required to be made; and advise Engineer of that part of Work in progress that RPR believes should be corrected or rejected or should be uncovered for observation, or requires special testing, inspection or approval.
8. Inspections, Tests, and System Startups:
 - a. Verify that tests, equipment, and systems startups and operating and maintenance training are conducted in the presence of appropriate Owner's personnel, and that CMAR maintains adequate records thereof.
 - b. Observe, record, and report to Engineer appropriate details relative to the test procedures and systems startups.
9. Records:
 - a. Record names, addresses, fax numbers, e-mail addresses, website locations, and telephone numbers of all, Subcontractors, and major Suppliers of materials and equipment.
 - b. Maintain records for use in preparing Project documentation.
10. Reports:
 - a. Furnish to Engineer periodic reports as required of progress of the Work and of CMAR's compliance with the Progress Schedule and schedule of Shop Drawing and Sample submittals.
 - b. Draft and recommend to Engineer proposed Change Orders, Work Change Directives, and Field Orders. Obtain backup material from CMAR.
 - c. Immediately notify Engineer of the occurrence of any Site accidents, emergencies, acts of God endangering the Work, damage to property by fire or other causes, or the discovery of any Hazardous Environmental Condition.
11. Payment Requests: Review Applications for Payment with CMAR for compliance with the established procedure for their submission and forward with recommendations to Engineer, noting particularly the relationship of the payment requested to the Schedule of Values, Work completed, and materials and equipment delivered at the Site but not incorporated in the Work.
12. Certificates, Operation and Maintenance Manuals: During the course of the Work, verify that materials and equipment certificates, Operation and Maintenance Manuals and other data required by the Specifications to be assembled and furnished by CMAR are applicable to the items actually installed and in accordance with the Contract Documents, and have these documents delivered to Engineer for review and forwarding to Owner prior to payment for that part of the Work.

13. Completion:

- a. Participate in a Substantial Completion inspection, assist in the determination of Substantial Completion and the preparation of lists of items to be completed or corrected.
- b. Participate in a final inspection in the company of Engineer, Owner, and CMAR and prepare a final list of items to be completed and deficiencies to be remedied.
- c. Observe whether all items on the final list have been completed or corrected and make recommendations to Engineer concerning acceptance and issuance of the Notice of Acceptability of the Work.

C. The RPR shall not:

1. Authorize any deviation from the Contract Documents or substitution of materials or equipment (including "or-equal" items).
2. Exceed limitations of Engineer's authority as set forth in the Contract Documents.
3. Undertake any of the responsibilities of CMAR, Subcontractors, Suppliers, or CMAR's superintendent.
4. Advise on, issue directions relative to, or assume control over any aspect of the means, methods, techniques, sequences or procedures of CMAR's Work unless such advice or directions are specifically required by the Contract Documents.
5. Advise on, issue directions regarding, or assume control over safety practices, precautions, and programs in connection with the activities or operations of Owner or CMAR.
6. Participate in specialized field or laboratory tests or inspections conducted off-Site by others except as specifically authorized by Engineer.
7. Accept Shop Drawing or Sample submittals from anyone other than CMAR.
8. Authorize Owner to occupy the Project in whole or in part.

9.04 *Authorized Variations in Work*

- A. Engineer may authorize minor variations in the Work from the requirements of the Contract Documents which do not involve an adjustment in the Contract Price or the Contract Times and are compatible with the design concept of the completed Project as a functioning whole as indicated by the Contract Documents. These may be accomplished by a Field Order and will be binding on Owner and also on Contractor, who shall perform the Work involved promptly. If Owner or Contractor believes that a Field Order justifies an adjustment in the Contract Price or Contract Times, or both, and the parties are unable to agree on entitlement to or on the amount or extent, if any, of any such adjustment, a Claim may be made therefor as provided in Paragraph 10.05. The CMAR shall notify the Engineer in writing prior to beginning any Work addressed in a Field Order if the CMAR does not agree that the Work involved represents no additional cost and/or time change in the Contract Documents.

9.05 *Rejecting Defective Work*

- A. Engineer will have authority to reject Work which Engineer believes to be defective, or that Engineer believes will not produce a completed Project that conforms to the Contract Documents or that will prejudice the integrity of the design concept of the completed Project as a functioning whole as indicated by the Contract Documents. Engineer will also have authority to require special inspection or testing of the Work as provided in Paragraph 13.04, whether or not the Work is fabricated, installed, or completed.

9.06 *Shop Drawings, Change Orders and Payments*

- A. In connection with Engineer's authority, and limitations thereof, as to Shop Drawings and Samples, see Paragraph 6.17.
- B. In connection with Engineer's authority, and limitations thereof, as to design calculations and design drawings submitted in response to a delegation of professional design services, if any, see Paragraph 6.21.
- C. In connection with Engineer's authority as to Change Orders, see Articles 10, 11, and 12.
- D. In connection with Engineer's authority as to Applications for Payment, see Article 14.

9.07 *Determinations for Unit Price Work*

- A. Engineer will determine the actual quantities and classifications of Unit Price Work performed by Contractor. Engineer will review with Contractor the Engineer's preliminary determinations on such matters before rendering a written decision thereon (by recommendation of an Application for Payment or otherwise). Engineer's written decision thereon will be final and binding (except as modified by Engineer to reflect changed factual conditions or more accurate data) upon Owner and Contractor, subject to the provisions of Paragraph 10.05.

9.08 *Decisions on Requirements of Contract Documents and Acceptability of Work*

- A. Engineer will be the initial interpreter of the requirements of the Contract Documents and judge of the acceptability of the Work thereunder. All matters in question and other matters between Owner and Contractor arising prior to the date final payment is due relating to the acceptability of the Work, and the interpretation of the requirements of the Contract Documents pertaining to the performance of the Work, will be referred initially to Engineer in writing within 30 days of the event giving rise to the question.
- B. Engineer will, with reasonable promptness, render a written decision on the issue referred. If Owner or Contractor believes that any such decision entitles them to an adjustment in the Contract Price or Contract Times or both, a Claim may be made under Paragraph 10.05. The date of Engineer's decision shall be the date of the event giving rise to the issues referenced for the purposes of Paragraph 10.05.B.
- C. Engineer's written decision on the issue referred will be final and binding on Owner and Contractor, subject to the provisions of Paragraph 10.05.

- D. When functioning as interpreter and judge under this Paragraph 9.08, Engineer will not show partiality to Owner or Contractor and will not be liable in connection with any interpretation or decision rendered in good faith in such capacity.

9.09 *Limitations on Engineer's Authority and Responsibilities*

- A. Neither Engineer's authority or responsibility under this Article 9 or under any other provision of the Contract Documents nor any decision made by Engineer in good faith either to exercise or not exercise such authority or responsibility or the undertaking, exercise, or performance of any authority or responsibility by Engineer shall create, impose, or give rise to any duty in contract, tort, or otherwise owed by Engineer to Contractor, any Subcontractor, any Supplier, any other individual or entity, or to any surety for or employee or agent of any of them.
- B. Engineer will not supervise, direct, control, or have authority over or be responsible for Contractor's means, methods, techniques, sequences, or procedures of construction, or the safety precautions and programs incident thereto, or for any failure of Contractor to comply with Laws and Regulations applicable to the performance of the Work. Engineer will not be responsible for Contractor's failure to perform the Work in accordance with the Contract Documents.
- C. Engineer will not be responsible for the acts or omissions of Contractor or of any Subcontractor, any Supplier, or of any other individual or entity performing any of the Work.
- D. Engineer's review of the final Application for Payment and accompanying documentation and all maintenance and operating instructions, schedules, guarantees, bonds, certificates of inspection, tests and approvals, and other documentation required to be delivered by Paragraph 14.07.A will only be to determine generally that their content complies with the requirements of, and in the case of certificates of inspections, tests, and approvals that the results certified indicate compliance with, the Contract Documents.
- E. The limitations upon authority and responsibility set forth in this Paragraph 9.09 shall also apply to the Resident Project Representative, if any, and assistants, if any.

9.10 *Compliance with Safety Program*

- A. While at the Site, Engineer's employees and representatives shall comply with the specific applicable requirements of Contractor's safety programs of which Engineer has been informed pursuant to Paragraph 6.13.D.

ARTICLE 10 – CHANGES IN THE WORK; CLAIMS

10.01 *Authorized Changes in the Work*

- A. Without invalidating the Contract and without notice to any surety, Owner may, at any time or from time to time, order additions, deletions, or revisions in the Work by a Change Order, or a Work Change Directive. Upon receipt of any such document, Contractor shall promptly proceed with the Work involved which will be performed under the applicable conditions of the Contract Documents (except as otherwise specifically provided).

- B. If Owner and Contractor are unable to agree on entitlement to, or on the amount or extent, if any, of an adjustment in the Contract Price or Contract Times, or both, that should be allowed as a result of a Work Change Directive, a Claim may be made therefor as provided in Paragraph 10.05.

10.02 *Unauthorized Changes in the Work*

- A. Contractor shall not be entitled to an increase in the Contract Price or an extension of the Contract Times with respect to any work performed that is not required by the Contract Documents as amended, modified, or supplemented as provided in Paragraph 3.04, except in the case of an emergency as provided in Paragraph 6.16 or in the case of uncovering Work as provided in Paragraph 13.04.D.

10.03 *Execution of Change Orders*

- A. Owner and Contractor shall execute appropriate Change Orders recommended by Engineer covering:
1. changes in the Work which are: (i) ordered by Owner pursuant to Paragraph 10.01.A, (ii) required because of acceptance of defective Work under Paragraph 13.08.A or Owner's correction of defective Work under Paragraph 13.09, or (iii) agreed to by the parties;
 2. changes in the Contract Price or Contract Times which are agreed to by the parties, including any undisputed sum or amount of time for Work actually performed in accordance with a Work Change Directive; and
 3. changes in the Contract Price or Contract Times which embody the substance of any written decision rendered by Engineer pursuant to Paragraph 10.05; provided that, in lieu of executing any such Change Order, an appeal may be taken from any such decision in accordance with the provisions of the Contract Documents and applicable Laws and Regulations, but during any such appeal, Contractor shall carry on the Work and adhere to the Progress Schedule as provided in Paragraph 6.18.A.
- B. CMAR assumes and bears responsibility for all costs and time delays associated with any variation from the requirements of the Contract Documents unless the variation is specifically approved by Change Order.

10.04 *Notification to Surety*

- A. If the provisions of any bond require notice to be given to a surety of any change affecting the general scope of the Work or the provisions of the Contract Documents (including, but not limited to, Contract Price or Contract Times), the giving of any such notice will be Contractor's responsibility. The amount of each applicable bond will be adjusted to reflect the effect of any such change.

10.05 *Claims*

- A. *Engineer's Decision Required:* All Claims, except those waived pursuant to Paragraph 14.09, shall be referred to the Engineer for decision. A decision by Engineer shall be required as a condition precedent to any exercise by Owner or Contractor of any rights or remedies either may

otherwise have under the Contract Documents or by Laws and Regulations in respect of such Claims.

- B. *Notice:* Written notice stating the general nature of each Claim shall be delivered by the claimant to Engineer and the other party to the Contract promptly (but in no event later than ~~30~~ 07 days) after the start of the event giving rise thereto. The responsibility to substantiate a Claim shall rest with the party making the Claim. Notice of the amount or extent of the Claim, with supporting data shall be delivered to the Engineer and the other party to the Contract within ~~60~~ 30 days after the start of such event (unless Engineer allows additional time for claimant to submit additional or more accurate data in support of such Claim). A Claim for an adjustment in Contract Price shall be prepared in accordance with the provisions of Paragraph 12.01.B. A Claim for an adjustment in Contract Times shall be prepared in accordance with the provisions of Paragraph 12.02.B. Each Claim shall be accompanied by claimant's written statement that the adjustment claimed is the entire adjustment to which the claimant believes it is entitled as a result of said event. The parties agree and acknowledge that the ability to accurately determine causation, liability, and proper adjustments to the Contract Time and/or Contract Price under these conditions are extremely time sensitive. It is anticipated that a failure by CMAR to provide the aforementioned notice(s) and / or supporting documents within the prescribed deadlines would greatly frustrate if not make impossible the task of accurately analyzing the Claim. As such, CMAR hereby agrees and any failure by CMAR to provide the aforementioned notice(s) and / or supporting documents within the prescribed deadlines shall constitute an unequivocal waiver of said Claim, if any. The opposing party shall submit any response to Engineer and the claimant within ~~30~~ 07 days after receipt of the claimant's last submittal (unless Engineer allows additional time).
- C. *Engineer's Action:* Engineer will review each Claim and, within 30 days after receipt of the last submittal of the claimant or the last submittal of the opposing party, if any, take one of the following actions in writing:
1. deny the Claim in whole or in part;
 2. approve the Claim; or
 3. notify the parties that the Engineer is unable to resolve the Claim if, in the Engineer's sole discretion, it would be inappropriate for the Engineer to do so. For purposes of further resolution of the Claim, such notice shall be deemed a denial.
- D. In the event that Engineer does not take action on a Claim within said 30 days, the Claim shall be deemed denied.
- E. Engineer's written action under Paragraph 10.05.C or denial pursuant to Paragraphs 10.05.C.3 or 10.05.D will be final and binding upon Owner and Contractor, unless Owner or Contractor invoke the dispute resolution procedure set forth in Article 16 within 30 days of such action or denial.
- F. No Claim for an adjustment in Contract Price or Contract Times will be valid if not submitted in accordance with this Paragraph 10.05.

ARTICLE 11 – COST OF THE WORK; ALLOWANCES; UNIT PRICE WORK

11.01 ~~Cost of the Work~~

~~A. *Costs Included:* The term Cost of the Work means the sum of all costs, except those excluded in Paragraph 11.01.B, necessarily incurred and paid by Contractor in the proper performance of the Work. When the value of any Work covered by a Change Order or when a Claim for an adjustment in Contract Price is determined on the basis of Cost of the Work, the costs to be reimbursed to Contractor will be only those additional or incremental costs required because of the change in the Work or because of the event giving rise to the Claim. Except as otherwise may be agreed to in writing by Owner, such costs shall be in amounts no higher than those prevailing in the locality of the Project, shall not include any of the costs itemized in Paragraph 11.01.B, and shall include only the following items:~~

- ~~1. Payroll costs for employees in the direct employ of Contractor in the performance of the Work under schedules of job classifications agreed upon by Owner and Contractor. Such employees shall include, without limitation, superintendents, foremen, and other personnel employed full time on the Work. Payroll costs for employees not employed full time on the Work shall be apportioned on the basis of their time spent on the Work. Payroll costs shall include, but not be limited to, salaries and wages plus the cost of fringe benefits, which shall include social security contributions, unemployment, excise, and payroll taxes, workers' compensation, health and retirement benefits, bonuses, sick leave, vacation and holiday pay applicable thereto. The expenses of performing Work outside of regular working hours, on Saturday, Sunday, or legal holidays, shall be included in the above to the extent authorized by Owner.~~
- ~~2. Cost of all materials and equipment furnished and incorporated in the Work, including costs of transportation and storage thereof, and Suppliers' field services required in connection therewith. All cash discounts shall accrue to Contractor unless Owner deposits funds with Contractor with which to make payments, in which case the cash discounts shall accrue to Owner. All trade discounts, rebates and refunds and returns from sale of surplus materials and equipment shall accrue to Owner, and Contractor shall make provisions so that they may be obtained.~~
- ~~3. Payments made by Contractor to Subcontractors for Work performed by Subcontractors. If required by Owner, Contractor shall obtain competitive bids from subcontractors acceptable to Owner and Contractor and shall deliver such bids to Owner, who will then determine, with the advice of Engineer, which bids, if any, will be acceptable. If any subcontract provides that the Subcontractor is to be paid on the basis of Cost of the Work plus a fee, the Subcontractor's Cost of the Work and fee shall be determined in the same manner as Contractor's Cost of the Work and fee as provided in this Paragraph 11.01.~~
- ~~4. Costs of special consultants (including but not limited to engineers, architects, testing laboratories, surveyors, attorneys, and accountants) employed for services specifically related to the Work.~~
- ~~5. Supplemental costs including the following:
 - ~~a. The proportion of necessary transportation, travel, and subsistence expenses of Contractor's employees incurred in discharge of duties connected with the Work.~~~~

- ~~b. Cost, including transportation and maintenance, of all materials, supplies, equipment, machinery, appliances, office, and temporary facilities at the Site, and hand tools not owned by the workers, which are consumed in the performance of the Work, and cost, less market value, of such items used but not consumed which remain the property of Contractor.~~
- ~~e. Rentals of all construction equipment and machinery, and the parts thereof whether rented from Contractor or others in accordance with rental agreements approved by Owner with the advice of Engineer, and the costs of transportation, loading, unloading, assembly, dismantling, and removal thereof. All such costs shall be in accordance with the terms of said rental agreements. The rental of any such equipment, machinery, or parts shall cease when the use thereof is no longer necessary for the Work.~~
- ~~d. Sales, consumer, use, and other similar taxes related to the Work, and for which Contractor is liable, as imposed by Laws and Regulations.~~
- ~~e. Deposits lost for causes other than negligence of Contractor, any Subcontractor, or anyone directly or indirectly employed by any of them or for whose acts any of them may be liable, and royalty payments and fees for permits and licenses.~~
- ~~f. Losses and damages (and related expenses) caused by damage to the Work, not compensated by insurance or otherwise, sustained by Contractor in connection with the performance of the Work (except losses and damages within the deductible amounts of property insurance established in accordance with Paragraph 5.06.D), provided such losses and damages have resulted from causes other than the negligence of Contractor, any Subcontractor, or anyone directly or indirectly employed by any of them or for whose acts any of them may be liable. Such losses shall include settlements made with the written consent and approval of Owner. No such losses, damages, and expenses shall be included in the Cost of the Work for the purpose of determining Contractor's fee.~~
- ~~g. The cost of utilities, fuel, and sanitary facilities at the Site.~~
- ~~h. Minor expenses such as telegrams, long distance telephone calls, telephone service at the Site, express and courier services, and similar petty cash items in connection with the Work.~~
- ~~i. The costs of premiums for all bonds and insurance Contractor is required by the Contract Documents to purchase and maintain.~~

~~B. *Costs Excluded:* The term Cost of the Work shall not include any of the following items:~~

- ~~1. Payroll costs and other compensation of Contractor's officers, executives, principals (of partnerships and sole proprietorships), general managers, safety managers, engineers, architects, estimators, attorneys, auditors, accountants, purchasing and contracting agents, expeditors, timekeepers, clerks, and other personnel employed by Contractor, whether at the Site or in Contractor's principal or branch office for general administration of the Work and not specifically included in the agreed upon schedule of job classifications referred to in Paragraph 11.01.A.1 or specifically covered by Paragraph 11.01.A.4, all of which are to be considered administrative costs covered by the Contractor's fee.~~

- ~~2. Expenses of Contractor's principal and branch offices other than Contractor's office at the Site.~~
 - ~~3. Any part of Contractor's capital expenses, including interest on Contractor's capital employed for the Work and charges against Contractor for delinquent payments.~~
 - ~~4. Costs due to the negligence of Contractor, any Subcontractor, or anyone directly or indirectly employed by any of them or for whose acts any of them may be liable, including but not limited to, the correction of defective Work, disposal of materials or equipment wrongly supplied, and making good any damage to property.~~
 - ~~5. Other overhead or general expense costs of any kind and the costs of any item not specifically and expressly included in Paragraphs 11.01.A.~~
- ~~C. Contractor's Fee: When all the Work is performed on the basis of cost plus, Contractor's fee shall be determined as set forth in the Agreement. When the value of any Work covered by a Change Order or when a Claim for an adjustment in Contract Price is determined on the basis of Cost of the Work, Contractor's fee shall be determined as set forth in Paragraph 12.01.C.~~
- ~~D. Documentation: Whenever the Cost of the Work for any purpose is to be determined pursuant to Paragraphs 11.01.A and 11.01.B, Contractor will establish and maintain records thereof in accordance with generally accepted accounting practices and submit in a form acceptable to Engineer an itemized cost breakdown together with supporting data.~~

11.01 Cost of the Work

- A. Costs Included: The term Cost of the Work means the sum of:
1. All costs itemized below that are necessarily incurred or paid by the Contractor in the proper performance of the Work:
 - a. Payments made by Contractor to Subcontractors for Work performed by Subcontractors and payments made to Contractor for self-performed work if Contractor is a Bidder and is awarded the Work by Owner in accordance with Chapter 2269 of the Texas Government Code and Article 13 of the Agreement. If required by Owner, Contractor shall obtain competitive Bids from subcontractors acceptable to Owner and Contractor and shall deliver such Bids to Owner, who will then determine, with the advice of Engineer, which Bids, if any, will be acceptable. If any subcontract provides that the Subcontractor is to be paid on the basis of Cost of the Work plus a fee, the Subcontractor's Cost of the Work and fee shall be determined in the same manner as Contractor's Cost of the Work and fee as provided in this Paragraph 11.01. Cost of all materials and equipment furnished and incorporated in the Work, including costs of transportation and storage thereof, and Suppliers' field services required in connection therewith. All cash discounts shall accrue to Contractor unless Owner deposits funds with Contractor with which to make payments, in which case the cash discounts shall accrue to Owner. All trade discounts, rebates and refunds and returns from sale of surplus materials and equipment shall accrue to Owner, and Contractor shall make provisions so that they may be obtained.

- b. Cost of special consultants, including engineers, architects, surveyors, and testing laboratories, employed by Contractor for services specifically related to the Work and the cost of Builder's Risk insurance premiums.
- c. General Conditions: The following costs shall be called "General Conditions." Contractor shall be compensated for these costs on a flat fee basis. The flat fee shall be calculated as the sum of costs described in Articles 11.01(A)(1)(a) and (b), multiplied by that General Conditions percentage set forth in Section 2.02 of the Cost Proposal. The intent is that the CMAR is to be paid General Conditions based upon a constant percentage of the Subcontractor costs, bid-and-self-performed Work costs, materials and equipment costs, and special consultant costs. It is understood that the actual costs incurred by the Contractor for these General Conditions may, in fact, be more or less than that which is calculated with this agreed-upon formula. Both Owner and Contractor agree to be bound by said formula, regardless of the actual General Conditions costs incurred. The following costs are considered General Conditions and shall be paid in accordance with the aforementioned flat fee General Conditions formula:
- 1) All Contractor labor and management costs of any kind.
 - 2) All Contractor transportation costs, travel costs, and subsistence expenses of any kind.
 - 3) The costs of premiums for all bonds and insurance, except for Builder's Risk insurance, Contractor is required by the Contract Documents to purchase and maintain.
 - 4) Cost, including transportation and maintenance, of all materials, supplies, equipment, machinery, appliances, office, and temporary facilities (including those temporary facilities of the owner) at the Site, and hand tools not owned by the workers.
 - 5) Rentals of all construction equipment and machinery, and the parts thereof, as well as the costs of transportation, loading, unloading, assembly, dismantling, and removal thereof.
 - 6) Sales, consumer, use, and other similar taxes related to the Work, and for which Contractor is liable, as imposed by Laws and Regulations.
 - 7) Deposits lost.
 - 8) Losses and damages (and related expenses) caused by damage to the Work.
 - 9) The cost of utilities, fuel, and sanitary facilities at the Site.
 - 10) Minor expenses such as telegrams, long distance telephone calls, telephone service at the Site, express and courier services, and similar petty cash items in connection with the Work.
 - 11) Expenses of Contractor's office at the Site.
 - 12) Any part of Contractor's capital expenses, including interest on Contractor's capital employed for the Work.

13) EXCEPTION: It is understood that it may become necessary to construct long-term housing facilities at or near the Project site. If a Change Order authorizing such Work is approved by Owner, the cost of constructing such temporary long-term housing facilities would fall outside of the definition of General Conditions set forth above, and be governed by the Change Order provisions of the Contract Documents.

B. Documentation: Whenever the Cost of the Work for any purpose is to be determined pursuant to Paragraphs 11.01.A, Contractor will establish and maintain records thereof in accordance with generally accepted accounting practices and submit in a form and at intervals acceptable to Engineer an itemized cost breakdown together with supporting data.

11.02 Allowances

A. It is understood that Contractor has included in the Contract Price all allowances so named in the Contract Documents and shall cause the Work so covered to be performed for such sums and by such persons or entities as may be acceptable to Owner and Engineer.

B. *Cash Allowances:*

1. Contractor agrees that:

- a. the cash allowances include the cost to Contractor (less any applicable trade discounts) of materials and equipment required by the allowances to be delivered at the Site, and all applicable taxes; and
- b. Contractor's costs for unloading and handling on the Site, labor, installation, overhead, profit, and other expenses contemplated for the cash allowances have been included in the Contract Price and not in the allowances, and no demand for additional payment on account of any of the foregoing will be valid.

C. *Contingency Allowance:*

1. Contractor agrees that a contingency allowance, if any, is for the sole use of Owner to cover unanticipated costs.

D. Prior to final payment, an appropriate Change Order will be issued as recommended by Engineer to reflect actual amounts due Contractor on account of Work covered by allowances, and the Contract Price shall be correspondingly adjusted.

11.03 Unit Price Work

A. Where the Contract Documents provide that all or part of the Work is to be Unit Price Work, initially the Contract Price will be deemed to include for all Unit Price Work an amount equal to the sum of the unit price for each separately identified item of Unit Price Work times the estimated quantity of each item as indicated in the Agreement.

B. The estimated quantities of items of Unit Price Work are not guaranteed and are solely for the purpose of comparison of Bids and determining an initial Contract Price. Determinations of the

actual quantities and classifications of Unit Price Work performed by Contractor will be made by Engineer subject to the provisions of Paragraph 9.07.

C. Each unit price will be deemed to include an amount considered by Contractor to be adequate to cover Contractor's overhead and profit for each separately identified item.

~~D. Owner or Contractor may make a Claim for an adjustment in the Contract Price in accordance with Paragraph 10.05 if:~~

- ~~1. the quantity of any item of Unit Price Work performed by Contractor differs materially and significantly from the estimated quantity of such item indicated in the Agreement; and~~
- ~~2. there is no corresponding adjustment with respect to any other item of Work; and~~
- ~~3. Contractor believes that Contractor is entitled to an increase in Contract Price as a result of having incurred additional expense or Owner believes that Owner is entitled to a decrease in Contract Price and the parties are unable to agree as to the amount of any such increase or decrease.~~

D. The unit price of an item of Unit Price Work shall be subject to reevaluation and adjustment under the following conditions:

1. If the total cost of a particular item of Unit Price Work amounts to 20 percent or more of the total Contract Price and the variation in the quantity of that particular item of Unit Price Work performed by the CMAR differs by more than 20 percent from the estimated quantity of such item indicated in the Agreement; and
2. if there is no corresponding adjustment with respect to any other item of Work; and
3. if CMAR believes that CMAR has incurred additional expense as a result thereof; or if Owner believes that the quantity variation entitles Owner to an adjustment in the Unit Price, either the Owner or CMAR may make a claim for an adjustment in the Contract Price in accordance with Article 11 if the parties are unable to agree as to the effect of any such variation in the quantity of the Unit Price Work performed.

ARTICLE 12 – CHANGE OF CONTRACT PRICE; CHANGE OF CONTRACT TIMES

12.01 Change of Contract Price

A. The Contract Price may only be changed by a Change Order. Any Claim for an adjustment in the Contract Price shall be based on written notice submitted by the party making the Claim to the Engineer and the other party to the Contract in accordance with the provisions of Paragraph 10.05.

B. The value of any Work covered by a Change Order or of any Claim for an adjustment in the Contract Price will be determined as follows:

1. where the Work involved is covered by unit prices contained in the Contract Documents, by application of such unit prices to the quantities of the items involved (subject to the provisions of Paragraph 11.03); or

2. where the Work involved is not covered by unit prices contained in the Contract Documents, by a mutually agreed lump sum (which may include an allowance for overhead and profit not necessarily in accordance with Paragraph 12.01.C.2); or
 3. where the Work involved is not covered by unit prices contained in the Contract Documents and agreement to a lump sum is not reached under Paragraph 12.01.B.2, on the basis of the Cost of the Work (determined as provided in Paragraph 11.01) plus a Contractor's fee for overhead and profit (determined as provided in Paragraph 12.01.C).
- C. *Contractor's Fee:* The Contractor's fee for overhead and profit shall be in the same percentage set forth in Article 6.01 of the Agreement ~~as determined as follows:~~
1. ~~a mutually acceptable fixed fee; or~~
 2. ~~if a fixed fee is not agreed upon, then a fee based on the following percentages of the various portions of the Cost of the Work:~~
 - a. ~~for costs incurred under Paragraphs 11.01.A.1 and 11.01.A.2, the Contractor's fee shall be 15 percent;~~
 - b. ~~for costs incurred under Paragraph 11.01.A.3, the Contractor's fee shall be five percent;~~
 - c. ~~where one or more tiers of subcontracts are on the basis of Cost of the Work plus a fee and no fixed fee is agreed upon, the intent of Paragraphs 12.01.C.2.a and 12.01.C.2.b is that the Subcontractor who actually performs the Work, at whatever tier, will be paid a fee of 15 percent of the costs incurred by such Subcontractor under Paragraphs 11.01.A.1 and 11.01.A.2 and that any higher tier Subcontractor and Contractor will each be paid a fee of five percent of the amount paid to the next lower tier Subcontractor;~~
 - d. ~~no fee shall be payable on the basis of costs itemized under Paragraphs 11.01.A.4, 11.01.A.5, and 11.01.B;~~
 - e. ~~the amount of credit to be allowed by Contractor to Owner for any change which results in a net decrease in cost will be the amount of the actual net decrease in cost plus a deduction in Contractor's fee by an amount equal to five percent of such net decrease; and~~
 - f. ~~when both additions and credits are involved in any one change, the adjustment in Contractor's fee shall be computed on the basis of the net change in accordance with Paragraphs 12.01.C.2.a through 12.01.C.2.e, inclusive.~~

12.02 *Change of Contract Times*

- A. The Contract Times may only be changed by a Change Order. Any Claim for an adjustment in the Contract Times shall be based on written notice submitted by the party making the Claim to the Engineer and the other party to the Contract in accordance with the provisions of Paragraph 10.05.
- B. Any adjustment of the Contract Times covered by a Change Order or any Claim for an adjustment in the Contract Times will be determined in accordance with the provisions of this Article 12.

12.03 *Delays*

- A. Where Contractor is prevented from completing any part of the Work within the Contract Times due to delay beyond the control of Contractor, the Contract Times will be extended in an amount equal to the time lost due to such delay if a Claim is made therefor as provided in Paragraph 12.02.A. Delays beyond the control of Contractor shall include, but not be limited to, acts or neglect by Owner, acts or neglect of utility owners or other contractors performing other work as contemplated by Article 7, fires, floods, epidemics, abnormal weather conditions, or acts of God. No time extensions will be allowed for weather conditions for Projects using Calendar Days for the Contract Time. The CMAR agrees to make no Claims for an adjustment in the Contract Price for damage due to delay in the performance of the Contract occasioned by any act or omission to act of the Owner, Engineer, or any of the Engineer's or Owner's agents and/or contractors, and agrees that any such claim shall be fully compensated by an extension of the Contract Time, as set forth in a Change Order, to complete performance of the Work as provided herein.
- ~~B. If Owner, Engineer, or other contractors or utility owners performing other work for Owner as contemplated by Article 7, or anyone for whom Owner is responsible, delays, disrupts, or interferes with the performance or progress of the Work, then Contractor shall be entitled to an equitable adjustment in the Contract Price or the Contract Times, or both. Contractor's entitlement to an adjustment of the Contract Times is conditioned on such adjustment being essential to Contractor's ability to complete the Work within the Contract Times.~~
- C. If Contractor is delayed in the performance or progress of the Work by fire, flood, epidemic, abnormal weather conditions, acts of God, acts or failures to act of utility owners not under the control of Owner, or other causes not the fault of and beyond control of Owner and Contractor, then Contractor shall be entitled to an equitable adjustment in Contract Times, if such adjustment is essential to Contractor's ability to complete the Work within the Contract Times. Such an adjustment shall be Contractor's sole and exclusive remedy for the delays described in this Paragraph 12.03.C. The CMAR agrees to make no Claims for an adjustment in the Contract Price for damage due to delay in the performance of the Work occasioned by fire, flood, epidemic, abnormal weather conditions, acts of God, or other causes not the fault of and beyond control of Owner and Contractor, and agrees that any such claim shall be fully compensated by an extension of the Contract Time, as set forth in a Change Order, to complete performance of the Work as provided herein.
- D. Owner, Engineer, and their officers, directors, members, partners, employees, agents, consultants, or subcontractors shall not be liable to Contractor for any claims, costs, losses, or damages (including but not limited to all fees and charges of engineers, architects, attorneys, and other professionals and all court or arbitration or other dispute resolution costs) sustained by Contractor on or in connection with any other project or anticipated project.
- E. Contractor shall not be entitled to an adjustment in Contract Price or Contract Times for delays within the control of Contractor. Delays attributable to and within the control of a Subcontractor or Supplier shall be deemed to be delays within the control of Contractor.

12.04 *No Damage for Delays*

- A. The CMAR agrees to make no Claim for an adjustment in the Contract Price for damage due to delay in the performance of the Contract occasioned by any act or omission to act of the Owner.

Engineer, or any of the Engineer's or Owner's agents and/or contractors, and agrees that any such claim shall be fully compensated by an extension of the Contract Time, as set forth in a Change Order, to complete performance of the Work as provided herein..

ARTICLE 13 – TESTS AND INSPECTIONS; CORRECTION, REMOVAL OR ACCEPTANCE OF DEFECTIVE WORK

13.01 Notice of Defects

- A. Prompt notice of all defective Work of which Owner or Engineer has actual knowledge will be given to Contractor. Defective Work may be rejected, corrected, or accepted as provided in this Article 13.

13.02 Access to Work

- A. Owner, Engineer, their consultants and other representatives and personnel of Owner, independent testing laboratories, and governmental agencies with jurisdictional interests will have access to the Site and the Work at reasonable times for their observation, inspection, and testing. Contractor shall provide them proper and safe conditions for such access and advise them of Contractor's safety procedures and programs so that they may comply therewith as applicable.

13.03 Tests and Inspections

- A. Contractor shall give Engineer timely notice of readiness of the Work for all required inspections, tests, or approvals and shall cooperate with inspection and testing personnel to facilitate required inspections or tests.

~~B. Owner shall employ and pay for the services of an independent testing laboratory to perform all inspections, tests, or approvals required by the Contract Documents except:~~

- ~~1. for inspections, tests, or approvals covered by Paragraphs 13.03.C and 13.03.D below;~~
- ~~2. that costs incurred in connection with tests or inspections conducted pursuant to Paragraph 13.04.B shall be paid as provided in Paragraph 13.04.C; and~~
- ~~3. as otherwise specifically provided in the Contract Documents.~~

B. CMAR shall employ and pay for the services of an independent testing laboratory to perform all inspections, tests, or approvals required by the Contract Documents. The CMAR is solely responsible for maintaining that the quality of Work is in accordance with the Contract Documents. The CMAR shall be responsible for the notification and scheduling required assuring that a certified technician from the testing laboratory is present during all sampling and testing procedures required in the Contract Documents. The CMAR shall not proceed with Work requiring such testing without the presence of the laboratory's certified technician. The Owner, at his option, may perform additional tests as quality monitoring. Quality monitoring activities of the Owner and Engineer, or failure on the part of the Owner or Engineer to perform tests on Work, in no way relieves the CMAR of the obligation to perform Work and furnish materials conforming to the Contract Documents.

1. CMAR's Responsibilities

- a. Control the quality of Work produced and verify that the Work performed meets the standards of quality established in the Contract Documents.
 1. Inspect and verify conformance of all materials furnished and Work performed, whether by the CMAR, its Subcontractors or its Suppliers.
 2. Provide and pay for the services of a testing laboratory approved by Owner to insure that products proposed for use fully comply with the Contract Documents.
 3. Perform tests as indicated in this and other sections of the Specifications. Schedule the time and sequence of testing with the Owner and Engineer. Testing is to be observed by the Owner, Engineer, or designated representative.
 4. Promptly replace any defective materials and/or Work incorporating defective materials or workmanship.
 5. Provide Certified Test Reports as required by the “Submittal Procedures” Section. Reports are to indicate that materials and construction are in compliance with the Contract Documents.
 6. Assist the Engineer, Owner, and Owner’s testing organization to perform quality monitoring activities.

2. Quality Monitoring Activities by the Owner

- a. Quality Monitoring activities of the Owner and Engineer through their own forces or through contracts with materials testing laboratories and survey crews are for the Owner’s use in monitoring the results of the CMAR’s Work and quality control activities, if deemed necessary by the Owner and Engineer. The Quality Monitoring activities of the Owner do not relieve the CMAR of its responsibility to provide testing in accordance with the requirements of the Contract Documents or to provide materials and Work complying with the Contract Documents.

3. Submittals

- a. Submittals shall be accordance with the “Submittal Procedures” Section, and shall include:
 1. The name of the proposed primary and secondary testing laboratories along with documentation of qualifications, a list of tests that can be performed, and a list of the certified laboratory technicians and the licensed engineers who will be performing the sampling and testing for the Work along with their certifications and licenses.
 2. Test reports per Paragraph 7 “Test Reports” of this Supplementary Condition.

4. Standards

- a. Provide a testing laboratory that complies with the ASTM (American Society of Testing Materials) and/or ACIL (American Council of Independent Laboratories) “Recommended Requirements for Independent Laboratory Qualifications”, or other specified testing organizations.

b. Perform tests listed in the Specifications.

5. Delivery and Storage

a. Handle and protect test specimens of products and construction materials at the construction Site in accordance with ASTM or other applicable testing procedures.

6. Verification Testing

a. Provide verification testing when tests performed by the Owner indicate that materials or the results of construction activities are not in conformance with Contract Documents.

b. Verification testing is to be provided at the CMAR's expense to verify products or Work are in compliance after corrections have been made.

c. Tests must comply with recognized methods or with methods recommended by the Owner's testing laboratory and approved by the Engineer.

7. Test Reports

A. Test reports are to be prepared for all tests.

1. Tests performed by testing laboratories may be submitted on their standard test report forms. These reports must include the following:

a. Name of the Owner, Project title and number, equipment installer and general CMAR.

b. Name of the laboratory, address, and telephone number.

c. Name and signature of the certified laboratory personnel performing the sampling and testing.

d. Date and time of sampling, inspection, and testing.

e. Date the report was issued.

f. Description of the test performed.

g. Weather conditions and temperature at time of test or sampling.

h. Location at the Site or structure where the test was taken.

i. Standard or test procedure used in making the test.

j. A description of the results of the test.

k. Statement of compliance or non-compliance with Contract Documents.

l. Interpretations of test results, if appropriate.

B. Distribute copies of the test reports to:

<u>Recipient</u>	<u>No. of Copies</u>
<u>Owner</u>	<u>2 copies</u>
<u>Resident Project Representative</u>	<u>1 copy</u>

<u>Engineer</u>	<u>1 copy</u>
<u>CMAR</u>	<u>1 copy</u>

8. Non-Conforming Work

- A. CMAR shall promptly correct any Work that is not in compliance with the Contract Documents and shall immediately notify the Owner when the corrective Work will be performed.
- B. Payment for non-conforming Work shall be withheld until such Work is corrected or replaced with Work complying with the Contract Documents.
- C. If Laws or Regulations of any public body having jurisdiction require any Work (or part thereof) specifically to be inspected, tested, or approved by an employee or other representative of such public body, Contractor shall assume full responsibility for arranging and obtaining such inspections, tests, or approvals, pay all costs in connection therewith, and furnish Engineer the required certificates of inspection or approval.
- D. Contractor shall be responsible for arranging and obtaining and shall pay all costs in connection with any inspections, tests, or approvals required for Owner's and Engineer's acceptance of materials or equipment to be incorporated in the Work; or acceptance of materials, mix designs, or equipment submitted for approval prior to Contractor's purchase thereof for incorporation in the Work. Such inspections, tests, or approvals shall be performed by organizations acceptable to Owner and Engineer.
- E. If any Work (or the work of others) that is to be inspected, tested, or approved is covered by Contractor without written concurrence of Engineer, Contractor shall, if requested by Engineer, uncover such Work for observation.
- F. Uncovering Work as provided in Paragraph 13.03.E shall be at Contractor's expense unless Contractor has given Engineer timely notice of Contractor's intention to cover the same and Engineer has not acted with reasonable promptness in response to such notice.

13.04 *Uncovering Work*

- A. If any Work is covered contrary to the written request of Engineer, it must, if requested by Engineer, be uncovered for Engineer's observation and replaced at Contractor's expense.
- B. If Engineer considers it necessary or advisable that covered Work be observed by Engineer or inspected or tested by others, Contractor, at Engineer's request, shall uncover, expose, or otherwise make available for observation, inspection, or testing as Engineer may require, that portion of the Work in question, furnishing all necessary labor, material, and equipment.
- C. If it is found that the uncovered Work is defective, Contractor shall pay all claims, costs, losses, and damages (including but not limited to all fees and charges of engineers, architects, attorneys, and other professionals and all court or arbitration or other dispute resolution costs) arising out of or relating to such uncovering, exposure, observation, inspection, and testing, and of satisfactory replacement or reconstruction (including but not limited to all costs of repair or replacement of work of others); and Owner shall be entitled to an appropriate decrease in the Contract Price. If

the parties are unable to agree as to the amount thereof, Owner may make a Claim therefor as provided in Paragraph 10.05.

- D. If the uncovered Work is not found to be defective, Contractor shall be allowed an increase in the Contract Price or an extension of the Contract Times, or both, directly attributable to such uncovering, exposure, observation, inspection, testing, replacement, and reconstruction. If the parties are unable to agree as to the amount or extent thereof, Contractor may make a Claim therefor as provided in Paragraph 10.05.

13.05 *Owner May Stop the Work*

- A. If the Work is defective, or Contractor fails to supply sufficient skilled workers or suitable materials or equipment, or fails to perform the Work in such a way that the completed Work will conform to the Contract Documents, Owner may order Contractor to stop the Work, or any portion thereof, until the cause for such order has been eliminated; however, this right of Owner to stop the Work shall not give rise to any duty on the part of Owner to exercise this right for the benefit of Contractor, any Subcontractor, any Supplier, any other individual or entity, or any surety for, or employee or agent of any of them.

13.06 *Correction or Removal of Defective Work*

- A. Promptly after receipt of written notice, Contractor shall correct all defective Work, whether or not fabricated, installed, or completed, or, if the Work has been rejected by Engineer, remove it from the Project and replace it with Work that is not defective. Contractor shall pay all claims, costs, losses, and damages (including but not limited to all fees and charges of engineers, architects, attorneys, and other professionals and all court or arbitration or other dispute resolution costs) arising out of or relating to such correction or removal (including but not limited to all costs of repair or replacement of work of others).
- B. When correcting defective Work under the terms of this Paragraph 13.06 or Paragraph 13.07, Contractor shall take no action that would void or otherwise impair Owner's special warranty and guarantee, if any, on said Work.

13.07 *Correction Period*

- A. When early acceptance of a Substantially Completed portion of the Work is accomplished in the manner indicated, the correction period for that portion of the Work shall commence at the time of Substantial Completion of that Work. If within one year after the date of Substantial Completion (or such longer period of time as may be prescribed by the terms of any applicable special guarantee required by the Contract Documents) or by any specific provision of the Contract Documents, any Work is found to be defective, or if the repair of any damages to the land or areas made available for Contractor's use by Owner or permitted by Laws and Regulations as contemplated in Paragraph 6.11.A is found to be defective, Contractor shall promptly, without cost to Owner and in accordance with Owner's written instructions:
1. repair such defective land or areas; or
 2. correct such defective Work; or

3. if the defective Work has been rejected by Owner, remove it from the Project and replace it with Work that is not defective, and
 4. satisfactorily correct or repair or remove and replace any damage to other Work, to the work of others or other land or areas resulting therefrom.
- B. If Contractor does not promptly comply with the terms of Owner's written instructions, or in an emergency where delay would cause serious risk of loss or damage, Owner may have the defective Work corrected or repaired or may have the rejected Work removed and replaced. All claims, costs, losses, and damages (including but not limited to all fees and charges of engineers, architects, attorneys, and other professionals and all court or arbitration or other dispute resolution costs) arising out of or relating to such correction or repair or such removal and replacement (including but not limited to all costs of repair or replacement of work of others) will be paid by Contractor.
- C. In special circumstances where a particular item of equipment is placed in continuous service before Substantial Completion of all the Work, the correction period for that item may start to run from an earlier date if so provided in the Specifications.
- D. Where defective Work (and damage to other Work resulting therefrom) has been corrected or removed and replaced under this Paragraph 13.07, the correction period hereunder with respect to such Work will be extended for an additional period of one year after such correction or removal and replacement has been satisfactorily completed.
- E. Contractor's obligations under this Paragraph 13.07 are in addition to any other obligation or warranty. The provisions of this Paragraph 13.07 shall not be construed as a substitute for, or a waiver of, the provisions of any applicable statute of limitation or repose.

13.08 *Acceptance of Defective Work*

- A. If, instead of requiring correction or removal and replacement of defective Work, Owner (and, prior to Engineer's recommendation of final payment, Engineer) prefers to accept it, Owner may do so. Contractor shall pay all claims, costs, losses, and damages (including but not limited to all fees and charges of engineers, architects, attorneys, and other professionals and all court or arbitration or other dispute resolution costs) attributable to Owner's evaluation of and determination to accept such defective Work (such costs to be approved by Engineer as to reasonableness) and for the diminished value of the Work to the extent not otherwise paid by Contractor pursuant to this sentence. If any such acceptance occurs prior to Engineer's recommendation of final payment, a Change Order will be issued incorporating the necessary revisions in the Contract Documents with respect to the Work, and Owner shall be entitled to an appropriate decrease in the Contract Price, reflecting the diminished value of Work so accepted. If the parties are unable to agree as to the amount thereof, Owner may make a Claim therefor as provided in Paragraph 10.05. If the acceptance occurs after such recommendation, an appropriate amount will be paid by Contractor to Owner.

13.09 *Owner May Correct Defective Work*

- A. If Contractor fails within a reasonable time after written notice from Engineer to correct defective Work, or to remove and replace rejected Work as required by Engineer in accordance with

Paragraph 13.06.A, or if Contractor fails to perform the Work in accordance with the Contract Documents, or if Contractor fails to comply with any other provision of the Contract Documents, Owner may, after seven days written notice to Contractor, correct, or remedy any such deficiency.

- B. In exercising the rights and remedies under this Paragraph 13.09, Owner shall proceed expeditiously. In connection with such corrective or remedial action, Owner may exclude Contractor from all or part of the Site, take possession of all or part of the Work and suspend Contractor's services related thereto, take possession of Contractor's tools, appliances, construction equipment and machinery at the Site, and incorporate in the Work all materials and equipment stored at the Site or for which Owner has paid Contractor but which are stored elsewhere. Contractor shall allow Owner, Owner's representatives, agents and employees, Owner's other contractors, and Engineer and Engineer's consultants access to the Site to enable Owner to exercise the rights and remedies under this Paragraph.
- C. All claims, costs, losses, and damages (including but not limited to all fees and charges of engineers, architects, attorneys, and other professionals and all court or arbitration or other dispute resolution costs) incurred or sustained by Owner in exercising the rights and remedies under this Paragraph 13.09 will be charged against Contractor, and a Change Order will be issued incorporating the necessary revisions in the Contract Documents with respect to the Work; and Owner shall be entitled to an appropriate decrease in the Contract Price. If the parties are unable to agree as to the amount of the adjustment, Owner may make a Claim therefor as provided in Paragraph 10.05. Such claims, costs, losses and damages will include but not be limited to all costs of repair, or replacement of work of others destroyed or damaged by correction, removal, or replacement of Contractor's defective Work.
- D. Contractor shall not be allowed an extension of the Contract Times because of any delay in the performance of the Work attributable to the exercise by Owner of Owner's rights and remedies under this Paragraph 13.09.

ARTICLE 14 – PAYMENTS TO CONTRACTOR AND COMPLETION

14.01 *Schedule of Values*

- A. The Schedule of Values established as provided in Paragraph 2.07.A will serve as the basis for progress payments and will be incorporated into a form of Application for Payment acceptable to Engineer. Progress payments on account of Unit Price Work will be based on the number of units completed.

14.02 *Progress Payments*

A. *Applications for Payments:*

1. ~~At least 20 days before the date established in the Agreement for each progress payment (but not more often than once a month), Contractor shall submit to Engineer for review an Application for Payment filled out and signed by Contractor covering the Work completed as of the date of the Application and accompanied by such supporting documentation as is required by the Contract Documents. On the first Working Day following the 25th of each month, CMAR shall submit to Owner for review an Application for Payment filled out and signed by CMAR covering the Work completed as of the date of the Application and~~

accompanied by such supporting documentation as is required by the Contract Documents. If payment is requested on the basis of materials and equipment not incorporated in the Work but delivered and suitably stored at the Site or at another location agreed to in writing, the Application for Payment shall also be accompanied by a bill of sale, invoice, or other documentation warranting that Owner has received the materials and equipment free and clear of all Liens and evidence that the materials and equipment are covered by appropriate property insurance or other arrangements to protect Owner's interest therein, all of which must be satisfactory to Owner.

2. Beginning with the second Application for Payment, each Application shall include an affidavit of Contractor stating that all previous progress payments received on account of the Work have been applied on account to discharge Contractor's legitimate obligations associated with prior Applications for Payment.
3. The amount of retainage with respect to progress payments will be as stipulated in the Agreement.

B. *Review of Applications:*

1. Engineer will, within 10 days after receipt of each Application for Payment, either indicate in writing a recommendation of payment and present the Application to Owner or return the Application to Contractor indicating in writing Engineer's reasons for refusing to recommend payment. In the latter case, Contractor may make the necessary corrections and resubmit the Application.
2. Engineer's recommendation of any payment requested in an Application for Payment will constitute a representation by Engineer to Owner, based on Engineer's observations of the executed Work as an experienced and qualified design professional, and on Engineer's review of the Application for Payment and the accompanying data and schedules, that to the best of Engineer's knowledge, information and belief:
 - a. the Work has progressed to the point indicated;
 - b. the quality of the Work is generally in accordance with the Contract Documents (subject to an evaluation of the Work as a functioning whole prior to or upon Substantial Completion, the results of any subsequent tests called for in the Contract Documents, a final determination of quantities and classifications for Unit Price Work under Paragraph 9.07, and any other qualifications stated in the recommendation); and
 - c. the conditions precedent to Contractor's being entitled to such payment appear to have been fulfilled in so far as it is Engineer's responsibility to observe the Work.
3. By recommending any such payment Engineer will not thereby be deemed to have represented that:
 - a. inspections made to check the quality or the quantity of the Work as it has been performed have been exhaustive, extended to every aspect of the Work in progress, or involved detailed inspections of the Work beyond the responsibilities specifically assigned to Engineer in the Contract Documents; or

- b. there may not be other matters or issues between the parties that might entitle Contractor to be paid additionally by Owner or entitle Owner to withhold payment to Contractor.
4. Neither Engineer's review of Contractor's Work for the purposes of recommending payments nor Engineer's recommendation of any payment, including final payment, will impose responsibility on Engineer:
- a. to supervise, direct, or control the Work, or
 - b. for the means, methods, techniques, sequences, or procedures of construction, or the safety precautions and programs incident thereto, or
 - c. for Contractor's failure to comply with Laws and Regulations applicable to Contractor's performance of the Work, or
 - d. to make any examination to ascertain how or for what purposes Contractor has used the moneys paid on account of the Contract Price, or
 - e. to determine that title to any of the Work, materials, or equipment has passed to Owner free and clear of any Liens.
5. Engineer may refuse to recommend the whole or any part of any payment if, in Engineer's opinion, it would be incorrect to make the representations to Owner stated in Paragraph 14.02.B.2. Engineer may also refuse to recommend any such payment or, because of subsequently discovered evidence or the results of subsequent inspections or tests, revise or revoke any such payment recommendation previously made, to such extent as may be necessary in Engineer's opinion to protect Owner from loss because:
- a. the Work is defective, or completed Work has been damaged, requiring correction or replacement;
 - b. the Contract Price has been reduced by Change Orders;
 - c. Owner has been required to correct defective Work or complete Work in accordance with Paragraph 13.09; or
 - d. Engineer has actual knowledge of the occurrence of any of the events enumerated in Paragraph 15.02.A.

C. Payment Becomes Due:

- 1. ~~Ten~~ Thirty days after presentation of the Application for Payment to Owner with Engineer's recommendation, the amount recommended will (subject to the provisions of Paragraph 14.02.D) become due, and when due will be paid by Owner to Contractor.

D. Reduction in Payment:

- 1. Owner may refuse to make payment of the full amount recommended by Engineer because:

- a. claims have been made against Owner on account of Contractor's performance or furnishing of the Work;
 - b. Liens have been filed in connection with the Work, except where Contractor has delivered a specific bond satisfactory to Owner to secure the satisfaction and discharge of such Liens;
 - c. there are other items entitling Owner to a set-off against the amount recommended;
 - d. Owner has actual knowledge of the occurrence of any of the events enumerated in Paragraphs 14.02.B.5.a through 14.02.B.5.c or Paragraph 15.02.A;
 - e. Owner has been notified of failure to make payments to Subcontractors or Suppliers or for labor;
 - f. failure to submit up-to-date record documents as required by GC-6.12,;
 - g. failure to submit monthly Progress Schedule updates or revised schedules as requested by the Owner or Engineer; or
 - h. failure to provide Project photographs required by Specifications.
2. If Owner refuses to make payment of the full amount recommended by Engineer, Owner will give Contractor immediate written notice (with a copy to Engineer) stating the reasons for such action and promptly pay Contractor any amount remaining after deduction of the amount so withheld. Owner shall promptly pay Contractor the amount so withheld, or any adjustment thereto agreed to by Owner and Contractor, when Contractor remedies the reasons for such action to Owner's satisfaction.
 3. Upon a subsequent determination that Owner's refusal of payment was not justified, the amount wrongfully withheld shall be treated as an amount due as determined by Paragraph 14.02.C.1 and subject to interest as provided in the Agreement.
 4. Owner may permanently withhold payment from Contract Price for
 - a. liquidated damages incurred by CMAR, or
 - b. compensation for Engineer for overtime charges of Resident Project Representative, third review of submittals, review of substitutions, re-inspection fees, inspections or designs related to correction of defective Work, or other Services identified as requiring payment by the CMAR. Compensation will be based on the following rates:

Position	Hourly Rate
Principal in Charge	\$275
Project Manager	\$205
Project Engineer	\$165
Construction Manager	\$165

Resident Engineer	\$145
Resident Project Representative	\$125
Senior Resident Representative	\$160
Design Engineer	\$145
Engineering Technician	\$115
Clerk	\$60
Expenses will be billed at the actual cost multiplied by 1.15.	

- c. Costs for tests performed by the Owner to verify that Work previously tested and found to be defective has been corrected. Verification testing is to be provided at the CMAR's expense to verify products or Work are in compliance after corrections have been made.

14.03 *Contractor's Warranty of Title*

- A. Contractor warrants and guarantees that title to all Work, materials, and equipment covered by any Application for Payment, whether incorporated in the Project or not, will pass to Owner no later than the time of payment free and clear of all Liens.

14.04 *Substantial Completion*

- A. When Contractor considers the entire Work ready for its intended use, Contractor shall notify Owner and Engineer in writing that the entire Work is substantially complete (except for items specifically listed by Contractor as incomplete) and request that Engineer issue a certificate of Substantial Completion.
- B. Promptly after Contractor's notification, Owner, Contractor, and Engineer shall make an inspection of the Work to determine the status of completion. If Engineer does not consider the Work substantially complete, Engineer will notify Contractor in writing giving the reasons therefor.
- C. If Engineer considers the Work substantially complete, Engineer will deliver to Owner a tentative certificate of Substantial Completion which shall fix the date of Substantial Completion. There shall be attached to the certificate a tentative list of items to be completed or corrected before final payment. Owner shall have seven days after receipt of the tentative certificate during which to make written objection to Engineer as to any provisions of the certificate or attached list. If, after considering such objections, Engineer concludes that the Work is not substantially complete, Engineer will, within 14 days after submission of the tentative certificate to Owner, notify Contractor in writing, stating the reasons therefor. If, after consideration of Owner's objections, Engineer considers the Work substantially complete, Engineer will, within said 14 days, execute and deliver to Owner and Contractor a definitive certificate of Substantial Completion (with a revised tentative list of items to be completed or corrected) reflecting such changes from the tentative certificate as Engineer believes justified after consideration of any objections from Owner.

- D. At the time of delivery of the tentative certificate of Substantial Completion, Engineer will deliver to Owner and Contractor a written recommendation as to division of responsibilities pending final payment between Owner and Contractor with respect to security, operation, safety, and protection of the Work, maintenance, heat, utilities, insurance, and warranties and guarantees. Unless Owner and Contractor agree otherwise in writing and so inform Engineer in writing prior to Engineer's issuing the definitive certificate of Substantial Completion, Engineer's aforesaid recommendation will be binding on Owner and Contractor until final payment.
- E. Owner shall have the right to exclude Contractor from the Site after the date of Substantial Completion subject to allowing Contractor reasonable access to remove its property and complete or correct items on the tentative list.

14.05 *Partial Utilization*

- A. Prior to Substantial Completion of all the Work, Owner may use or occupy any substantially completed part of the Work which has specifically been identified in the Contract Documents, or which Owner, Engineer, and Contractor agree constitutes a separately functioning and usable part of the Work that can be used by Owner for its intended purpose without significant interference with Contractor's performance of the remainder of the Work, subject to the following conditions:
 - 1. Owner at any time may request Contractor in writing to permit Owner to use or occupy any such part of the Work which Owner believes to be ready for its intended use and substantially complete. If and when Contractor agrees that such part of the Work is substantially complete, Contractor, Owner, and Engineer will follow the procedures of Paragraph 14.04.A through D for that part of the Work.
 - 2. Contractor at any time may notify Owner and Engineer in writing that Contractor considers any such part of the Work ready for its intended use and substantially complete and request Engineer to issue a certificate of Substantial Completion for that part of the Work.
 - 3. Within a reasonable time after either such request, Owner, Contractor, and Engineer shall make an inspection of that part of the Work to determine its status of completion. If Engineer does not consider that part of the Work to be substantially complete, Engineer will notify Owner and Contractor in writing giving the reasons therefor. If Engineer considers that part of the Work to be substantially complete, the provisions of Paragraph 14.04 will apply with respect to certification of Substantial Completion of that part of the Work and the division of responsibility in respect thereof and access thereto.
 - 4. No use or occupancy or separate operation of part of the Work may occur prior to compliance with the requirements of Paragraph 5.10 regarding property insurance.

14.06 *Final Inspection*

- A. Upon written notice from Contractor that the entire Work or an agreed portion thereof is complete, Engineer will promptly make a final inspection with Owner and Contractor and will notify Contractor in writing of all particulars in which this inspection reveals that the Work is incomplete

or defective. Contractor shall immediately take such measures as are necessary to complete such Work or remedy such deficiencies.

14.07 *Final Payment*

A. *Application for Payment:*

1. After Contractor has, in the opinion of Engineer, satisfactorily completed all corrections identified during the final inspection and has delivered, in accordance with the Contract Documents, all maintenance and operating instructions, schedules, guarantees, bonds, certificates or other evidence of insurance, certificates of inspection, marked-up record documents (as provided in Paragraph 6.12), and other documents, Contractor may make application for final payment following the procedure for progress payments.
2. The final Application for Payment shall be accompanied (except as previously delivered) by:
 - a. all documentation called for in the Contract Documents, including but not limited to the evidence of insurance required by Paragraph 5.04.B.6;
 - b. consent of the surety, if any, to final payment;
 - c. a list of all Claims against Owner that Contractor believes are unsettled; and
 - d. complete and legally effective releases or waivers (satisfactory to Owner) of all Lien rights arising out of or Liens filed in connection with the Work.
3. In lieu of the releases or waivers of Liens specified in Paragraph 14.07.A.2 and as approved by Owner, Contractor may furnish receipts or releases in full and an affidavit of Contractor that: (i) the releases and receipts include all labor, services, material, and equipment for which a Lien could be filed; and (ii) all payrolls, material and equipment bills, and other indebtedness connected with the Work for which Owner might in any way be responsible, or which might in any way result in liens or other burdens on Owner's property, have been paid or otherwise satisfied. If any Subcontractor or Supplier fails to furnish such a release or receipt in full, Contractor may furnish a bond or other collateral satisfactory to Owner to indemnify Owner against any Lien.

B. *Engineer's Review of Application and Acceptance:*

1. If, on the basis of Engineer's observation of the Work during construction and final inspection, and Engineer's review of the final Application for Payment and accompanying documentation as required by the Contract Documents, Engineer is satisfied that the Work has been completed and Contractor's other obligations under the Contract Documents have been fulfilled, Engineer will, within ten days after receipt of the final Application for Payment, indicate in writing Engineer's recommendation of payment and present the Application for Payment to Owner for payment. At the same time Engineer will also give written notice to Owner and Contractor that the Work is acceptable subject to the provisions of Paragraph 14.09. Otherwise, Engineer will return the Application for Payment to Contractor, indicating in writing the reasons for refusing to recommend final payment, in which case Contractor shall make the necessary corrections and resubmit the Application for Payment.

C. *Payment Becomes Due:*

1. ~~Thirty days after the presentation to Owner of the Application for Payment and accompanying documentation, the amount recommended by Engineer, less any sum Owner is entitled to set off against Engineer's recommendation, including but not limited to liquidated damages, will become due and will be paid by Owner to Contractor. The first Working Day following the 20th day of the second month following the submittal of the final Application for Payment and accompanying documentation, the amount recommended by the Engineer, less any sum Owner is entitled to set off against Engineer's recommendation, including but not limited to liquidated damages, will become due and will be paid by Owner to CMAR.~~

14.08 *Final Completion Delayed*

- A. If, through no fault of Contractor, final completion of the Work is significantly delayed, and if Engineer so confirms, Owner shall, upon receipt of Contractor's final Application for Payment (for Work fully completed and accepted) and recommendation of Engineer, and without terminating the Contract, make payment of the balance due for that portion of the Work fully completed and accepted. If the remaining balance to be held by Owner for Work not fully completed or corrected is less than the retainage stipulated in the Agreement, and if bonds have been furnished as required in Paragraph 5.01, the written consent of the surety to the payment of the balance due for that portion of the Work fully completed and accepted shall be submitted by Contractor to Engineer with the Application for such payment. Such payment shall be made under the terms and conditions governing final payment, except that it shall not constitute a waiver of Claims.

14.09 *Waiver of Claims*

- ~~A. The making and acceptance of final payment will constitute:
 1. a waiver of all Claims by Owner against Contractor, except Claims arising from unsettled Liens, from defective Work appearing after final inspection pursuant to Paragraph 14.06, from failure to comply with the Contract Documents or the terms of any special guarantees specified therein, or from Contractor's continuing obligations under the Contract Documents; and
 2. a waiver of all Claims by Contractor against Owner other than those previously made in accordance with the requirements herein and expressly acknowledged by Owner in writing as still unsettled.~~

The making and acceptance of final payment will constitute a waiver of all Claims by Contractor against Owner other than those previously made in accordance with the requirements herein and expressly acknowledged by Owner in writing as still unsettled.

ARTICLE 15 – SUSPENSION OF WORK AND TERMINATION

15.01 *Owner May Suspend Work*

- A. At any time and without cause, Owner may suspend the Work or any portion thereof for a period of not more than 90 consecutive days by notice in writing to Contractor and Engineer which will fix the date on which Work will be resumed. Contractor shall resume the Work on the date so

fixed. Contractor shall be granted an adjustment in the Contract Price or an extension of the Contract Times, or both, directly attributable to any such suspension if Contractor makes a Claim therefor as provided in Paragraph 10.05.

15.02 *Owner May Terminate for Cause*

- A. The occurrence of any one or more of the following events will justify termination for cause:
1. Contractor's persistent failure to perform the Work in accordance with the Contract Documents (including, but not limited to, failure to supply sufficient skilled workers or suitable materials or equipment or failure to adhere to the Progress Schedule established under Paragraph 2.07 as adjusted from time to time pursuant to Paragraph 6.04);
 2. Contractor's disregard of Laws or Regulations of any public body having jurisdiction;
 3. Contractor's repeated disregard of the authority of Engineer; or
 4. Contractor's violation in any substantial way of any provisions of the Contract Documents.
 5. If CMAR fails to provide the replacement bond required by General Conditions, Section 5.01.C or insurance coverage as required by General Conditions Article 5.
 6. If any petition of bankruptcy is filed by or against CMAR, or if CMAR is adjudged as bankrupt or insolvent or makes a general assignment for the benefit of creditors, or if a receiver is appointed for the benefit of CMAR's creditors, or if a receiver is appointed on account of CMAR's insolvency, upon the occurrence of any such event, Owner shall be entitled to request of CMAR or its successor in interest adequate assurance of future performance in accordance with the terms and conditions hereof. Failure to comply with such request within 7 days of delivery of the request shall entitle Owner to terminate this Agreement and to the accompanying rights set forth in Paragraphs 15.02 and 15.03 hereof. In all events pending receipt of adequate assurance of performance and actual performance in accordance therewith, Owner shall be entitled to proceed with the Work with its own forces or with other contractors on a time and material or other appropriate basis. The Cost of Work by Owner or other contractors will be back charged against the Contract Sum hereof.
- B. If one or more of the events identified in Paragraph 15.02.A occur, Owner may, after giving Contractor (and surety) seven days written notice of its intent to terminate the services of Contractor:
1. exclude Contractor from the Site, and take possession of the Work and of all Contractor's tools, appliances, construction equipment, and machinery at the Site, and use the same to the full extent they could be used by Contractor (without liability to Contractor for trespass or conversion);
 2. incorporate in the Work all materials and equipment stored at the Site or for which Owner has paid Contractor but which are stored elsewhere; and
 3. complete the Work as Owner may deem expedient.

- C. If Owner proceeds as provided in Paragraph 15.02.B, Contractor shall not be entitled to receive any further payment until the Work is completed. If the unpaid balance of the Contract Price exceeds all claims, costs, losses, and damages (including but not limited to all fees and charges of engineers, architects, attorneys, and other professionals and all court or arbitration or other dispute resolution costs) sustained by Owner arising out of or relating to completing the Work, such excess will be paid to Contractor. If such claims, costs, losses, and damages exceed such unpaid balance, Contractor shall pay the difference to Owner. Such claims, costs, losses, and damages incurred by Owner will be reviewed by Engineer as to their reasonableness and, when so approved by Engineer, incorporated in a Change Order. When exercising any rights or remedies under this Paragraph, Owner shall not be required to obtain the lowest price for the Work performed.
- D. Notwithstanding Paragraphs 15.02.B and 15.02.C, Contractor's services will not be terminated if Contractor begins within seven days of receipt of notice of intent to terminate to correct its failure to perform and proceeds diligently to cure such failure within no more than 30 days of receipt of said notice.
- E. Where Contractor's services have been so terminated by Owner, the termination will not affect any rights or remedies of Owner against Contractor then existing or which may thereafter accrue. Any retention or payment of moneys due Contractor by Owner will not release Contractor from liability.
- ~~F. If and to the extent that Contractor has provided a performance bond under the provisions of Paragraph 5.01.A, the termination procedures of that bond shall supersede the provisions of Paragraphs 15.02.B and 15.02.C.~~

15.03 *Owner May Terminate For Convenience*

- A. Upon seven days written notice to Contractor and Engineer, Owner may, without cause and without prejudice to any other right or remedy of Owner, terminate the Contract. In such case, Contractor shall be paid for (without duplication of any items):
 - 1. completed and acceptable Work executed in accordance with the Contract Documents prior to the effective date of termination, including fair and reasonable sums for overhead and profit on such Work;
 - 2. expenses sustained prior to the effective date of termination in performing services and furnishing labor, materials, or equipment as required by the Contract Documents in connection with uncompleted Work, plus fair and reasonable sums for overhead and profit on such expenses;
 - 3. all claims, costs, losses, and damages (including but not limited to all fees and charges of engineers, architects, attorneys, and other professionals and all court or arbitration or other dispute resolution costs) incurred in settlement of terminated contracts with Subcontractors, Suppliers, and others; and
 - 4. reasonable expenses directly attributable to termination.
- B. Contractor shall not be paid on account of loss of anticipated profits or revenue or other economic loss arising out of or resulting from such termination.

15.04 *Contractor May Stop Work or Terminate*

- A. If, through no act or fault of Contractor, (i) the Work is suspended for more than 90 consecutive days by Owner or under an order of court or other public authority, or (ii) Engineer fails to act on any Application for Payment within 30 days after it is submitted, or (iii) Owner fails for 30 days to pay Contractor any sum finally determined to be due, then Contractor may, upon seven days written notice to Owner and Engineer, and provided Owner or Engineer do not remedy such suspension or failure within that time, terminate the Contract and recover from Owner payment on the same terms as provided in Paragraph 15.03.
- B. In lieu of terminating the Contract and without prejudice to any other right or remedy, if Engineer has failed to act on an Application for Payment within 30 days after it is submitted, or Owner has failed for 30 days to pay Contractor any sum finally determined to be due, Contractor may, seven days after written notice to Owner and Engineer, stop the Work until payment is made of all such amounts due Contractor, including interest thereon. The provisions of this Paragraph 15.04 are not intended to preclude Contractor from making a Claim under Paragraph 10.05 for an adjustment in Contract Price or Contract Times or otherwise for expenses or damage directly attributable to Contractor's stopping the Work as permitted by this Paragraph.

ARTICLE 16 – DISPUTE RESOLUTION

16.01 *Methods and Procedures*

- ~~A. Either Owner or Contractor may request mediation of any Claim submitted to Engineer for a decision under Paragraph 10.05 before such decision becomes final and binding. The mediation will be governed by the Construction Industry Mediation Rules of the American Arbitration Association in effect as of the Effective Date of the Agreement. The request for mediation shall be submitted in writing to the American Arbitration Association and the other party to the Contract. Timely submission of the request shall stay the effect of Paragraph 10.05.E.~~
- ~~B. Owner and Contractor shall participate in the mediation process in good faith. The process shall be concluded within 60 days of filing of the request. The date of termination of the mediation shall be determined by application of the mediation rules referenced above.~~
- ~~C. If the Claim is not resolved by mediation, Engineer's action under Paragraph 10.05.C or a denial pursuant to Paragraphs 10.05.C.3 or 10.05.D shall become final and binding 30 days after termination of the mediation unless, within that time period, Owner or Contractor:
 - 1. ~~elects in writing to invoke any dispute resolution process provided for in the Supplementary Conditions; or~~
 - 2. ~~agrees with the other party to submit the Claim to another dispute resolution process; or~~
 - 3. ~~gives written notice to the other party of the intent to submit the Claim to a court of competent jurisdiction.~~~~
- A. Owner and CMAR may exercise such rights or remedies as either may otherwise have under the Contract Documents or by Law.

ARTICLE 17 – MISCELLANEOUS

17.01 *Giving Notice*

- A. Whenever any provision of the Contract Documents requires the giving of written notice, it will be deemed to have been validly given if:
1. delivered in person to the individual or to a member of the firm or to an officer of the corporation for whom it is intended; or
 2. delivered at or sent by registered or certified mail, postage prepaid, to the last business address known to the giver of the notice.

17.02 *Computation of Times*

- A. When any period of time is referred to in the Contract Documents by days, it will be computed to exclude the first and include the last day of such period. If the last day of any such period falls on a Saturday or Sunday or on a day made a legal holiday by the law of the applicable jurisdiction, such day will be omitted from the computation.
- B. All references and conditions for a "Calendar Day Contract" in the General Conditions shall apply for a "Fixed Date Contract." A "Fixed Date Contract" is one in which the calendar dates for reaching Substantial Completion and/or final completion are specified in lieu of identifying the actual Calendar Days involved.

17.03 *Cumulative Remedies*

- A. The duties and obligations imposed by these General Conditions and the rights and remedies available hereunder to the parties hereto are in addition to, and are not to be construed in any way as a limitation of, any rights and remedies available to any or all of them which are otherwise imposed or available by Laws or Regulations, by special warranty or guarantee, or by other provisions of the Contract Documents. The provisions of this Paragraph will be as effective as if repeated specifically in the Contract Documents in connection with each particular duty, obligation, right, and remedy to which they apply.

17.04 *Survival of Obligations*

- A. All representations, indemnifications, warranties, and guarantees made in, required by, or given in accordance with the Contract Documents, as well as all continuing obligations indicated in the Contract Documents, will survive final payment, completion, and acceptance of the Work or termination or completion of the Contract or termination of the services of Contractor.

17.05 *Controlling Law*

- A. This Contract is to be governed by the law of the ~~state in which the Project is located~~ State of Texas.

17.06 *Headings*

- A. Article and paragraph headings are inserted for convenience only and do not constitute parts of these General Conditions.

17.07 *Assignment*

- A. This Contract may not be assigned in whole or in part by the CMAR without the prior written consent of the Owner.

ADDENDA

See Attached Issued Addenda

ADDENDA

NTD14624 Lower Bois d'Arc Creek Reservoir Program -
Raw Water Pipeline and Leonard Water Treatment Plant
To McKinney No. 4 Treated Water Pipeline Project

00 91 13

NORTH TEXAS MUNICIPAL WATER DISTRICT

**REQUEST FOR PROPOSALS
CONSTRUCTION MANAGER AT RISK
LOWER BOIS D' ARC CREEK RESERVOIR PROGRAM –
RAW WATER PIPELINE AND LEONARD WATER TREATMENT PLANT
TO MCKINNEY NO. 4 TREATED WATER PIPELINE PROJECT
PROJECT NO. 424 AND Project No. 425
NTD14624**

**ADDENDUM NO. 4
OCTOBER 25, 2016**

PROPOSAL DATE: October 28, 2016, 2:00 PM

The following additions, deletions, modifications, or clarifications shall be made to the appropriate sections of the Request For Proposals and shall become a part of the Contract Documents. Proposers shall acknowledge receipt of this Addendum in the space provided on the Proposal form.

A4-1 00 72 00 Standard General Conditions of the Construction Contract, Section 11.01 A.1. (c)(3):

Delete Section 11.01 A.1. (c)(3) in its entirety and replace with, "The costs of premiums for all bonds and insurance, except for Builder's Risk Insurance, Contractor is required by the Contract Documents to purchase and maintain."

A4-2 00 72 00 Standard General Conditions of the Construction Contract, Section 11.01A.1 (b):

Section 11.01A.1 (b) is amended to add the following language after the word "Work": "and the cost of Builder's Risk Insurance premiums."

A revised 00 72 00 Standard General Conditions of the Construction Contract is attached to this Addendum No.4.

END OF ADDENDUM NO. 4

NORTH TEXAS MUNICIPAL WATER DISTRICT

**REQUEST FOR PROPOSALS
CONSTRUCTION MANAGER AT RISK
LOWER BOIS D' ARC CREEK RESERVOIR PROGRAM –
RAW WATER PIPELINE AND LEONARD WATER TREATMENT PLANT
TO MCKINNEY NO. 4 TREATED WATER PIPELINE PROJECT
PROJECT NO. 424 AND Project No. 425
NTD14624**

**ADDENDUM NO. 3
OCTOBER 19, 2016**

PROPOSAL DATE: October 28, 2016, 2:00 PM

The following additions, deletions, modifications, or clarifications shall be made to the appropriate sections of the Request For Proposals and shall become a part of the Contract Documents. Proposers shall acknowledge receipt of this Addendum in the space provided on the Proposal form.

A3-1 Add the following to Appendix A: "3. Updated Raw Water Pipeline Route – (ProposalFig_RWPL.pdf) 4. Updated Treated Water Pipeline Route-(Proposal_FigTWPL.pdf)"

See attached to this Addendum No. 3 pdf files for items 3 and 4 above.

END OF ADDENDUM NO. 3

NORTH TEXAS MUNICIPAL WATER DISTRICT

**REQUEST FOR PROPOSALS
CONSTRUCTION MANAGER AT RISK
LOWER BOIS D' ARC CREEK RESERVOIR PROGRAM –
RAW WATER PIPELINE AND LEONARD WATER TREATMENT PLANT
TO MCKINNEY NO. 4 TREATED WATER PIPELINE PROJECT
PROJECT NO. 424 AND Project No. 425
NTD14624**

**ADDENDUM NO. 2
OCTOBER 14, 2016**

PROPOSAL DATE: October 28, 2016, 2:00 PM

The following additions, deletions, modifications, or clarifications shall be made to the appropriate sections of the Request For Proposals and shall become a part of the Contract Documents. Proposers shall acknowledge receipt of this Addendum in the space provided on the Proposal form.

A2-1: 00 72 00 Standard General Conditions of the Construction Contract; GC-5.04(D)- Delete in their entirety items 1 and 2 from the Table titled "Insurance for Claims of Damages" and replace with the following:

1) <u>General Aggregate</u> <u>(Except Products-Completed Operations)</u>	<u>\$2,000,000/Occurrence</u> <u>\$4,000,000/Aggregate</u> <u>\$31,000,000 Umbrella or Excess Policy</u>
2) <u>Products-Completed Operations Aggregate</u>	<u>\$2,000,000/Occurrence</u> <u>\$4,000,000/Aggregate</u> <u>\$31,000,000 Umbrella or Excess Policy</u>

A2-2: 00 72 00 Standard General Conditions of the Construction Contract; GC-5.04(D)- Delete the following language from the language below the Table titled "Insurance for Claims of Damages":

- "In lieu of elimination, CMAR may provide and maintain Installation Floater insurance for property under the care, custody, or control of CMAR. The Installation Floater insurance shall be a broad form or "All Peril" policy providing coverage for all materials, supplies, machinery, fixtures and equipment which will be incorporated into the Work. Coverage under the CMAR's Installation Floater will include:
 - faulty or defective workmanship, materials, maintenance or construction,
 - cost to remove defective or damaged Work from the Site or to protect it from loss or damage,
 - cost to cleanup and remove pollutants,
 - coverage for testing and startup,

- any loss to property while in transit,
- any loss at the Site,
- any loss while in storage, both on-Site and off-Site, and
- any loss to temporary Work if the value is included in the Contract Price.”
- “CMAR’s Installation Floater will provide limits of insurance adequate to cover the value of the installation.”

A2-3: 00 72 00 Standard General Conditions of the Construction Contract; GC-5.04(E)- Add the following new sentence after the first sentence: “Automobile Liability Insurance will extend to Hired and Non-Owned Autos.”

END OF ADDENDUM NO. 2

NORTH TEXAS MUNICIPAL WATER DISTRICT

**REQUEST FOR PROPOSALS
CONSTRUCTION MANAGER AT RISK
LOWER BOIS D' ARC CREEK RESERVOIR PROGRAM –
RAW WATER PIPELINE AND LEONARD WATER TREATMENT PLANT
TO MCKINNEY NO. 4 TREATED WATER PIPELINE PROJECT
PROJECT NO. 424 AND Project No. 425
NTD14624**

**ADDENDUM NO. 1
OCTOBER 6, 2016**

PROPOSAL DATE: October 28, 2016, 2:00 PM

The following additions, deletions, modifications, or clarifications shall be made to the appropriate sections of the Request For Proposals and shall become a part of the Contract Documents. Proposers shall acknowledge receipt of this Addendum in the space provided on the Proposal form.

A1-1 00 42 23, Article 6, Section 6.01:

Delete item 6," Section 5: Equipment Testing and Project Startup Plan" and item 7," Section 6: Quality Control Plan and Risk Management Plan" in their entirety.

Replace with a new item 6, "Section 5: Quality Control Plan and Risk Management Plan".

A new copy of 00 42 23 for Proposers use in submitting its Proposal is attached to the addendum.

END OF ADDENDUM NO. 1