

TRANS-TEXAS WATER PROGRAM

West Central
Study Area
Phase I
Interim Report

Volume 4

San Antonio River
Authority

San Antonio Water
System

Edwards Underground
Water District

Guadalupe-Blanco
River Authority

Lower Colorado River
Authority

Bexar Metropolitan
Water District

Nueces River
Authority

Texas Water
Development Board



January, 1996

HDR

HDR Engineering, Inc.
in association with
Paul Price Associates, Inc.
LBG-Guyton Associates
H. B. Zachry Company

TRANS-TEXAS WATER PROGRAM
WEST CENTRAL STUDY AREA

PHASE I
INTERIM REPORT

VOLUME 4

Prepared for

San Antonio River Authority
San Antonio Water System
Edwards Underground Water District
Guadalupe-Blanco River Authority
Lower Colorado River Authority
Bexar Metropolitan Water District
Nueces River Authority
Texas Water Development Board

by

HDR Engineering, Inc.
in association with
Paul Price Associates, Inc.
LBG-Guyton Associates
H.B. Zachry Company

January, 1996

HDR
HDR Engineering, Inc.

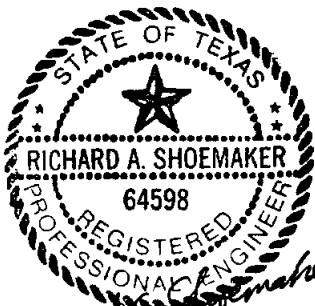

Richard A. Shoemaker
1/23/96

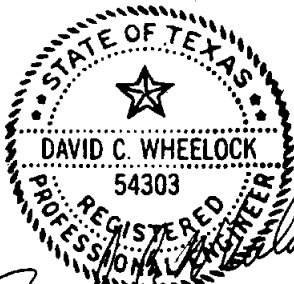

David C. Wheelock
1/23/96



Kenneth L. Choffel
1/23/96

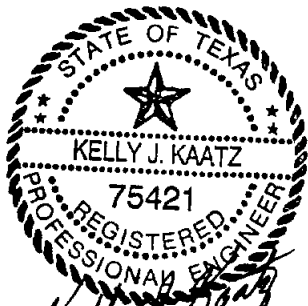

Kelly J. Kaatz
1/23/96

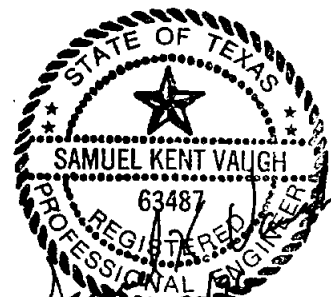

Samuel Kent Vaughn
1/23/96

**TRANS-TEXAS WATER PROGRAM
WEST CENTRAL STUDY AREA
PHASE I INTERIM REPORT**

TABLE OF CONTENTS

VOLUME 1

<u>Section</u>	<u>Page</u>
ES EXECUTIVE SUMMARY	ES-1
1.0 INTRODUCTION	1-1
1.1 Study Area.....	1-2
1.2 Objectives	1-5
2.0 POPULATION, WATER DEMAND, AND WATER SUPPLY PROJECTIONS	2-1
2.1 Population Projections	2-1
2.2 Water Demand Projections.....	2-16
2.3 Water Supply Projections.....	2-84
2.4 Water Demand and Supply Comparisons.....	2-96

VOLUME 2

3.0 WATER SUPPLY ALTERNATIVES AND EVALUATIONS.....	3-1
3.0.1 Environmental Overview	3-7
3.0.2 Cost Estimating Procedures.....	3-47

Conservation / Local Alternatives

3.1 Demand Reduction (L-10).....	3-57
3.2 Exchange Reclaimed Water for Edwards Irrigation Water (L-11).....	3-73
3.3 Exchange Reclaimed Water for BMA Medina Lake Water (L-12)	3-91
3.4 Reclaimed Water Reuse (L-13)	3-105
3.5 Transfer of Reclaimed Water to Corpus Christi Through Choke Canyon Reservoir (L-14).....	3-117
3.6 Purchase (or Lease) of Edwards Irrigation Water for Municipal and Industrial Use (L-15).....	3-127
3.7 Demineralization of Edwards "Bad Water" (L-16).....	3-147
3.8 Natural Recharge - Type 1 Projects (Maximum Size) (L-17)	3-155
3.9 Natural Recharge - Type 2 Projects (Optimum Size) (L-18)	3-171
3.10 Springflow Augmentation (L-19)	3-185
3.11 Existing Water Rights in Nueces River Basin (N-10).....	3-207

Table of Contents (continued)

VOLUME 2 (continued)

Section	Page
San Antonio River Basin	
3.12 San Antonio River Unappropriated Streamflow (S-10, S-11, S-12)	3-211
3.13 Medina Lake (S-13)	3-219
3.14 Applewhite Reservoir (S-14)	3-235
3.15 Cibolo Reservoir (S-15)	3-255
3.16 Goliad Reservoir (S-16)	3-273
Guadalupe River Basin	
3.17 Guadalupe River Unappropriated Streamflow (G-10, G-11, G-12, G-13, G-14)	3-291
3.18 Diversion of San Marcos River Unappropriated Streamflow (G-13)	3-303
3.19 Diversion of Guadalupe River at Lake Dunlap Unappropriated Streamflow (G-14)	3-317
3.20 Canyon Lake (Released to Lake Dunlap) (G-15)	3-331
3.21 Cuero Reservoir (G-16)	3-343
3.22 Lindenau Reservoir (G-17)	3-365
3.23 McFaddin Reservoir (G-18)	3-389
Minor Reservoirs	
3.24 Guadalupe River Dam 7 (G-19)	3-407
3.25 Gonzales Reservoir (G-20)	3-417
3.26 Lockhart Reservoir (G-21)	3-423
3.27 Dilworth Reservoir (G-22)	3-429
Colorado River Basin	
3.28 Colorado River at Lake Austin (C-10, C-11, C-12, C-13)	3-435
3.29 Colorado River at Columbus (C-14, C-15, C-16, C-17)	3-459
3.30 Shaws Bend Reservoir (C-18)	3-473
Brazos and Sabine River Basins	
3.31 Allens Creek Reservoir (B-10)	3-485
3.32 Toledo Bend Reservoir (SB-10)	3-503
3.33 Allens Creek Reservoir and Toledo Bend Reservoir (SBB-10)	3-517

Table of Contents (continued)

VOLUME 2 (continued)

Section	Page
Carrizo Aquifer	
3.34 Carrizo-Wilcox Aquifer (CZ-10)	3-529

VOLUME 3

3.35 Canyon Lake Area Water Supply (G-23)	3-549
3.36 Wimberley and Woodcreek Water Supply from Canyon Lake (G-24)	3-571
3.37 Northeast Hays and Northwest Caldwell Counties Water Supply From Near Lake Dunlap (G-25)	3-585
3.38 Mid-Cities (IH-35 and Highway 78) Water Supply From Near Lake Dunlap (G-26)	3-599
3.39 Lower Guadalupe River Basin Water Requirements	3-613
3.40 Guadalupe River Diversion Near Lake Dunlap with Transfer of Downstream Rights (G-27)	3-619
3.41 Guadalupe River Diversion Near Gonzales with Transfer of Downstream Rights (G-28)	3-639
3.42 Transfer of SAWS Reclaimed Water to Coletto Creek Reservoir (L-20)	3-657

VOLUME 4

3.43 Guadalupe River Diversion Near Comfort to Recharge Zone via Medina Lake (G-30)	3-675
3.43.1 Description of Alternative	3-675
3.43.2 Available Yield	3-675
3.43.3 Environmental Issues	3-679
3.43.4 Water Quality and Treatability	3-688
3.43.5 Engineering and Costing	3-688
3.43.6 Implementation Issues	3-690
3.44 Diversion of Canyon Lake Flood Storage to Recharge Zone via Cibolo Creek (G-32)	3-695
3.44.1 Description of Alternative	3-695
3.44.2 Available Yield	3-695
3.44.3 Environmental Issues	3-700
3.44.4 Water Quality and Treatability	3-706
3.44.5 Engineering and Costing	3-706
3.44.6 Implementation Issues	3-710

Table of Contents (continued)

VOLUME 4 (continued)

Section	Page
3.45 Guadalupe River Diversion Near Lake Dunlap to Recharge Zone with Enhanced Springflow, Water Rights Transfer, and Unappropriated Streamflow (G-33)	3-713
3.45.1 Description of Alternative	3-713
3.45.2 Available Yield.....	3-715
3.45.3 Environmental Issues.....	3-718
3.45.4 Water Quality and Treatability.....	3-727
3.45.5 Engineering and Costing.....	3-727
3.45.6 Implementation Issues.....	3-731
3.46 Cibolo Reservoir with Imported Water from the San Antonio, Guadalupe, and Colorado Rivers (S-15D)	3-733
3.46.1 Description of Alternative	3-733
3.46.2 Available Yield.....	3-735
3.46.3 Environmental Issues.....	3-737
3.46.4 Water Quality and Treatability.....	3-749
3.46.5 Engineering and Costing.....	3-750
3.46.6 Implementation Issues	3-761
3.47 Cibolo Reservoir with Imported Water from the Saltwater Barrier and Colorado River (S-15E)	3-763
3.47.1 Description of Alternative	3-763
3.47.2 Available Yield.....	3-765
3.47.3 Environmental Issues.....	3-767
3.47.4 Water Quality and Treatability.....	3-776
3.47.5 Engineering and Costing.....	3-776
3.47.6 Implementation Issues.....	3-781
3.48 Upper Cibolo Creek Reservoir Cost Analyses (S-17)	3-783
3.48.1 Description of Alternative	3-783
3.48.2 Available Yield.....	3-786
3.48.3 Environmental Issues.....	3-787
3.48.4 Water Quality and Treatability.....	3-793
3.48.5 Engineering and Costing.....	3-793
3.48.6 Implementation Issues	3-801

Table of Contents (continued)

VOLUME 4 (continued)

Section **Page**

APPENDICES

Bound in Volume 2:

- Appendix A - Report on Carrizo Aquifer
- Appendix B - Protected, Endangered, and Threatened Species
- Appendix C - Trans-Texas Environmental Criteria
- Appendix D - GSA Basin Model - Parameter Summary Tables

Bound in Volume 3:

- Appendix E - Summary Tables of Potential Water Supply Alternatives
- Appendix F - SAWS Proposed Water Resource Plan
- Appendix G - Canyon Lake Firm Yield
- Appendix H - Water Rights Transfers and Firm Availability Analyses
- Appendix I - Errata

Bound in Volume 4:

Appendix J - Water Potentially Available in the Upper Guadalupe River Basin for Edwards Aquifer Recharge Enhancement	J-1
J1 - Storage and Diversion of Unappropriated Water Upstream of Canyon Lake (G-29)	J-3
J2 - Purchase of Canyon Lake Water for Upstream Diversion (G-30)	J-8
J3 - Canyon Lake Storage Reallocation (G-31)	J-14
J4 - Diversion of Canyon Lake Flood Storage from Canyon Lake (G-32)	J-17
J5 - Water Available Below Comal and San Marcos Springs (G-33)	J-21
Appendix K - Summary of Potential Water Supply Alternatives	K-1

LIST OF TABLES

VOLUME 4

Table	Title	Page
3.43-1	Cost Estimate for Guadalupe River Diversion Near Comfort to Recharge Zone Via Medina Lake (G-30).....	3-691
3.44-1	Cost Estimate for Diversion from Canyon Lake Flood Storage to Recharge Zone Via Cibolo Creek (G-32).....	3-708
3.45-1	Cost Estimate for Guadalupe River Diversion Near Lake Dunlap to Recharge Zone With Enhanced Springflow, Water Rights Transfer, and Unappropriated Flow (G-33).....	3-729
3.46-1	Summary of Firm Yield Estimates for Cibolo Reservoir with Imported Water from the San Antonio, Guadalupe, and Colorado Rivers (S-15D).....	3-738
3.46-2	Cost Estimates for Cibolo Reservoir with Imported Water from the San Antonio, Guadalupe, and Colorado Rivers (S-15D) (Original Trans-Texas Environmental Criteria).....	3-752
3.46-3	Cost Estimates for Cibolo Reservoir with Imported Water from the San Antonio and Guadalupe Rivers (S-15D) (Alternative Trans-Texas Environmental Criteria for Run-of-the-River Diversions).....	3-760
3.47-1	Summary of Firm Yield Estimates, Cibolo Reservoir with Imported Water from the Saltwater Barrier and Colorado River (S-15E).....	3-768
3.47-2	Cost Estimates for Cibolo Reservoir with Imported Water from the Saltwater Barrier and Colorado River (S-15E).....	3-778
3.48-1	Cost Estimates for the Study and Mitigation of Upper Cibolo Creek Reservoir Project.....	3-793
3.48-2	Cost Estimate for Upper Cibolo Creek Reservoir.....	3-798

LIST OF FIGURES

VOLUME 4

Figure	Title	Page
3.43-1	Upper Guadalupe River Recharge Enhancement (G-30).....	3-676
3.43-2	Water Availability Summary (G-30).....	3-678
3.43-3	Impact on Canyon Lake Firm Yield (G-30).....	3-680
3.43-4	Changes in Streamflow - Guadalupe River near Comfort (G-30).....	3-684
3.43-5	Optimization Summary (G-30)	3-692
3.44-1	Upper Guadalupe River Recharge Enhancement (G-32).....	3-696
3.44-2	Water Availability Summary (G-32).....	3-698
3.44-3	Changes in Streamflow - Diversion from Canyon Lake (G-32).....	3-704
3.44-4	Optimization Summary (G-32)	3-709
3.45-1	Upper Guadalupe River Recharge Enhancement (G-33).....	3-714
3.45-2	Water Availability Summary (G-33).....	3-719
3.45-3	Changes in Streamflow - Diversion from Lake Dunlap (G-33)	3-723
3.45-4	Optimization Summary (G-33)	3-730
3.46-1	Cibolo Reservoir with Imported Water (S-15D)	3-734
3.46-2	Changes in Streamflow - San Antonio and Guadalupe Rivers (S-15D)	3-744
3.46-3	Changes in Streamflow - Cibolo Creek and Saltwater Barrier (S-15D).....	3-745
3.46-4	Optimization Summary - San Antonio River Only (S-15D)	3-753
3.46-5	Optimization Summary - With Guadalupe River (S-15D).....	3-755
3.46-6	Optimization Summary - With Colorado River (S-15D).....	3-756
3.46-7	Optimization Summary - San Antonio River Only Alternative Environmental Criteria	3-758
3.46-8	Optimization Summary - With Guadalupe River Alternative Environmental Criteria	3-759
3.47-1	Cibolo Reservoir With Imported Water (S-15E)	3-764
3.47-2	Changes in Streamflow - Cibolo Creek and Saltwater Barrier (S-15E).....	3-775
3.47-3	Optimization Summary - Saltwater Barrier Only (S-15E)	3-779
3.48-1	Upper Cibolo Creek Reservoir (S-17)	3-784
3.48-2	Upper Cibolo Creek Reservoir Topographic Site Map (S-17).....	3-785
3.48-3	Conceptual Embankment Dam Section.....	3-795
3.48-4	Upper Cibolo Creek Dam Centerline Profile.....	3-796

3.43 Guadalupe River Diversion Near Comfort to Recharge Zone via Medina Lake (G-30)

3.43.1 Description of Alternative

Alternative G-30 includes the diversion of water from the Guadalupe River near Comfort and importation of this water for enhancement of Edwards Aquifer recharge. With respect to water potentially available for diversion, this alternative includes two primary sources: 1) Unappropriated streamflow; and 2) Flows that would otherwise have been impounded in Canyon Lake. Water available from both of these sources was computed subject to senior water rights (excluding storage rights in Canyon Lake) and Trans-Texas Environmental Criteria. Resulting impacts to storage rights in Canyon Lake were quantified as the reduction in firm yield. As shown in Figure 3.43-1, the major facilities associated with this alternative include a channel dam, intake structure, and pump station on the Guadalupe River; an import pipeline to a tributary of the Medina River; an intake structure and pump station at Diversion Lake (located just downstream of Medina Lake); a transmission pipeline from Diversion Lake to the selected recharge area; and a series of small recharge enhancement dams located primarily in northwestern Bexar County.

3.43.2 Available Yield

The available yield for Alternative G-30 would be realized in the form of enhanced Edwards Aquifer recharge obtained through the importation of water from the Guadalupe River near Comfort and its delivery to the recharge zone via Medina Lake. The procedures and assumptions pertinent to the computation of water potentially available and associated reductions in Canyon Lake firm yield are described in the following paragraphs. For additional information regarding comparable estimates of water availability from the Guadalupe River near Spring Branch and associated impacts to Canyon Lake, refer to Appendix J.

In order to quantify unappropriated streamflow potentially available for diversion, it was first necessary to estimate the portion of the total streamflow passing Comfort which is dedicated to downstream diversion rights and required to be passed through Canyon Lake. This task was accomplished using the Guadalupe - San Antonio River Basin Model¹ (GSA Model) assuming full subordination of hydropower water rights to Canyon Lake, fixed Edwards Aquifer pumpage of

¹ HDR Engineering, Inc., "Guadalupe - San Antonio River Basin Recharge Enhancement Study," Edwards Underground Water District, September, 1993.

400,000 acft/yr, return flows at rates reported in 1988, and diversion of the uncommitted firm yield of Canyon Lake at Lake Dunlap after honoring Guadalupe-Blanco River Authority (GBRA) contractual commitments from Canyon Lake totaling 38,438 acft/yr. These general assumptions were used in all water availability analyses for Alternative G-30. Water potentially available for diversion was computed as the total streamflow at Comfort less the greater of the minimum desired monthly instream flow under Trans-Texas Environmental Criteria for Instream Flows (Appendix C, Volume 2) or the flow to be passed for downstream water rights excluding storage rights in Canyon Lake. Effects of diversions near Comfort on storage rights in Canyon Lake were subsequently quantified by the resulting reduction in firm yield. Daily gaged flows for the Guadalupe River at Spring Branch (ID#1675) for the 1934-89 period were analyzed in order to determine a typical percentage of water available on a monthly basis which could be diverted on a daily basis subject to water rights, environmental flow criteria, and daily streamflow variations. Based on this analysis, it was estimated that 80 percent of the monthly volume of streamflow available for diversion from the Guadalupe River near Comfort could be diverted considering the daily distribution of flows. Water availability is presented for a range of maximum diversion rates in Figure 3.43-2.

Optimization analyses considering a range of potential import pipeline diameters were performed to select the most appropriate importation facilities for this alternative based on minimum unit cost and reasonable incremental unit cost of Edwards Aquifer recharge enhancement. These optimization analyses (described in Section 3.43.5) resulted in the selection of a 72-inch diameter import pipeline from the Guadalupe River. Water potentially available for diversion via a 72-inch diameter pipeline would average 42,000 acft/yr over the long-term (1934-89) and 11,000 acft/yr during drought conditions (1947-56). As is apparent in Figure 3.43-2, water availability would be highly variable from year to year and severely limited or non-existent during some drought years.

Information presented in Figure 3.43-2 represents water potentially available at the point of diversion on the Guadalupe River. The water ultimately available for Edwards Aquifer recharge enhancement, however, would be somewhat less considering channel losses in delivery via the Medina River and evaporation losses in Medina Lake. For the purposes of this study, it

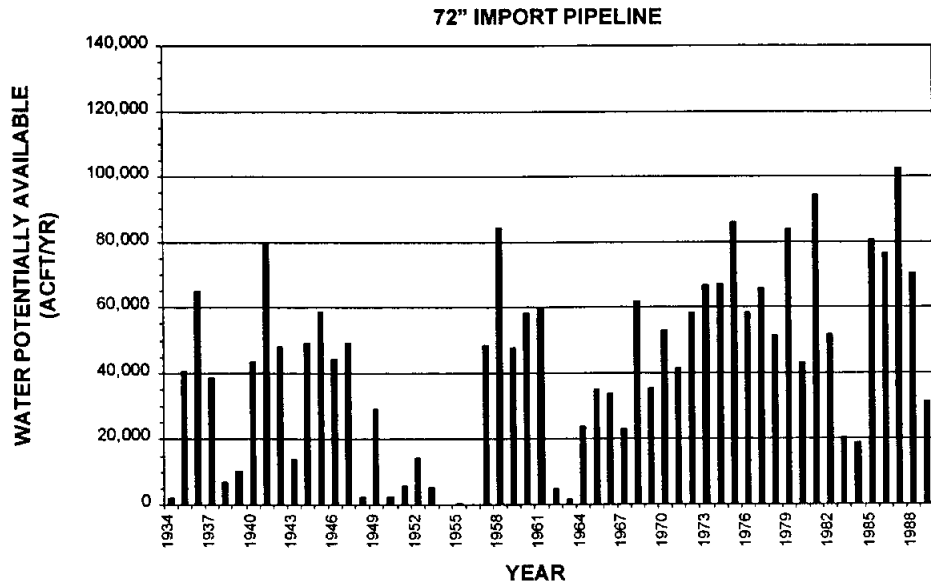
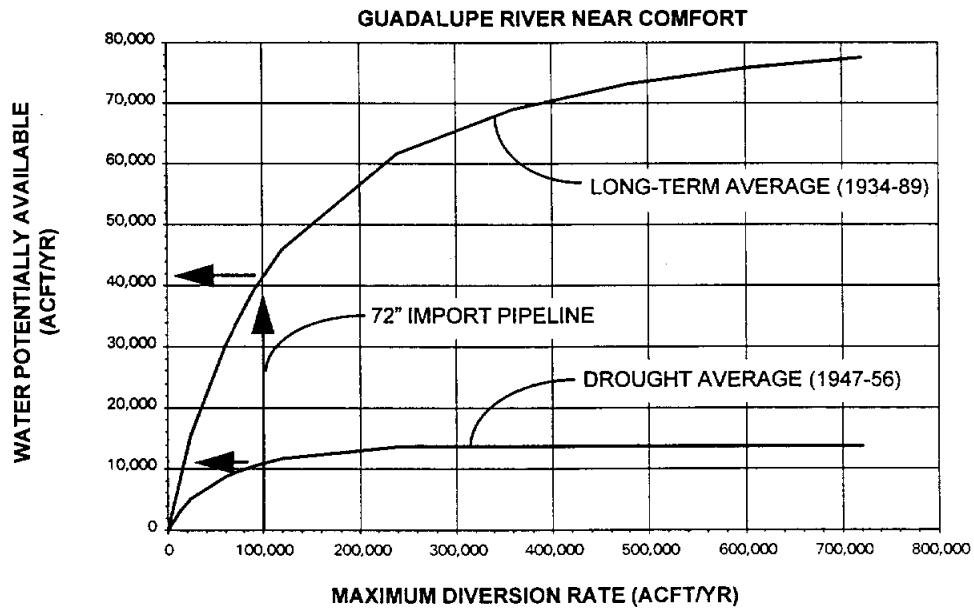

ASSUMPTIONS:

1. SPRING FLOWS RESULTING FROM FIXED EDWARDS AQUIFER PUMPAGE OF 400,000 ACFT/YR.
2. HYDROPOWER WATER RIGHTS FULLY SUBORDINATED TO CANYON LAKE.
3. UNCOMMITTED FIRM YIELD OF CANYON LAKE DIVERTED NEAR NEW BRAUNFELS.
4. RETURN FLOWS SET AT RATES OBSERVED IN 1988.
5. IMPORT DIVERSIONS SUBJECT TO ORIGINAL TRANS-TEXAS ENVIRONMENTAL CRITERIA.

TRANS TEXAS WATER PROGRAM /
WEST CENTRAL STUDY AREA



**WATER AVAILABILITY
SUMMARY
ALTERNATIVE G-30**

was estimated that 90 percent of the water imported from the Guadalupe River would be available for recharge enhancement.

Although water available for upstream diversion under this alternative was initially computed without consideration of storage rights in Canyon Lake, resultant impacts to the firm yield were subsequently quantified using the GSA Model and are presented in Figure 3.43-3 for a range of maximum upstream diversion rates. Based on the selected 72-inch pipeline diameter, diversion of water potentially available from the Guadalupe River near Comfort would reduce the firm yield of Canyon Lake by about 5,000 acft/yr or about 6 percent. Annual costs for the purchase of this water from the firm yield of Canyon Lake to offset this reduction are included in the cost estimate for Alternative G-30 presented in Section 3.43.5.

3.43.3 Environmental Issues

Alternative G-30 involves diverting water from the Guadalupe River upstream of the City of Comfort (Kendall County) and downstream of the City of Center Point (Kerr County) to Medina Lake/Diversion Lake via Mason Creek and the Medina River (Figure 3.43-1). Water would then be diverted from Diversion Lake to the Edwards Aquifer recharge zone in northeastern Medina County and northern Bexar County. Alternative G-30 includes water transmission pipelines between the Guadalupe River and Elm Pass near Mason Creek, and between Diversion Lake and the recharge zone. The pipeline between the Guadalupe River and Elm Pass will follow the alignment of an existing cross-country pipeline. The pipeline between Diversion Lake and the recharge zone in Alternative G-33 is similar to that in Alternative S-13B (Section 3.13, Volume 2).

The pipeline between the Guadalupe River and Mason Creek lies within Kerr County. Water delivered to Mason Creek would flow through Kerr, Bandera and Medina Counties in Mason Creek, a short segment of Bandera Creek, the Medina River, Medina Lake, and Diversion Lake. The pipeline from Diversion Lake to the recharge zone lies within Medina and Bexar Counties and the Edwards Plateau Vegetational Area.

The Edwards Plateau is a deeply dissected, rapidly drained rocky plain with broad, flat to undulating divides. Historically, the vegetation was grassland or open savannah-type plains with tree or brushy species found along rocky slopes and stream bottoms. In Medina and Bexar

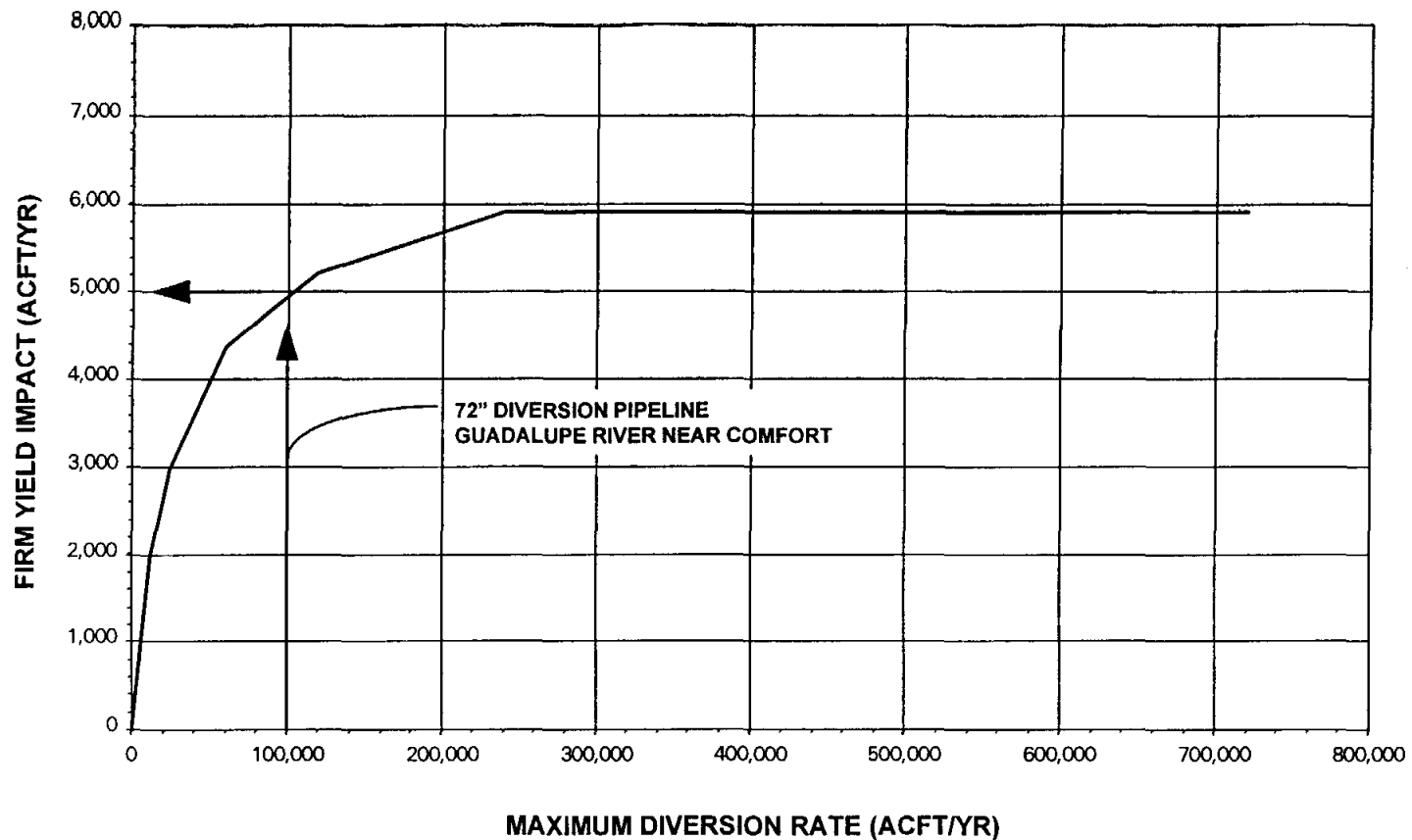

ASSUMPTIONS:

1. SPRING FLOWS RESULTING FROM FIXED EDWARDS AQUIFER PUMPAGE OF 400,000 ACFT/YR.
2. HYDROPOWER WATER RIGHTS FULLY SUBORDINATED TO CANYON LAKE.
3. UNCOMMITTED FIRM YIELD OF CANYON LAKE DIVERTED NEAR NEW BRAUNFELS.
4. RETURN FLOWS SET AT RATES OBSERVED IN 1988.
5. IMPORT DIVERSIONS SUBJECT TO ORIGINAL TRANS-TEXAS ENVIRONMENTAL CRITERIA.

TRANS TEXAS WATER PROGRAM /
WEST CENTRAL STUDY AREA



HDR Engineering, Inc.

**IMPACT ON
CANYON LAKE FIRM YIELD
ALTERNATIVE G-30**

FIGURE 3.43-3

Counties the Balcones Escarpment forms a distinct border of the plateau on its southern boundary with the South Texas Plains. Streams and rivers fed by numerous springs have cut canyons through the plateau, especially near its margins, forming unique niches for a variety of plant species. The ferns as well as many of the flowering plants are primarily lithophilous ("rock-loving"), and are represented primarily by various species of lipferns (*Cheilanthes spp.*), cloak-ferns (*Notholaena spp.*) and cliff brakes (*Pellaea spp.*). Columbine (*Aquilegia canadensis*), and endemics such as *Anemone edwardsensis* and wand butterfly-bush (*Buddleja racemosa*) are sometimes found together with other species on large boulders in shaded ravines along with such species as mock-orange (*Philadelphus spp.*), American smoke-tree (*Cotinus americana*), spicebush (*Benzoin aestivale*), and the endemic silver bells (*Styrax platanifolia and S. texana*).

The most important climax grasses of the Plateau include switchgrass, several species of bluestems and gramas, Indian grass (*Sorghastrum nutans*), Canada wild-rye (*Elymus canadensis*), curly mesquite (*Hilaria berlanderi*), and buffalograss (*Buchloe dactyloides*). The rough, rocky areas typically support a tall or mid-grass understory and a brush overstory complex consisting primarily of live oak (*Quercus virginiana*), Texas oak (*Q. buckleyi*), shinnery oak (*Q. havardii*), juniper species (*Juniperus*) and mesquite (*Prosopis glandulosa*). Throughout the region, the brush species are generally considered as "invaders" with the climax stages composed of grassland or open savannah. The steeper canyon slopes historically supported a dense oak-Ashe juniper thicket.

The Balcones Escarpment is characterized by a complex of porous, faulted limestones in stream beds, sinkholes and fractures which allow substantial volumes of water to flow into the Edwards Aquifer.² The Edwards recharge zone has a surface area of about 1,500 square miles in Uvalde, Kinney, Medina, Bexar, Hays and Comal Counties. Streamflows contribute significantly to recharge of the Edwards Aquifer³ which supplies water to customers in the City of San Antonio and numerous other users. Additionally, the Edwards Aquifer feeds springs which provide habitat for several endemic, endangered species.

² Caran, C.S. 1982. Lineament analysis and inference of geologic structure.

³ United States Geological Survey. 1989. Compilation of Hydrologic Data for the Edwards Aquifer, San Antonio Area, Texas, 1988. With 1934-1988 Summary, Bulletin 48, November, 1989.

The proposed water line from the Guadalupe River to Mason Creek is about 5.15 miles long. It would cross vegetative habitats classified as live oak-Ashe juniper park, live oak-mesquite-Ashe juniper park, and live oak Ashe juniper wood.⁴ Acreage affected during construction would total 87.4 acres based on a right-of-way (ROW) 140 feet in width. This acreage would include 3.4 acres (3.6 percent) of riparian scrub bordering the Guadalupe River, 2.3 acres (2.6 percent) of brush, 7.7 acres (8.8 percent) of crop, 1.9 acres (2.2 percent) of riparian woodland (Verde Creek), 28 acres (32 percent) of grass and 44.4 acres (50.8 percent) of park. A ROW 40 feet wide maintained for the life of the project would affect a total of 25 acres.

Important species in Kerr, Bandera, Medina and Bexar Counties are listed in Appendix B of Volume 2. Habitat for several endangered species could be encountered along the pipeline route. The Golden-cheeked warbler (*Dendroica chrysoparia*) requires mature Ashe juniper in dense oak-Ashe juniper stands for nesting. The Black-capped Vireo (*Vireo atricapillus*) nests in semi-open woods with a dense brushy understory. The Golden-cheeked Warbler and the Black-capped Vireo are listed by U.S. Fish and Wildlife Service and Texas Parks and Wildlife Department as endangered species. However, habitat for these birds can be avoided by carefully routing the pipeline in the early planning stages. Other important species with potential habitat along the pipeline corridor include the Texas horned lizard (*Phrynosoma cornutum*), Texas tortoise (*Gopherus berlandieri*), and Indigo snake (*Drymarchon corais erebennus*). The Texas tortoise is a federal candidate species and all three of these reptile species are listed as threatened in Texas. Habitat and endangered species surveys of the proposed pipeline corridor should be conducted in a later phase of the study if this alternative continues to be developed.

Mason Creek is an intermittent stream that flows into Bandera Creek about 2000 feet upstream of its confluence with the Medina River. Implementation of Alternative G-30 would increase the frequency of flows in Mason Creek and about 2000 feet of Bandera Creek. Flow studies (including environmental analyses) of Mason Creek and the Medina River should be performed as part of subsequent investigations.

Modeling flows in the Guadalupe River near Comfort indicated a reduction in median annual flows from 121,927 acft without the project to 72,322 acft with implementation of

⁴ McMahan, C.A., R.G. Frye and K.L. Brown. 1984. The Vegetation Types of Texas Including Cropland. TPWD, Austin, TX

Alternative G-30. Monthly median flow estimates without Alternative G-30 ranged from 9,162 acft to 3,744 acft without the project and from 6,447 acft to 2,893 acft with the project (Figure 34.3-4). Estimated percent reductions in the monthly medians ranged from 47.9 percent to 19.8 percent. Plotting average annual streamflows with and without the project in deciles indicated that the least proportional reductions would occur in the lowest and highest flow regimes (Figure 34.3-4). Reductions in flow could have an effect on the biological communities below the diversion and above Canyon Lake. For example, the relative abundance of fish species collected in a study conducted on the Guadalupe River appeared to be affected by instream flows.⁵ Some species of fish, as well as other organisms, can be expected to be less tolerant of flow reductions than others. Flows below Canyon Dam and at the Saltwater Barrier are not expected to be affected significantly by this project as most of the water diverted for recharge enhancement would otherwise have been impounded and stored in Canyon Lake.

The Guadalupe River downstream from the City of Comfort flows through Kendall County. The interior least tern (*Sterna antillarum athalassos*), a seasonal migrant, is reported to occur in Kendall County. The interior least tern, which is listed by U.S. Fish and Wildlife Service and Texas Parks and Wildlife Department as endangered, nests on large sandbars on the Red River. The tern is unlikely to be affected by Alternative G-30. Cagle's map turtle (*Graptemys caglei*), Guadalupe bass (*Micropterus treculi*) and blue sucker (*Cycleptus elongatus*) are federal candidate species that could be affected by the diversion infrastructure and/or flow reductions in the Guadalupe River below the City of Center Point. The blue sucker is listed by Texas Parks and Wildlife Department as threatened in Texas. Studies of the Guadalupe River in the area around the diversion infrastructure, and of the downstream reaches should be conducted in later phases of the study before implementing Alternative G-30.

A pipeline route between Diversion Lake and the recharge zone is described in Section 3.13 in Volume 2. Some of the following information was extracted from Section 3.13 with modifications appropriate to Alternative G-30. A construction ROW 8.2 miles long extending

⁵Academy of Natural Sciences, Philadelphia. 1991. Report No. 91-27. Philadelphia, Pennsylvania.

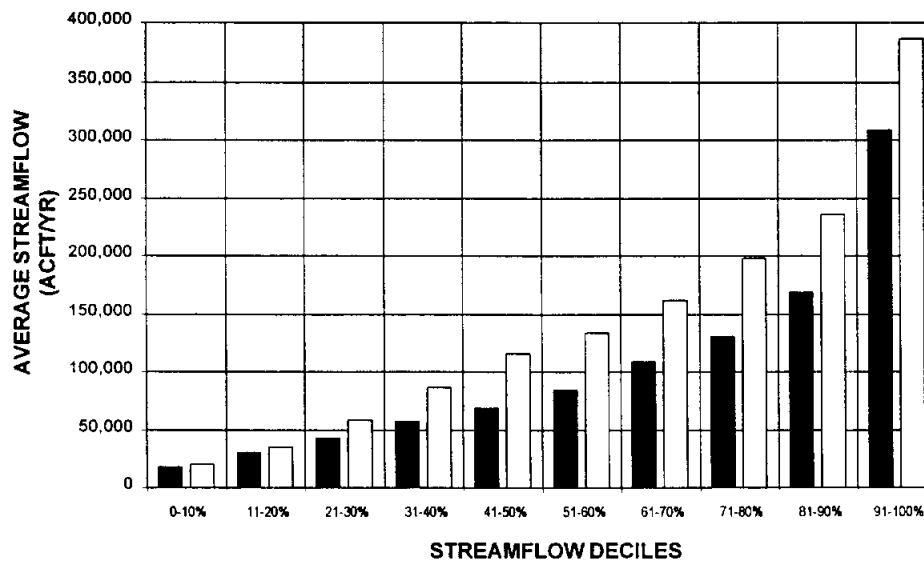
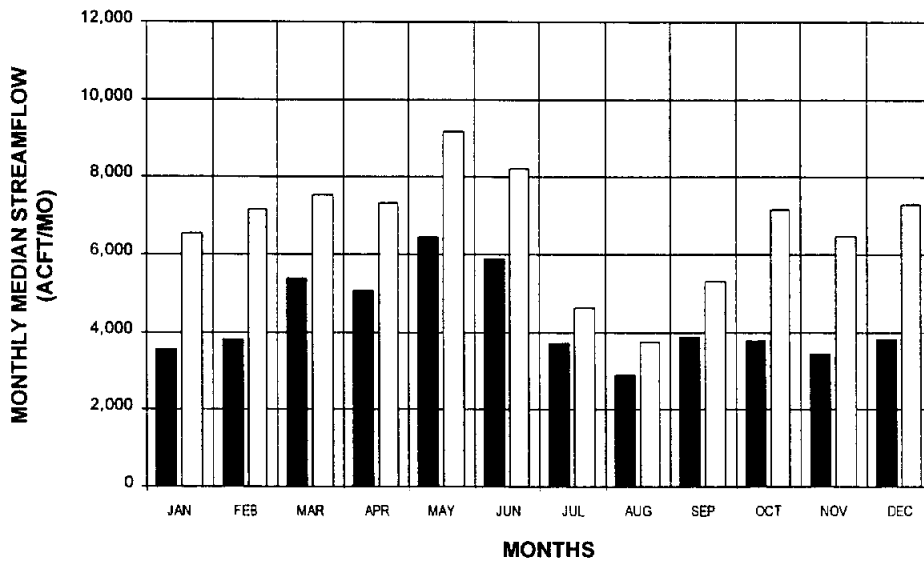

LEGEND:

- WITH PROJECT
- WITHOUT PROJECT

NOTE: STATISTICS BASED ON 1934-89 HISTORICAL PERIOD

TRANS TEXAS WATER PROGRAM / WEST CENTRAL STUDY AREA



CHANGES IN STREAMFLOW GUADALUPE RIVER NEAR COMFORT, ALTERNATIVE G-30

HDR Engineering, Inc.

FIGURE 3.43-4

from Diversion Lake to the recharge zone would affect approximately 139.5 acres, including about 76.3 acres (54.7 percent) of brush, 49.7 acres (35.6 percent) of wood and park, 7.5 acres (5.4 percent) of pasture, and 6 acres (4.3 percent) of riparian brush.

Soil types in the vicinity of Medina Lake are characterized by the undulating Brackett association and undulating Tarrant Rock outcrop association on uplands with slopes from 1 to 8 percent. The steep Tarrant-Brackett association is found on uplands with steep slopes between 20 and 45 percent. These areas are low in available water capacity, and are used for range and wildlife habitat.⁶

Vegetation surrounding Medina Lake includes Live Oak-mesquite-Ashe juniper parks and woods. Existing wetland habitats within the lake boundaries are classified as lacustrine and consist of deep and shallow open-water habitats where wetland vegetation is not a dominant feature. In upstream and downstream reaches of the Medina River, the Medina Irrigation Canal, Diversion Lake, and tributary streams, riverine and palustrine wetlands occur. These areas are generally small in size and are typically associated with a drainage feature or water body. In addition to open-water and streambed wetland areas, small areas of forested wetlands dominated by either broad-leaved deciduous or needle-leaved deciduous species occur downstream of Medina Dam.

Because Medina Lake is an existing reservoir, Alternative G-30 would not have direct impacts on existing land uses within the reservoir boundaries. For Alternative G-30, a volume of water equal to about 90 percent of that diverted from the Guadalupe River would be diverted from Diversion Lake for transmission to the recharge zone. Thus, the quantity of recharge to the Edwards Aquifer would increase under this scenario. Water surface elevations in Medina Lake would continue to fluctuate essentially as they do at present. Streamflows in the Medina River downstream of Diversion Lake would be essentially unaffected by this project.

One Category 2 federal candidate species, bracted twistflower (*Streptanthus bracteatus*), has been reported near Medina Lake (Table 37, Appendix B, Volume 2). Because no inundation will occur outside the existing reservoir, this species will not be affected by this alternative. The widemouth blindcat (*Satan eurystomus*) and the toothless blindcat (*Trogloglanis pattersoni*), both

⁶ U.S. Department of Agriculture, Soil Conservation Service (SCS). 1977. Soil Survey of Bandera County, Texas. In cooperation with Texas Agricultural Experiment Station, Texas A&M University, College Station.

candidates for federal listing and listed by Texas Parks and Wildlife Department, are troglobitic species known only from deep wells in the Edwards Aquifer beneath the City of San Antonio. Because Alternative G-30 is expected to increase recharge and not affect recharge water quality, adverse impacts on these species are not anticipated.

No impacts to cultural resources are anticipated as a result of modified Medina Lake operations. Cultural resources surveys will be required in areas to be disturbed by the construction of the infrastructure to implement Alternative G-30. Because Medina Lake is an existing reservoir, no mitigation requirements are anticipated for the reservoir itself. Mitigation may be required for impacts associated with the infrastructure if sensitive ecological or cultural resources are identified in the future.

Waters imported from the Guadalupe River to Medina Lake and, subsequently, withdrawn from Diversion Lake are to be delivered to a proposed series of small recharge enhancement dams located primarily in northern Bexar County. The terrestrial habitat impacts associated with these recharge dams will depend on the amount of clearing done, frequency of inundation, and the rapidity of pool drainage following delivery of imported water or capture of local runoff. As the alignment of the pipeline from Diversion Lake and the exact locations and sizes of recharge dams are not known at this time, specific estimates of associated acreage affected were not computed.

Because these recharge dams are designed to facilitate direct percolation into karst features (fractures, holes, and/or caves) present below the stream channel, disturbance of the local karst system and its fauna is a possibility. The fauna inhabiting these caves are usually small in both species diversity and population size, and are adapted to relatively stable physical habitats, which presumably makes them particularly sensitive to disturbances outside of the natural regime. The results of the investigation of the karst fauna in northern Bexar County, however, seem to indicate that caves with biological communities have not been encountered in streambeds there⁷. Openings in the streambed are naturally exposed to the erosive force of flowing water, lessening the likelihood that an organized "terrestrial" community would be able to develop and persist in such a location.

⁷ Elliot, W.R., 1993, "Cave Fauna Conservation in Texas," Proceedings of the 1991 National Cave Management Symposium, Bowling Green, Kentucky, American Cave Conservation Association, Horse Cave, Kentucky.

Karst openings in the vicinity of these proposed recharge dams that presently experience periodic flooding may be inundated for longer periods, or experience an increase in the maximum elevation to which the water rises following a runoff event, possibly causing flow across the recharge zone. Both terrestrial and aquatic communities are extensive in the karst openings associated with the Edwards limestone, and significant threats to these habitats presently exist as a result of human activities in many areas including northern Bexar County^{8,9}. The extent of intermittently flooded karst zones that would be affected by the recharge dams, the extent to which these zones are inhabited, and how hydrologic changes might affect resident communities, is unknown.

Numerous caves in the vicinity of the proposed recharge dams in northern Bexar County have been explored and the faunas have been inventoried.^{10, 11} Government Canyon Bat Cave supports a population of Cave Myotis bats (*myotis velifer*). Additionally, several of the caves support cave beetles, including *Rhadina infernalis*. There are also caves in the vicinity of San Geronimo Creek (northeastern Medina County), but none have been explored. In the vicinity of Culebra Creek, lack of access to the property has prevented a search for caves. No caves have been identified in the vicinity of Deep or Limekiln Creeks.

A petition to the U.S. Fish and Wildlife Service to list as endangered or threatened nine new species of invertebrates with limited distributions in caves of northern Bexar County, including the *Rhadina* beetle, has been filed (see Table 3.9-3, Volume 2). The petition identifies specific inhabited caves, including Government Canyon Bat Cave, and a study is underway to identify additional habitat areas. All of the proposed recharge dams are in areas that have potential for caves containing endangered species¹².

Government Canyon Bat Cave is located in the immediate vicinity of the potential recharge dam site on Government Creek. Although the known opening of this cave is located well above the impoundment elevation, the depth to which *Cicurina* (Troglotic spider) habitat

⁸ Ibid.

⁹ Longley, G., 1981, "The Edwards Aquifer: Earth's Most Diverse Ground Water Ecosystem?" Internat. J. Speleol. 11:123-128.

¹⁰ Veni, G., Personal Communication, April, 22, 1994.

¹¹ Elliott, W., Personal Communication, November 21, 1995.

¹² Veni, G., Personal Communication, April, 22, 1994.

extends is not known, and additional site surveys would be required to determine whether it might be affected by an increase in the duration of inundation events, or by an increase in the maximum inundation elevation within the cave. On-site surveys of the reservoir and surrounding areas and mitigation or relocation of the recharge dam may be required if caves with protected species are found and will be affected by project development.

Government Canyon, including the Government Canyon Bat Cave site, is the location of a new state park. The Government Canyon State Park plan includes environmental resource preservation, a preserve for nesting Golden-cheeked warblers and Black-capped vireos, and some recreational facilities. Although dam construction may be a concern, natural recharge in the canyon (including water imported from the Guadalupe River via Medina Lake) may not conflict with preserving the environmental resources of the area or the park development plan.

The Government Creek area is known to contain numerous prehistoric sites and a 17th century Spanish colonial trail. Other recharge sites may contain similar cultural resources. Cultural resources protection on public lands in Texas, or lands affected by projects regulated under U.S. Army Corps of Engineers permits, is afforded by the Antiquities Code of Texas (Title 9, Chapter 191, Texas Natural Resource Code of 1977), the National Historic Preservation Act (PL96-515), and the Archaeological and Historic Preservation Act (PL93-291). All areas disturbed during construction will be first surveyed by qualified professionals for the presence of significant cultural resources. Additional measures to mitigate impacts may be required by the presence of significant cultural deposits that cannot be avoided.

3.43.4 Water Quality and Treatability

[To be completed in subsequent phases of the study.]

3.43.5 Engineering and Costing

For this alternative (G-30), water potentially available for diversion from the Guadalupe River near Comfort would be pumped to a tributary of the Medina River for delivery to Diversion Lake below Medina Lake, and pumped from Diversion Lake to a series of recharge enhancement dams located primarily in northwestern Bexar County. The benefits of this project would be enhanced recharge of the Edwards Aquifer resulting in increased water supply for municipal,

industrial, and irrigation use as well as enhanced springflow for recreational use and protection of endangered species. The major facilities required to implement Alternative G-30 include:

- Guadalupe River Intake and Pump Station
- Raw Water Pipeline to Medina River Tributary
- Raw Water Booster Stations
- Reservoir Intake and Pump Station
- Raw Water Pipeline to Recharge Zone
- Recharge Structures

Optimization analyses were performed to select the appropriate import pipeline size for delivery of water from the Guadalupe River to a tributary of the Medina River as well as the appropriate number of structures necessary to ensure recharge of the balance of imported water subsequent to storage in Medina Lake and pumpage from Diversion Lake. In the absence of detailed technical analyses, it was assumed that 90 percent of the volume of water imported from the Guadalupe River would be available for recharge after consideration of channel losses in the Medina River and evaporation losses in Medina Lake. Unit costs and incremental unit costs based on the associated recharge enhancement were computed for import pipelines ranging in diameter from 24 inches to 120 inches. Unit cost is defined to be the Total Annual Cost associated with one import pipeline diameter divided by the resultant recharge enhancement, while incremental unit cost is defined to be the incremental cost divided by the incremental recharge enhancement obtained by comparison with cost and recharge enhancement for the next smaller diameter considered. Import pipeline size was generally selected in accordance with the following criteria: 1) Pipeline diameter greater than or equal to that having the least unit cost for long-term average recharge enhancement; and 2) Largest pipeline diameter with a reasonable incremental unit cost for drought average recharge enhancement.

Diversions from the Guadalupe River through a 72-inch import pipeline could provide for average enhanced Edwards Aquifer recharge of about 37,800 acft/yr at a unit cost of \$239/acft/yr over the long-term (1934-89) and of about 9,900 acft/yr at a unit cost of \$711/acft/yr during drought (1947-56). These unit costs include an intake structure and pump station at Diversion Lake, a 72-inch transmission pipeline from diversion Lake to the recharge area, and several small recharge dams. Project costs and annual costs included to develop the unit costs associated with

this alternative are summarized in Table 3.43-1. Information used to select the 72-inch diameter import pipeline from the Guadalupe River is illustrated in Figure 3.43-5. Key observations upon consideration of Figure 3.43-5 are summarized as follows:

- 1) With a maximum diversion rate of about 102,000 acft/yr (140 cfs), a 72-inch diameter import pipeline could enhance Edwards Aquifer recharge by a long-term average amount of about 37,800 acft/yr and a drought average amount of about 9,900 acft/yr. Based on the sources of water considered, little additional recharge enhancement could be obtained during drought with larger diameter import pipelines.
- 2) On the basis of long-term average unit cost for importation and recharge facilities, a 72-inch diameter import pipeline (\$239/acft/yr) could be chosen based on long-term average recharge enhancement.
- 3) Considering incremental unit cost for importation facilities based on drought average recharge enhancement, a 72-inch diameter import pipeline was selected. "Up-sizing" to a 96-inch or larger diameter would not be recommended, based on the sources of water considered, as additional increments of drought average recharge enhancement would cost more than \$1,100/acft/yr.

3.43.6 Implementation Issues (G-30)

Guadalupe River Channel Dam and Diversion Lake Intake

1. It will be necessary to obtain these permits:
 - a. TNRCC Water Right and Storage permits.
 - b. U.S. Army Corps of Engineers Sections 10 and 404 dredge and fill permits for the channel dam and intake structures.
 - c. GLO Sand and Gravel Removal permits.
 - d. GLO Easement for use of state-owned land.
 - e. Coastal Coordination Council review.
 - f. TPWD Sand, Gravel, and Marl permit.
2. Permitting, at a minimum, will require these studies:
 - a. Habitat mitigation plan.
 - b. Environmental studies.
 - c. Cultural resource studies.
3. Land will need to be acquired through either negotiations or condemnation.

Requirements Specific to Diversion of Water from Guadalupe River

1. Necessary permits:
 - a. TNRCC permit to divert unappropriated water.
 - b. TNRCC Interbasin Transfer Approval.
 - c. TNRCC authorization to use Medina River and its tributaries to deliver Guadalupe River water to Medina Lake and then use the water for recharge purposes in the San Antonio River Basin.

**Table 3.43-1
Cost Estimate for Guadalupe River Diversion Near Comfort to Recharge Zone
Via Medina Lake (G-30)
(Mid 1994 Prices)**

Item	Diversion to Recharge Zone	
	Long-Term Average ¹	Drought Average ²
Capital Costs		
Transmission and Pumping	\$ 34,682,000	
Delivery System	<u>4,555,000</u>	
Total Capital Cost	\$ 39,237,000	
Engineering, Contingencies, and Legal Costs	12,484,000	
Land Acquisition	353,000	
Environmental Studies and Mitigation	2,327,000	
Interest During Construction	<u>2,474,000</u>	
Total Project Cost	\$ 56,875,000	
Annual Costs		
Annual Debt Service	\$ 5,328,000	\$ 5,328,000
Annual Operation and Maintenance	738,000	738,000
Purchase of Water	265,000	265,000
Annual Power Cost	<u>2,700,000</u>	<u>706,000</u>
Total Annual Cost	\$ 9,031,000	\$ 7,037,000
Available Project Yield (acft/yr)	37,800	9,900
Annual Cost of Water (\$/acft/yr)	\$ 239	\$ 711
¹ Long-term average based on 1934-89 historical period.		
² Drought average based on 1947-56 historical period.		

2. Permitting will require these studies:
 - a. Instream flow issues and impact.
 - b. Environmental studies.
 - c. Evaluation of potential impacts to recreation.
3. Agreement with Guadalupe-Blanco River Authority for purchase of firm yield reduction at Canyon Lake.
4. Agreement with Bexar-Medina-Atascosa Counties Water Control and Improvement District to transport water through Medina Lake, and to construct an intake and pump station at Diversion Lake to transfer Guadalupe River water to the recharge zone.

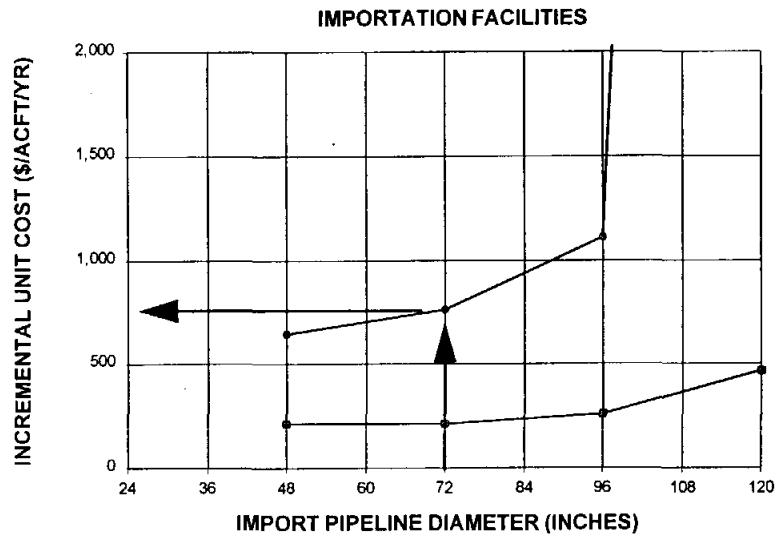
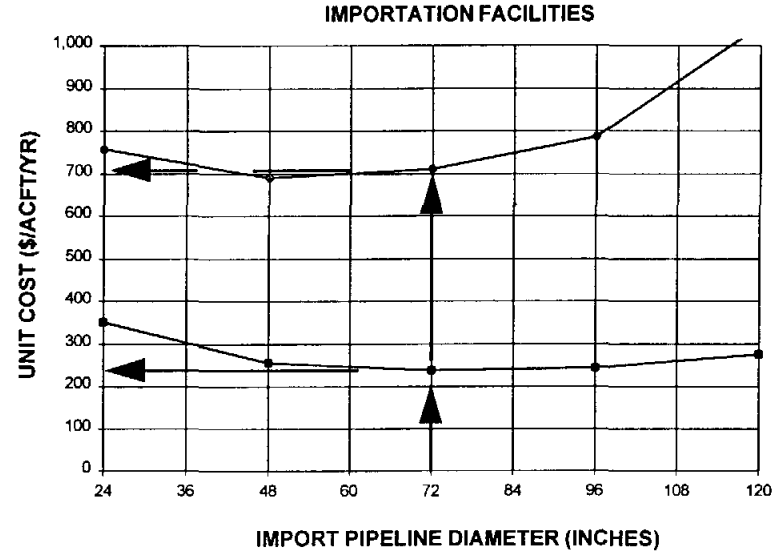
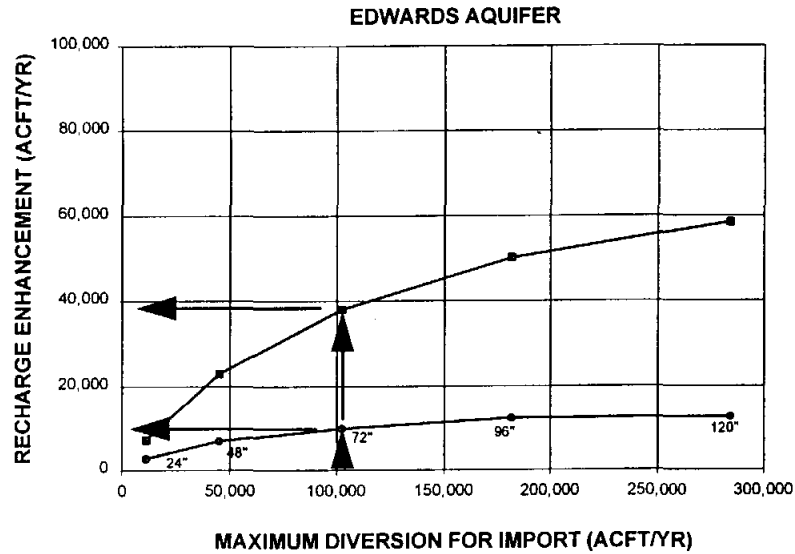

ASSUMPTIONS:

1. DIVERSIONS FROM THE GUADALUPE RIVER NEAR COMFORT FOR IMPORT TO THE EDWARDS AQUIFER RECHARGE ZONE IN NORTHERN BEXAR COUNTY VIA MEDINA LAKE.
2. COST OF RECHARGE ENHANCEMENT STRUCTURES INCLUDED TO ENSURE THAT IMPORTED WATERS ENTER THE EDWARDS AQUIFER.
3. 90 PERCENT EFFICIENCY ASSUMED FOR DELIVERY OF WATER DIVERTED FROM THE GUADALUPE RIVER TO THE RECHARGE ZONE TO ACCOUNT FOR POTENTIAL LOSSES IN MASON CREEK AND THE MEDINA RIVER AS WELL AS EVAPORATION AT MEDINA LAKE.
4. SPRINGFLOWS RESULTING FROM FIXED EDWARDS AQUIFER PUMPAGE OF 400,000 ACFT/YR.
5. HYDROPOWER WATER RIGHTS FULLY SUBORDINATED TO CANYON LAKE.
6. RETURN FLOWS SET AT RATES OBSERVED IN 1988.

LEGEND:

- LONG-TERM AVERAGE (1934-89)
- DROUGHT AVERAGE (1947-56)



HDR Engineering, Inc.

TRANS TEXAS WATER PROGRAM /
WEST CENTRAL STUDY AREA

OPTIMIZATION SUMMARY
ALTERNATIVE G-30

FIGURE 3.43-5

Requirements Specific to Pipelines

1. Necessary permits:
 - a. U.S. Army Corps of Engineers Sections 10 and 404 dredge and fill permits for stream crossings.
 - b. GLO Sand and Gravel Removal permits.
 - c. Coastal Coordination Council review.
 - d. TPWD Sand, Gravel, and Marl permit.
2. Right-of-way and easement acquisition.
3. Crossings:
 - a. Highways and railroads.
 - b. Creeks and rivers.
 - c. Other utilities.

Requirements Specific to Surface Recharge Structures

1. Detailed field investigation of each potential recharge site to determine natural and expected recharge rates.
2. For water imported to the recharge zone: water compatibility testing and assessment of treatment needs (if any), including biological and chemical characteristics.
3. Necessary permits could include:
 - a. TNRCC Water Right and Storage permits.
 - b. U.S. Army Corps of Engineers Sections 10 and 404 dredge and fill permits.
 - c. GLO Sand and Gravel Removal permits.
 - d. TPWD Sand, Gravel, and Marl permit.
4. Permitting, at a minimum, will require these studies:
 - a. Determination of impact plans for parkland, wildlife preserves, and other conservation programs.
 - b. Study of impact on karst geology organisms from a sustained recharge program.
 - c. Other environmental studies.

THIS PAGE LEFT INTENTIONALLY BLANK

3.44 Diversion of Canyon Lake Flood Storage to Recharge Zone via Cibolo Creek (G-32)

3.44.1 Description of Alternative

Alternative G-32 includes the diversion of water from the flood storage pool of Canyon Lake and importation of this water for enhancement of Edwards Aquifer recharge. Canyon Lake is a multi-purpose project located on the Guadalupe River in Comal County about 12 miles northwest of New Braunfels. It was originally developed by the U.S. Army Corps of Engineers in the early 1960's as a water supply and flood control project with an estimated conservation storage capacity of 382,000 acft below elevation 909 ft-MSL and an estimated flood storage capacity of about 355,000 acft between elevation 909 ft-MSL and the crest of the emergency spillway at 943 ft-MSL. Water potentially available for diversion under this alternative is the portion of the flood flows temporarily impounded above 909 ft-MSL which can be diverted during the period that flood releases are being made at Canyon Dam. As shown in Figure 3.44-1, the major facilities associated with this alternative include an intake structure and pump station at Canyon Lake; an import pipeline to a tributary of Cibolo Creek; and a small recharge enhancement dam located on Cibolo Creek at the proposed site of Upper Cibolo Creek Reservoir (see Section 3.48).

3.44.2 Available Yield

The available yield for Alternative G-30 would be realized in the form of enhanced Edwards Aquifer recharge obtained through the importation of water from the flood pool of Canyon Lake and its delivery to the recharge zone via Cibolo Creek. As storage in the flood pool of Canyon Lake is most likely to occur simultaneously with flood events and natural recharge in the Cibolo Creek watershed, a recharge enhancement structure on Cibolo Creek sized to impound about 10,000 acft (see Section 3.9, Volume 2) is included as a component of this alternative. The procedures and assumptions pertinent to the computation of water potentially available from Canyon Lake flood storage and recharge enhancement associated with its importation are described in the following paragraphs.

In order to quantify water potentially available for diversion from Canyon Lake flood storage, it was first necessary to compute the firm yield derived from the conservation storage

pool of Canyon Lake. This task was accomplished using the Guadalupe - San Antonio River Basin Model¹³ (GSA Model) assuming full subordination of hydropower water rights to Canyon Lake, fixed Edwards Aquifer pumpage of 400,000 acft/yr, return flows at rates reported in 1988, and diversion of the uncommitted firm yield of Canyon Lake at Lake Dunlap after honoring Guadalupe-Blanco River Authority (GBRA) contractual commitments from Canyon Lake totaling 38,438 acft/yr. The total firm yield of Canyon Lake subject to these assumptions is 81,450 acft/yr. Review of this simulation reveals that Canyon Lake would have temporarily impounded some water in the flood pool in about 50 percent of the months during the 1934-89 period. During the critical drought period extending from July, 1947 through February, 1958, however, there would have been no storage in the flood pool and no water available for diversion under this alternative.

Current guidelines for flood releases from Canyon Lake are set forth in Schedule #1 from the U.S. Army Corps of Engineers Reservoir Regulation Manual. These guidelines generally provide for the release of 1,500 cfs (2,975 acft/day) when the lake level is between 909 ft-MSL and 911 ft-MSL and 5,000 cfs (9,920 acft/day or 302,000 acft/month) when the lake level exceeds 911 ft-MSL. The GSA Model was modified to simulate flood pool operations in Canyon Lake for one specified flood release rate and one specified diversion rate subject to conservation pool operations dictated by the assumptions and firm yield quoted in the previous paragraph. A fixed flood release rate of 5,000 cfs (approximating that under current guidelines) was assumed for this alternative as consideration of dam safety and flood hazard issues associated with a lesser flood release rate is beyond the scope of this study. As flood storage in Canyon Lake is federally authorized and generally occurs when water throughout the Guadalupe - San Antonio River Basin is plentiful, Trans-Texas Environmental Criteria were not applied. Water potentially available for diversion from flood storage in Canyon Lake is presented for a range of maximum diversion rates in Figure 3.44-2.

Optimization analyses considering a range of potential import pipeline diameters were performed to select the most appropriate importation facilities for this alternative based on minimum unit cost and reasonable incremental unit cost of Edwards Aquifer recharge

¹³ HDR Engineering, Inc., "Guadalupe - San Antonio River Basin Recharge Enhancement Study," Edwards Underground Water District, September, 1993.

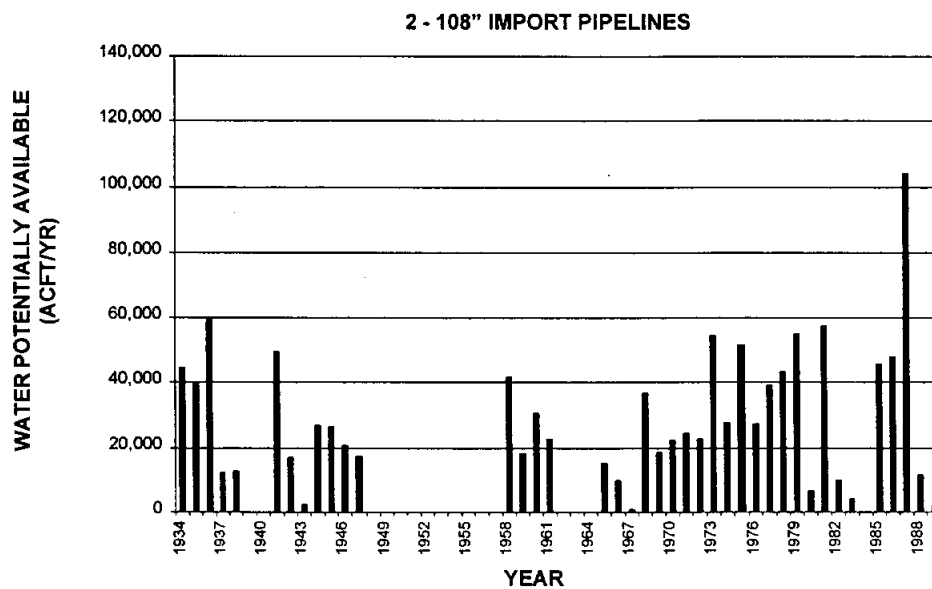
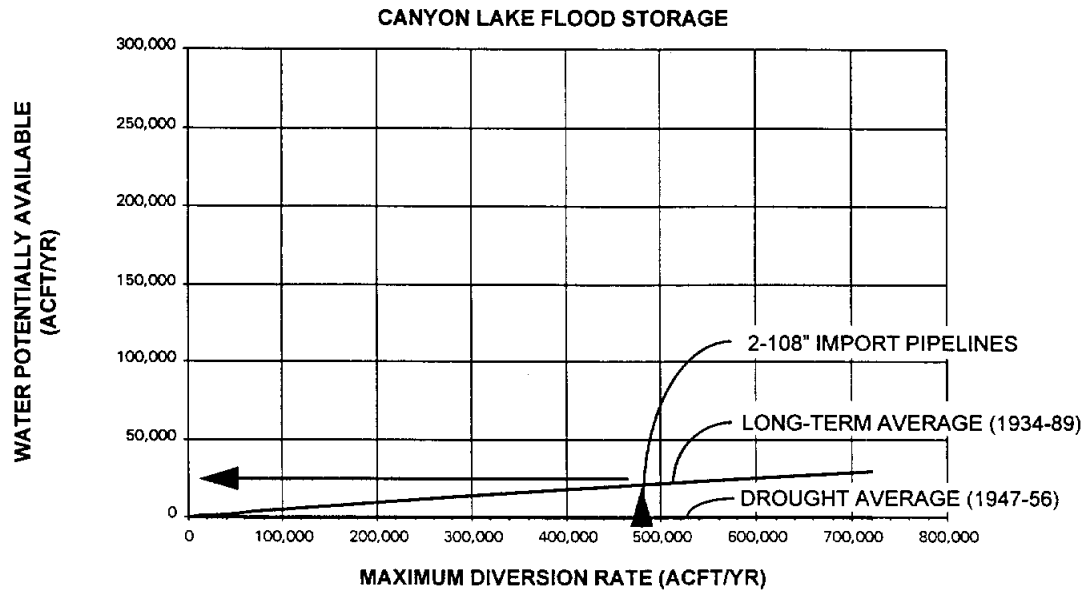

ASSUMPTIONS:

1. DIVERSIONS FOR IMPORT TO THE EDWARDS AQUIFER RECHARGE ZONE (CIBOLO CREEK) OCCURRING SIMULTANEOUSLY WITH RELEASES FROM THE FLOOD POOL OF CANYON LAKE AT A RATE OF 5,000 CFS.
2. SPRINGFLOWS RESULTING FROM FIXED EDWARDS AQUIFER PUMPAGE OF 400,000 ACFT/YR.
3. HYDROPOWER WATER RIGHTS FULLY SUBORDINATED TO CANYON LAKE.
4. UNCOMMITTED FIRM YIELD OF CANYON LAKE DIVERTED NEAR NEW BRAUNFELS.
5. RETURN FLOWS SET AT RATES OBSERVED IN 1988.
6. DROUGHT AVERAGE BASED ON CRITICAL DROUGHT PERIOD FOR CANYON LAKE WHICH BEGINS IN JULY, 1947 AND ENDS IN FEBRUARY, 1958.

TRANS TEXAS WATER PROGRAM /
WEST CENTRAL STUDY AREA



HDR Engineering, Inc.

**WATER AVAILABILITY
SUMMARY
ALTERNATIVE G-32**

FIGURE 3.44-2

enhancement. These optimization analyses (described in Section 3.44.5) resulted in the selection of two parallel 108-inch diameter import pipelines from Canyon Lake with a combined transmission capacity of about 40,000 acft/month. Water potentially available for diversion via these two 108-inch diameter pipelines would average about 21,100 acft/yr over the long-term (1934-89) and 0 acft/yr during the critical drought period for Canyon Lake (July, 1947 - February, 1958). As is apparent in Figure 3.44-2, water availability would be highly variable from year to year and severely limited or non-existent during drought periods. Water availability is somewhat limited by the assumptions that flood releases begin immediately when the lake level rises above 909 ft-MSL and would occur simultaneously with flood pool diversions. For example, given a flood release rate of 5,000 cfs and a maximum flood pool diversion rate of 660 cfs (based on two 108-inch diameter import pipelines), 88 percent of the flood storage would be released down the Guadalupe River and 12 percent would be diverted to the recharge zone via Cibolo Creek. Water potentially available subject to reduced flood release rates at Canyon Lake for a range of maximum diversion rates is presented in Appendix J.

A recharge enhancement structure located on Cibolo Creek just upstream of Bracken was considered in Alternative G-32 to improve recharge efficiency for the imported water because flood storage in Canyon Lake is likely to occur simultaneously with natural recharge events in the Cibolo Creek watershed. This recharge structure is assumed to be located at the site of Cibolo Dam No. 1 which was originally identified by Espey, Huston & Associates¹⁴ and is included in recently completed¹⁵ and ongoing studies for the Edwards Underground Water District by HDR Engineering, Inc. Assuming a storage capacity of 10,000 acft, long-term average (1934-89) recharge enhancement associated with Cibolo Dam No. 1 would be about 8,520 acft/yr¹⁶ without importation of water from Canyon Lake. Considering monthly importation from Canyon Lake flood storage averaging about 21,100 acft/yr for the 1934-89 period and accounting for about 40 cfs (2,400 acft/month) of additional recharge capacity in Cibolo Creek¹⁷ as well as available storage capacity in the recharge reservoir, additional recharge enhancement due to importation

¹⁴ Espey, Huston & Associates, Inc. (EHA), "Feasibility Study of Recharge Facilities on Cibolo Creek," Draft, Edwards Underground Water District, October, 1982.

¹⁵ HDR Engineering, Inc. (HDR), "Guadalupe - San Antonio River Basin Recharge Enhancement Study," Edwards Underground Water District, September, 1993.

¹⁶ Ibid., HDR, September, 1993.

¹⁷ Op. Cit., Espey, Huston & Associates, Inc., October, 1982.

from Canyon Lake would average about 16,100 acft/yr. Hence, about 76 percent of the Canyon Lake flood storage potentially available for diversion could contribute recharge to the Edwards Aquifer under Alternative G-32. The remaining 24 percent of Canyon Lake flood storage potentially available for diversion would not contribute to Edwards Aquifer recharge because it would occur at times when simulations indicate that there would be no available recharge capacity in Cibolo Creek and no available storage capacity at Cibolo Dam No. 1.

3.44.3 Environmental Issues

The diversion of water from flood storage at Canyon Lake to the recharge zone on Cibolo Creek would require an intake structure at Canyon Lake and two, large diameter water transmission lines about 6.7 miles long (Figure 3.44-1). The 5 mile long section of the pipeline route along FM 3159 between the City of Startzville and State Highway 46 is the same as that described as Alternative G-23B (Section 3.35, Volume 3). Alternative G-32 also includes a recharge enhancement structure on Cibolo Creek (Cibolo Dam No. 1) being studied in Phase 2 of the Guadalupe - San Antonio River Basin Recharge Enhancement Study for the Edwards Underground Water District. Although Cibolo Dam No. 1 would be in about the same location as Upper Cibolo Creek Reservoir (Alternative S-17, Section 3.48), it would be much smaller, recharge freely, and would have significantly less environmental impact.

The project area lies within central Comal County. The water transmission line traverses Brackett-Comfort-Real (shallow, undulating to steep soils over limestone or strongly cemented chalk) and Comfort-Rumple Eckrant (very shallow to moderately deep, undulating to steep and hilly soils over indurated limestone) soil associations. Both soil associations are characteristic of uplands of the Edwards Plateau.

The Edwards Plateau comprises the "Hill Country" in west-central Texas. On the east and south, the Balcones Escarpment, with its spectacular canyons, forms a distinct boundary to the Edwards Plateau. Soils are usually shallow, with a wide range of surface textures. They are underlain by limestone or caliche on the Plateau proper. The Edwards Plateau is predominantly range land, with cultivation largely confined to the deeper soils, valley bottoms, and around the larger towns. It has an excellent, but often sparse mixture of forage plants, and ranches are often stocked with combinations of cattle, sheep, and goats to make full use of the few edible plants.

Deer are abundant on much of the area and serve as a valuable source of income for many ranchers.

The most important climax grasses of the Edwards Plateau Vegetational Area¹⁸ include switchgrass, several species of bluestems and grammas, Indian grass (*Sorghastrum nutans*), Canada wild-rye (*Elymus canadensis*), curly mesquite (*Hilaria berlanderi*) and buffalo grass (*Buchloe dactyloides*). The rough, rocky areas typically support a tall or mid-grass understory and a brush overstory complex consisting primarily of live oak (*Quercus virginiana*), Texas oak (*Q. buckleyi*), shinnery oak (*Q. havardii*), juniper species (*Juniperus*) and mesquite (*Prosopis glandulosa*). Throughout the region, the brush species are generally considered as "invaders" with the climax largely grassland or open savannah, except on the steeper canyon slopes which have continually supported a dense cedar-oak thicket.

The rough, irregular surface of the Plateau is well-drained, being dissected by several perennially flowing river systems that have their origin in the large number of springs in this limestone-based region. Noteworthy is the growth of bald cypress (*Taxodium distichum*) along most of the streams and rivers. Because of the many large canyons and rugged terrain, this area is botanically of much interest and has consequently been visited by many botanical collectors. The ferns as well as many of the flowering plants are primarily lithophilous, being represented mainly by various species of lipferns (*Cheilanthes spp.*), cloak-ferns (*Notholaena spp.*), and cliff brakes (*Pellaea spp.*). Columbine (*Aquilegia canadensis*), endemics such as *Anemone edwardsensis* and wand butterfly-bush (*Buddleja racemosa*), and other species are sometimes found together on large boulders in shaded ravines along with such species as mock-orange (*Philadelphus spp.*), American smoke-tree (*Cotinus americana*), spicebush (*Benzoin aestivale*), and the endemic silver bells (*Styrax platanifolia* and *S. texana*).

McMahan, et al.,¹⁹ classified the vegetation types traversed by the proposed water import pipelines as live oak - Ashe juniper park and live oak - mesquite - Ashe juniper park. The proposed pipeline route between Canyon Lake and the outfall would be about 7.6 miles long and would follow existing roadways (FM 2673 and FM 3159). Pipeline installation, assuming a

¹⁸ Gould, F.W. 1962. Texas Plants--A Checklist and Ecological Summary. Texas Agricultural Experiment Station, Texas A&M University.

¹⁹ McMahan, C.A., R.G. Frye and K.L. Brown. 1984. The Vegetation Types of Texas Including Cropland. TPWD. Austin, TX.

construction ROW width of 140 feet, would affect a total of 128.4 acres including 32.3 acres (25.2 percent) of park, 74.6 acres (58.1 percent) of grass/shrub, and 21.5 acres (16.7 percent) of brush. An ROW 40 feet wide maintained for the life of the project would affect a total of 36.8 acres. Areas outside the maintenance ROW would be seeded in appropriate grasses and brush would be expected to significantly invade/reinvade within five to 10 years following construction.

The Hill Country Wild-Mercury (*Argythamia apheroides*), a perennial herb, is reported to occur along the proposed pipeline route southwest of the City of Startzville. The Hill Country Wild-Mercury is a rare endemic that inhabits dry sandy and rocky soil over limestone on the Edwards Plateau. It is listed as a federal candidate (C2) species and a Texas Office of Endangered Species Category V plant.

Protected species that appear most likely to be encountered during construction include The Texas salamander (*Eurycea neotenes*; reported on the Smithson, 7.5 minute quadrangle), the Texas horned lizard (*Phrynosoma cornutum*) and the Texas mock-orange (*Philadelphus texensis*). Texas mock-orange is unlikely to be encountered along the existing roadway. Potential conflicts can be avoided with appropriate habitat and important species surveys.

Comal County is within the range of the golden-cheeked warbler (*Dendroica chrysoparia*) and black-capped vireo (*Vireo atricapillus*). The golden-cheeked warbler inhabits mature oak-Ashe juniper woods for nesting. It requires strips of Ashe juniper bark for nest material. The black-capped vireo nests in dense underbrush in semi-open woodlands having distinct upper and lower stories. Because Alternative G-32 would involve construction mostly along existing ROW's, habitat for either of these birds is unlikely to be encountered. Additionally, important habitats can be avoided by selection of the pipeline route.

Canyon Lake is a water conservation and flood control reservoir located on the Guadalupe River in Comal County. Canyon Lake covers about 8,231 surface acres and stores 382,000 acft below its conservation pool elevation of 909 ft-MSL. An additional 355,000 acft can be temporarily impounded in the flood control pool located between elevations 909 ft-MSL and 943 ft-MSL.

In addition to the Guadalupe River, several smaller streams drain into Canyon Lake. These include Rebecca Creek, Schultz Creek, Potters Creek, Jentsch Creek, and Tom Creek. Like most creeks in the area, these are intermittent streams which tend to be dry in the summer,

but may have isolated pools within their streambeds during some years. At the mouths of drainages on the lake, shallow coves tend to support more wetland and mesic shoreline habitats than other areas. Emergent vegetation and broadleaf shrub in shoreline wetlands are more common along the upper shoreline away from the dam.²⁰

The Canyon Lake flood pool is primarily surrounded by residential and recreational developments including public parks. In addition to Canyon Lake itself, the Guadalupe River (above and below the lake) is a popular recreational destination that has seen substantial shoreline development in recent years. Surrounding land use is predominately rangeland with a spreading ring of suburban residential developments centered around the lake shore. Public access to scenic views and the lake shore is provided at parks operated by the U.S. Army Corps of Engineers. Private marinas, restaurants, and vacation properties allow additional lake access to tourists and area residents. Randolph Air Force Base Recreational Area and the 5th Army Retreat are located on the north shore of the lake near the dam.

In addition to the golden-cheeked warbler and black-capped vireo, a number of federally and state protected birds (bald eagle, American peregrine falcon, arctic peregrine falcon, American swallow-tailed kite, white-tailed hawk, zone-tailed hawk, interior least tern, fulvous whistling-duck, white-faced ibis, whooping crane, and wood stork), are reported to occur in Comal County (see Section 3.35.3, Volume 3 for a description of the status and habitat requirements of these birds). Alternative G-32 would be unlikely to adversely impact these birds.

Simulated streamflows below Canyon Lake without Alternative G-32 indicated monthly medians ranging from 17,106 acft to 6,849 acft (Figure 3.44-3). Monthly medians with implementation of Alternative G-32 ranged from 15,795 acft to 6,849 acft with the greatest percent reduction in monthly median being 11.6 percent. Decreased median flows were limited to the wettest months (spring). Plotting average annual streamflows with and without the project in deciles indicated that reductions in flow due to the project would be limited to the highest 50 percent of annual flows (Figure 3.44-3). Simulated streamflows for the Guadalupe River indicated that there would be no significant changes in flows at the Saltwater Barrier. Alternative

²⁰ U. S. Fish and Wildlife Service. 1990. National Wetland Inventory Map Series; Devils Backbone; Fischer, Sattler, and Smithson Valley, U.S. Geological Service Quadrangles, U.S. Department of the Interior.

GUADALUPE RIVER BELOW CANYON LAKE

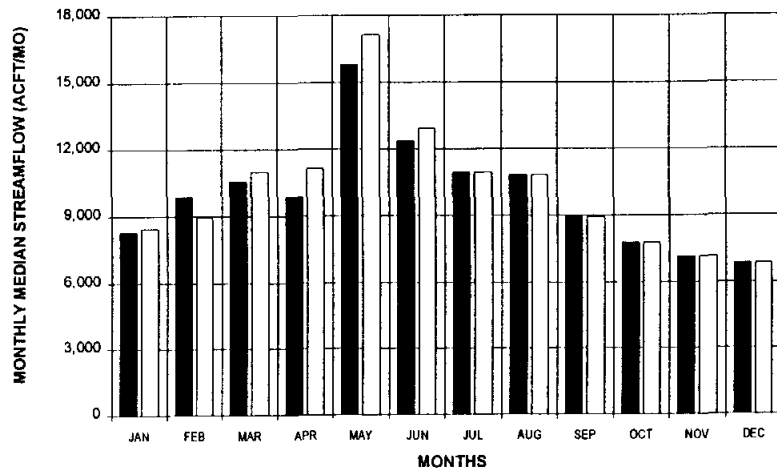

GUADALUPE RIVER BELOW CANYON LAKE

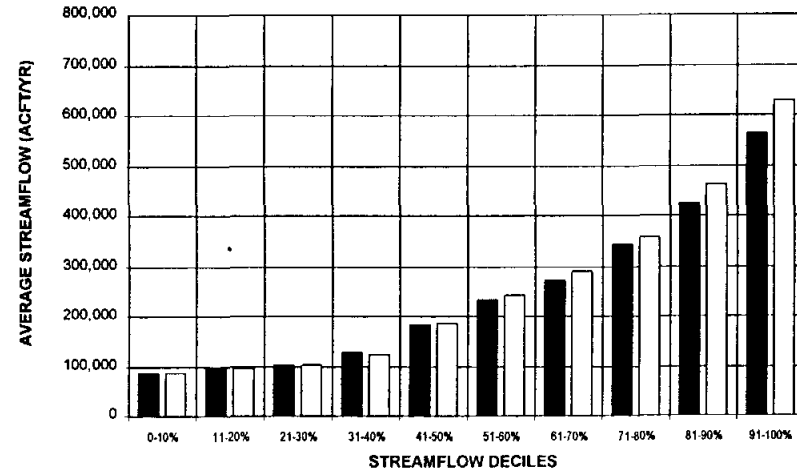

GUADALUPE RIVER BELOW SALT WATER BARRIER

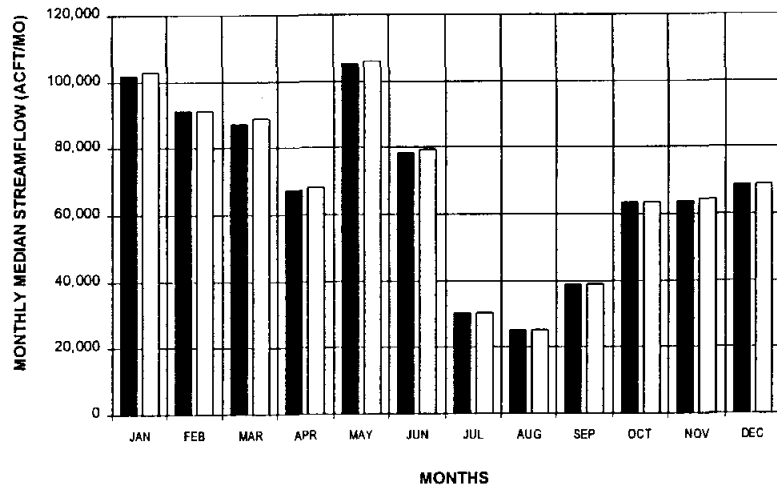

GUADALUPE RIVER BELOW SALT WATER BARRIER

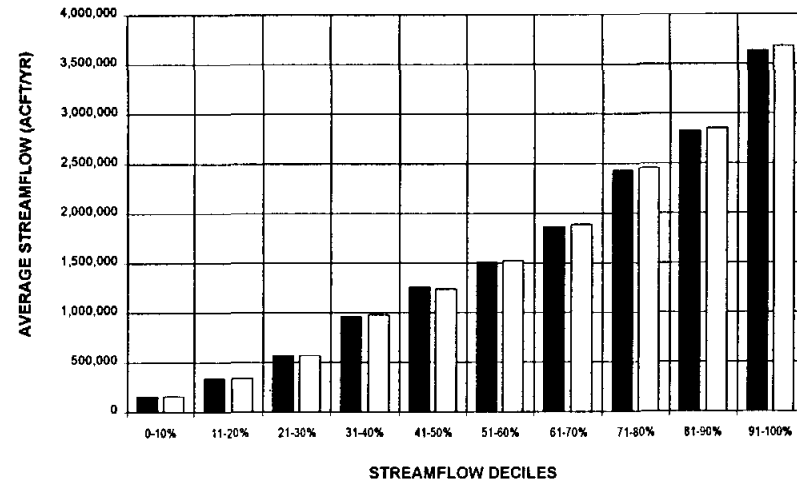

LEGEND:

- WITH PROJECT
- WITHOUT PROJECT

NOTE: STATISTICS BASED ON 1934-89 HISTORICAL PERIOD

TRANS TEXAS WATER PROGRAM /
WEST CENTRAL STUDY AREA



CHANGES IN STREAMFLOW
DIVERSION FROM CANYON LAKE
ALTERNATIVE G-32

HDR Engineering, Inc.

FIGURE 3.44-3

G-32 would not be expected to have a measurable effect on the ecology of the Guadalupe River or the Guadalupe Estuary.

Under Alternative G-32, water will be imported from the flood storage pool of Canyon Lake to Cibolo Creek for natural recharge in the streambed and/or impoundment by Cibolo Dam No. 1. It is currently estimated that Cibolo Dam No. 1 would be sized impound up to 10,000 acft and periodically inundate up to about 500 acres²¹. The terrestrial habitat impacts associated with this recharge dam will depend on the amount of clearing done, frequency of inundation, and the rapidity of pool drainage following delivery of imported water or capture of local runoff.

Because Cibolo Dam No. 1 would be designed to facilitate direct percolation into karst features (fractures, holes, and/or caves) present below the stream channel, disturbance of the local karst system and its fauna is a possibility. The fauna inhabiting these caves are usually small in both species diversity and population size, and are adapted to relatively stable physical habitats, which presumably makes them particularly sensitive to disturbances outside of the natural regime. Openings in the streambed are naturally exposed to the erosive force of flowing water, lessening the likelihood that an organized "terrestrial" community would be able to develop and persist in such a location.

Karst openings in the vicinity of Cibolo Dam No. 1 that presently experience periodic flooding may be inundated for longer periods, or experience an increase in the maximum elevation to which the water rises following a runoff event, possibly causing flow across the recharge zone. Both terrestrial and aquatic communities are extensive in the karst openings associated with the Edwards limestone, and significant threats to these habitats presently exist as a result of human activities in many areas.^{22,23} The extent of intermittently flooded karst zones that would be affected by this project, the extent to which these zones are inhabited, and how hydrologic changes might affect resident communities, is unknown.

A petition to the U.S. Fish and Wildlife Service to list as endangered or threatened nine new species of invertebrates with limited distributions in caves of northern Bexar County (see

²¹ HDR Engineering, Inc., "Guadalupe - San Antonio River Basin Recharge Enhancement Study," Edwards Underground Water District, September, 1993.

²² Ibid.

²³ Longley, G., 1981, "The Edwards Aquifer: Earth's Most Diverse Ground Water Ecosystem?" *Internatl. J. Speleol.* 11:123-128.

Table 3.9-3, Volume 2) has been filed. The petition identifies specific inhabited caves, and a study is underway to identify additional habitat areas. Cibolo Dam No. 1 is located in an area that has potential for caves containing endangered species.²⁴

Cultural resources protection on public lands in Texas, or lands affected by projects regulated under U.S. Army Corps of Engineers permits, is afforded by the Antiquities Code of Texas (Title 9, Chapter 191, Texas Natural Resource Code of 1977), the National Historic Preservation Act (PL96-515), and the Archaeological and Historic Preservation Act (PL93-291). All areas disturbed during construction will be first surveyed by qualified professionals for the presence of significant cultural resources. Additional measures to mitigate impacts may be required by the presence of significant cultural deposits that cannot be avoided.

3.44.4 Water Quality and Treatability

[To be completed in subsequent phases of the study.]

3.44.5 Engineering and Costing

For this alternative (G-32), water potentially available for diversion from Canyon Lake flood storage would be pumped to a tributary of Cibolo Creek for direct recharge and delivery to a recharge structure on Cibolo Creek (Cibolo Dam No. 1). The benefits of this project would be enhanced recharge of the Edwards Aquifer resulting in increased water supply for municipal, industrial, and irrigation use as well as enhanced springflow for recreational use and protection of endangered species. The major facilities required to implement Alternative G-32 include:

- Canyon Lake Intake and Pump Station
- Raw Water Pipeline to Cibolo Creek Tributary
- Raw Water Booster Station
- Recharge Structure

Optimization analyses were performed to select the appropriate import pipeline size for delivery of water from Canyon Lake to a tributary of Cibolo Creek. Unit costs and incremental unit costs based on the associated recharge enhancement were computed for single import pipelines ranging in diameter from 24 inches to 120 inches and other configurations consisting of

²⁴ Ibid.

two and three 108-inch parallel import pipelines. Unit cost is defined to be the Total Annual Cost associated with one import pipeline diameter divided by the resultant recharge enhancement, while incremental unit cost is defined to be the incremental cost divided by the incremental recharge enhancement obtained by comparison with cost and recharge enhancement for the next smaller diameter considered. For this alternative, the import pipeline size having the least unit cost for long-term average recharge enhancement was selected

Diversions from Canyon Lake through two 108-inch import pipelines could provide for average enhanced Edwards Aquifer recharge of about 16,100 acft/yr at a unit cost of \$740/acft/yr over the long-term (1934-89). Unit cost could not be calculated for drought conditions as there would have been no water available for diversion from Canyon Lake flood storage during the July, 1947 through February, 1958 period. These unit costs include a prorata share (based on relative Edwards Aquifer recharge enhancement attributable to importation from Canyon Lake) of the estimated capital cost of Cibolo Dam No. 1 assuming the balance costs would be paid by another sponsoring entity. Project costs and annual costs included to develop the unit costs associated with this alternative are summarized in Table 3.44-1. Information used to select the two 108-inch diameter import pipelines is illustrated in Figure 3.44-4. Key observations upon consideration of Figure 3.44-4 are summarized as follows:

- 1) With a maximum diversion rate of about 480,000 acft/yr (660 cfs), two 108-inch diameter import pipelines could enhance Edwards Aquifer recharge by a long-term average amount of about 16,100 acft/yr.
- 2) On the basis of long-term average unit cost for importation and recharge facilities, two 108-inch diameter import pipelines (\$742/acft/yr) were chosen based on long-term average recharge enhancement.
- 3) If the specified Canyon Lake flood release rate of 5,000 cfs could be reduced, long-term average water available for diversion could be increased substantially. The extent to which such increased availability could be converted to Edwards Aquifer recharge enhancement, however, would be significantly limited by the availability of storage capacity at Cibolo Dam No. 1. Recharge enhancement during drought would remain non-existent regardless of Canyon Lake flood release rate.

general assumptions for computation of available yield under this alternative, simulated historical streamflows without the project include the springflows resulting from fixed Edwards Aquifer pumpage of 543,677 acft/yr and full utilization of existing water rights and contracts.

Modeling flows at Lake Dunlap indicated a decrease in annual median flows of from 287,948 acft/yr without Alternative G-33 to 230,738 acft/yr with implementation of the project, a 20 percent decrease. Monthly median flows without implementation of Alternative G-33 ranged from 26,144 acft to 7,247 acft, while monthly median flows with the project ranged from 22,410 acft to 4,880 acft. Monthly median decreases ranged from 40.7 percent to 10.9 percent. Decreases in median flows were spread fairly evenly throughout months of the year with the greatest percent decreases generally being in low flow months. Similarly, estimated annual average flows decreased 2.6 percent (from 783,423 acft/yr to 762,872 acft/yr) in the highest decile and 88.5 percent (from 32,206 acft/yr to 3,715 acft/yr) in the lowest decile. The considerable reductions in projected streamflow below Lake Dunlap may adversely affect some biological communities downstream, especially during low flow months. However, about 70 percent of the Guadalupe River downstream from Lake Dunlap and above the San Marcos River consists of lentic habitats (impoundments) that might be expected to be less sensitive to decreased flows than lotic (flowing) habitat.

Modeling flows in the Guadalupe River at the Saltwater Barrier indicated increased annual median flows of from 1.22 million acft/yr without Alternative G-33 to 1.44 million acft/yr with the project, an 18 percent increase. This increase in flows at the Saltwater Barrier is due to enhanced springflow resulting from the simulated reduction in Edwards Aquifer pumpage from 543,677 acft/yr to 400,000 acft/yr. Monthly medians without the project ranged between 96,754 acft and 16,960 acft, while monthly medians with implementation of Alternative G-33 ranged between 117,757 acft and 40,694 acft. Percent increases in monthly medians ranged between 140 percent and 11.8 percent. Because the increased flows with the project were spread fairly evenly among high and low flows, the highest percent increases occurred in the lowest deciles. Reduced pumping of the Edwards Aquifer would result in increased springflow, instream flows in the Guadalupe River below the San Marcos River, and freshwater inflows to the Guadalupe Estuary (especially during the drier summer months). Increased springflows due to reduced Edwards Aquifer pumpage would be expected to have a generally favorable effect on species and habitat

near Comal and San Marcos Springs, along the San Marcos and Guadalupe Rivers, and in the Guadalupe Estuary.

Instream flow studies should be conducted in the reaches below Lake Dunlap in order to evaluate the potential affects on the general ecology of the river and on Cagle's map turtle (*Graptemys cagleii*), Guadalupe bass (*Micropterus treculi*), and blue sucker (*Cyprinostomus elongatus*) which are federal candidate species. In Texas, the blue sucker is listed as threatened. Cagle's map turtle, Guadalupe bass, and blue sucker range from the Edwards Plateau, through the Blackland Prairie, and to the Coastal Plain in the Guadalupe River. The Guadalupe bass may occur in Lake Dunlap, however, it is better adapted to flowing water and is often found near riffles feeding on insects. The blue sucker (a candidate for federal protection) is a large river fish that could occur in Guadalupe County. However, Hubbs, et al,³⁰ does not report the blue sucker as having been collected from the upper Guadalupe River.

Waters imported from the Guadalupe River at Lake Dunlap are to be delivered to a proposed series of small recharge enhancement dams located primarily in northern Bexar County. The terrestrial habitat impacts associated with these recharge dams will depend on the amount of clearing done, frequency of inundation, and the rapidity of pool drainage following delivery of imported water or capture of local runoff.

Because these recharge dams are designed to facilitate direct percolation into karst features (fractures, holes, and/or caves) present below the stream channel, disturbance of the local karst system and its fauna is a possibility. The fauna inhabiting these caves are usually small in both species diversity and population size, and are adapted to relatively stable physical habitats, which presumably makes them particularly sensitive to disturbances outside of the natural regime. The results of the investigation of the karst fauna in northern Bexar County, however, seem to indicate that caves with biological communities have not been encountered in streambeds there³¹. Openings in the streambed are naturally exposed to the erosive force of flowing water, lessening the likelihood that an organized "terrestrial" community would be able to develop and persist in such a location.

³⁰ Hubbs, C., R.J. Edwards, G.P. Garrett, 1991. An Annotated Checklist of the Freshwater Fishes of Texas, With Keys to Identification of Species. Texas Journal of Science, 43(4), 1-56.

³¹ Elliot, W.R., 1993, "Cave Fauna Conservation in Texas," Proceedings of the 1991 National Cave Management Symposium, Bowling Green, Kentucky, American Cave Conservation Association, Horse Cave, Kentucky.

Karst openings in the vicinity of these proposed recharge dams that presently experience periodic flooding may be inundated for longer periods, or experience an increase in the maximum elevation to which the water rises following a runoff event, possibly causing flow across the recharge zone. Both terrestrial and aquatic communities are extensive in the karst openings associated with the Edwards limestone, and significant threats to these habitats presently exist as a result of human activities in many areas including northern Bexar County^{32,33}. The extent of intermittently flooded karst zones that would be affected by the recharge dams, the extent to which these zones are inhabited, and how hydrologic changes might affect resident communities, is unknown.

Numerous caves in the vicinity of the proposed recharge dams in northern Bexar County have been explored and the faunas have been inventoried.^{34, 35} Government Canyon Bat Cave supports a population of Cave Myotis bats (*myotis velifer*). Additionally, several of the caves support cave beetles, including *Rhadina infernalis*. There are also caves in the vicinity of San Geronimo Creek (northeastern Medina County), but none have been explored. In the vicinity of Culebra Creek, lack of access to the property has prevented a search for caves. No caves have been identified in the vicinity of Deep or Limekiln Creeks.

A petition to the U.S. Fish and Wildlife Service to list as endangered or threatened nine new species of invertebrates with limited distributions in caves of northern Bexar County, including the *Rhadina* beetle has been filed (see Table 3.9-3, Volume 2). The petition identifies specific inhabited caves, including Government Canyon Bat Cave, and a study is underway to identify additional habitat areas. All of the proposed recharge dams are in areas that have potential for caves containing endangered species³⁶.

Government Canyon Bat Cave is located in the immediate vicinity of the potential recharge dam site on Government Creek. Although the known opening of this cave is located well above the impoundment elevation, the depth to which *Cicurina* (Troglobitic spider) habitat

³² Ibid.

³³ Longley, G., 1981, "The Edwards Aquifer: Earth's Most Diverse Ground Water Ecosystem?" Internatl. J. Speleol. 11:123-128.

³⁴ Veni, G., Personal Communication, April, 22, 1994.

³⁵ Elliott, W., Personal Communication, November 21, 1995.

³⁶ Veni, G., Personal Communication, April, 22, 1994.

extends is not known, and additional site surveys would be required to determine whether it might be affected by an increase in the duration of inundation events, or by an increase in the maximum inundation elevation within the cave. On-site surveys of the reservoir and surrounding areas and mitigation or relocation of the recharge dam may be required if caves with protected species are found and will be affected by project development.

Government Canyon, including the Government Canyon Bat Cave site, is the location of a new state park. The Government Canyon State Park plan includes environmental resource preservation, a preserve for nesting Golden-cheeked warblers and Black-capped vireos, and some recreational facilities. Although dam construction may be a concern, natural recharge in the canyon (including water imported from the Guadalupe River via Medina Lake) may not conflict with preserving the environmental resources of the area or the park development plan.

The Government Creek area is known to contain numerous prehistoric sites and a 17th century Spanish colonial trail. Other recharge sites may contain similar cultural resources. Cultural resources protection on public lands in Texas, or lands affected by projects regulated under U.S. Army Corps of Engineers permits, is afforded by the Antiquities Code of Texas (Title 9, Chapter 191, Texas Natural Resource Code of 1977), the National Historic Preservation Act (PL96-515), and the Archaeological and Historic Preservation Act (PL93-291). All areas disturbed during construction will be first surveyed by qualified professionals for the presence of significant cultural resources. Additional measures to mitigate impacts may be required by the presence of significant cultural deposits that cannot be avoided.

3.45.4 Water Quality and Treatability

[To be completed in subsequent phases of the study.]

3.45.5 Engineering and Costing

For this alternative (G-33), water potentially available for diversion from Lake Dunlap would be pumped to a series of recharge enhancement dams located primarily in northwestern Bexar County. The benefits of this project would be enhanced recharge of the Edwards Aquifer resulting in increased water supply for municipal, industrial, and irrigation use as well as enhanced

springflow for recreational use and protection of endangered species. The major facilities required to implement Alternative G-33 include:

- Reservoir Intake and Pump Station
- Raw Water Pipeline to Recharge Zone
- Raw Water Booster Stations
- Recharge Structures

Optimization analyses were performed to select the appropriate import pipeline size for delivery of water from Lake Dunlap to the recharge zone as well as the appropriate number of structures necessary to ensure recharge of all imported water. Unit costs and incremental unit costs based on the associated recharge enhancement were computed for import pipelines ranging in diameter from 24 inches to 120 inches. Unit cost is defined to be the Total Annual Cost associated with one import pipeline diameter divided by the resultant recharge enhancement, while incremental unit cost is defined to be the incremental cost divided by the incremental recharge enhancement obtained by comparison with cost and recharge enhancement for the next smaller diameter. Import pipeline size was generally selected in accordance with the following criteria: 1) Pipeline diameter greater than or equal to that having the least unit cost for long-term average recharge enhancement; and 2) Largest pipeline diameter with a reasonable incremental unit cost for drought average recharge enhancement.

Diversions from Lake Dunlap (comprised of enhanced springflow, unutilized water rights, and unappropriated streamflow) through an 84-inch import pipeline could provide average enhanced Edwards Aquifer recharge of about 123,200 acft/yr at a unit cost of \$264/acft/yr over the long-term (1934-89) and of about 70,300 acft/yr at a unit cost of \$389/acft/yr during drought (1947-56). Project costs and annual costs included to develop the unit costs associated with this alternative are summarized in Table 3.45-1. Information used to select the 84-inch diameter import pipeline from the Guadalupe River to the recharge zone is illustrated in Figure 3.45-4. Key observations upon consideration of Figure 3.45-4 are summarized as follows:

1. With a maximum diversion rate of about 139,000 acft/yr (190 cfs), an 84-inch diameter import pipeline could enhance Edwards Aquifer recharge by a long-term average amount of about 123,200 acft/yr and a drought average amount of about 70,300 acft/yr. Based on reduction of Edwards Aquifer pumpage to 400,000 acft/yr, little additional recharge enhancement could be obtained during drought with larger diameter import pipelines.

Table 3.45-1
Cost Estimate For Guadalupe River Diversion Near Lake Dunlap to Recharge Zone
With Enhanced Springflow, Water Rights Transfer, and Unappropriated Flow (G-33)
(Mid 1994 Prices)

Item	Diversion to Recharge Zone	
	Long-Term Average ¹	Drought Average ²
Capital Costs		
Transmission and Pumping	\$104,715,000	
Delivery System	<u>19,642,000</u>	
Total Capital Cost	\$124,357,076	
Engineering, Contingencies, and Legal Costs	38,761,000	
Land Acquisition	1,139,000	
Environmental Studies and Mitigation	3,959,000	
Interest During Construction	<u>7,935,000</u>	
Total Project Cost	\$176,151,000	
Annual Costs		
Annual Debt Service	\$ 16,502,000	\$ 16,502,000
Annual Operation and Maintenance	2,213,000	2,213,000
Purchase of Water ³	1,787,000	1,787,000
Annual Power Cost	<u>12,085,000</u>	<u>6,859,000</u>
Total Annual Cost	\$ 32,587,000	\$ 27,361,000
Available Project Yield (acft/yr)	123,200	70,300
Annual Cost of Water (\$/acft/yr)	\$ 264	\$ 389

¹ Long-term average based on 1934-89 historical period.

² Drought average based on 1947-56 historical period.

³ Cost for purchase of water assumed to be \$53/acft/yr based on drought average diversions from Lake Dunlap under existing water rights. No purchase costs included for diversion of enhanced springflow or unappropriated water.

However, if Edwards Aquifer pumpage is restricted to amounts less than 400,000 acft/yr during drought, then a larger diameter import pipeline could produce greater recharge enhancement.

2. On the basis of long-term average unit cost for importation and recharge facilities, a 96-inch diameter import pipeline (\$260/acft/yr) could be chosen based on long-term average recharge enhancement.

GUADALUPE RIVER BELOW LAKE DUNLAP

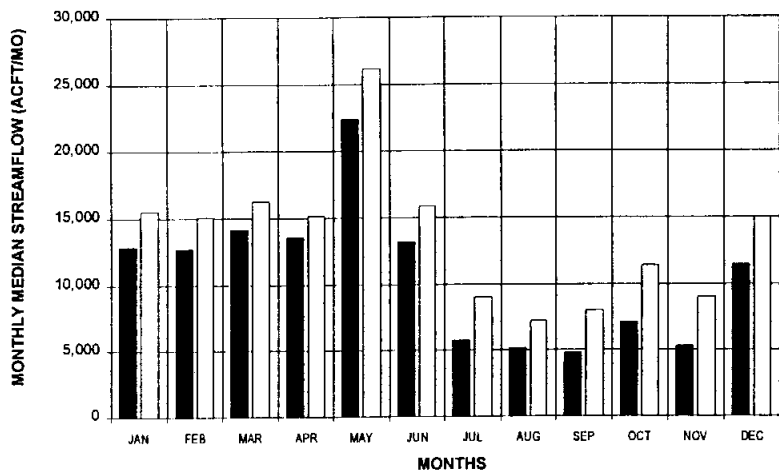

GUADALUPE RIVER BELOW LAKE DUNLAP

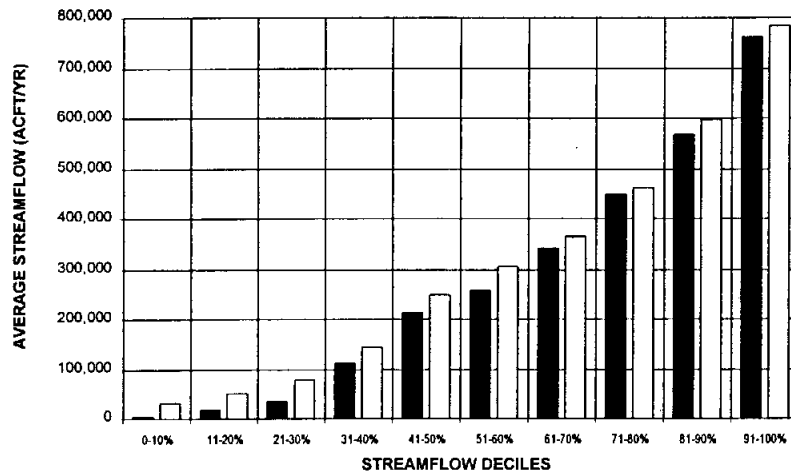

GUADALUPE RIVER BELOW SALTWATER BARRIER

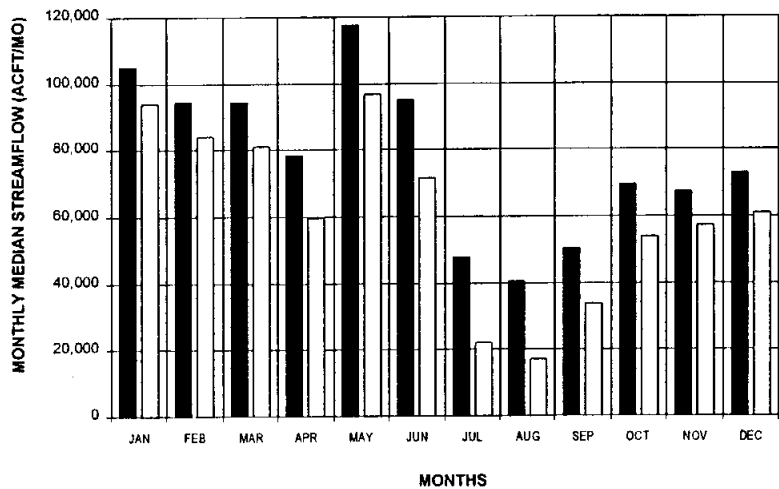

GUADALUPE RIVER BELOW SALTWATER BARRIER

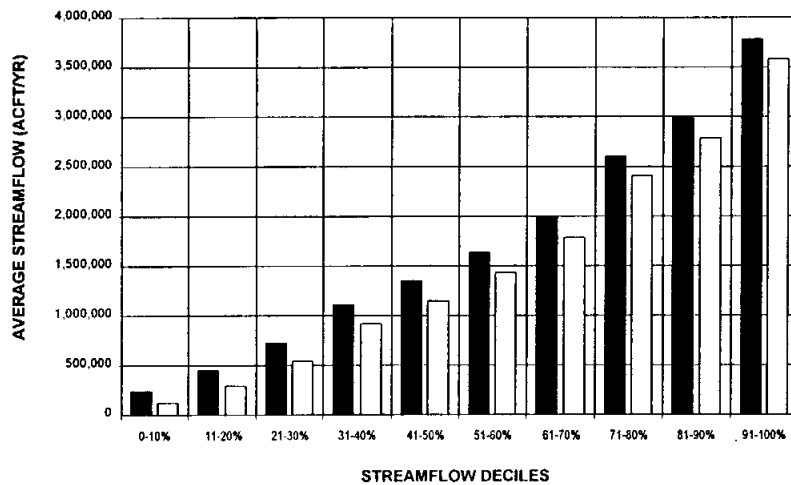

LEGEND:

- WITH PROJECT (EDWARDS AQUIFER PUMPAGE = 400,000 ACFT/YR)
- WITHOUT PROJECT (EDWARDS AQUIFER PUMPAGE = 543,677 ACFT/YR)

NOTE: STATISTICS BASED ON 1934-89 HISTORICAL PERIOD

TRANS TEXAS WATER PROGRAM / WEST CENTRAL STUDY AREA



HDR Engineering, Inc.

CHANGES IN STREAMFLOW DIVERSION FROM LAKE DUNLAP ALTERNATIVE G-33

FIGURE 3.45-3

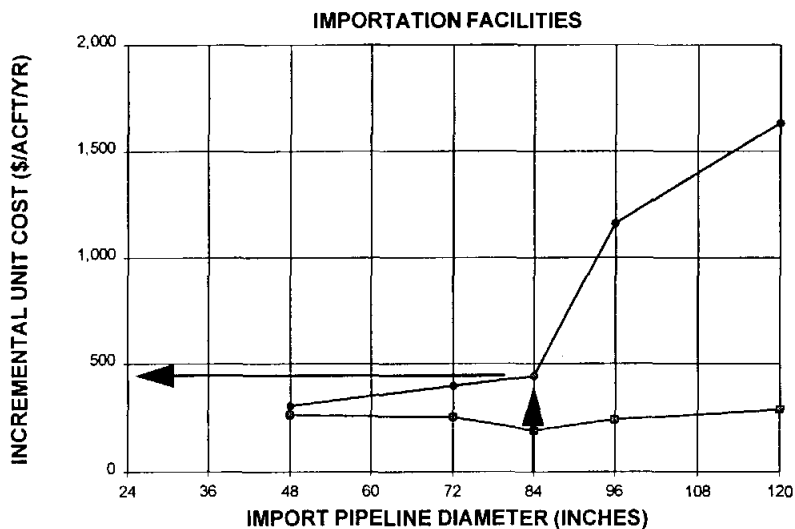
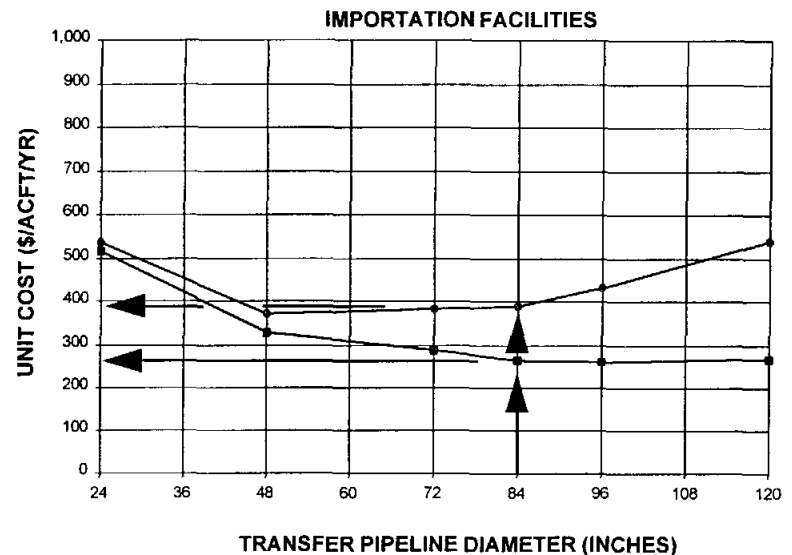
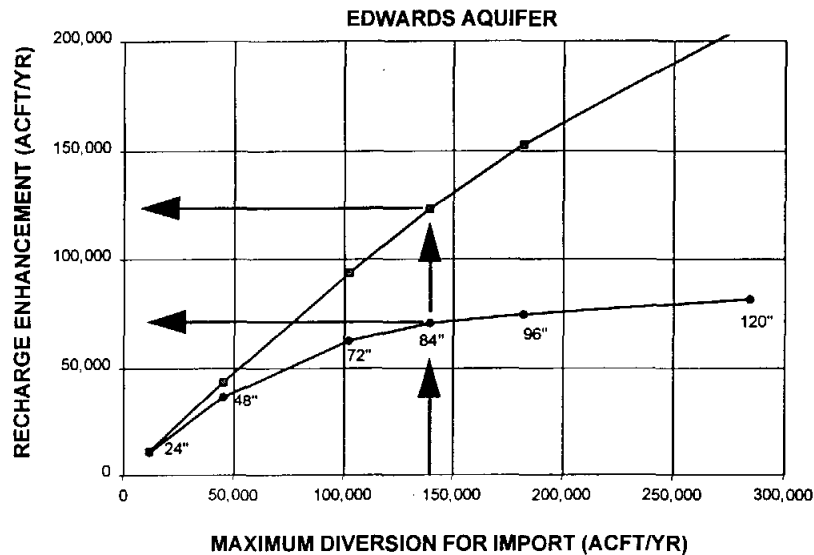

ASSUMPTIONS:

1. DIVERSIONS UNDER ENHANCED SPRINGFLOW, WATER RIGHTS UNUTILIZED IN 1989, AND UNAPPROPRIATED STREAMFLOW FROM LAKE DUNLAP FOR IMPORT TO THE EDWARDS AQUIFER RECHARGE ZONE IN NORTHERN BEXAR COUNTY.
2. COST OF RECHARGE ENHANCEMENT STRUCTURES INCLUDED TO ENSURE THAT IMPORTED WATERS ENTER THE EDWARDS AQUIFER.
3. ENHANCED SPRINGFLOWS RESULTING FROM SIMULATED REDUCTION OF FIXED EDWARDS AQUIFER PUMPAGE FROM 543,677 ACFT/YR (1989) TO 400,000 ACFT/YR.
4. HYDROPOWER WATER RIGHTS FULLY SUBORDINATED TO CANYON LAKE.
5. RETURN FLOWS SET AT RATES OBSERVED IN 1989.

LEGEND:

- LONG-TERM AVERAGE (1934-89)
- DROUGHT AVERAGE (1947-56)



HDR Engineering, Inc.

TRANS TEXAS WATER PROGRAM / WEST CENTRAL STUDY AREA

OPTIMIZATION SUMMARY ALTERNATIVE G-33

FIGURE 3.45-4

3. Considering incremental unit cost for importation facilities based on drought average recharge enhancement, an 84-inch diameter import pipeline was selected. "Up-sizing" to a 96-inch or larger diameter would not be recommended, based on the sources of water considered, as additional drought average recharge enhancement costs more than \$1,100/acft/yr. However, consideration of a larger diameter import pipeline may be warranted in future studies if, during drought conditions, aquifer pumpage is restricted to amounts less than 400,000 acft/yr or other sources of water are made available.
4. If a portion of the uncommitted firm yield of Canyon Lake were made available in combination with these water sources, this alternative could produce a firm yield well in excess of the drought average recharge enhancement reported herein.

3.45.6 Implementation Issues (G-33)

Lake Dunlap Intake

1. It will be necessary to obtain these permits:
 - a. TNRCC Water Right permit.
 - b. U.S. Army Corps of Engineers Sections 10 and 404 dredge and fill permits for the intake.
 - c. GLO Easement for use of state-owned land.
 - d. Coastal Coordination Council review.
 - e. GBRA modification or construction permit.
2. Permitting, at a minimum, will require these studies:
 - a. Environmental studies.
 - b. Cultural resource studies.
3. Land will need to be acquired through either negotiations or condemnation.

Requirements Specific to Diversion of Water from Guadalupe River

1. Necessary permits:
 - a. TNRCC permit to divert enhanced springflows.
 - b. Existing water rights permits will need to be amended subsequent to negotiations with each water right owner to allow for an additional point of diversion at Lake Dunlap.
 - c. TNRCC permit to divert unappropriated water.
 - d. TNRCC Interbasin Transfer Approval.
 - e. TNRCC authorization to use Guadalupe River water for recharge purposes in the San Antonio River Basin through the use of recharge dams.
2. Permitting will require these studies:
 - a. Instream flow issues and impact.
 - b. Environmental studies.
 - c. Bay and Estuary inflow impact.
3. Agreements with water right permit owners for use and payment for water diverted under existing permits.

Requirements Specific to Pipelines

1. Necessary permits:
 - a. U.S. Army Corps of Engineers Sections 10 and 404 dredge and fill permits for stream crossings.
 - b. GLO Sand and Gravel Removal permits.
 - c. Coastal Coordination Council review.
 - d. TPWD Sand, Gravel, and Marl permit.
2. Right-of-way and easement acquisition.
3. Crossings:
 - a. Highways and railroads.
 - b. Creeks and rivers.
 - c. Other utilities.

Requirements Specific to Surface Recharge Structures

1. Detailed field investigation of each potential recharge site to determine natural and expected recharge rates.
2. For water imported to the recharge zone: water compatibility testing and assessment of treatment needs (if any), including biological and chemical characteristics.
3. Necessary permits could include:
 - a. TNRCC Water Right and Storage permits.
 - b. U.S. Army Corps of Engineers Sections 10 and 404 dredge and fill permits.
 - c. GLO Sand and Gravel Removal permits.
 - d. TPWD Sand, Gravel, and Marl permit.
4. Permitting, at a minimum, will require these studies:
 - a. Determination of impact plans for parkland, wildlife preserves, and other conservation programs.
 - b. Study of impact on karst geology organisms from a sustained recharge program.
 - c. Other environmental studies.

Table 3.44-1
Cost Estimate for Diversion from Canyon Lake Flood Storage
to Recharge Zone via Cibolo Creek (G-32)
(Mid 1994 Prices)

Item	Diversion to Recharge Zone	
	Long-Term Average ¹	Drought Average ²
Capital Costs		
Transmission and Pumping	\$ 68,126,000	
Cibolo Dam No. 1	<u>9,097,000</u> ³	
Total Capital Cost	\$ 77,223,000	
Engineering, Contingencies, and Legal Costs	21,266,000 ⁴	
Land Acquisition	147,000 ⁴	
Environmental Studies and Mitigation	147,000 ⁴	
Interest During Construction	<u>3,587,000</u> ⁴	
Total Project Cost	\$102,370,000	
Annual Costs		
Annual Debt Service	\$ 9,592,000	
Annual Operation and Maintenance	1,226,000	
Annual Power Cost	<u>1,102,000</u>	
Total Annual Cost	\$11,920,000	
Available Project Yield (acft/yr)	16,100	0 ⁵
Annual Cost of Water (\$/acft/yr)	\$ 740	N/A

¹ Long-term average based on 1934-89 historical period.

² Drought average based on critical period for Canyon Lake, June, 1947--February, 1958.

³ Total project cost of Cibolo Dam No. 1 is approximately \$13,900,000. Capital cost reported here is pro-rated based on the ratio of enhanced recharge resulting from Canyon Lake diversion to total enhanced recharge. It is assumed that the balance of Cibolo Dam No. 1 costs would be paid by another sponsoring agency.

⁴ Costs for pump stations and pipeline only. Comparable costs for Cibolo Dam No. 1 included in capital cost.

⁵ No flood storage in Canyon Lake during drought.

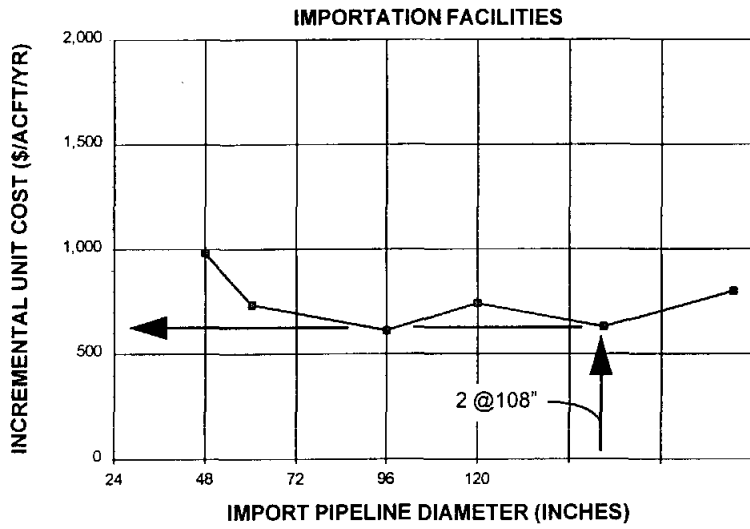
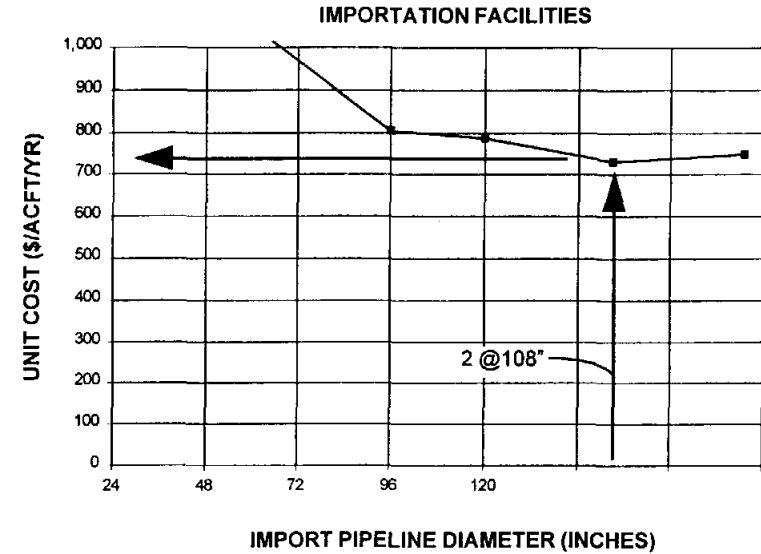
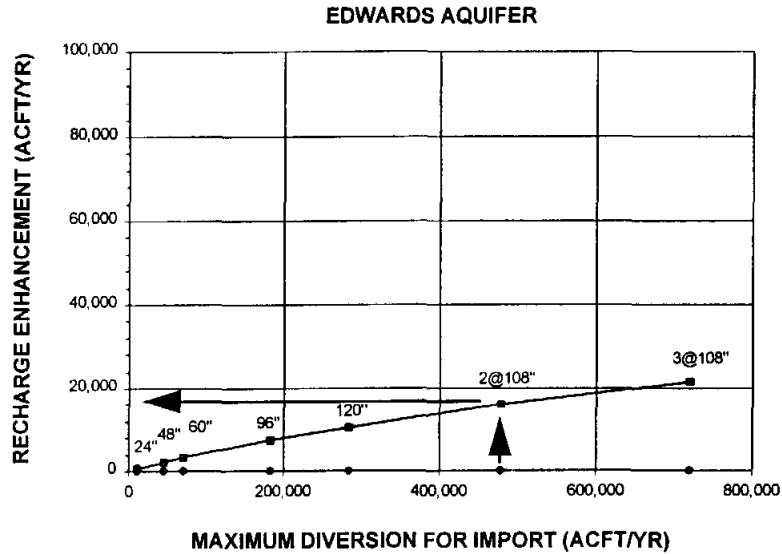

ASSUMPTIONS:

1. DIVERSIONS FOR IMPORT TO THE EDWARDS AQUIFER RECHARGE ZONE (CIBOLO CREEK) OCCURRING SIMULTANEOUSLY WITH RELEASES FROM THE FLOOD POOL OF CANYON LAKE AT A RATE OF 5,000 CFS.
2. RECHARGE ENHANCEMENT IS AMOUNT RESULTING FROM IMPORTATION IN EXCESS OF THAT WHICH WOULD OCCUR WITH THE CONSTRUCTION OF CIBOLO DAM NO. 1 AT A CAPACITY OF 10,000 ACFT ON CIBOLO CREEK.
3. SPRINGFLOWS RESULTING FROM FIXED EDWARDS AQUIFER PUMPAGE OF 400,000 ACFT/YR.
4. HYDROPOWER WATER RIGHTS FULLY SUBORDINATED TO CANYON LAKE.
5. RETURN FLOWS SET AT RATES OBSERVED IN 1988.

LEGEND:

- LONG-TERM AVERAGE (1934-89)
- DROUGHT AVERAGE (1947-56)

TRANS TEXAS WATER PROGRAM /
WEST CENTRAL STUDY AREA



**OPTIMIZATION SUMMARY
ALTERNATIVE G-32**

3.44.6 Implementation Issues

Requirements Specific to Diversion of Water From Canyon Lake

1. Necessary permits:
 - a. TNRCC permit to divert unappropriated water.
 - b. TNRCC Interbasin Transfer Approval.
 - c. TNRCC authorization to use Cibolo Creek and its tributaries to deliver Guadalupe River water for recharge purposes to the San Antonio River Basin.
 - d. U.S. Army Corps of Engineers (USCE) Sections 10 and 404 dredge and fill permits for the intake structure.
2. Permitting will require these studies:
 - a. Instream flow issues and impact.
 - b. Environmental studies.
3. Agreements with USCE and, possibly, Guadalupe-Blanco River Authority to construct and operate an intake and pump station at Canyon Lake to transfer Guadalupe River water to the recharge zone.
4. Agreement with GBRA regarding changes in the number of days Canyon Lake remains in the flood pool as this affects operations and maintenance costs shared by GBRA and USCE.

Requirements Specific to Pipelines

1. Necessary permits:
 - a. U.S. Army Corps of Engineers Sections 10 and 404 dredge and fill permits for stream crossings.
 - b. GLO Sand and Gravel Removal permits.
 - c. Coastal Coordination Council review.
 - d. TPWD Sand, Gravel, and Marl permit.
2. Right-of-way and easement acquisition.
3. Crossings:
 - a. Highways and railroads.
 - b. Creeks and rivers.
 - c. Other utilities.

Requirements Specific to Surface Recharge Structures

1. Detailed field investigation of potential recharge site on Cibolo Creek to determine natural and expected recharge rates.
2. For water imported to the recharge zone: water compatibility testing and assessment of treatment needs (if any), including biological and chemical characteristics.
3. Necessary permits could include:
 - a. TNRCC Water Right and Storage permits.
 - b. U.S. Army Corps of Engineers Sections 10 and 404 dredge and fill permits.
 - c. GLO Sand and Gravel Removal permits.
 - d. TPWD Sand, Gravel, and Marl permit.

4. Permitting, at a minimum, will require these studies:
 - a. Determination of impact plans for parkland, wildlife preserves, and other conservation programs.
 - b. Study of impact on karst geology organisms from a sustained recharge program.
 - c. Other environmental studies.
 - d. Studies of potential water level changes at Natural Bridge Caverns and Bat Cave and studies to determine if impacts are significant.

THIS PAGE LEFT INTENTIONALLY BLANK

3.45 Guadalupe River Diversion Near Lake Dunlap to Recharge Zone with Enhanced Springflow, Water Rights Transfer, and Unappropriated Flow (G-33)

3.45.1 Description of Alternative

Alternative G-33 includes the diversion of water from Lake Dunlap on the Guadalupe River below Comal Springs and importation of this water for enhancement of Edwards Aquifer recharge. An important objective of this alternative is to illustrate the concept that enhanced springflow resulting from potential reductions in pumpage could be reclaimed below the springs by Edwards Aquifer users and subsequently used for enhancement of Edwards Aquifer recharge. With respect to water potentially available for diversion, this alternative includes three primary sources: 1) Enhanced springflow resulting from a theoretical reduction in overall Edwards Aquifer pumpage from that observed in calendar year 1989 (543,677 acft)²⁵ to 400,000 acft/yr; 2) The unutilized portion (based on calendar year 1989) of existing water rights throughout the Guadalupe - San Antonio River Basin; and 3) Unappropriated streamflow subject to senior water rights and Trans-Texas Environmental Criteria. As shown in Figure 3.45-1, the major facilities associated with this alternative include a surface water intake structure and pump station at Lake Dunlap, an import pipeline about 46 miles in length, and a series of small recharge enhancement dams located primarily in northwestern Bexar County.

Alternatives involving diversions from Lake Dunlap considered previously in the Trans-Texas Water Program are briefly summarized as follows. Alternative G-14 (Section 3.17, Volume 2) describes the availability of unappropriated water at Lake Dunlap and a finding that no firm yield exists without provisions for a surface reservoir or aquifer storage. A variation of Alternative G-14 considering a small off-channel reservoir and delivery to the recharge zone (Section 3.19, Volume 2), could produce drought average (1947-56 period) recharge enhancement of about 3,500 acft/yr based solely on unappropriated streamflow. Purchase of 10,000 acft/yr to 15,000 acft/yr from the uncommitted firm yield of Canyon Lake for diversion at Lake Dunlap was evaluated in Alternative G-15 (Section 3.20, Volume 2). Most recently, diversions from Lake Dunlap were evaluated as a component of a comprehensive water management plan proposed by the San Antonio Water System (Section 3.40, Volume 3) resulting

²⁵ TWDB, Personal Communication, August 22, 1995.

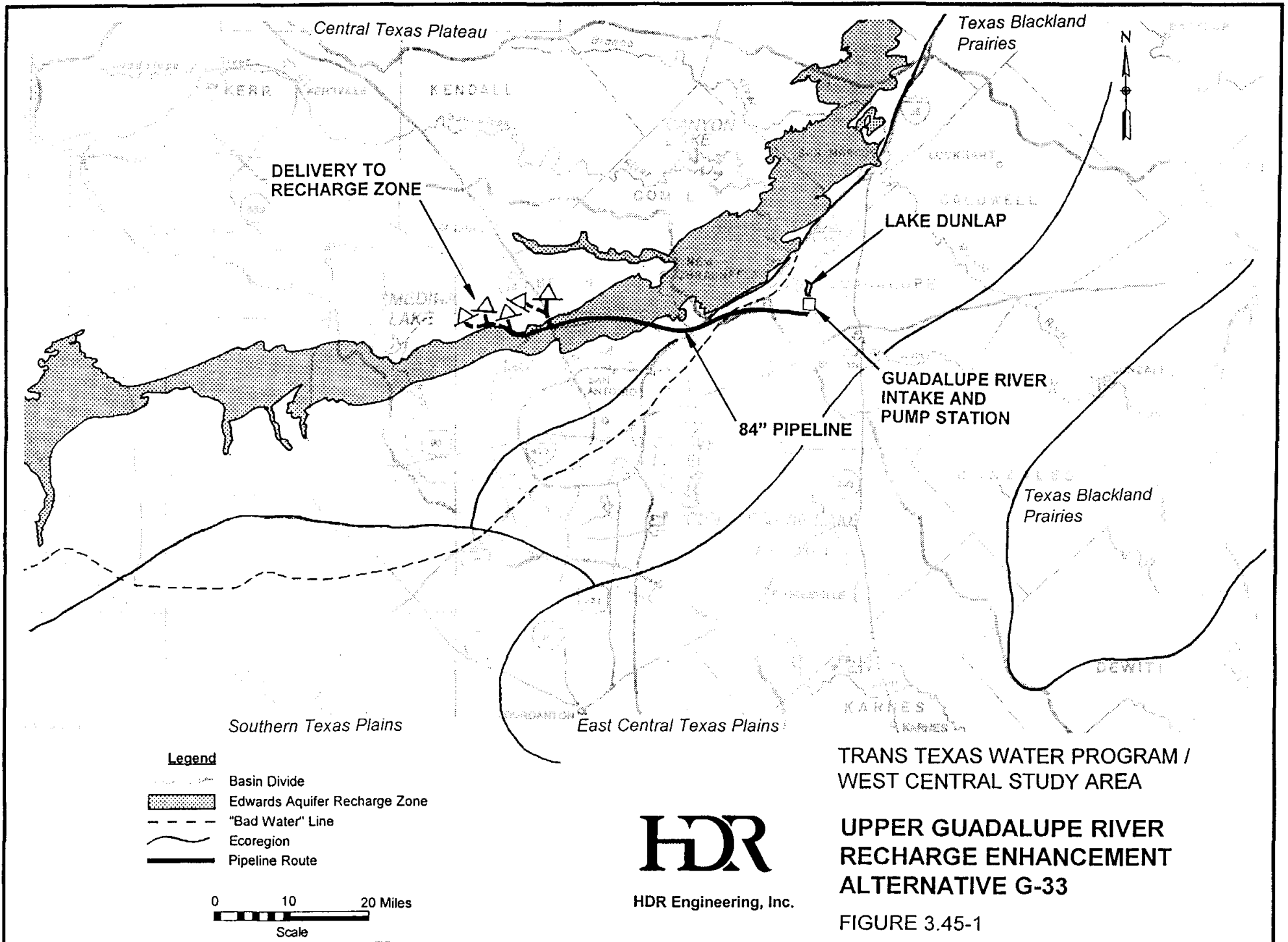

in an available yield of about 78,600 acft/yr based on water rights transfers combined with purchase of uncommitted firm yield of Canyon Lake. While Alternative G-33 does not include purchase of Canyon Lake water, it does consider diversion of all other sources of water previously considered plus the enhanced springflow resulting from potential Edwards Aquifer pumpage reductions.

3.45.2 Available Yield

The available yield for Alternative G-33 would be realized in the form of enhanced Edwards Aquifer recharge obtained through the diversion of water from the Guadalupe River at Lake Dunlap below Comal Springs. Water potentially available for diversion at Lake Dunlap (under assumptions presently applicable only to this alternative) is comprised of any enhanced springflow, flow committed to existing water rights (permitted, but unutilized in calendar year 1989), and unappropriated streamflow. The procedures and assumptions pertinent to the computation of water potentially available from each of these sources are described in the following subsections. For additional information regarding other pumpage scenarios or diversions below San Marcos Springs, refer to Appendix J.

Enhanced Springflow

Approximations of increases in springflow resulting from potential reductions in Edwards Aquifer pumpage from the amount observed in calendar year 1989 (543,677 acft) were obtained using the Edwards Aquifer Model developed and maintained by the Texas Water Development Board (TWDB).²⁶ In response to a request from the Policy Management Committee for the West Central Study Area, TWDB staff applied the aquifer model to simulate springflows resulting from a fixed annual Edwards Aquifer pumpage of 543,677 acft. Simulated springflows from the TWDB Edwards Aquifer Model for this pumpage scenario were adjusted to account for monthly differences in simulated and actual springflows based on historical pumpage. Springflows based on pumpage of 543,677 acft/yr were compared to those for 400,000 acft/yr (previously provided

²⁶ Texas Water Development Board, "Ground-water Resources and Model Applications for the Edwards (Balcones Fault Zone) Aquifer in the San Antonio Region," Report 239, October, 1979.

by the TWDB²⁷) to estimate monthly quantities of enhanced springflow at Comal, San Marcos, and other springs originating in the Edwards Aquifer. These comparisons show increases in Comal Springs discharge of about 84,500 acft/yr over the long-term (1934-89) and of about 40,400 acft/yr during drought (1947-56).

In order to estimate the portion of this enhanced springflow potentially available for diversion from Lake Dunlap after honoring downstream water rights, it was first necessary to determine the baseline firm yield of Canyon Lake subject to Edwards Aquifer pumpage of 543,677 acft/yr. Assuming full subordination of Guadalupe River hydropower water rights to Canyon Lake and return flows at rates reported for 1989, the uncommitted firm yield of Canyon Lake diverted at Lake Dunlap would be 40,200 acft/yr after honoring Guadalupe-Blanco River Authority (GBRA) contractual commitments from Canyon Lake totaling 38,438 acft/yr. Releases, spills, and firm yield diversions from this simulation were held constant for all water availability analyses for Alternative G-33. Hence, it was assumed that any increases in springflow resulting from the reduction of Edwards Aquifer pumpage to 400,000 acft/yr would not accrue to the firm yield of Canyon Lake, but could accrue to downstream consumptive water rights. Enhanced springflow was not allowed to increase Canyon Lake storage or yield because the application of this assumption would maximize water availability for diversion under this alternative over the long-term and take advantage of storage capacity in the Edwards Aquifer through recharge enhancement. Furthermore, flows past the Saltwater Barrier from this baseline simulation were preserved when quantifying water potentially available for diversion under both enhanced springflow and existing water rights transfers.

The Guadalupe - San Antonio River Basin Model (GSA Model) was used to compute water availability below Comal Springs at Lake Dunlap for Edwards Aquifer pumpage scenarios of 543,677 acft/yr and 400,000 acft/yr subject to existing water rights and contracts and a range of maximum monthly diversion rates. Month by month comparison of water availability estimates under the two aquifer pumpage scenarios reveals the balance of enhanced springflow available for diversion assuming existing surface water rights are honored first. These comparisons indicate that water averaging up to 82,900 acft/yr over the long-term (1934-89) and 36,000 acft/yr during

²⁷ HDR Engineering, Inc., "Guadalupe - San Antonio River Basin Recharge Enhancement Study," Edwards Underground Water District, September, 1993.

drought (1947-56) could be available at Lake Dunlap from enhanced springflow. Hence, up to 89 percent (drought average) or 98 percent (long-term average) of the total enhanced springflow could be available for diversion after honoring existing surface water rights. Water availability from enhanced springflow is presented as a function of maximum diversion rate in Figure J5-3 in Appendix J.

Water Rights Transfer

Review of records of reported surface water use provided by the Texas Natural Resources Conservation Commission (TNRCC) indicates that less than 40 percent of existing diversion rights in the Guadalupe - San Antonio River Basin were utilized in calendar year 1989. Figure J5-2 in Appendix J provides comparisons of authorized diversion rights and 1989 reported use for selected stream reaches. For Alternative G-33, it was assumed that the portion of all existing rights unutilized in 1989 could be transferred by purchase or lease to supplement water potentially available for diversion at Lake Dunlap. After adjusting water rights to 1989 reported uses, accounting for diversions under enhanced springflow, and preserving unappropriated streamflow at the Saltwater Barrier, water potentially available for diversion under the transfer of existing, unutilized rights was computed using the GSA Model. Trans-Texas Environmental Criteria were not applied as these diversions would be made under existing water rights. Freshwater inflows to the Guadalupe Estuary would remain unchanged or increase due to enhanced springflow (relative to that which would have occurred under the assumed baseline Edwards Aquifer pumpage of 543,677 acft/yr) and/or reduced water rights diversions. Combined water availability from enhanced springflow and water rights transfers is presented as a function of maximum diversion rate in Figure J5-3 in Appendix J.

Unappropriated Flow

The GSA Model was used to calculate unappropriated streamflow potentially available for diversion from Lake Dunlap after accounting for diversions under enhanced springflow and water rights transfers. Unappropriated streamflow was calculated subject to Trans-Texas Environmental Criteria for Instream Flows and for Freshwater Inflows to Bays & Estuaries (Appendix C, Volume 2).

Total Water Availability

Combining water potentially available from each of these sources results in total water availability which is presented as a function of maximum diversion rate in Figure 3.45-2 and Figure J5-3 in Appendix J. Figure J5-5 in Appendix J provides a graphical summary of annual availability for each source of water prior to limitation by maximum diversion rate. Combined water availability during drought (1947-56) is comprised of 38 percent enhanced springflow, 54 percent water rights transfers, and 8 percent unappropriated streamflow. A significant portion of the water potentially available under water rights transfers could be obtained through arrangements with a limited number of the largest water rights holders rather than negotiating with all holders of presently unutilized water rights in the basin.

Optimization analyses considering a range of potential import pipeline diameters were performed to select the most appropriate importation facilities for this alternative based on minimum unit cost and reasonable incremental unit cost of Edwards Aquifer recharge enhancement. These optimization analyses (described in Section 3.45.5) resulted in the selection of an 84-inch diameter import pipeline. Water potentially available for diversion to the recharge zone via an 84-inch diameter pipeline would average 123,200 acft/yr over the long-term (1934-89) and 70,300 acft/yr during drought (1947-56). As is apparent in Figure 3.45-2, water would be available for diversion at or very near full import pipeline capacity in about two-thirds of the years simulated.

3.45.3 Environmental Issues

Alternative G-33 involves the diversion of water from Lake Dunlap on the Guadalupe River to the Edwards Aquifer recharge zone in northern Bexar County. This alternative is similar in recharge zone delivery points to Alternative G-14B described in Section 3.19 of Volume 2 and is also similar to Alternative G-27 described in Section 3.40 of Volume 3, with respect to transmission pipeline capacity and quantities of water to be diverted. Alternative G-33 would use the same pipeline route as proposed for Alternative G-14B, however, Alternative G-33 would not likely require an off-channel reservoir near Lake Dunlap.

Lake Dunlap is a long, moderately deep reservoir within the banks of the Guadalupe River. It is formed by a small hydroelectric dam downstream of the Guadalupe River confluence

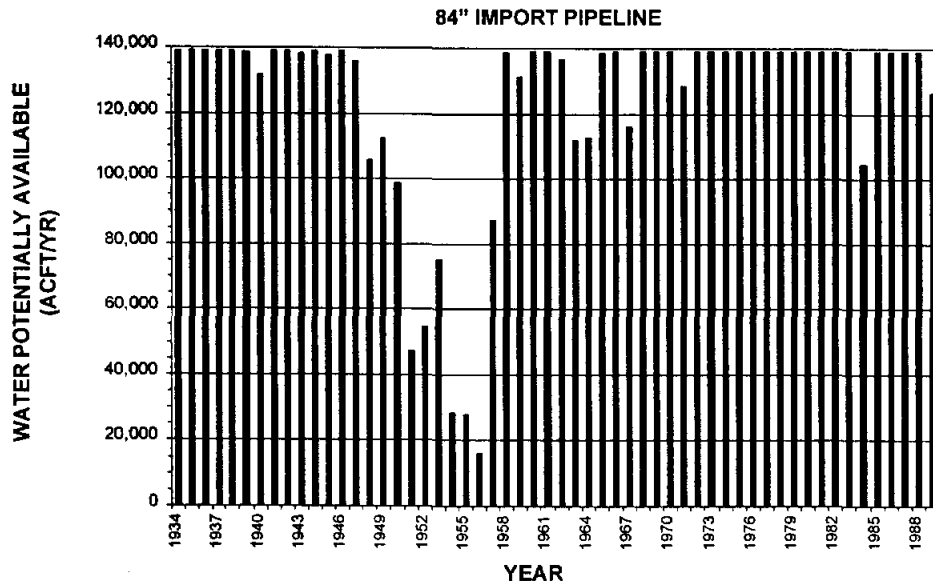
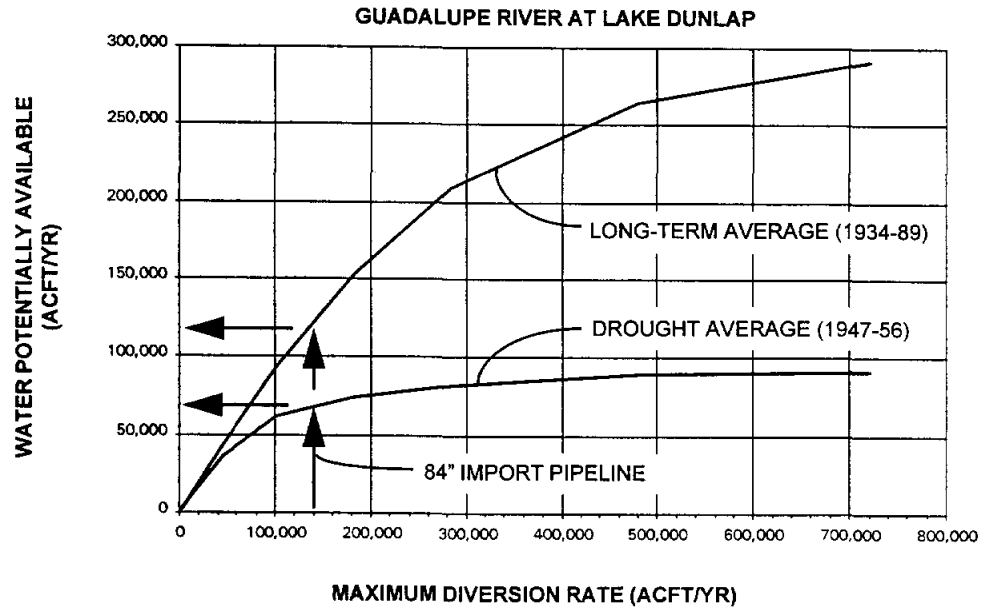

ASSUMPTIONS:

1. DIVERSIONS UNDER ENHANCED SPRINGFLOW, WATER RIGHTS UNUTILIZED IN 1989, AND UNAPPROPRIATED STREAMFLOW FROM LAKE DUNLAP FOR IMPORT TO THE EDWARDS AQUIFER RECHARGE ZONE IN NORTHERN BEXAR COUNTY.
2. ENHANCED SPRINGFLOWS RESULTING FROM SIMULATED REDUCTION OF FIXED EDWARDS AQUIFER PUMPAGE FROM 543,677 ACFT/YR (1989) TO 400,000 ACFT/YR.
3. HYDROPOWER WATER RIGHTS FULLY SUBORDINATED TO CANYON LAKE.
4. UNCOMMITTED FIRM YIELD OF CANYON LAKE DIVERTED NEAR NEW BRAUNFELS.
5. RETURN FLOWS SET AT RATES OBSERVED IN 1989.

**TRANS TEXAS WATER PROGRAM /
WEST CENTRAL STUDY AREA**



**WATER AVAILABILITY
SUMMARY
ALTERNATIVE G-33**

with the Comal River. In addition to hydroelectric power generation, Lake Dunlap is used for boating and fishing.

Habitat types present and land uses in the project area reflect its location at the boundaries of the Edwards Plateau, Blackland Prairies, and Post Oak Savannah Vegetational Areas.²⁸ The Edwards Plateau is a deeply dissected, rapidly drained rocky plain with broad, flat to undulating divides. The original vegetation was grassland or open savannah-type plains with tree or brushy species found along rocky slopes and stream bottoms. In Bexar County, the Balcones Escarpment forms a distinct border of the plateau on its southeastern boundary with the Blackland Prairies. Streams flowing from the Edwards Plateau have cut spectacular canyons through the Balcones Escarpment. Because of the many large canyons and rugged terrain, this area is botanically of much interest and has consequently been visited by many botanical collectors. The ferns as well as many of the flowering plants are primarily lithophilous, and are represented mainly by various species of lipferns, (*Cheilanthes spp.*), cloak-ferns (*Notholaena spp.*) and cliff brakes (*Pellaea spp.*). Columbine (*Aquilegia canadensis*), endemics such as *Anemone edwardsensis* and wand butterfly-bush (*Buddleja racemosa*) and other species are sometimes found together on large boulders in shaded ravines along with such species as mock-orange (*Philadelphus spp.*), American smoke-tree (*Cotinus americana*), spicebush (*Benzoin aestivale*) and the endemic silver bells (*Styrax platanifolia* and *S. texana*).

The most important climax grasses of the Plateau include switchgrass, several species of bluestems and grammas, Indian grass (*Sorghastrum nutans*), Canada wild-rye (*Elymus canadensis*), curly mesquite (*Hilaria berlandieri*) and buffalograss (*Buchloe dactyloides*). The rough, rocky areas typically support a tall or mid-grass understory and a brush overstory complex consisting primarily of live oak (*Quercus virginiana*), Texas oak (*Q. buckleyi*), shinnery oak (*Q. havardii*), juniper species (*Juniperus*) and mesquite (*Prosopis glandulosa*). Throughout the region, the brush species are generally considered as "invaders" with the climax stages composed of grassland or open savannah. The steeper canyon slopes historically supported a dense cedar-oak thicket.

The Blackland Prairies and Post Oak Savannah Vegetational Regions intermingle in the Bexar and Guadalupe County areas and have divisions known as the San Antonio and Fayette

²⁸ Gould, F.W. 1962. Texas Plants--A checklist and ecological summary. Texas Agricultural Experiment Station. MP-585.

Prairies. These well-dissected, rolling prairies represent the southern extension of the true prairie which extends from Texas to Canada. Soils in the project area range between light-colored, acid sandy loams in the upland areas, dark-gray acid sandy loams and clays (bottomland), and fairly uniform dark-colored calcareous clays.

Blackland Prairie is considered a true prairie with little bluestem (*Schizachyrium scoparium* var. *frequens*) as a climax dominant. Other important grasses include big bluestem (*Andropogon gerardii* var. *gerardii*), Indian grass, switchgrass, sideoats grama (*Bouteloua curtipendula*), hairy grama, (*Bouteloua hirsuta*), tall dropseed (*Sporobolus asper*), silver bluestem and Texas wintergrass (*Stipa leucotricha*). Under heavy grazing, Texas wintergrass, buffalograss (*Buchloe dactyloides*), Texas grama (*Bouteloua rigidisetata*), smutgrass (*S. indicus*) and many annuals increase or invade these areas. Mesquite also has invaded hardland sites of the southern portion of the Blackland Prairies. Post oak (*Q. stellata*) and blackjack oak (*Q. marilandica*) increase on the medium- to light-textured soils. Although classed as a true prairie, the Blackland Prairie has substantial amounts of timber, especially along the streams that traverse it. Common tree species include a variety of oaks, pecan (*Carya illinoensis*), cedar elm (*Ulmus crassifolia*), bois d'arc (*Maclura pomifera*), and mesquite. Some authorities consider the plant association as part of the oak-hickory formation. Based on the fact that the typical understory vegetation is tall grass, others classify the area as part of the true prairie association of the grassland formation. There is evidence that the brush and tree densities have increased tremendously from the virgin condition.

Topography of the Post Oak Savannah is gently rolling to hilly. Rainfall averages 35 to 45 inches annually. Soils on the uplands are light-colored, acid sandy loams or sands. Bottomland soils are light-brown to dark-gray and acid, ranging in texture from sandy loams to clays. Although most of the Post Oak Savannah is in native or improved pastures, small farms are common. Climax grasses include little bluestem, Indian grass, switchgrass (*Panicum virgatum*), purpletop (*Tridens flavus*), silver bluestem (*Bothriochloa saccharoides*), Texas wintergrass (*Stipa leucotricha*) and narrowleaf woodoats (*Chasmanthium sessiliflorum*). The overstory is primarily post oak and blackjack oak. Many other brush and weedy species are also common. Some invading plants are red lovegrass (*Eragrostis oxylepis*), broomsedge (*Andropogon virginicus*), splitbeard bluestem (*Andropogon ternarius*), yankeeweed (*Eupatorium compositifolium*),

bullnettle (*Cnidocolus texanus*), greenbrier (*Smilax sp.*), yaupon (*Ilex vomitoria*), smutgrass (*Sporobolus indicus*) and western ragweed (*Ambrosia trifida*).

A construction ROW 140 feet in width would be required for installation of 18.7 miles of import pipeline extending from Lake Dunlap to a point near the intersection of FM 1604 and FM 1357 (potential location of North Water Treatment Plant). A total of 317.3 acres would be affected including 30.8 acres (9.7 percent) of wood, 7.9 acres (2.5 percent) of park, 8.2 acres (2.6 percent) of brush, and 270.4 acres (85.2 percent) of crop/pasture. A 40 foot wide ROW affecting about 90.7 acres would be maintained free of woody vegetation for the life of the project. About 4.7 acres of riparian woodland would be affected along several intermittent streams including Long, Santa Clara, and Cibolo Creeks and on the shoreline of Lake Dunlap. As the alignment of the remainder of the import pipeline extending into northern Bexar County and the exact locations and sizes of recharge dams are not known at this time, specific estimates of associated acreage affected were not computed.

Although the Natural Heritage Program's database did not report any endangered or threatened species along the proposed pipeline corridor, some have been reported in the vicinity.²⁹ The grasslands, brush, and shrub could provide habitat for endangered or threatened species such as the Texas horned lizard (*Phrynosoma cornutum*) and Texas garter snake (*Thamnophis sirtalis annectens*). Patches of preferred habitat for the golden-cheeked warbler (*Dendroica chrysoparia*) and black-capped vireo (*Vireo atricapillus*), are likely to occur in the area, however, these could be easily avoided by careful routing of the pipeline. Both species of these birds are listed as endangered by U.S. Fish and Wildlife Service and Texas Parks and Wildlife Department. Other important species possibly occurring in Bexar and Guadalupe Counties are listed in Tables 6 and 22 of Appendix B, Volume 2.

Potential changes in streamflow resulting from the implementation of Alternative G-33 were evaluated for the Guadalupe River below Lake Dunlap and below the Saltwater Barrier. Monthly median streamflows and annual streamflows averaged by decile at each of these locations with and without the project are presented in Figure 3.45-3. In order to be consistent with the

²⁹ TPWD. 1994. Unpublished data files and maps of the Natural Heritage Program. Resource Protection Division, Austin, Texas. TOES. 1992. Endangered, Threatened, and Watch List of Natural Communities of Texas, Publication 8, Austin, Texas; TOES 1993. Endangered, Threatened, and Watch List of Texas Plants, Third Revision, Austin, TX.

3.46 Cibolo Reservoir with Imported Water from the San Antonio, Guadalupe, and Colorado Rivers (S-15D)

3.46.1 Description of Alternative

Cibolo Reservoir is a proposed impoundment on Cibolo Creek in Wilson County located about 8 miles east of Floresville. The project has been studied by the U.S. Bureau of Reclamation (USBR)^{37,38}, and more recently, by Espey, Huston, and Associates, Inc. (EHA) which studied two potential dam sites in 1986³⁹. The more downstream of the two sites, which would provide the greater storage capacity, has been selected for consideration in the Trans-Texas Water Program. An evaluation of Cibolo Reservoir using only runoff from the Cibolo Creek watershed was presented in Section 3.15 of Volume 2 of this Phase I Interim Report.

Cibolo Reservoir has a proposed conservation capacity of about 409,700 acft below elevation 416 ft-MSL. As noted in Section 3.15 of Volume 2 (see Figure 3.15-2), the reservoir would fill only infrequently with runoff from the Cibolo Creek watershed leaving ample capacity available for storage of water from other sources. Hence, Alternative S-15D as presented herein includes importation of unappropriated water from the San Antonio, Guadalupe, and Colorado Rivers to Cibolo Reservoir through a system of river intakes, pump stations, and pipelines as shown in Figure 3.46-1. The enhanced firm yield of Cibolo Reservoir would then be delivered to the proposed South Water Treatment Plant for distribution to municipal water systems in the San Antonio area. Three independent importation source scenarios for Cibolo Reservoir have been studied and are described as follows:

- S-15Da** Importing water from the San Antonio River near Floresville;
- S-15Db** Importing water from the San Antonio River near Floresville and the Guadalupe River at Cuero; and
- S-15Dc** Importing water from the San Antonio River near Floresville, the Guadalupe River at Cuero, and the Colorado River near Columbus.

³⁷ U.S. Bureau of Reclamation (USBR), "Feasibility Report, Cibolo Project, Texas," February, 1971.

³⁸ USBR, "Texas Basins Project," February, 1965.

³⁹ Espey, Huston, and Associates, Inc., "Water Availability Study for the Guadalupe and San Antonio River Basins," February, 1986.

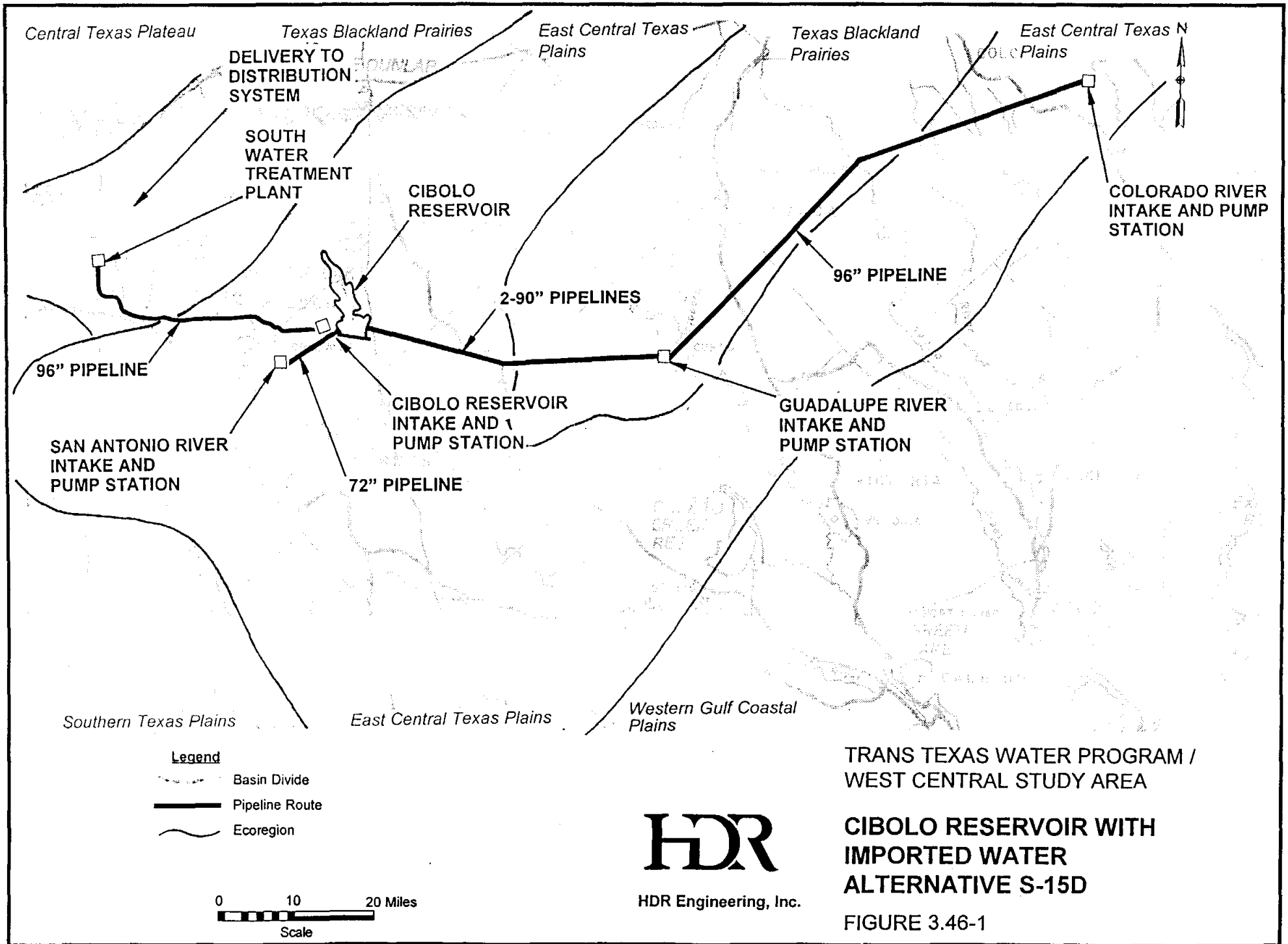

3.46.2 Available Yield

Water potentially available for impoundment in the proposed Cibolo Reservoir and for importation from the San Antonio and Guadalupe Rivers was estimated using the Guadalupe-San Antonio River Basin Model⁴⁰ (GSA Model) using a 1934-89 period of record. The GSA Model estimates monthly quantities of total streamflow and unappropriated streamflow available at the reservoir site and points of diversion for importation. For modeling purposes, water availability in the Guadalupe - San Antonio River Basin was estimated at the following locations:

- Cibolo Creek near Falls City (ID #1860);
- San Antonio River below Calaveras Creek and above Floresville; and
- Guadalupe River at Cuero (ID #1758).

All estimates of water potentially available for diversion from the Guadalupe - San Antonio River Basin to the proposed Cibolo Reservoir include springflows resulting from a fixed Edwards Aquifer pumpage rate of 400,000 acft/yr with existing recharge structures, full utilization of existing water rights, and hydropower water rights fully subordinated to Canyon Lake.

Water potentially available for diversion from the San Antonio River near Floresville and the Guadalupe River at Cuero was estimated subject to both original (Appendix C, Volume 2) and alternative⁴¹ Trans-Texas Environmental Criteria for Instream Flows and Freshwater Inflows to Bays and Estuaries. The alternative criteria uses the 35th percentile, 4-month moving average streamflow as a triggering mechanism for the implementation of drought contingency provisions lowering the minimum desired streamflow for a given month to the 10th percentile streamflow (10-year low flow).

The water availability analyses proceeded in a sequential manner, starting at the San Antonio River above Floresville, moving next to the Guadalupe River at Cuero, and, finally, adding unappropriated water potentially available from the Colorado River near Columbus. Water potentially available for diversion from the San Antonio River above Floresville was computed assuming reuse of available San Antonio Water System (SAWS) treated effluent. The GSA Model was used to estimate monthly SAWS effluent quantities arriving at the proposed diversion

⁴⁰ HDR Engineering, Inc., "Guadalupe- San Antonio River Basin Recharge Enhancement Study," Volumes I, II, and III, Edwards Underground Water District, September, 1993.

⁴¹ HDR Engineering, Inc., "Evaluation of Alternative Instream and Bay & Estuary Flow Criteria for Run-of-the-River Diversions," Technical Memorandum, Trans-Texas Water Program, West Central Study Area, June, 1995.

point near Floresville after consideration of other uses for reclaimed water including the Tunnel Reuse Project and make-up water for Braunig and Calaveras Lakes. Assuming diversion of available SAWS effluent, unappropriated streamflows above Floresville were then estimated subject to environmental criteria using the GSA Model. The monthly sum of unappropriated streamflow and SAWS effluent determined total availability from the San Antonio River above Floresville. Daily gaged flows for the San Antonio River near Falls City (ID#1835) for the 1934-89 period were analyzed in order to determine a typical percentage of water available on a monthly basis which could be diverted on a daily basis subject to reuse of SAWS treated effluent, downstream water rights, selected diversion rates, and daily streamflow variations. This analysis indicated that, on average, about 85 percent of the monthly volume of the streamflow available for diversion from the San Antonio River could be diverted to Cibolo Reservoir considering the daily distribution of flows. Maximum monthly diversions to Cibolo Reservoir were, therefore, limited to 85 percent of the estimated water available in the San Antonio River.

Once total water available from the San Antonio River above Floresville was established, unappropriated streamflow from the Guadalupe River at Cuero was estimated. Water availability estimates for the Guadalupe River at Cuero accounted for water diverted from the San Antonio River, avoiding overestimation of unappropriated water in the Guadalupe River. Based on analysis of daily gaged streamflows for the Guadalupe River at Cuero for the 1964-89 historical period (see Section 3.22, Volume 2), maximum monthly diversions to Cibolo Reservoir were limited to 80 percent of the estimated water available in the Guadalupe River.

Unappropriated streamflow potentially available from the Colorado River near Columbus was estimated on a daily timestep using the Colorado River Daily Allocation Program (DAP). This computer model was developed by the Lower Colorado River Authority (LCRA) and applied by LCRA staff to estimate unappropriated water potentially available for diversion. The model simulates flows in the Colorado River and allocates these flows to diverters, based on seniority of water rights, for a 1941-65 period of record. Water availability estimates from the Colorado River presented in this study were not subjected to Trans-Texas Environmental Criteria and may overstate quantities of unappropriated streamflow.

The GSA Model was used to estimate monthly quantities of total streamflow and unappropriated streamflow potentially available at Cibolo Reservoir. For modeling purposes,

streamflows for Cibolo Creek near Falls City (ID#1860) were assumed to be representative of inflows to the reservoir. The firm yield of the proposed Cibolo Reservoir with and without imported water was computed using an original model (RESSIM) specifically written to simulate reservoir operations subject to Trans-Texas Environmental Criteria for New Reservoirs. The firm yield of Cibolo Reservoir based solely on runoff from the Cibolo Creek watershed (see Section 3.15, Volume 2) is estimated to be about 32,300 acft/yr for a drought trigger at 60 percent of storage capacity. This yield estimate serves as the baseline to which enhanced yield estimates for the three importation source scenarios previously listed are compared.

Optimization analyses considering a range of potential import pipeline diameters were performed to select the most appropriate importation facilities for each scenario based on minimum unit cost and reasonable incremental unit cost of additional Cibolo Reservoir firm yield. These optimization analyses are presented in greater detail in Section 3.46.5. Total system firm yield estimates for Cibolo Reservoir with selected importation facilities under each scenario are summarized in Table 3.46-1.

3.46.3 Environmental Issues

The proposed Cibolo Reservoir near Stockdale (Alternative S-15) has been described previously (Section 3.15, Volume 2), hence, the following discussion focuses on issues relevant to diverting water from the San Antonio, Guadalupe, and Colorado Rivers, and the transmission pipelines required to transport it to the proposed Cibolo Reservoir (Figure 3.46-1). Alternative S-15D involves water transmission lines between the San Antonio River near the City of Floresville and the proposed Cibolo Reservoir, and between the Colorado River east of the City of Altair (upstream from Garwood) and Cibolo Reservoir. Additional water would be diverted from the Guadalupe River where the Colorado River to Cibolo Reservoir pipeline crosses the Guadalupe River near the City of Cuero.

The project area for Alternative S-15D includes Colorado, Lavaca, Dewitt, Karnes, and Wilson Counties. The proposed Floresville to Cibolo Reservoir pipeline lies within the South Texas Plains Vegetational Area near its northern boundary with the Blackland Prairies Vegetational Area. The Colorado River to Cibolo Reservoir pipeline courses through the Post Oak Savannah Vegetational Region in Colorado County, near the boundary between the

Table 3.46-1		
Summary of Firm Yield Estimates for Cibolo Reservoir with Imported Water from the San Antonio, Guadalupe, and Colorado Rivers (S-15D)		
Sources of Imported Water to Cibolo Reservoir	Total Firm Yield (acft/yr) ¹	
	Original Trans-Texas Environmental Criteria ²	Alternative Environmental Criteria ³
Baseline: Cibolo Reservoir yield without Imported Water	32,300	-
San Antonio River near Floresville (S-15Da)	75,600 ⁴	80,600 ⁵
San Antonio River near Floresville and Guadalupe River at Cuero (S-15Db)	79,600 ⁶	106,100 ⁷
San Antonio River near Floresville, Guadalupe River at Cuero, and Colorado River near Columbus (S-15Dc) ⁹	162,900 ⁸	-

¹ Total firm yield of Cibolo Reservoir with selected pipeline(s) from import optimization analyses.
² Appendix C, Volume 2.
³ Applies only to run-of-the-river diversion of water for importation to Cibolo Reservoir. Baseline firm yield of Cibolo Reservoir based on Original Trans-Texas Environmental Criteria for New Reservoirs.
⁴ Importing water via 72-inch pipeline from San Antonio River near Floresville.
⁵ Importing water via 84-inch pipeline from San Antonio River near Floresville.
⁶ Importing water via 72-inch pipeline from San Antonio River near Floresville and 84-inch pipeline from the Guadalupe River at Cuero.
⁷ Importing water via 84-inch pipeline from San Antonio River near Floresville and 108-inch pipeline from the Guadalupe River at Cuero.
⁸ Importing water via 72-inch pipeline from San Antonio River near Floresville, two (2) 90-inch pipelines from Guadalupe River at Cuero, and 96-inch pipeline from the Colorado River near Columbus.
⁹ Colorado River near Columbus unappropriated water availability presented in this analysis not subject to run-of-the-river environmental criteria.

Blackland Prairies and Post Oak Savannah in Lavaca and northern Dewitt Counties, and through the South Texas Plains in southern Dewitt, Karnes and Wilson Counties.

The South Texas Plains lie within Blair's Tamaulipan Biotic Province. The Post Oak Savannah and Blackland Prairies Vegetational Regions lie within the Texan Biotic Province. The Texan Biotic Province is an ecotone, or ecologically transitional region between the Austroriparian Biotic Province to the northeast and the Tamaulipan Province to the southwest. The plant and animal species of the Texan Province are a mixture of species characteristic of the Austroriparian and Tamaulipan Provinces. Furthermore, riparian woodlands dissecting the Texan

Province provide corridors for migration and an important habitat type in this predominately grassland region.

The Blackland Prairies region includes the San Antonio and Fayette Prairies. Topography is gently rolling to nearly level, well-dissected with rapid surface drainage. Blackland Soils are fairly uniform dark-colored calcareous clays interspersed with some gray acid sandy loams. For the most part, this fertile area has been brought under cultivation, although a few native hay meadows and ranches remain. The Blackland Prairies Vegetational Region is a true prairie with little bluestem (*Schizachyrium scoparium* var. *frequens*) as a climax dominant. Other important grasses include big bluestem, Indian grass, switchgrass (*Panicum virgatum*), sideoats grama (*Bouteloua curtipendula*), hairy grama, (*Bouteloua hirsuta*), tall dropseed (*Sporobolus asper*), silver bluestem (*Bothriochloa saccharoides*) and Texas winter-grass (*Stipa hirsuta*). Under heavy grazing, Texas wintergrass, buffalo grass (*Buchloe dactyloides*), Texas grama (*B. rigidiseta*), smutgrass and many annuals increase or invade. Mesquite (*Prosopis glandulosa*) also has invaded hardland sites of the southern portion of the Blackland Prairies. Post oak (*Quercus stellata*) and blackjack oak (*Q. marilandica*) increase on the medium- to light-textured soils. Although classed as a true prairie, the Blackland Prairie has much timber, especially along the streams that traverse it. Common tree species include a variety of oaks, pecan, cedar elm (*Ulmus crassifolia*), bois d'arc (*Maclura pomifera*) and mesquite.

The Post Oak Savannah Area lies immediately west of the primary forest region of Texas.⁴² Some authorities consider the plant association as part of the oak-hickory formation. Based on the fact that the typical understory vegetation is tall grass, others classify the area as part of the true prairie association of the grassland formation. There is evidence that the brush and tree densities have increased tremendously from the virgin condition. Topography of the Post Oak Savannah is gently rolling to hilly. Rainfall averages 35 to 45 inches annually. Soils on the uplands are light-colored, acid sandy loams or sands. Bottomland soils are light-brown to dark-gray and acid, ranging in texture from sandy loams to clays. Most of the Post Oak Savannah is in native or improved pastures although small farms are common. Climax grasses include little bluestem, Indian grass, switchgrass, purpletop (*Tridens flavus*), silver bluestem, Texas

⁴² Correl, D.S. and M.C. Johnston. 1979. Manual of the Vascular Plants of Texas. The Univ. Texas at Dallas, Richardson, Texas.

wintergrass (*Stipa leucotricha*) and *Chasmanthium sessiliflorum*. The overstory is primarily post oak and blackjack oak. Many other brush and weedy species are also common. Some invading plants are red lovegrass, broomsedge, splitbeard bluestem (*Andropogon ternarius*), yankeeweed, bullnettle (*Cnidocolus texanus*), greenbrier, yaupon (*Ilex vomitoria*), smutgrass and western ragweed.

The South Texas Plains are also termed the Rio Grande Plains, or Tamaulipan Brushlands.⁴³ The South Texas Plains Vegetational Area and the Gulf Prairies and Marshes Vegetational Area correspond with the Southern Texas Plains Ecoregion⁴⁴ and the Western Gulf Coastal Plain Ecoregion⁴⁵ respectively. The topography is level to rolling, and the land is dissected by arroyos or by streams flowing into the Rio Grande and Gulf of Mexico. It is characterized by open prairies and a growth of mesquite, grangeno (*Celtis pallida*), cacti, clepe (*Ziziphus obtusifolia*), coyotillo (*Karwinskia Humboldtiana*), guayacan (*Porlieria angustifolia*), white brush (*Aloysia gratissima*), brasil (*Condalia Hookeri*), bisbirinda (*Castela texana*), cenizo (*Leucophyllum spp.*), huisache (*Acacia Farnesiana*), catclaw (*A. greggii*), black brush (*A. rigidula*), guajillo (*A. Berlandieri*) and other small trees and shrubs which are found in varying degrees of abundance and composition.⁴⁶ Although historically the area was grassland or savannah type climax vegetation, long-continued heavy grazing and other factors have resulted in a general change to a cover of shrubs and low trees. Among the several species of shrubs and trees that have made dramatic increases are mesquite, live oak, post oak, *Opuntia spp.* and *Acacia spp.*⁴⁷ Blair⁴⁸ described the South Texas Plains (Tamaulipan Province) as being characterized by the predominance of thorny brush vegetation. This brushland stretches from the Balcones fault line southward into Mexico. A few species of plants account for the bulk of the brush vegetation and give it a characteristic aspect throughout the Tamaulipan Biotic Province of Texas. The most important include: mesquite, lignum vitae (*Porlieria angustifolia*), cenizo (*L. texanum*), white brush (*A. gratissima*), prickly pear (*O. lindheimeri*), *tasajillo* (*O. leptocaulis*), *Condalia sp.* and

⁴³ Correll, D. S. and M. C. Johnston. 1979. Manual of the Vascular Plants of Texas. The University of Texas at Dallas.

⁴⁴ Omernik, James M. 1986. Ecoregions of the Conterminous United States. Annals of the Association of American Geographers, 77(1):pp. 118-125.

⁴⁵ Ibid.

⁴⁶ Correll, D. S. and M. C. Johnston. 1979. Op. Cit.

⁴⁷ Gould, F. W. 1975. The grasses of Texas. Texas A&M University Press.

⁴⁸ Blair, F.W. 1950. The biotic provinces of Texas. The Texas Journal of Science. 2:93-117.

Castela sp. The brush on sandy soils differs in species and aspect from that on clay soils. Mesquite, in an open stand and mixed with various grasses, is characteristic of sandy areas. Clay soils usually have all of the species listed above, including mesquite. Although rangeland predominates throughout the South Texas Plains/Tamaulipan Brushland, land use also includes significant acreages in croplands.

The water transmission pipeline between the San Antonio River and Cibolo Reservoir (Figure 3.46-1) would be about 9.5 miles long. A construction ROW 140 feet wide would affect about 161 acres including 16 acres (10.4%) of grassland/pasture, 51 acres (31.6%) of brush, 7 acres (4.1%) of park, and 87 acres (53.9%) of crop. A 40-foot wide ROW maintained free of woody vegetation for the life of the project would total 46 acres with those areas in grassland/pasture or cropland expected to return to their original condition. Texas Natural Heritage program records indicate that Park's jointweed (*Polygonella parksii*) and Elmendorph's onion (*Allium elmendorii*) could occur along the proposed route. Site records for Park's jointweed and Elmendorph's onion are reported near the City of Floresville (Floresville and Dewees USGS 7.5 minute quadrangle). Park's jointweed is in the Knotweed family and has been assigned a status of 3C (no longer under federal review for listing; either more abundant or widespread than was previously thought) by U.S. Fish and Wildlife Department. However, Park's jointweed has been assigned a state rank of 2C (imperiled in the state because of rarity; very vulnerable to extirpation) by Texas Parks and Wildlife Department.

The water transmission pipeline between the Colorado River east of the City of Altair and Cibolo Reservoir would be about 108 miles long. A construction ROW 140 feet wide would affect a total of 1840 acres including 370 acres (20.1%) of grassland/pasture, 695 acres (37.8%) of brush, 31 acres (1.7%) of park, 35 acres (1.9%) of wood, and 641 acres (34.8%) of crop. About 68 acres (3.7%) has been developed for residential, commercial, and industrial purposes. A 40 foot wide ROW maintained free of woody vegetation for the life of the project would total 526 acres. Those areas within the 40 foot maintenance ROW that lie within grassland/pasture and cropland would be expected to return to their original condition upon completion of the project. Within 10 years, woody vegetation in the brush habitats would be expected to significantly encroach into those areas of the construction ROW which would not be mowed.

Several occurrences of the two-flower stickpea (*Polygonella biflora*) are reported by the Texas Natural Heritage Program on the Yorkton East, USGS 7.5 minute quadrangle map. One reported site occurrence is along State Highway 119 which is on the proposed pipeline route. The Texas Office of Endangered Species considers the two-flower stickpea as a "Category V. TOES Watch List" plant (has either low population or restricted range in Texas and is not declining or being restricted in its range but requires attention to insure that the species does not become endangered or threatened."

Several species potentially affected by the project are associated with the rivers. The blue sucker and Guadalupe Bass (*Micropterus treculi*), may have habitat near the proposed diversions on the Colorado and Guadalupe Rivers. The blue sucker (*Cypleptus elongatus*) is listed by U.S. Fish and Wildlife Service as a candidate (C2) for protection and by Texas Parks and Wildlife Department as Threatened. Recent studies have not reported blue sucker in the lower Guadalupe River.⁴⁹ Additionally, there is a site record for Cagle's map turtle (*Graptemys cagleii*) on the Guadalupe River south of the City of Cuero (Cuero USGS 7.5 minute quadrangle). Although Cagle's map turtle is not presently listed by U.S. Fish and Wildlife Service or Texas Parks and Wildlife Department as threatened or endangered it is listed as a federal Candidate, Category 1 (C1) species and a state S3 species (rare or uncommon).

The site of the proposed intake on the Colorado River is located in Colorado County, in the Eagle Lake Reach. A recent study conducted by the Lower Colorado River Authority (LCRA)⁵⁰ reports fish species and fish-habitat associations identified in the Colorado River downstream from Austin. There are two major diversions for rice irrigation in Eagle Lake Reach, LCRA's Lakeside Irrigation District and Garwood Irrigation Company in the reach. The Eagle Lake Reach is primarily a gravel bed stream with localized outcrops of resistant calcite cemented sands. A major clay/sandstone outcrop of the Lissie and Beaumont Formations forms the hydraulic control for Lakeside Irrigation District's diversion point. This formation constitutes the most extensive complex of rapids between the City of Columbus and the Gulf of Mexico. The

⁴⁹ Academy of Natural Sciences. 1991. A Review of Chemical and Biological Studies on the Guadalupe River, Texas, 1949-1989. Report No. 91-9. Acad. Nat. Sci. Phil. Philadelphia, PA.

⁵⁰ Mosier D.T. and R.T. Ray. 1992. Instream Flows for the Lower Colorado River: Reconciling Traditional Beneficial Uses With the Ecological Requirements of the Native Aquatic Community. Lower Colorado River Authority. Austin, TX.

LCRA⁵¹ report states that "Downstream of Columbus, the potential impact of diversions on the instream flows becomes substantial." The rock outcrops appear to provide significant spawning habitat for the blue sucker. In February 1990, numerous tuberculate males in spawning condition were observed in the rapids and gravid females were collected in pools immediately downstream. It was concluded that "target flow to maintain community diversity at Eagle Lake was 400 cfs" and that "500 cfs should be maintained from early March through May for successful spawning of *C. elongatus*."⁵² Although the American eel (*Anguilla rostrata*) is not threatened or endangered it appears it was uncommon in the fish collections and tended to be restricted in distribution to the breeding habitat of pre-spawning male blue suckers. Guadalupe Bass also was collected in the Eagle Lake reach and in various habitats. Whereas blue sucker occurred in association with particular types of habitat, there was no statistically detectable association between Guadalupe Bass and particular habitat types.⁵³

Potential changes in streamflow resulting from the implementation of the largest scale importation source scenario (S-15Dc) associated with the proposed Cibolo Reservoir were evaluated for each point of diversion in the Guadalupe - San Antonio River Basin, Cibolo Creek below Cibolo Reservoir, and the Saltwater Barrier. Monthly median streamflows and annual streamflows averaged by decile at each of these locations with and without the project are compared in Figures 3.46-2 and 3.46-3.

Modeling the operations of Cibolo Reservoir, including the interbasin transfers, indicated reduced median annual flow in Cibolo Creek from 50,743 acft/yr to 33,801 acft/yr, a decrease of 33.4 percent. Generally, estimated decreases in monthly medians ranged from 20-30 percent in months of highest flow to less than 10 percent in months typically exhibiting lowest flows. Estimated monthly medians without the project ranged between 3,806 acft/mo and 1,349 acft/mo, whereas those with the project ranged between 3,155 acft/mo and 1,349 acft/mo. The greatest reductions in flow in Cibolo Creek near Falls City would occur in the highest flow deciles. Implementation of Alternative S-15D would result in a significant reduction in terms of median annual flow and a reduction of variability in flow, especially in terms of reduced high flow events.

⁵¹ Ibid.

⁵² Ibid.

⁵³ Ibid.

SAN ANTONIO RIVER NEAR FLORESVILLE

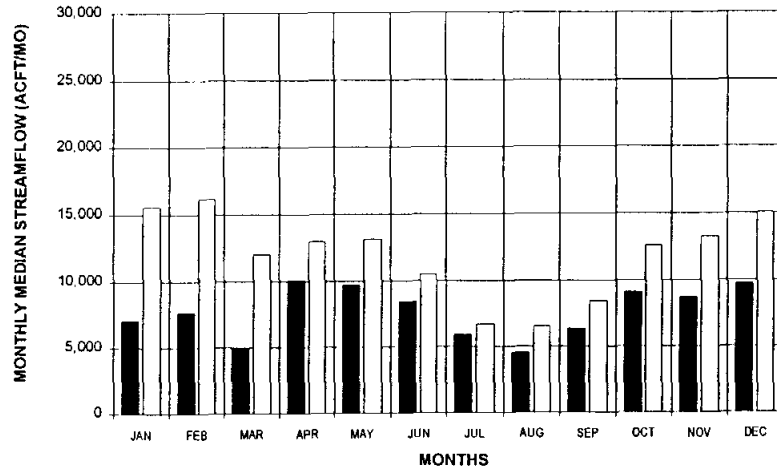

SAN ANTONIO RIVER NEAR FLORESVILLE

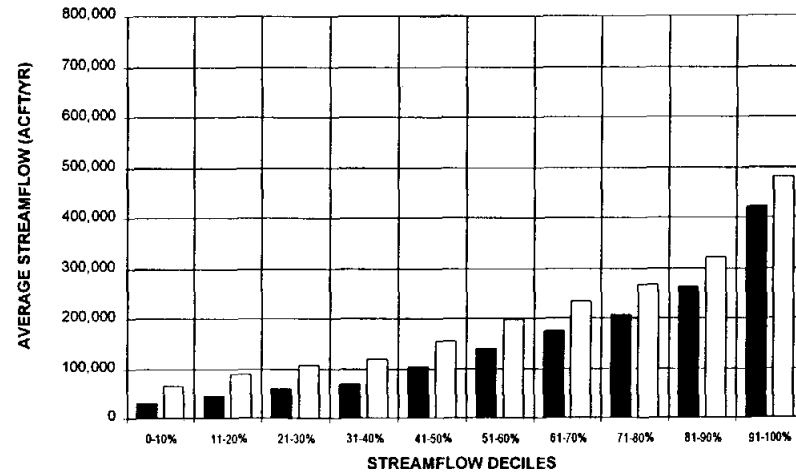

GUADALUPE RIVER AT CUERO

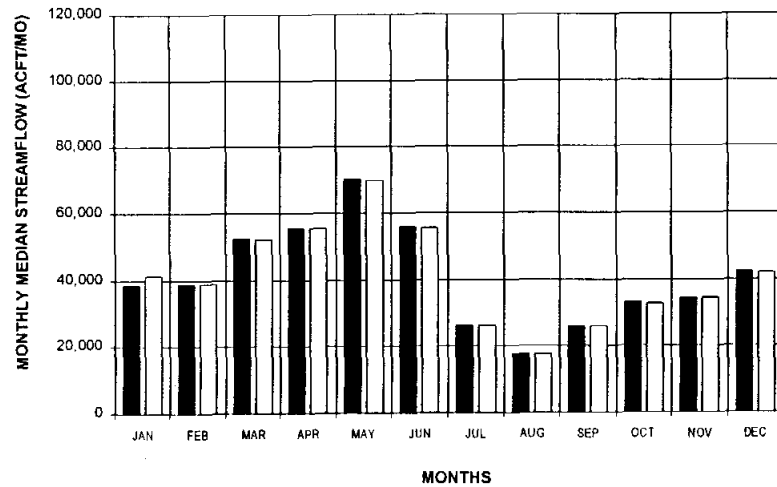

GUADALUPE RIVER AT CUERO

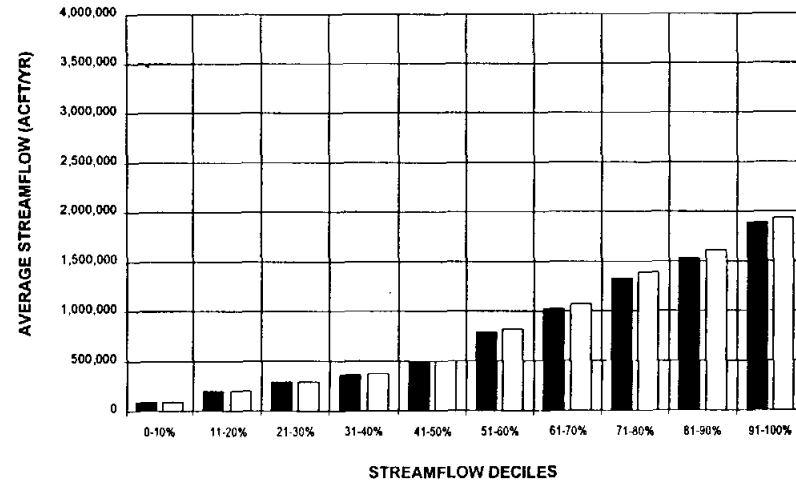

LEGEND:

- WITH PROJECT
- WITHOUT PROJECT

NOTE: STATISTICS BASED ON 1941-65 HISTORICAL PERIOD



HDR Engineering, Inc.

TRANS TEXAS WATER PROGRAM /
WEST CENTRAL STUDY AREA

CHANGES IN STREAMFLOW
SAN ANTONIO AND GUADALUPE
RIVERS, ALTERNATIVE S-15D

FIGURE 3.46-2

CIBOLO CREEK BELOW CIBOLO RESERVOIR

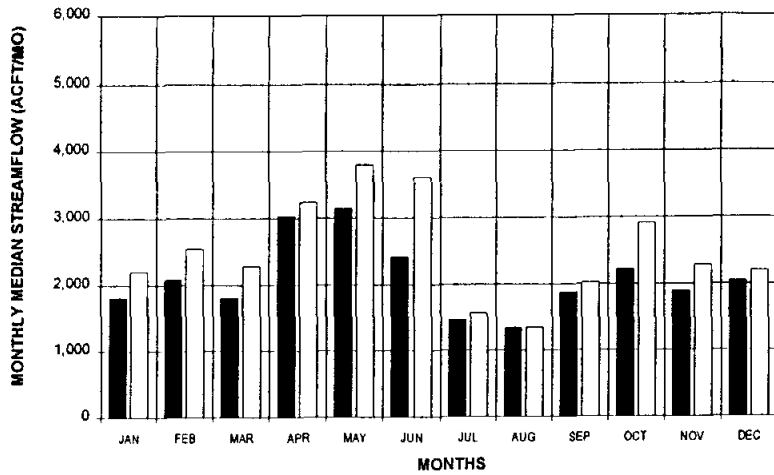

CIBOLO CREEK BELOW CIBOLO RESERVOIR

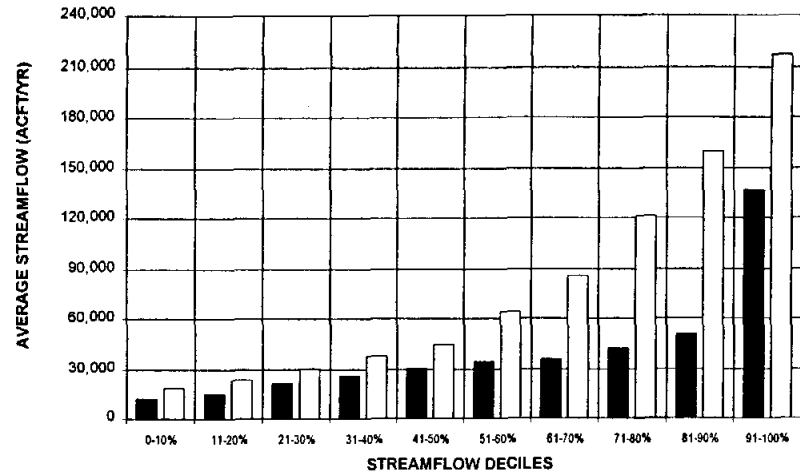

GUADALUPE RIVER BELOW SALT WATER BARRIER

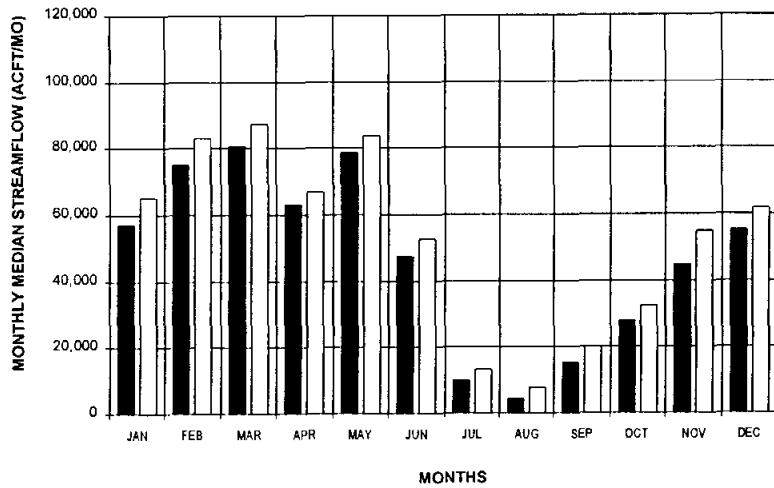

GUADALUPE RIVER BELOW SALT WATER BARRIER

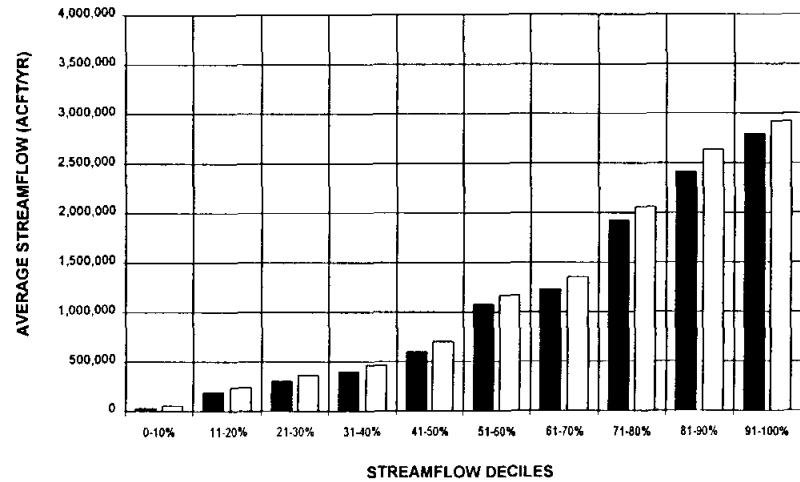

LEGEND:

- WITH PROJECT
- WITHOUT PROJECT

NOTE: STATISTICS BASED ON 1941-65 HISTORICAL PERIOD



HDR Engineering, Inc.

TRANS TEXAS WATER PROGRAM /
WEST CENTRAL STUDY AREA

CHANGES IN STREAMFLOW
CIBOLO CREEK AND SALTWATER
BARRIER, ALTERNATIVE S-15D

FIGURE 3.46-3

Results of modeling the diversion of water from the Guadalupe River at Cuero indicated a decrease in annual median flows from 771,809 acft/yr without the project to 718,641 acft/yr with the project, a 6.9 percent decrease. Although median monthly flow decreased 6.3 percent in January, changes in median monthly flow in the remaining months were not significant. Plotting averages of annual streamflows by deciles indicated small reductions (less than 6 percent) in high flows and no significant changes in the lowest deciles.

Modeling flow changes in the Guadalupe River at the Saltwater Barrier with implementation of Alternative S-15D indicated a decrease in annual medians from 1.07 million acft/yr to 1.0 million acft/yr, (6.3 percent). Except for June and July, reduced flows from month to month in terms of medians were consistent and maintained a pattern of variation similar to that without the project. Although the pattern of variation in monthly flows was maintained and the greatest decreases in volume occurred in high flow deciles, percent flow reductions were greatest in low flow deciles, because reclaimed water represents a greater proportion of the water diverted during low flows compared with that diverted during higher flows.

With respect to the diversion of water from the San Antonio River, modeling of flows near Falls City indicated a reduction in median annual flow from 192,757 acft/yr without the project to 131,578 acft/yr with implementation of the project, a decrease of 31.7 percent. Although the greatest reductions in monthly medians were in the high flow months, significant reductions in median flows occurred in all months. The greatest percent reductions would occur in the low flow deciles because reclaimed water represents a greater proportion of the water diverted in the low flow periods. Streamflows near Falls City with the project would fall below 55,000 acft/yr in five (9 percent) of the 56 years simulated while natural streamflows less than 55,000 acft/yr at this location would have occurred in three (5 percent) of 56 years.

The Academy of Natural Sciences of Philadelphia (ANSP) conducted studies of the macroinvertebrate fauna of the Guadalupe River from 1949 to 1987.⁵⁴ Six sites in Victoria County were surveyed in 1949, 1950, 1952, 1962, 1966, 1973 and 1987. In terms of species richness and abundance, populations of mollusks and crustaceans have remained constant over the sampling period. Dominant species of mollusks and crustaceans include Asiatic clam (*Corbicula*

⁵⁴ Op. Cit., Academy of Natural Sciences, 1991.

fluminea), golden orb (*Quadrula aurea*), Texas lilliput (*Toxolasma texasensis*), grass shrimp (*Palaemonetes spp.*), crayfish (*Procambarus clarkii*), and blue crab (*Callinectes sapidus*).

Kuehne,⁵⁵ Hubbs,⁵⁶ and Lee et. al.,⁵⁷ considered together, provide a comprehensive list of fishes likely to inhabit the San Antonio and Guadalupe Rivers, given appropriate habitats. Hubbs, et. al.⁵⁸ provides an inventory and bibliography dealing with the fishes of Texas. In addition to studying macroinvertebrate communities, ANSP has studied fish communities of the Guadalupe River periodically since 1949. Based on increasing capture records, populations of threadfin shad (*Polydactylus spp.*), green sunfish (*Lepomis cyanellis*), longear sunfish (*L. megalotis*), and warmouth (*L. gulosus*) appear to be increasing in the Guadalupe River. Introduced species including Mexican tetra (*Astyanax mexicanus*), orangespotted sunfish (*L. humilis*), sailfin molly (*Poecilia latipinna*), white crappie (*Pomoxis annularis*), black crappie (*P. nigromaculatus*) and white bass (*Morone chrysops*) also appear to be increasing in abundance.

The construction of diversion dams in the San Antonio, Guadalupe, and Colorado Rivers would convert a portion of the channels into a reservoir environment. Stream impoundment can result in environmental changes (e.g. reduced mixing energy, increased depth) that interact to produce a cascade of effects within and downstream of a newly created reservoir. The actual nature and intensity of these effects are largely dependent on characteristics of the particular site (e.g., reservoir capacity, ratio of depth to surface area, rate of water exchange, nutrient and sediment loading, biological community type). The minimal storage capacity in the pools created by these small diversion dams, however, would not be expected to have significant effects on the downstream flow regime. Any such effects would result from the magnitude and seasonal distribution of the actual diversions. Studies of the reaches to aid in determining the location of intake structures should be conducted in order to avoid critical habitats for spawning and early life stages of fish such as the blue sucker and Guadalupe Bass.

⁵⁵ Kuehne, R.A. 1955. Stream Surveys of the Guadalupe and San Antonio Rivers. IF Report No. 1. Texas Game and Fish Commission. Austin, TX.

⁵⁶ Hubbs, C. 1982. A Checklist of Texas Freshwater Fishes. Tech. Series No. 11:1-12. Texas Parks and Wildlife Department, Austin, Texas.

⁵⁷ Lee, S. L., C.R. Gilbert, C.H. Hocutt, R.E. Jenkins, D.E. McAllister, J.R. Stauffer, Jr. 1980. Atlas of North American Freshwater Fishes. Publ. No. 1980-12 of the North Carolina Biological Survey.

⁵⁸ Hubbs, C., J.D. McEachran and C.R. Smith. 1994. Freshwater and Marine Fishes of Texas and the Northwestern Gulf of Mexico. The Texas System of Natural Laboratories, Inc., Austin, TX.

The possibility of transferring organisms from the Colorado River to the Guadalupe-San Antonio River Basin is likely to be of concern and will need to be addressed. The U.S. Army Corps of Engineers is studying this issue at present.⁵⁹ However, exotic species already inhabit both river systems. Because of the close proximity of these river systems, the presence or absence of appropriate habitats may be a more important isolating mechanism than physical separation of the river drainages.

The Guadalupe-San Antonio Estuary includes a system of freshwater, brackish, and saltwater marshes.⁶⁰ Many plant species found in marshes can tolerate a wide range of salinities and may occur in more than one type of marsh. Other plants may have narrower niche requirements and can be characteristic of a particular type of marsh habitat. Drier, high marshes are characterized by species such as gulf cordgrass (*Spartina spartinae*), paspalum (*Paspalum spp.*), smartweed (*Polygonum spp.*), panic grass (*Panicum spp.*), sea ox-eye daisy (*Borrchia frutescens*), beak rush (*Rhynchospora macrostachya*), sedge (*Fimbristylis spp.*), mexican devilweed (*Aster spinosus*), saltmeadow cordgrass (*Spartina patens*), and scattered bulrush (*Scirpus spp.*), spike rush, and flatsedge. Wetter, low marshes are characterized by cattail (*Typha spp.*), three-square bulrush (*Eleocharis spp.*), flatsedge (*Cyperus spp.*), water hysop (*Bacopa monnieri*), rush (*Juncus spp.*), water primrose (*Ludwigia spp.*), arrowhead (*Sagittaria spp.*), and paspalum (*Paspalum lividum*). Shrubs such as rattlebush (*Sesbania drummondii*), retama (*Parkinsonia aculeata*), and black willow tend to be scattered around the margins of freshwater marshes.

Average inshore catch for all species in the Guadalupe-San Antonio Estuary for the period 1962-1976 exceeded 2.3 million pounds, the third highest out of eight estuaries in Texas. Shrimp accounted for over 90 percent of the bay harvest weight. The shellfish component consists of white shrimp (*Penaeus setiferus*), brown shrimp (*P. aztecus*), blue crab, and eastern bay oyster (*Crassostrea virginica*). The finfish component consists of croaker (*Micropogon undulatus*), spotted seatrout (*Cynoscion nebulosus*), red drum (*Sciaenops ocellata*), black drum (*Pogonias cromis*), sheepshead (*Archosargus probatocephalus*) mullet (*Mugil sp.*), gulf menhaden

⁵⁹ U.S. Army Corps of Engineers. Technical Memorandum. Potential Aquatic Ecological Effects of Two Proposed Interbasin Water Transfers in the South Central Study Area. USACOE, Fort Worth District.

⁶⁰ TPWD, 1992

(*Brevoortia patronus*) flounder (*Paralichthyes sp.*), and sea catfish (*arius felis*).⁶¹ Commercial harvesting of spotted sea trout and red drum has been banned since 1981.

The Guadalupe-San Antonio Estuary also supports a significant sport fishery. Texas Parks and Wildlife Department estimates that harvest of all fish species represents 380,000 fish totaling 420,000 pounds in a single year. Sixty percent of the sport fishery is accounted for by spotted sea trout. Red drum, southern flounder (*P. lethostigma*), black drum, and sand sea trout account for an additional 25 percent of the recreational harvest. Atlantic croaker (*Micropogonias undulatus*), gafftopsail catfish (*Barge marinus*), requiem shark (*Carcharhinidae*), and southern kingfish (*Menticirrhus americanus*) account for five percent of the recreational harvest.

The commercial and sport fish depend upon many estuarine species for survival. Spotted seatrout, southern flounder, and red drum depend on shrimp, pinfish (*Lagodon rhomboides*), menhaden, anchovy (*Anchoa sp.*), and mullet for food. Larval fish depend upon plankton, polychaete worms, and crustaceans for food. Shrimp feed on detritus, polychaetes, epiphytes, and plankton. Gizzard shad (*Dorosoma cepedianum*), striped and white mullet, gulf menhaden, bay anchovy, clams (*Rangia cuneata* and *R. flexuosa*), and eastern bay oyster represent ecologically important species that feed directly on detritus and plankton. Shrimp and small fishes such as pinfish, gulf killifish and longnose killifish (*Fundulus spp.*), sheepshead minnows (*Cyprinodon variegatus*), silversides (*Menidia sp.*), silver perch and juvenile fish are a significant source of food for higher level consumers such as red drum, herons, egrets, porpoise, and spotted sea trout.

Cultural resources protection on public lands in Texas is afforded by the Antiquities Code of Texas (Title 9, Chapter 191, Texas Natural Resource Code of 1977), the National Historic Preservation Act (PL96-515), and the Archeological and Historic Preservation Act (PL93-291). All areas to be disturbed during construction would first be surveyed by qualified professionals to determine the presence or absence of significant cultural resources.

3.46.4 Water Quality and Treatability

[To be completed in subsequent phases of the study.]

⁶¹ TPWD 1991

3.46.5 Engineering and Costing

For this alternative (S-15D), water potentially available for diversion from the various importation sources would be pumped at non-uniform rates to Cibolo Reservoir, which would serve as a storage and balancing reservoir. From Cibolo Reservoir, the firm yield would be pumped at a uniform rate to the proposed South Water Treatment Plant, where it would be treated to drinking water quality prior to delivery. The benefit from these projects would be the addition of a new potable water supply to the San Antonio distribution system and possibly other water supply systems in the surrounding area. The major facilities required to implement these alternatives are:

- Importation Source River Intakes and Pump Stations
- Raw Water Pipelines to Cibolo Reservoir
- Dam and Reservoir
- Reservoir Intake and Pump Station
- Raw Water Pipeline to South Water Treatment Plant
- Raw Water Booster Stations
- South Water Treatment Plant (Level 3; see Section 3.0.2, Volume 2)
- Distribution System Improvements

Optimization analyses were performed to select the appropriate import pipeline size for delivery of water from each potential source to Cibolo Reservoir. These analyses were generally based on selecting the lowest unit cost of additional Cibolo Reservoir firm yield afforded by each import source scenario. Unit costs and incremental unit costs based on the associated additional firm yield were computed for import pipelines ranging in diameter from 12 inches to 120 inches. Unit cost is defined to be the total importation facilities cost for one import pipeline diameter divided by the resultant additional yield, while incremental unit cost is defined to be the incremental importation facilities cost divided by the incremental additional yield obtained by comparison with cost and additional yield for the next smaller diameter. For each importation source scenario, the import pipeline size was generally selected in accordance with the following criteria: 1) Pipeline diameter greater than or equal to that having the least unit cost; and 2) Largest pipeline diameter with a reasonable incremental unit cost.

Optimization analyses for importation from the San Antonio River near Floresville (Alternative S-15Da) were performed first since this was the shortest import pipeline. Once an

import pipeline size was selected for this source, optimization analyses were undertaken to select the appropriate import pipeline size from the Guadalupe River at Cuero to Cibolo Reservoir (Alternative S-15Db). Finally, optimization analyses were performed to select the appropriate import pipeline size from the Colorado River to Cuero and the appropriate increase in import pipeline size from Cuero to Cibolo Reservoir (Alternative S-15Dc).

For each source scenario or alternative, costs for the selected importation facilities were combined with costs for Cibolo Dam and Reservoir (see Section 3.15, Volume 2), other major facilities listed above, and related project costs (land acquisition, mitigation, engineering, etc.) to obtain Total Project Cost. Total Project Cost was then converted to annual debt service (25 year finance period at 8 percent interest) and combined with related operations and maintenance and power costs to obtain Total Annual Cost. Cost estimates for each importation source scenario subject to original Trans-Texas Environmental Criteria are summarized in Table 3.46-2 and discussed in the following subsections.

Alternative S-15Da: Import from San Antonio River

Cibolo Reservoir operated in conjunction with available water imported from the San Antonio River near Floresville could provide a firm yield of about 75,600 acft/yr at an annual cost of \$703/acft. This firm yield and annual cost are based on a 72-inch diameter import pipeline from the San Antonio River and a 66-inch transmission pipeline from Cibolo Reservoir to the proposed South Water Treatment Plant. The information used to select the 72-inch diameter import pipeline from the San Antonio River to Cibolo Reservoir is illustrated in Figure 3.46-4.

Key observations upon consideration of Figure 3.46-4 are summarized as follows:

- 1) With a maximum diversion rate of about 102,000 acft/yr (140 cfs), a 72-inch diameter import pipeline could enhance the firm yield of Cibolo Reservoir by about 43,300 acft/yr. Very little additional yield can be obtained with larger diameter import pipelines based on 1988 return flow quantities.
- 2) On the sole basis of unit cost for importation facilities, a 48-inch diameter import pipeline (\$68/acft/yr) could be selected rather than a 72-inch diameter import pipeline (\$80/acft/yr).
- 3) Considering incremental unit cost for importation facilities, it is clear that the import pipeline could be "up-sized" to a 72-inch diameter as additional yield relative to the next smaller diameter costs \$216/acft/yr which is still a reasonable unit cost of water. "Up-sizing" to an 84-inch diameter, however, would not be recommended as the additional yield costs more than \$800/acft/yr.

Table 3.46-2
Cost Estimates for Cibolo Reservoir with Imported Water
from the San Antonio, Guadalupe, and Colorado Rivers (S-15D)
(Original Trans-Texas Environmental Criteria)
(Mid 1994 Prices)

Item	Import San Antonio River Water (S-15Da)	Import San Antonio and Guadalupe River Water (S-15Db)	Import San Antonio, Guadalupe, and Colorado ¹ River Water (S-15Dc)
Capital Costs			
Dam and Reservoir	\$114,430,000	\$114,430,000	\$114,430,000
Transmission and Pumping	63,720,000	125,120,000	322,930,000
Treatment Plant	30,000,000	32,000,000	58,000,000
Delivery System	<u>54,590,000</u>	<u>59,130,000</u>	<u>93,960,000</u>
Total Capital Cost	\$262,740,000	\$330,680,000	\$589,320,000
Engineering, Contingencies, and Legal Costs	84,090,000	104,940,000	183,070,000
Land Acquisition	34,100,000	34,440,000	35,270,000
Environmental Studies and Mitigation	29,990,000	31,330,000	33,160,000
Interest During Construction	<u>25,920,000</u>	<u>29,590,000</u>	<u>43,870,000</u>
Total Project Cost	\$436,840,000	\$530,980,000	\$884,690,000
Annual Costs			
Annual Debt Service	\$ 40,930,000	\$ 49,750,000	\$ 82,890,000
Annual Operation and Maintenance	7,440,000	8,630,000	15,720,000
Annual Power Cost	<u>4,760,000</u>	<u>6,210,000</u>	<u>17,470,000</u>
Total Annual Cost	\$53,130,000	\$64,590,000	\$116,080,000
Available Project Yield (acft/yr)	75,600	79,600	162,900
Annual Cost of Water (\$/acft/yr)	\$703	\$811	\$713

¹ Available water from the Colorado River near Columbus estimated without application of environmental criteria for run-of-the-river diversions.

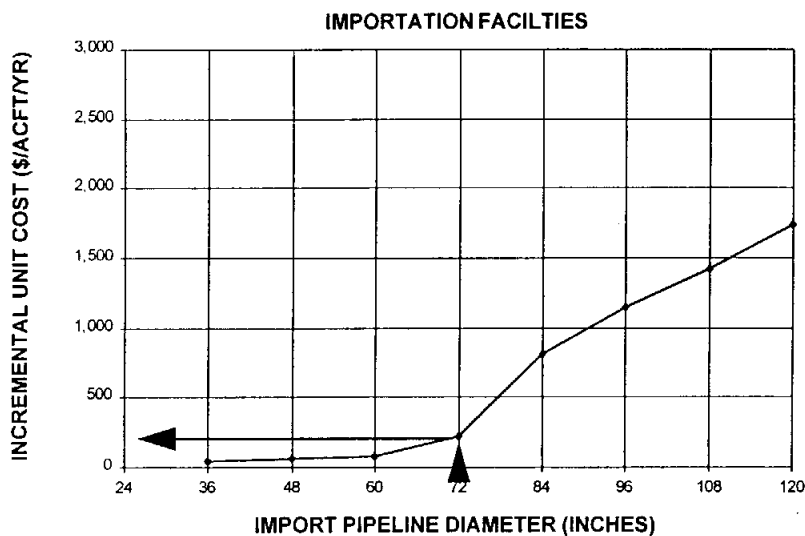
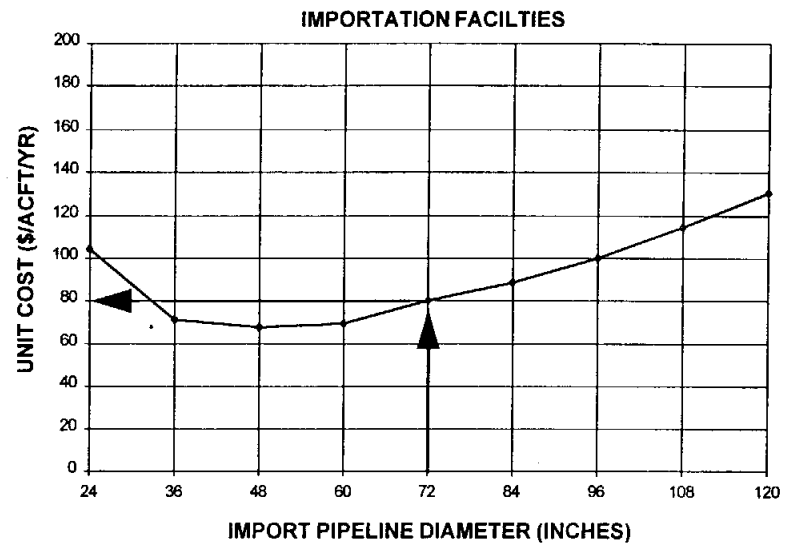
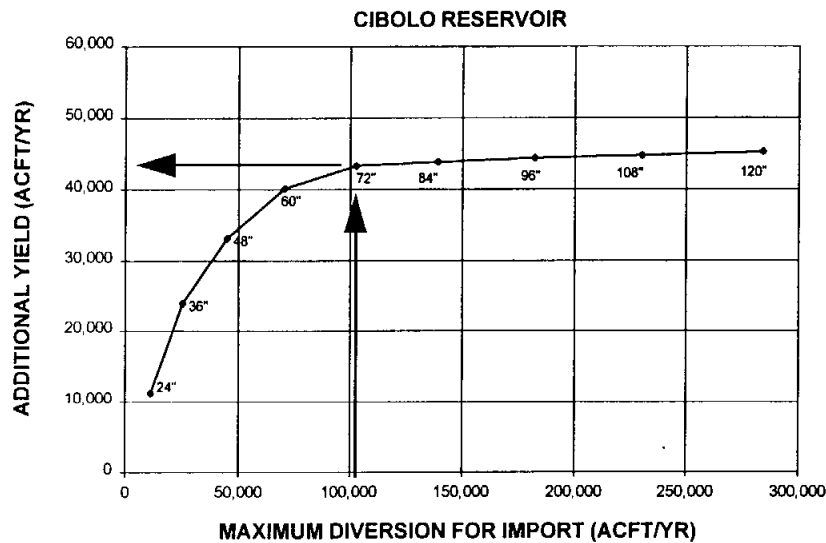

ASSUMPTIONS:

1. SPRING FLOWS RESULTING FROM FIXED EDWARDS AQUIFER PUMPAGE OF 400,000 ACFT/YR.
2. HYDROPOWER WATER RIGHTS FULLY SUBORDINATED TO CANYON LAKE.
3. UNCOMMITTED FIRM YIELD OF CANYON LAKE DIVERTED NEAR NEW BRAUNFELS.
4. RETURN FLOWS SET AT RATES OBSERVED IN 1988.
5. IMPORTS INCLUDE SAWS RECLAIMED WATER AND UNAPPROPRIATED STREAMFLOW SUBJECT TO ORIGINAL TRANS-TEXAS ENVIRONMENTAL CRITERIA.

TRANS TEXAS WATER PROGRAM /
WEST CENTRAL STUDY AREA



**OPTIMIZATION SUMMARY
SAN ANTONIO RIVER ONLY
ALTERNATIVE S-15D**

Alternative S-15Db: Import from San Antonio and Guadalupe Rivers

Cibolo Reservoir operated in conjunction with available water imported from the San Antonio River near Floresville and the Guadalupe River at Cuero could provide a firm yield of about 79,600 acft/yr at an annual cost of \$811/acft. This firm yield and annual cost are based on a 72-inch diameter import pipeline from the San Antonio River, an 84-inch import pipeline from the Guadalupe River, and a 66-inch transmission pipeline from Cibolo Reservoir to the proposed South Water Treatment Plant. The information used to select the 84-inch diameter import pipeline from the Guadalupe River to Cibolo Reservoir is illustrated in Figure 3.46-5. Key observations upon consideration of Figure 3.46-5 are summarized as follows:

1. With a maximum diversion rate of about 139,000 acft/yr (190 cfs), an 84-inch diameter import pipeline could enhance the firm yield of Cibolo Reservoir by only about 4,000 acft/yr. Additional yield due to importation from the Guadalupe River is rather limited due to the diversion of only unappropriated streamflow subject to the original Trans-Texas Environmental Criteria.
2. As the unit costs associated with importation from the Guadalupe River were rather high (in excess of \$2,500/acft/yr), the 84-inch diameter import pipeline was selected based on minimum incremental unit cost.

Alternative S-15Dc: Import from San Antonio, Guadalupe, and Colorado Rivers

Cibolo Reservoir operated in conjunction with available water imported from the San Antonio River near Floresville, the Guadalupe River at Cuero, and the Colorado River near Columbus could provide a firm yield of about 162,900 acft/yr at an annual cost of \$713/acft. This firm yield and annual cost are based on a 72-inch diameter import pipeline from the San Antonio River, two 90-inch import pipelines from the Guadalupe River, a 96-inch diameter import pipeline from the Colorado River, and a 96-inch transmission pipeline from Cibolo Reservoir to the proposed South Water Treatment Plant. This is the importation source scenario presented in Figure 3.46-1. The information used to select the 96-inch diameter import pipeline from the Colorado River to Cuero (and the two 90-inch diameter import pipelines from Cuero to Cibolo Reservoir) is illustrated in Figure 3.46-6. Key observations upon consideration of Figure 3.46-6 are summarized as follows:

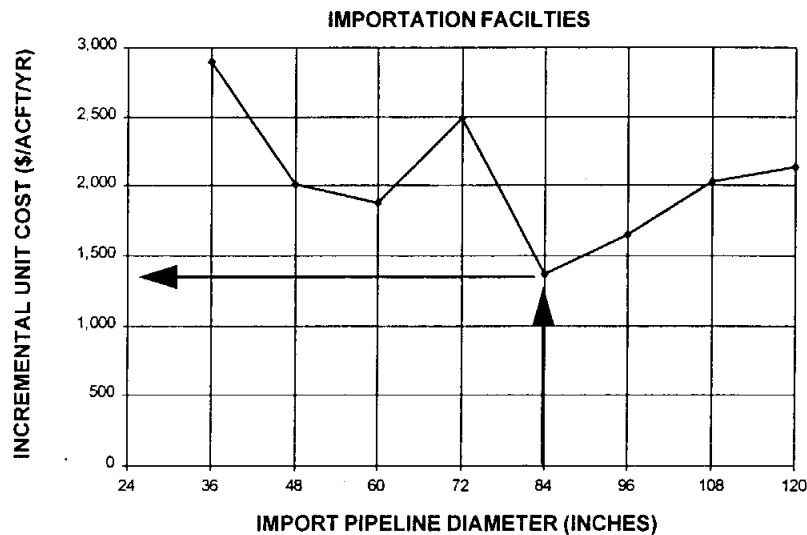
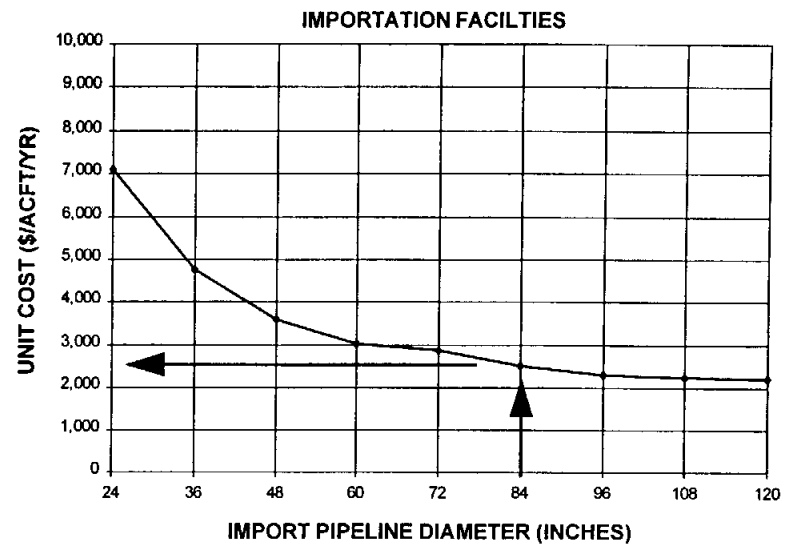
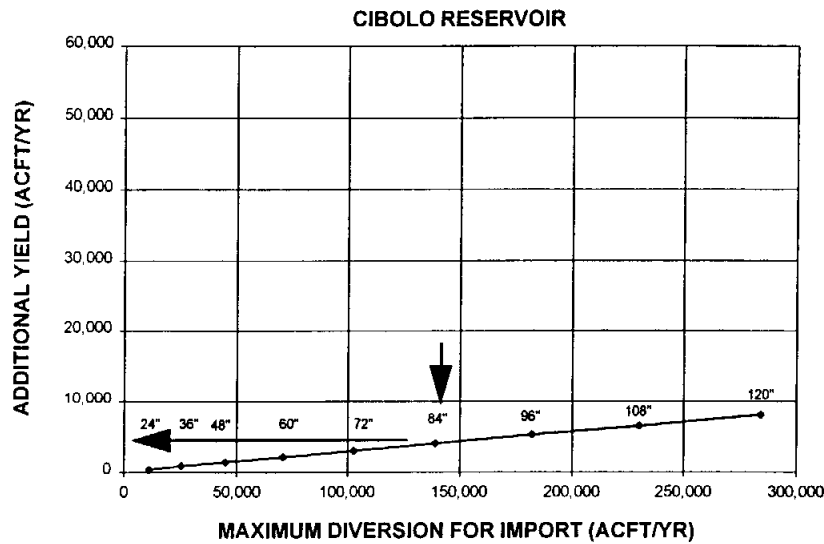

ASSUMPTIONS:

1. SPRING FLOWS RESULTING FROM FIXED EDWARDS AQUIFER PUMPAGE OF 400,000 ACFT/YR.
2. HYDROPOWER WATER RIGHTS FULLY SUBORDINATED TO CANYON LAKE.
3. UNCOMMITTED FIRM YIELD OF CANYON LAKE DIVERTED NEAR NEW BRAUNFELS.
4. RETURN FLOWS SET AT RATES OBSERVED IN 1988.
5. IMPORTS INCLUDE UNAPPROPRIATED STREAMFLOW SUBJECT TO ORIGINAL TRANS-TEXAS ENVIRONMENTAL CRITERIA.

TRANS TEXAS WATER PROGRAM /
WEST CENTRAL STUDY AREA



HDR Engineering, Inc.

**OPTIMIZATION SUMMARY
WITH GUADALUPE RIVER
ALTERNATIVE S-15D**

FIGURE 3.46-5

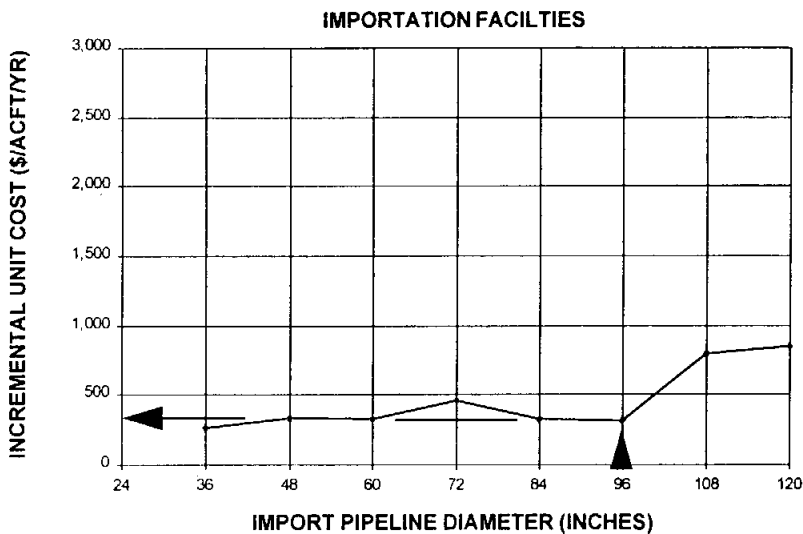
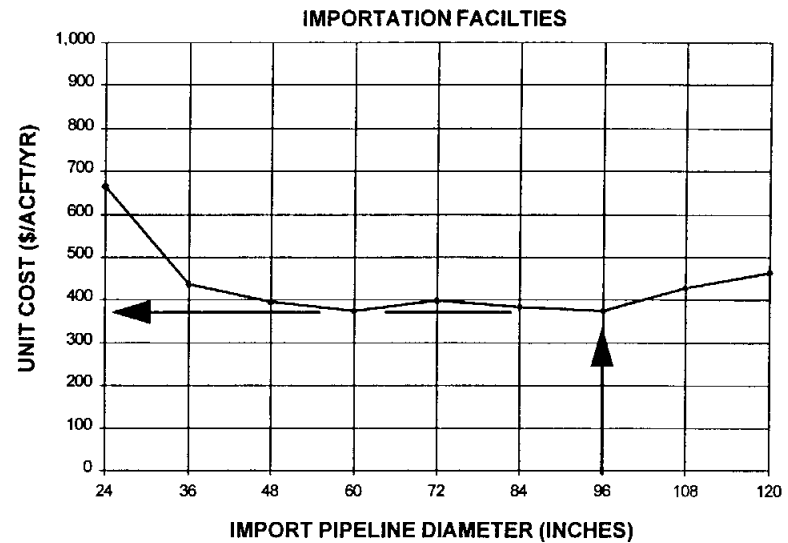
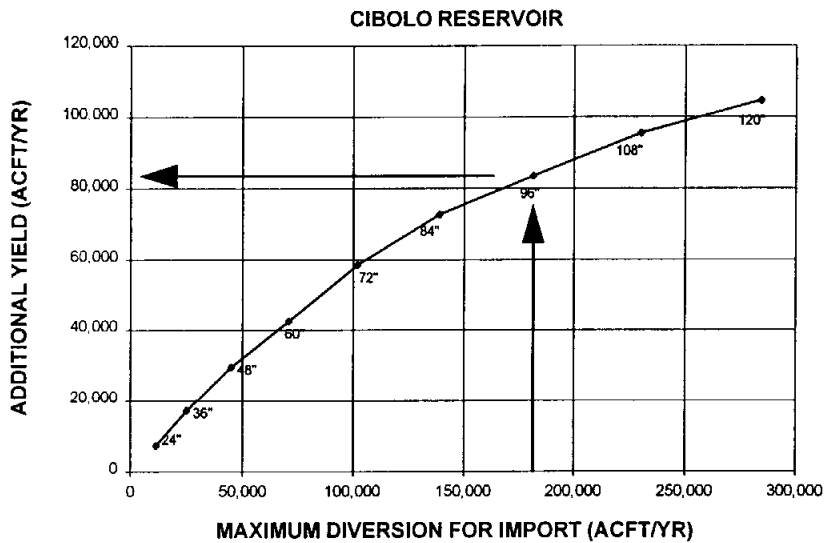

ASSUMPTIONS:

1. CITY OF AUSTIN RETURN FLOWS INCLUDED AT 55 PERCENT OF AUTHORIZED ANNUAL DIVERSION RIGHTS.
2. IMPORTS INCLUDE UNAPPROPRIATED STREAMFLOW WITHOUT APPLICATION OF ENVIRONMENTAL CRITERIA.

TRANS TEXAS WATER PROGRAM /
WEST CENTRAL STUDY AREA



HDR Engineering, Inc.

**OPTIMIZATION SUMMARY
WITH COLORADO RIVER
ALTERNATIVE S-15D**

FIGURE 3.46-6

1. With a maximum diversion rate of about 182,000 acft/yr (250 cfs), a 96-inch diameter import pipeline (and upsizing the pipeline from Cuero to Cibolo Reservoir) could enhance the firm yield of Cibolo Reservoir by about 83,300 acft/yr. Actual additional yield due to importation of unappropriated streamflow from the Colorado River could be reduced significantly by the application of environmental criteria for instream flows or for freshwater inflows to bays and estuaries. Importation of water potentially available under existing rights in the Colorado Basin, however, might increase water availability.
2. Considering incremental unit cost for importation facilities, the additional yield for the 96-inch diameter relative to the next smaller diameter costs \$318/acft/yr. "Up-sizing" to an 108-inch diameter, however, would not be recommended as the additional yield costs more than \$800/acft/yr.

Consideration of Alternative Trans-Texas Environmental Criteria

For comparison purposes, unappropriated streamflow potentially available for diversion from the San Antonio and Guadalupe Rivers and importation to Cibolo Reservoir was evaluated subject to alternative Trans-Texas Environmental Criteria for run-of-the-river diversions⁶² based on assumed import pipelines ranging in diameter from 12 inches to 120 inches. The resultant additional yields of Cibolo Reservoir and associated importation facility costs formed the basis of optimization analyses performed to select the import pipeline size for delivery of water from each potential source. Optimization analyses are summarized in Figures 3.46-7 and 3.46-8 and cost estimates are summarized in Table 3.46-3 for two importation source scenarios comparable to Alternatives S-15Da and S-15Db.

Cibolo Reservoir operated in conjunction with available water imported from the San Antonio River near Floresville could provide a firm yield of about 80,600 acft/yr at an annual cost of \$682/acft. This firm yield and annual cost are based on an 84-inch diameter import pipeline from the San Antonio River and a 66-inch transmission pipeline from Cibolo Reservoir to the proposed South Water Treatment Plant. The firm yield would be almost 7 percent greater and the unit cost about 3 percent less than comparable values under original Trans-Texas Environmental Criteria.

Cibolo Reservoir operated in conjunction with available water imported from the San Antonio River near Floresville and the Guadalupe River at Cuero could provide a firm yield of about 106,100 acft/yr at an annual cost of \$725/acft. This firm yield and annual cost are based on

⁶² Op. Cit., HDR, June, 1995.

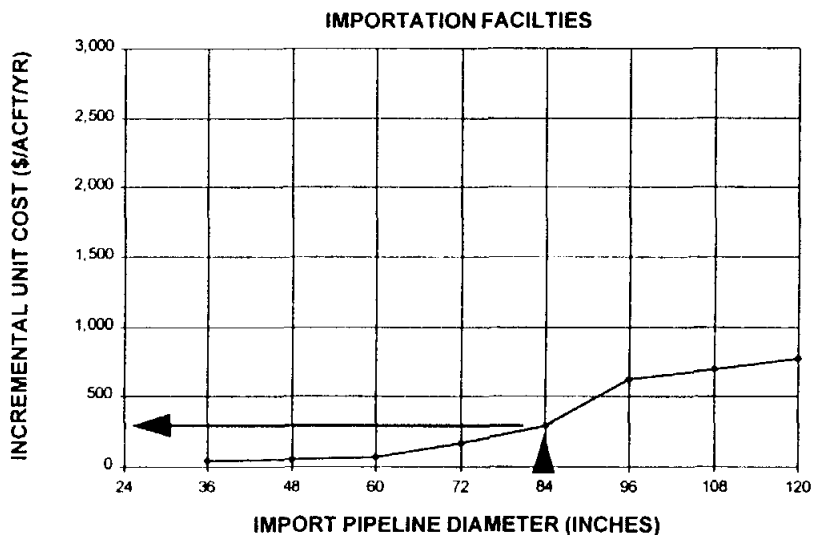
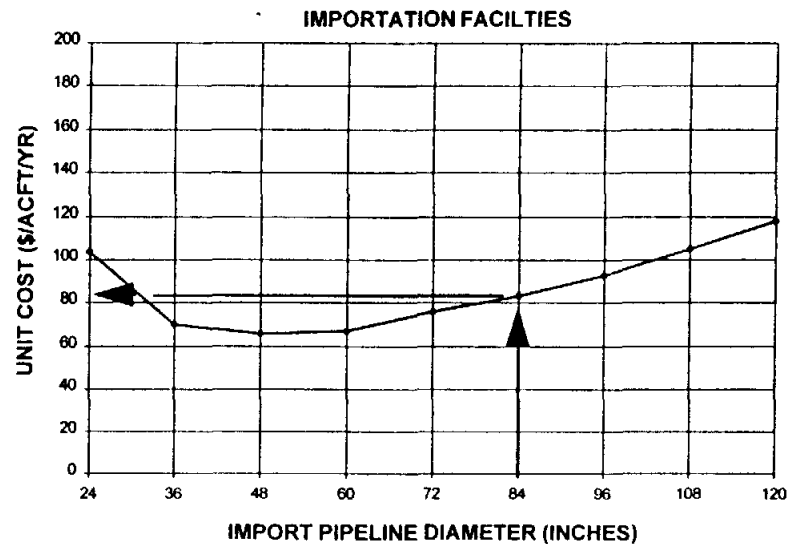
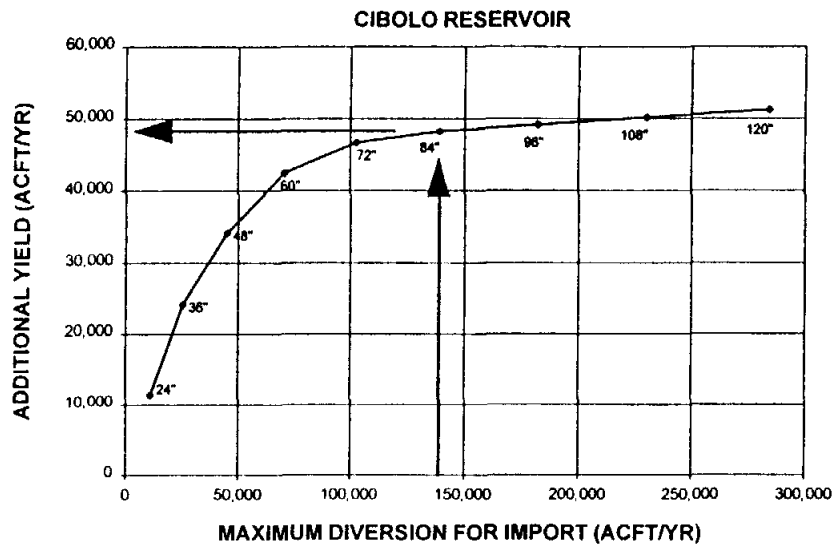

ASSUMPTIONS:

1. SPRING FLOWS RESULTING FROM FIXED EDWARDS AQUIFER PUMPAGE OF 400,000 ACFT/YR.
2. HYDROPOWER WATER RIGHTS FULLY SUBORDINATED TO CANYON LAKE.
3. UNCOMMITTED FIRM YIELD OF CANYON LAKE DIVERTED NEAR NEW BRAUNFELS.
4. RETURN FLOWS SET AT RATES OBSERVED IN 1988.
5. IMPORTS INCLUDE SAWS RECLAIMED WATER AND UNAPPROPRIATED STREAMFLOW SUBJECT TO ALTERNATIVE TRANS-TEXAS ENVIRONMENTAL CRITERIA.

TRANS TEXAS WATER PROGRAM /
WEST CENTRAL STUDY AREA



HDR Engineering, Inc.

**OPTIMIZATION SUMMARY
SAN ANTONIO RIVER ONLY
ALT. ENVIRONMENTAL CRITERIA**

FIGURE 3.46-7

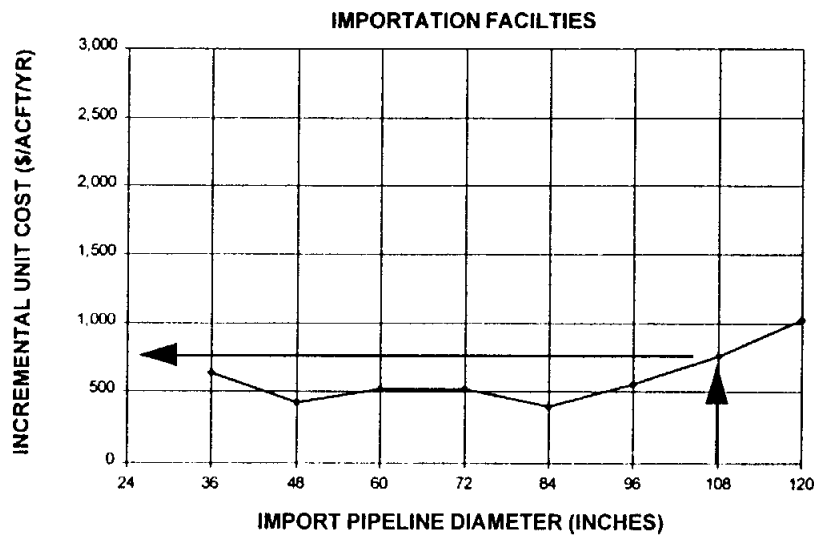
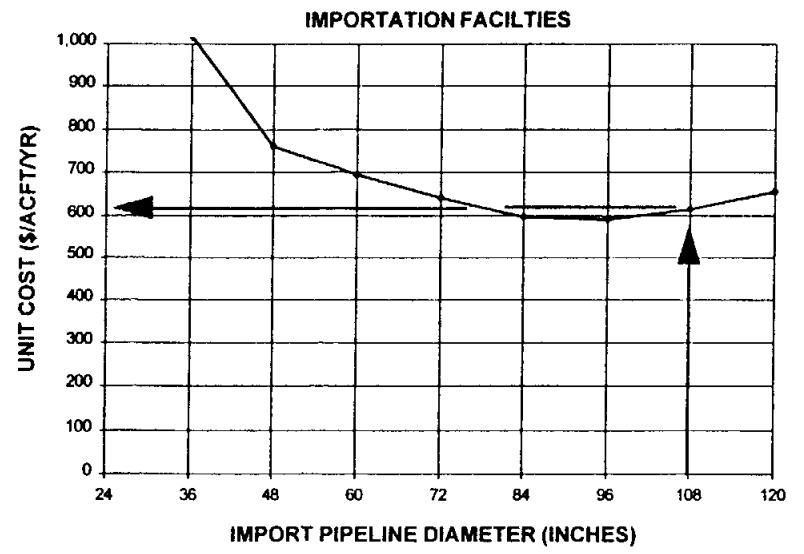
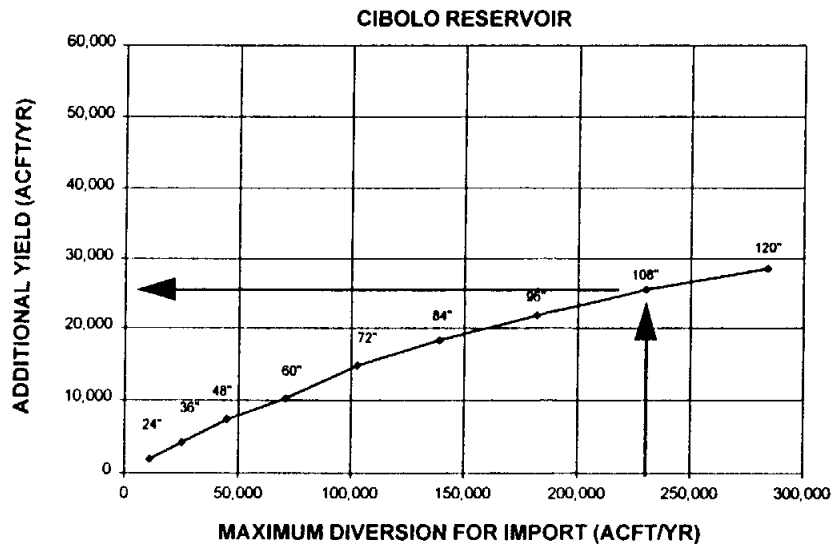

ASSUMPTIONS:

1. SPRING FLOWS RESULTING FROM FIXED EDWARDS AQUIFER PUMPAGE OF 400,000 ACFT/YR.
2. HYDROPOWER WATER RIGHTS FULLY SUBORDINATED TO CANYON LAKE.
3. UNCOMMITTED FIRM YIELD OF CANYON LAKE DIVERTED NEAR NEW BRAUNFELS.
4. RETURN FLOWS SET AT RATES OBSERVED IN 1988.
5. IMPORTS INCLUDE UNAPPROPRIATED STREAMFLOW SUBJECT TO ALTERNATIVE TRANS-TEXAS ENVIRONMENTAL CRITERIA.

TRANS TEXAS WATER PROGRAM /
WEST CENTRAL STUDY AREA



HDR Engineering, Inc.

OPTIMIZATION SUMMARY
WITH GUADALUPE RIVER
ALT. ENVIRONMENTAL CRITERIA

FIGURE 3.46-8

Table 3.46-3 Cost Estimates for Cibolo Reservoir with Imported Water from the San Antonio and Guadalupe Rivers (S-15D) (Alternative Trans-Texas Environmental Criteria for Run-of-the-River Diversions) (Mid 1994 Prices)		
Item	Import San Antonio River Water	Import San Antonio & Guadalupe River Water
Capital Costs		
Dam and Reservoir	\$114,430,000	\$114,430,000
Transmission and Pumping	66,190,000	170,610,000
Treatment Plant	32,000,000	39,000,000
Delivery System	<u>56,600,000</u>	<u>68,220,000</u>
Total Capital Cost	\$269,220,000	\$392,260,000
Engineering, Contingencies, and Legal Costs	86,070,000	123,520,000
Land Acquisition	34,100,000	34,440,000
Environmental Studies and Mitigation	29,980,000	31,340,000
Interest During Construction	<u>26,310,000</u>	<u>32,980,000</u>
Total Project Cost	\$445,680,000	\$614,540,000
Annual Costs		
Annual Debt Service	\$41,760,000	\$57,580,000
Annual Operation and Maintenance	7,880,000	10,720,000
Annual Power Cost	<u>5,330,000</u>	<u>8,580,000</u>
Total Annual Cost	\$54,970,000	\$76,880,000
Available Project Yield (acft/yr)	80,600	106,100
Annual Cost of Water (\$/acft/yr)	\$682	\$725

an 84-inch diameter import pipeline from the San Antonio River, an 108-inch import pipeline from the Guadalupe River, and a 78-inch transmission pipeline from Cibolo Reservoir to the proposed South Water Treatment Plant. The firm yield would be 33 percent greater and the unit cost about 11 percent less than comparable values under original Trans-Texas Environmental Criteria. It is interesting to note that unit costs for an 108-inch pipeline from the Guadalupe River to Cibolo

Reservoir decrease from about \$2,300/acft/yr under the original Trans-Texas Environmental Criteria to about \$613/acft/yr under the alternative criteria for run-of-the-river diversions. This represents about a 73 percent decrease in unit cost for this component of the project due to increased water availability during the drought.

3.46.6 Implementation Issues

An institutional arrangement is needed to implement projects including financing on a regional basis.

Cibolo Reservoir and Channel Dams

1. It will be necessary to obtain these permits:
 - a. TNRCC Water Right and Storage permits.
 - b. U.S. Army Corps of Engineers Sections 10 and 404 dredge and fill permits for Cibolo Reservoir, the channel dams, and intake structures.
 - c. GLO Sand and Gravel Removal permits.
 - d. GLO Easement for use of state-owned land.
 - e. Coastal Coordination Council review.
 - f. TPWD Sand, Gravel, and Marl permit.
2. Permitting, at a minimum, will require these studies:
 - a. Bay and estuary inflow impact.
 - b. Habitat mitigation plan.
 - c. Environmental studies.
 - d. Cultural resource studies.
3. Land will need to be acquired through either negotiations or condemnation.
4. Relocations for the reservoir include:
 - a. Highways and railroads.
 - b. Other utilities.

Requirements Specific to Diversion of Water from San Antonio River

1. Necessary permits:
 - a. TNRCC permit to divert unappropriated water.
 - b. TNRCC bed and banks permit for use of affected reaches of San Antonio River to deliver private water from SAWS return flows.
 - c. TNRCC Interbasin Transfer Approval.
2. Permitting will require these studies:
 - a. Instream flow issues and impact.
 - b. Environmental studies.
 - c. Bay and estuary inflow issues.
3. Water demand reduction programs by the San Antonio Water System may reduce the quantity of future return flows.

4. Use of return flows must be negotiated with the San Antonio Water System. Use arrangements should consider drought contingency planning that may result in a reduction of return flows by the San Antonio Water System.
5. Water compatibility testing, including biological and chemical characteristics will need to be performed.

Requirements Specific to Diversion of Water from Guadalupe and Colorado Rivers

1. Necessary permits:
 - a. TNRCC permit to divert unappropriated water.
 - b. TNRCC Interbasin Transfer Approval.
2. Permitting will require these studies:
 - a. Instream flow issues and impact.
 - b. Environmental studies.
 - c. Bay and estuary inflow issues.

Requirements Specific to Pipelines

1. Necessary permits:
 - a. U.S. Army Corps of Engineers Sections 10 and 404 dredge and fill permits for stream crossings.
 - b. GLO Sand and Gravel Removal permits.
 - c. Coastal Coordination Council review.
 - d. TPWD Sand, Gravel, and Marl permit.
2. Right-of-way and easement acquisition.
3. Crossings:
 - a. Highways and railroads.
 - b. Creeks and rivers.
 - c. Other utilities.

Requirements Specific to Treatment and Distribution

1. Detailed study needed of the cost of pumping and transmission pipeline improvements necessary to effectively integrate the new supply into the San Antonio water supply system.
2. Study needed of cost to convey and distribute water to other area water utilities.

3.47 Cibolo Reservoir with Imported Water from the Saltwater Barrier and Colorado River (S-15E)

3.47.1 Description of Alternative

Cibolo Reservoir is a proposed impoundment on Cibolo Creek in Wilson County located about 8 miles east of Floresville. The project has been studied by the U.S. Bureau of Reclamation (USBR)^{63,64}, and more recently, by Espey, Huston, and Associates, Inc. (EHA) which studied two potential dam sites in 1986⁶⁵. The more downstream of the two sites which would provide the greater storage capacity has been selected for consideration in the Trans-Texas Water Program. An evaluation of Cibolo Reservoir using only runoff from the Cibolo Creek watershed was presented in Section 3.15 of Volume 2 of this Phase I Interim Report.

Cibolo Reservoir has a proposed conservation capacity of about 409,700 acft below elevation 416 ft-MSL. As noted in Section 3.15 of Volume 2 (see Figure 3.15-2), the reservoir would fill only infrequently with runoff from the Cibolo Creek watershed leaving ample capacity available for storage of water from other sources. Hence, Alternative S-15E includes importation of unappropriated water from the Guadalupe River at the Saltwater Barrier (located below the confluence of the San Antonio River and near Tivoli) and from the Colorado River to Cibolo Reservoir through a system of river intakes, pump stations, and pipelines shown in Figure 3.47-1. Unappropriated water from the Colorado River would be diverted below Garwood, released into Sandy Creek for delivery to Lake Texana, and delivered via transmission pipeline to join the import pipeline from the Saltwater Barrier to Cibolo Reservoir. The enhanced firm yield of Cibolo Reservoir would then be delivered to the proposed South Water Treatment Plant for distribution to municipal water systems in the San Antonio. Two independent importation source scenarios for Cibolo Reservoir have been studied and are described as follows:

- S-15Ea Importing water from the Guadalupe River at the Saltwater Barrier; and
- S-15Eb Importing water from the Guadalupe River at the Saltwater Barrier and the Colorado River below Garwood.

⁶³ U.S. Bureau of Reclamation (USBR), "Feasibility Report, Cibolo Project, Texas," February, 1971.

⁶⁴ USBR, "Texas Basins Project," February, 1965.

⁶⁵ Espey, Huston, and Associates, Inc., "Water Availability Study for the Guadalupe and San Antonio River Basins," February, 1986.

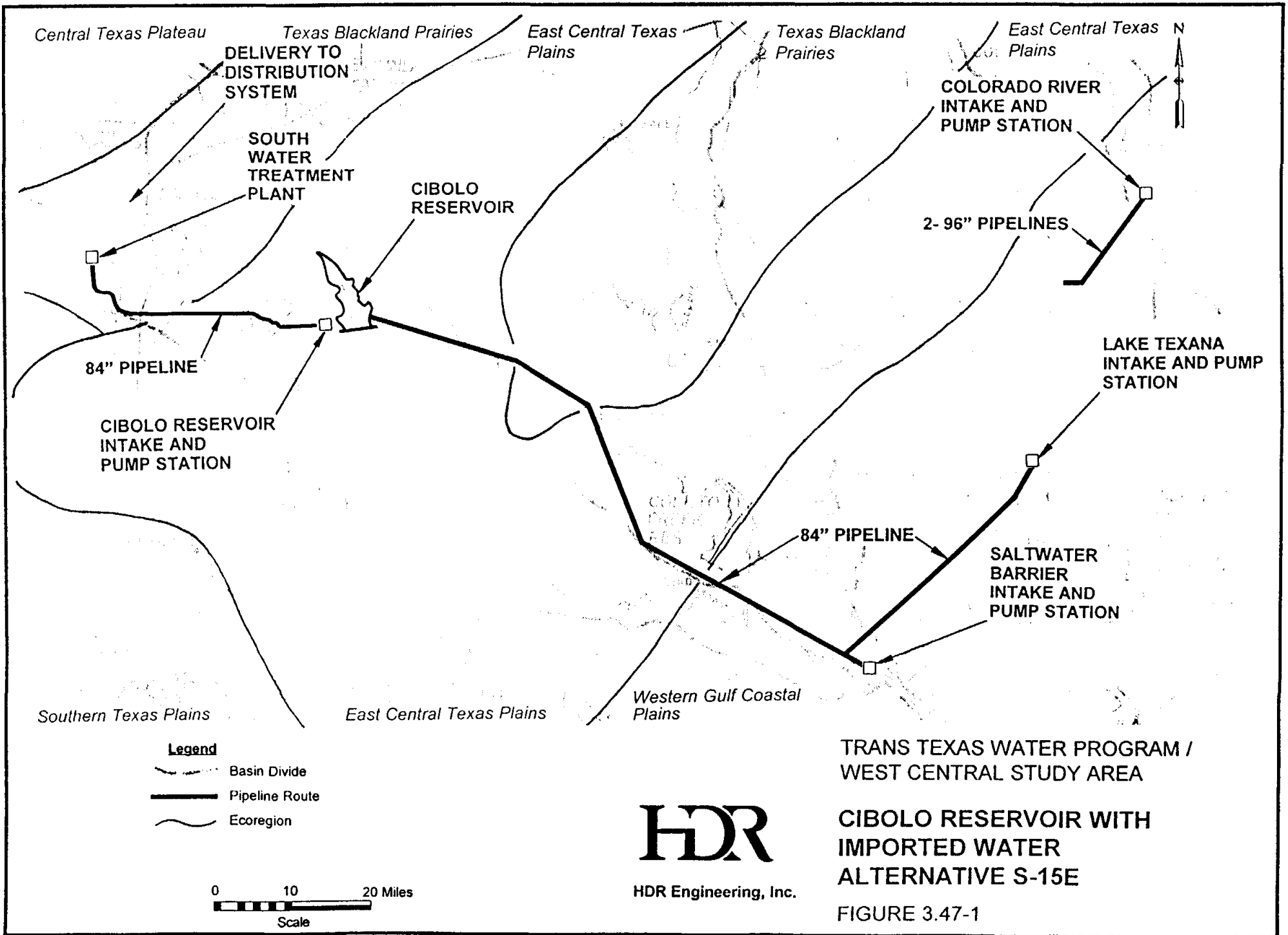

DELIVERY TO DISTRIBUTION SYSTEM

SOUTH WATER TREATMENT PLANT

CIBOLO RESERVOIR

COLORADO RIVER INTAKE AND PUMP STATION

2- 96" PIPELINES

84" PIPELINE



LAKE TEXANA INTAKE AND PUMP STATION

CIBOLO RESERVOIR INTAKE AND PUMP STATION

84" PIPELINE

SALTWATER BARRIER INTAKE AND PUMP STATION

Legend

-  Basin Divide
-  Pipeline Route
-  Ecoregion

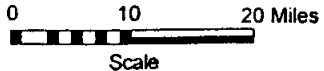

HDR
HDR Engineering, Inc.

TRANS TEXAS WATER PROGRAM / WEST CENTRAL STUDY AREA

CIBOLO RESERVOIR WITH IMPORTED WATER ALTERNATIVE S-15E

FIGURE 3.47-1

3.47.2 Available Yield

Water potentially available for impoundment in the proposed Cibolo Reservoir and for importation from the Saltwater Barrier was estimated using the Guadalupe - San Antonio River Basin Model⁶⁶ (GSA Model) using a 1934-89 period of record. The GSA Model estimates monthly quantities of total streamflow and unappropriated streamflow available at the reservoir site and points of diversion for importation. For modeling purposes, water availability in the Guadalupe - San Antonio River Basin was estimated at the following locations:

- Cibolo Creek near Falls City (ID #1860); and
- Guadalupe River near Tivoli (ID #1888).

Estimates of water potentially available for diversion or impoundment in the Guadalupe - San Antonio River Basin were computed subject to original Trans-Texas Environmental Criteria for Instream Flows and Freshwater Inflows to Bays and Estuaries (Appendix C, Volume 2) and include springflows resulting from a fixed Edwards Aquifer pumpage rate of 400,000 acft/yr with existing recharge structures, full utilization of existing water rights, and hydropower water rights fully subordinated to Canyon Lake.

The water availability analyses proceeded in a sequential manner, starting at the Saltwater Barrier and, then, adding unappropriated water potentially available from the Colorado River below Garwood. Water potentially available for diversion at the Saltwater Barrier was computed assuming reuse of available San Antonio Water System (SAWS) treated effluent. The GSA Model was used to estimate monthly SAWS effluent quantities arriving at the Saltwater Barrier after consideration of other uses for reclaimed water including the Tunnel Reuse Project and make-up water for Braunig and Calaveras Lakes. Assuming diversion of available SAWS effluent, unappropriated streamflows were then estimated subject to environmental criteria using the GSA Model. The monthly sum of unappropriated streamflow and SAWS effluent determined total availability at the Saltwater Barrier. Daily gaged flows for the San Antonio River near Falls City (ID#1835) (1934-89 period) and for the Guadalupe River at Cuero (ID#1758) (1964-89 period) were analyzed in order to determine a typical percentage of water available on a monthly basis which could be diverted on a daily basis subject to reuse of SAWS treated effluent,

⁶⁶ HDR Engineering, Inc., "Guadalupe- San Antonio River Basin Recharge Enhancement Study," Volumes I, II, and III, Edwards Underground Water District, September, 1993.

downstream water rights, selected diversion rates, and daily streamflow variations. These analyses indicated that, on average, 80 percent and 85 percent of the monthly volume of the streamflow available for diversion from Cuero and Falls City, respectively, could be diverted considering the daily distribution of flows. Because most of the streamflow at the Saltwater Barrier is contributed by the Guadalupe River and the Saltwater Barrier is more than 150 river miles further away from SAWS treated effluent discharge locations than the streamflow gage at Falls City, maximum monthly diversions to Cibolo Reservoir were limited to 80 percent of the estimated water available at the Saltwater Barrier.

Unappropriated streamflow potentially available from the Colorado River below Garwood was estimated on a daily timestep using the Colorado River Daily Allocation Program (DAP). This computer model was developed by the Lower Colorado River Authority (LCRA) and applied by LCRA staff to estimate unappropriated water potentially available for diversion. The model simulates flows in the Colorado River and allocates these flows to diverters, based on seniority of water rights, for a 1941-65 period of record. Water availability estimates from the Colorado River presented in this study were not subjected to Trans-Texas Environmental Criteria and may overstate quantities of unappropriated streamflow.

Import pipeline capacity for diversion of unappropriated water from the Colorado River below Garwood to Sandy Creek was selected based on approximations of the resultant increase in firm yield at Lake Texana. Based on analyses performed in the Trans-Texas Water Program for the Corpus Christi Service Area⁶⁷, it was assumed that the firm yield of Lake Texana would be increased by an amount equal to approximately 85 percent of the annual average quantity of water imported to Sandy Creek during the 1954-56 critical drought period for Lake Texana. This 85 percent factor accounts for losses incurred in delivery via Sandy Creek, the seasonal diversion pattern from the Colorado River, and evaporation losses in Lake Texana. A maximum Colorado River diversion capacity of about 23,500 acft/month (390 cfs) was selected as additional capacity would not further enhance the firm yield of Lake Texana to a significant degree. Selection of this maximum capacity results in an increase of about 66,700 acft/yr in the firm yield of Lake Texana

⁶⁷ HDR Engineering, Inc., "Trans-Texas Water Program, Corpus Christi Service Area. Phase I Interim Report," Volume 1, Lavaca-Navidad River Authority, August, 1993.

which would be delivered at a uniform monthly rate to the import pipeline extending from the Saltwater Barrier to Cibolo Reservoir.

The GSA Model was used to estimate monthly quantities of total streamflow and unappropriated streamflow potentially available at Cibolo Reservoir. For modeling purposes, streamflows for Cibolo Creek near Falls City (ID#1860) were assumed to be representative of inflows to the reservoir. The firm yield of the proposed Cibolo Reservoir with and without imported water was computed using an original model (RESSIM) specifically written to simulate reservoir operations subject to Trans-Texas Environmental Criteria for New Reservoirs. The firm yield of Cibolo Reservoir based solely on runoff from the Cibolo Creek watershed (see Section 3.15, Volume 2) is estimated to be about 32,300 acft/yr for a drought trigger at 60 percent of storage capacity. This yield estimate serves as the baseline to which enhanced yield estimates for the two importation source scenarios previously listed are compared.

Optimization analyses considering a range of potential import pipeline diameters were performed to select the most appropriate importation facilities based on minimum unit cost and reasonable incremental unit cost of additional Cibolo Reservoir firm yield. These optimization analyses are presented in greater detail in Section 3.47.5. Total system firm yield estimates for Cibolo Reservoir with selected importation facilities under each scenario are summarized in Table 3.47-1.

3.47.3 Environmental Issues

The proposed Cibolo Reservoir near Stockdale (Alternative S-15) has been described previously (Section 3.15, Volume 2), hence, the following discussion focuses on issues relevant to diverting water from the Guadalupe and Colorado Rivers, and the import pipelines required to transport it to the proposed Cibolo Reservoir. The proposed Colorado River diversion would involve delivery of water to Lake Texana via Sandy Creek. From Lake Texana water then would be delivered by pipeline to Cibolo Reservoir (Figure 3.47-1) along with additional water diverted from the Guadalupe River at the Saltwater Barrier. The Trans-Texas Water Program, Corpus Christi Service Area, Phase II report considered the same diversion point on the Colorado River, a pipeline to Sandy Creek, and a pipeline from Lake Texana to McFaddin as a water supply

Table 3.47-1 Summary of Firm Yield Estimates Cibolo Reservoir with Imported Water from the Saltwater Barrier and Colorado River (S-15E)	
Sources of Imported Water to Cibolo Reservoir	Total Firm Yield (acft/yr) ¹
Baseline: Cibolo Reservoir yield without Imported Water	32,300
Guadalupe River at Saltwater Barrier (S-15Ea)	65,100 ²
Guadalupe River at Saltwater Barrier and Colorado River below Garwood ⁴ (S-15Eb)	132,000 ³

¹ Total firm yield of Cibolo Reservoir with selected pipeline(s) from import optimization analyses.
² Importing water via 60-inch pipeline from Guadalupe River at the Saltwater Barrier.
³ Importing water via two shared 96-inch pipelines from the Colorado River below Garwood to Sandy Creek, a shared 84-inch pipeline from Lake Texana to McFaddin, and an 84-inch pipeline from the Guadalupe River at the Saltwater Barrier.
⁴ Colorado River near Columbus unappropriated water availability presented in this analysis not subject to run-of-the-river environmental criteria.

alternative for the City of Corpus Christi.⁶⁸ Information from the referenced report relevant to Alternative S-15E is summarized in the following discussion. The project area for Alternative S-15E includes Wharton, Jackson, Victoria, Goliad, Dewitt, Karnes, and Wilson Counties. The project area in Wharton, Jackson, and Victoria Counties lies within the Gulf Prairies and Marshes Vegetational Region.⁶⁹ The Gulf Prairies and Marshes Vegetational Area corresponds with Omernik's⁷⁰ Western Gulf Coastal Plain Ecoregion and Blair's⁷¹ Texan Biotic Province. In Goliad County, the proposed pipeline passes through the southernmost extent of the Post Oak Savannah Vegetational Area. The Post Oak Savannah Vegetational Area in Goliad County also lies within Blair's Texan Province. The Texan Biotic Province is a broad, ecologically transitional region (ecotone) between the Tamaulipan Province to the west and the Austroriparian Province to the

⁶⁸ HDR. 1995. Trans-Texas Water Program, Corpus Christi Service Area, Phase II Interim Report, Lavaca-Navidad River Authority.

⁶⁹ Gould, F.W. 1962. Texas plants--A checklist and ecological summary. Texas Agricultural Experiment Station. MP-585.

⁷⁰ Omernik, James M. 1986. Ecoregions of the Conterminous United States. Annals of the Association of American Geographers, 77(1):pp. 118-125.

⁷¹ Blair, W.F. 1950. The Biotic Provinces of Texas. The Texas Journal of Science, 1:93-117.

east. Because of its ecotonal nature, the Texan Province supports a mixture of plant and animal species characteristic of the Tamaulipan and Austroriparian Provinces. Rivers and associated riparian strips coursing through the Texan Province provide valuable habitat as well as corridors for migration. The project area in Dewitt, Karnes and Wilson Counties roughly follows the northeastern boundary of the South Texas Plains. The South Texas Plains Vegetational Area corresponds to Omernik's⁷² Southern Texas Plains Ecoregion and Blair's⁷³ Tamaulipan Biotic Province.

The Gulf Prairies and Marshes Vegetational Area is a level, slowly drained plain lower than 150 ft-MSL with numerous sluggish rivers, creeks, bayous, and sloughs. It is characterized by grasslands that support cattle ranching and farming. Woodlands tend to be concentrated near rivers, swamps, and freshwater marshes making them relatively uncommon and important habitat. Rainfall is higher along this coastal prairie compared to the South Texas Plain, and increases as one moves to the northeast. For example, mean precipitation for Wharton and Jackson Counties averages about 41 inches annually, whereas Wilson County on the South Texas Plain averages only 29.4 inches annually.⁷⁴

The climax vegetation of the Gulf Prairies is considered to be tall grass prairie or post oak savannah. However, grazing practices and fire suppression have resulted in much of the area being invaded by trees and brush. Common species of the brushlands include mesquite (*Prosopis glandulosa*), oaks (especially live oak, *Quercus virginiana*), prickly pear cactus (*Opuntia spp.*), and several species of acacia. Prairie communities are dominated by species such as big bluestem (*Andropogon gerardi*), seacoast bluestem (*Schizachyrium scoparium var. littoralis*), Indian grass (*Sorghastrum avenaceum*), and gulf muhly (*Muhlenbergia capillaris*). Post oak savannah is generally dominated by little bluestem (*S. scoparium var. frequens*), Indian grass switchgrass (*Panicum virgatum*), and wintergrass (*Stipa leucotricha*), in addition to post oak (*Q. stellata*) and blackjack oak (*Q. marilandica*).

⁷² Omernik, James M. 1986. Op. Cit.

⁷³ Blair, W.F. 1950. Op. Cit.

⁷⁴ Griffiths, J. and J. Bryan. 1987. The Climates of Texas Counties. Natural Fibers Information Center, The University of Texas in cooperation with Office of the State Climatologist, Texas A&M University.

The South Texas Plains are also termed the Rio Grande Plains or Tamaulipan Brushlands.⁷⁵ The topography is level to rolling, and the land is dissected by arroyos or by streams flowing into the Rio Grande and the Gulf of Mexico. It is characterized by open prairies and a growth of mesquite (*P. glandulosa*), grangeno (*Celtis pallida*), cacti, clepe (*Ziziphus obtusifolia*), coyotillo (*Karwinskia Humboldtiana*), guayacan (*Porlieria angustifolia*), white brush (*Aloysia gratissima*), brasil (*Condalia Hookeri*), bisbirinda (*Castela texana*), cenizo (*Leucophyllum spp.*), huisache (*Acacia Farnesiana*), catclaw (*A. greggii*), black brush (*A. rigidula*), guajillo (*A. Berlandieri*), and other small trees and shrubs which are found in varying degrees of abundance and composition⁷⁶. Historically, the area was grassland or savanna type climax vegetation, however, long-continued heavy grazing and other factors have resulted in a general change to a cover of shrubs and small trees. Among the several species of shrubs and trees that have made dramatic increases are mesquite, live oak, post oak, and *Acacia spp.*⁷⁷ Blair described the Tamaulipan province of Texas as being characterized by predominantly thorny brush vegetation.⁷⁸ This brushland stretches from the Balcones fault line southward into Mexico. A few species of plants account for the bulk of the brush vegetation and give it a characteristic aspect throughout the Tamaulipan Biotic Province of Texas. The most important of these include: mesquite, lignum vitae (*Porlieria angustifolia*), cenizo (*L. texanum*), white brush (*A. gratissima*), prickly pear (*O. lindheimeri*), tasajillo (*O. leptocaulis*), *Condalia sp.*, and *Castela sp.* The brush on sandy soils differs in species and aspect from that on clay soils. Mesquite, in an open stand and mixed with various grasses, is characteristic of sandy areas. Clay soils usually have all of the species listed above, including mesquite. Although rangeland predominates throughout the South Texas Plains/Tamaulipan Brushland, land use also includes significant acreages in croplands.

The Post Oak Savannah Area⁷⁹ lies immediately west of the primary forest region of Texas. Some authorities consider this plant association as part of the oak-hickory formation. Based on the fact that the typical understory vegetation is tall grass, others classify the area as

⁷⁵ Correll, D. S. and M. C. Johnston. 1979. Manual of the Vascular Plants of Texas. The University of Texas at Dallas.

⁷⁶ Ibid.

⁷⁷ Gould, F. W. 1975. The grasses of Texas. Texas A&M University Press.

⁷⁸ Blair, F.W. 1950. Op. Cit.

⁷⁹ Correl, D.S. and M.C. Johnston. 1979. Op. Cit.

part of the true prairie association of the grassland formation. There is evidence that the brush and tree densities have increased tremendously from the virgin condition. Topography of the Post Oak Savannah is gently rolling to hilly. Rainfall averages 35 to 45 inches annually. Soils on the uplands are light-colored, acid sandy loams or sands. Bottomland soils are light-brown to dark-gray and acid, ranging in texture from sandy loams to clays. Most of the Post Oak Savannah is in native or improved pastures although small farms are common. Climax grasses include little bluestem, Indian grass, switchgrass, purpletop (*Tridens flavus*), silver bluestem (*Bothriochloa saccharoides*), Texas wintergrass, and *Chasmanthium sessiliflorum*. The overstory is primarily post oak and blackjack oak (*Q. marilandica*). Many other brush and weedy species also are common. Some invading plants are red lovegrass, broomsedge (*A. virginicus*), splitbeard bluestem (*A. ternarius*), yankeeweed, bullnettle (*Cnidoscolus texanus*), greenbrier, yaupon (*Ilex vomitoria*), smutgrass, and western ragweed.

Alternative S-15E includes pipelines between the Colorado River and Sandy Creek, between Lake Texana and the town of McFaddin, and between the Saltwater Barrier and the proposed Cibolo Reservoir. The Texas Natural Heritage program does not report any site locations for endangered or threatened species along the proposed pipeline routes. Protected Endangered and Threatened Species possibly occurring in Dewitt, Goliad, Jackson, Karnes, Victoria, and Wilson Counties are noted in Tables 14, 20, 24, 26, 44, and 48 of Appendix B (Volume 2).

The 16.3 mile long pipeline between the Colorado River and Sandy Creek will require a construction ROW 140 feet wide and affect 277 acres. Approximately 24 acres (8.8 percent) of the affected area is wooded. The remaining 253 acres (91.2 percent) is agricultural land used for crops or as pasture. A 40 foot wide ROW maintained free of woody vegetation for the life of the project would affect a total of 79 acres. Most of the affected land could be returned to agricultural uses following construction. Pipeline construction would include some impact to woods, however, such impacts could be reduced from the figures given above by judicious pipeline alignment.

The pipelines between Lake Texana and McFaddin and between the Saltwater Barrier and Cibolo Reservoir are about 121 miles in total length. Construction would affect approximately 2060 acres including 33 acres (1.6%) of wood, 31 acres (1.5%) of park, 602 acres (29.2%) of

brush, 91 acres of (4.4%) shrub, 472 acres (22.9%) of grassland/pasture, 737 (35.8%) acres of crop, 10 acres (0.5%) of swamp, 6 acres (0.3%) of marsh, and 78 acres (3.8%) that have been developed for residential, commercial, and industrial uses. A 40 foot ROW maintained free of woody vegetation for the life of the project would affect about 587 acres. However, vegetation in cropland and pastures, and animal species associated with these habitats, would be expected to return to near original condition following seeding.

Several small creeks would be crossed by the proposed pipeline between the Colorado River and Sandy Creek including West Mustang Creek, Porter's Creek, and Lookout Creek. The proposed pipeline route between Lake Texana and McFaddin crosses Garcitas Creek, Placedo Creek, the Guadalupe River, Ecleto Creek, and several other small creeks. Additionally, because woodlands in this area are often limited to the riparian strips associated with creeks and rivers, these riparian woodlands constitute an important habitat for many plant and animal species. A detailed environmental assessment to include wetlands delineation, an endangered species survey, habitat mapping and an inventory of the vegetation affected along the pipeline ROW would be needed prior to implementing the project. With respect to pipeline installation, significant impacts to environmental resources can often be avoided by selection of the pipeline easement.

Intakes for implementing Alternative S15-E would be located on the Guadalupe and Colorado Rivers. The Colorado River flows from west to southeast through Texas from the Llano Estacado in New Mexico, across the Western High Plains Ecoregion through the Central Plains and across the Central Texas Plateau before crossing the Balcones Escarpment and flowing through the Blackland Prairies and East Central Plains to the Western Gulf Coastal Plains. In Wharton County, the Colorado River is a large, low gradient stream generally exhibiting fine-grained sediments in extensive sandy braided reaches and occasional cobble and gravel riffles. As is commonly the case in coastal plain reaches, pool-riffle sequences are poorly developed. Low head dams impound two significant reaches of the river below Wharton. In addition to the numerous impoundments on the upper river and on major and minor tributaries, the Highland Lakes (large mainstream reservoirs constructed on the Edwards Plateau) are operated by the Lower Colorado River Authority to provide hydropower, flood control, and water storage in the lower Colorado River Basin. Operation of these reservoirs, particularly winter storage and summer releases of water for rice irrigation in Colorado, Wharton and Matagorda Counties, has

substantially altered the annual hydrography of the lower river (below Austin) from its historical condition.⁸⁰

Below Bay City, the Colorado River is tidally influenced (Segment 1401), and its aquatic community is characterized by more marine species. The river mouth has recently been relocated by the U.S. Army corps of Engineers (USCE) so that it no longer discharges directly into the Gulf of Mexico, but into the eastern arm of Matagorda Bay, as it did prior to its rapid delta propagation some 60 years ago. This action is expected to increase Colorado River inflows to Matagorda Bay by about 30% (from an average of 1.2 million to about 1.7 million acre feet per year), but hydrologic and modeling studies are still in progress.⁸¹

Potential effects on the Colorado River from operation of this alternative include entrainment of Colorado River flora and fauna, and reduced streamflows below the diversion. Although the numerous long-term agricultural diversions in place on this reach suggest that the present riverine community is tolerant of the effects of entrainment, it should be minimized by selection of an intake location that does not attract fish, and by use of appropriate screening technology to reduce potential losses to aquatic populations. The blue sucker (*Cycoreptus elongatus*) and the Guadalupe bass (*Micropterus treculi*) occur in the reach of the Colorado River where the proposed intake would be constructed. The blue sucker is listed by Texas Parks and Wildlife as threatened and by U.S. Fish and Wildlife Service as a Candidate 2 species. The Guadalupe bass is listed by U.S. Fish and Wildlife Service as a Candidate 2 species. A survey of the river in the area of the diversion should be conducted to identify critical habitats (e.g. nursery habitat) for aquatic species that could be avoided.

Sandy Creek, which already receives rice irrigation return flows originating from the Colorado River, will experience substantial increases in flow if Alternative S-15E is implemented. Changes in the flow of Sandy Creek resulting from this alternative are unlikely to produce adverse impacts to Sandy Creek or its tributaries such as Goldenrod Creek.

American Bald Eagles formerly nesting on Sandy Creek have relocated to Lake Texana, and no other listed endangered, threatened, or unlisted species of concern, have been reported to

⁸⁰ Mosier, D.T. and R.T. Ray. 1992. Instream Flows for the Lower Colorado River. Lower Colorado River Authority, Austin, Texas.

⁸¹ TWDB. 1990. Unpublished data, Bay and Estuaries Study Program, Texas Water Development Board, Austin, Texas.

presently occur there.⁸² Also, on Goldenrod Creek, about three quarters of a mile upstream from its confluence with Sandy Creek, there are woods of the coastal live oak - post oak series and water oak - coastal live oak series.⁸³ The discharge of Colorado River water into Sandy Creek proposed under this alternative is unlikely to have an impact on these communities or the riparian woodlands along Sandy Creek.

Alternative S-15E involves transferring Colorado River water through Lake Texana. Colorado River irrigation water is currently transferred to Sandy Creek and Lake Texana. Thus, the additional water due to this alternative would not be expected to produce changes in the ecology of Lake Texana or the rivers and bays downstream. However, possible impacts due to the interbasin transfer of organisms is of some concern and is under investigation.⁸⁴ The possibility of transferring organisms from the Colorado and Lavaca-Navidad River Basins to Cibolo Reservoir could raise concerns and will need to be addressed.

Potential changes in streamflow resulting from the implementation of the largest scale importation source scenario (S-15Eb) associated with the proposed Cibolo Reservoir were evaluated for Cibolo Creek below Cibolo Reservoir and the Saltwater Barrier. Monthly median streamflows and annual streamflows averaged by decile at each of these locations with and without the project are compared in Figure 3.47-2.

Modeling the operations of Cibolo Reservoir, including the interbasin transfers, indicated that annual median flow in Cibolo Creek would be reduced from 50,743 acft/yr to 25,049 acft/yr (50.6 percent). Decreases in monthly median flows would range from 63.4 percent to 8.9 percent. In terms of flows in Cibolo Creek at Falls City, the most significant effects would be a reduction in high flows with a concomitant reduction in flow variability. Plant and animal species favoring reduced, consistent flow can be expected to increase relative to those favoring more variable flows.

Modeling flows for the Guadalupe River below the Saltwater Barrier indicated that annual flow would be reduced from 1.07 million acft/yr to 0.99 million acft/yr (6.9 percent). Decreases

⁸² TPWD. 1993. Texas Parks and Wildlife Department National Heritage Program special animal files; and Mark Mitchell, pers comm.

⁸³ Ibid.

⁸⁴ U.S. Army Corps of Engineers, Fort Worth District. 1995. Technical Memorandum. Potential Aquatic Ecological Effects of Two Proposed Interbasin Water Transfers in the South-Central Study Area.

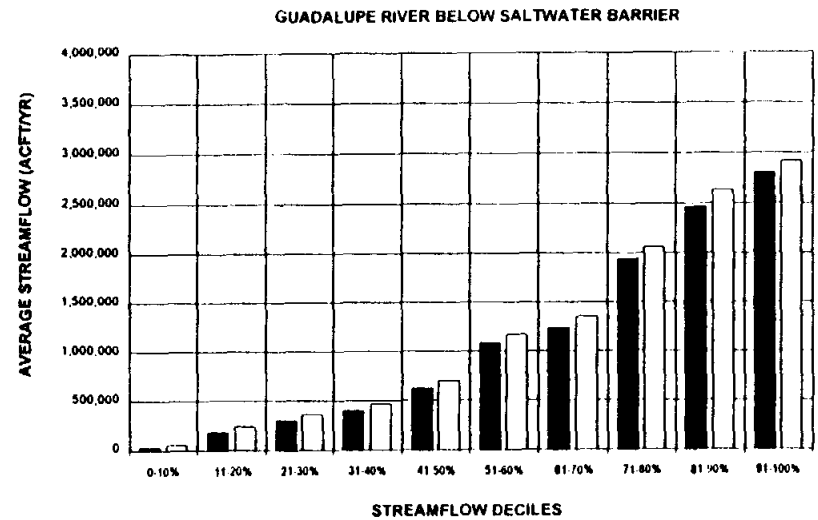
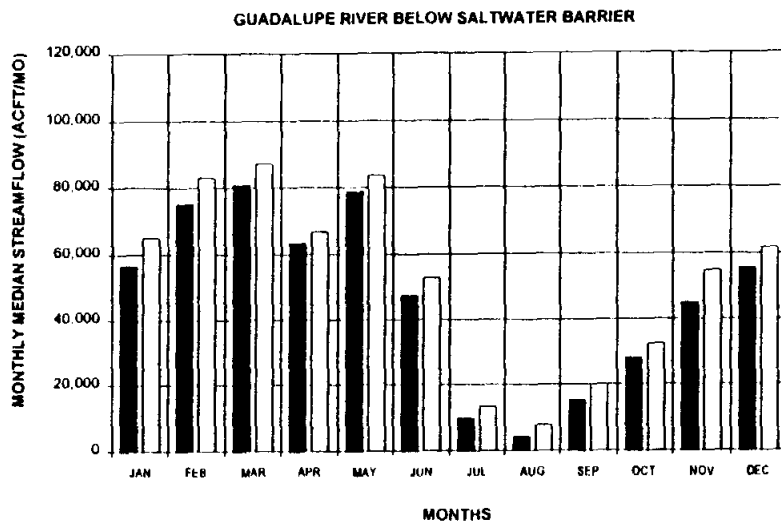
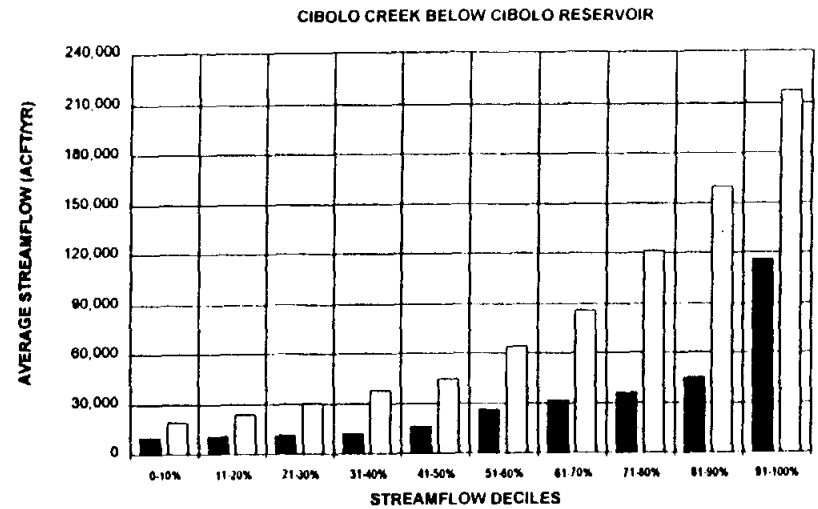
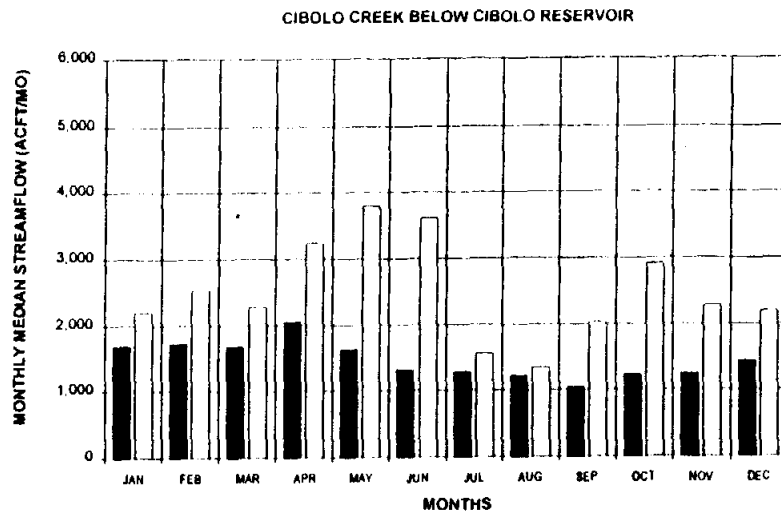

LEGEND:

- WITH PROJECT
- WITHOUT PROJECT

NOTE: STATISTICS BASED ON 1941-65 HISTORICAL PERIOD



HDR Engineering, Inc.

TRANS TEXAS WATER PROGRAM /
WEST CENTRAL STUDY AREA

**CHANGES IN STREAMFLOW
CIBOLO CREEK AND SALTWATER
BARRIER, ALTERNATIVE S-15E**

FIGURE 3.47-2

in monthly median flows would range from 42.4 percent during the month of lowest flow to 5.2 percent in a higher flow month. In terms of medians, flow reductions would be fairly consistent from month to month and maintain a pattern of seasonal variation similar to that without the project. Although the monthly variation pattern would be maintained and the greatest decreases in flow volume would occur in high flow deciles, percent flow reductions would be greatest in low flow deciles. This is because reclaimed water represents a greater proportion of the water diverted during low flows compared with that diverted during higher flows. Detailed environmental studies would be needed to assess actual instream flow needs for the Colorado and Guadalupe Rivers prior to implementation of a project.

Cultural resources protection on public lands in Texas is afforded by the Antiquities Code of Texas (Title 9, Chapter 191, Texas Natural Resource Code of 1977), the National Historic Preservation Act (PL96-515), and the Archaeological and Historic Preservation Act (PL93-291). All areas to be disturbed during construction would first be surveyed by qualified professionals to determine the presence or absence of significant cultural resources.

3.47.4 Water Quality and Treatability

[To be completed in subsequent phases of the study.]

3.47.5 Engineering and Costing

For this alternative (S-15E), water potentially available for diversion from the Saltwater Barrier would be pumped at non-uniform rates to Cibolo Reservoir, which would serve as a storage and balancing reservoir. Water potentially available for diversion from the Colorado River would be pumped at non-uniform rates to Sandy Creek, flow into Lake Texana, and be pumped at a uniform rate from Lake Texana into the import pipeline from the Saltwater Barrier to Cibolo Reservoir. From Cibolo Reservoir, the firm yield would be pumped at a uniform rate to the proposed South Water Treatment Plant, where it would be treated to drinking water quality prior to delivery. The benefit from these projects would be the addition of a new potable water supply to the San Antonio distribution system and possibly other water supply systems in the surrounding area. The major facilities required to implement these alternatives are:

- Importation Source River Intakes and Pump Stations
- Raw Water Pipelines
- Dam and Reservoir
- Reservoir Intakes and Pump Stations
- Raw Water Pipeline to South Water Treatment Plant
- Raw Water Booster Stations
- South Water Treatment Plant (Level 3; see Section 3.0.2, Volume 2)
- Distribution System Improvements

Optimization analyses were performed to select the appropriate import pipeline size for delivery of water from the Saltwater Barrier to Cibolo Reservoir. Unit costs and incremental unit costs based on the associated additional firm yield were computed for import pipelines ranging in diameter from 24 inches to 120 inches. Unit cost is defined to be the total importation facilities cost for one import pipeline diameter divided by the resultant additional yield, while incremental unit cost is defined to be the incremental importation facilities cost divided by the incremental additional yield obtained by comparison with cost and additional yield for the next smaller diameter. The import pipeline size was generally selected in accordance with the following criteria: 1) Pipeline diameter greater than or equal to that having the least unit cost; and 2) Largest pipeline diameter with a reasonable incremental unit cost.

For each source scenario or alternative, costs for the selected importation facilities were combined with costs for Cibolo Dam and Reservoir (see Section 3.15, Volume 2), other major facilities listed above, and related project costs (land acquisition, mitigation, engineering, etc.) to obtain Total Project Cost. Total Project Cost was then converted to annual debt service (25 year finance period at 8 percent interest) and combined with related operations and maintenance and power costs to obtain Total Annual Cost. Cost estimates for each importation source scenario are summarized in Table 3.47-2 and discussed in the following subsections.

Alternative S-15Ea: Import from Saltwater Barrier

Cibolo Reservoir operated in conjunction with available water imported from the Saltwater Barrier could provide a firm yield of about 65,100 acft/yr at an annual cost of \$952/acft. This firm yield and annual cost are based on a 60-inch diameter import pipeline from the Saltwater Barrier and a 60-inch transmission pipeline from Cibolo Reservoir to the proposed South Water

Table 3.47-2		
Cost Estimates for Cibolo Reservoir with Imported Water		
From the Saltwater Barrier and Colorado River (S-15E)		
(Mid 1994 Prices)		
Item	Import Saltwater Barrier Water (S-15Ea)	Import Saltwater Barrier and Colorado¹ River Water (S-15Eb)
Capital Costs		
Dam and Reservoir	\$114,430,000	\$114,430,000
Transmission and Pumping	116,250,000	255,810,000
Treatment Plant	27,000,000	48,000,000
Delivery System	<u>50,040,000</u>	<u>83,360,000</u>
Total Capital Cost	\$307,720,000	\$501,600,000
Engineering, Contingencies, and Legal Costs	98,040,000	156,320,000
Land Acquisition	34,700,000	35,070,000
Environmental Studies and Mitigation	29,600,000	30,760,000
Interest During Construction	<u>28,200,000</u>	<u>37,380,000</u>
Total Project Cost	\$498,260,000	\$761,130,000
Annual Costs		
Annual Debt Service	\$46,680,000	\$71,320,000
Annual Operation and Maintenance	7,490,000	13,130,000
Annual Power Cost	<u>7,810,000</u>	<u>18,020,000</u>
Total Annual Cost	\$61,980,000	\$102,470,000
Available Project Yield (acft/yr)	65,100	132,000
Annual Cost of Water (\$/acft/yr)	\$952	\$776
¹ Available water from the Colorado River near Garwood estimated without application of environmental criteria for run-of-the-river diversions.		

Treatment Plant. The information used to select the 60-inch diameter import pipeline from the Saltwater Barrier to Cibolo Reservoir is illustrated in Figure 3.47-3. Key observations upon consideration of Figure 3.47-3 are summarized as follows:

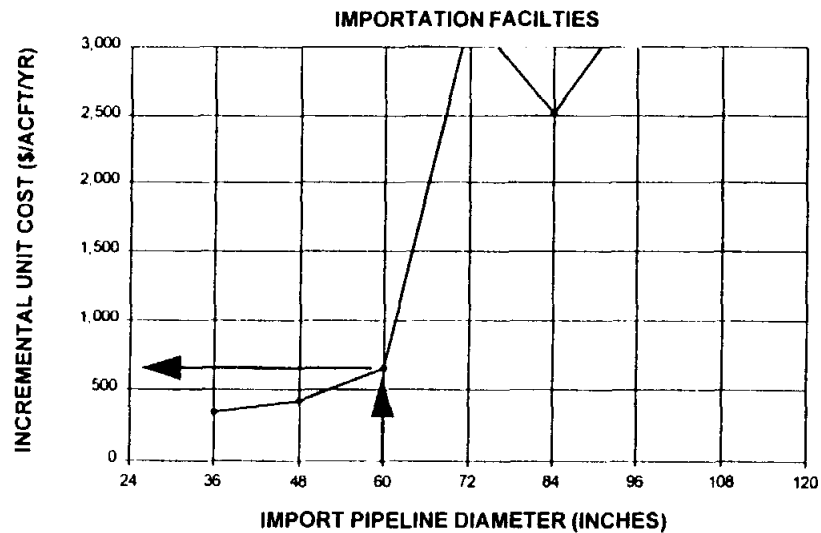
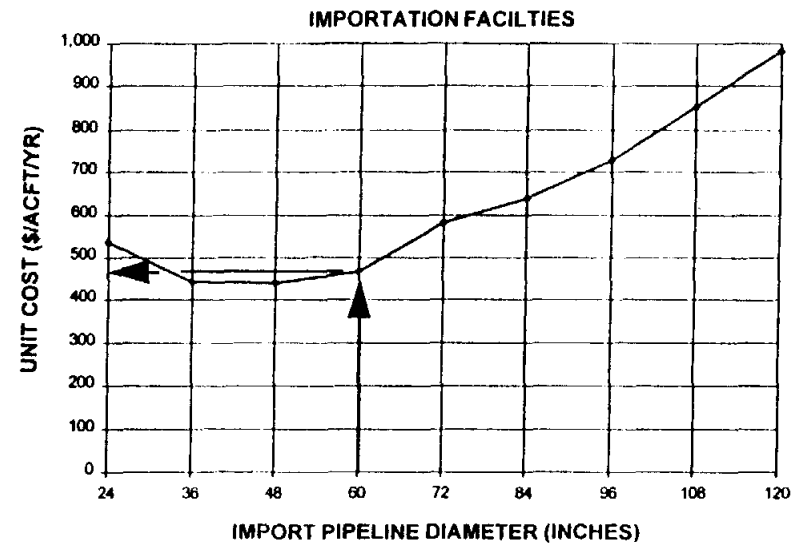
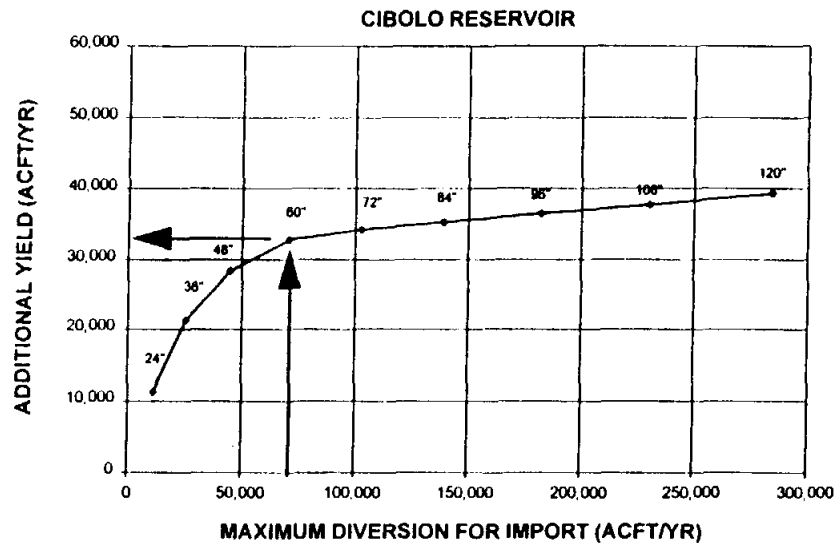

ASSUMPTIONS:

1. SPRING FLOWS RESULTING FROM FIXED EDWARDS AQUIFER PUMPAGE OF 400,000 ACFT/YR.
2. HYDROPOWER WATER RIGHTS FULLY SUBORDINATED TO CANYON LAKE.
3. UNCOMMITTED FIRM YIELD OF CANYON LAKE DIVERTED NEAR NEW BRAUNFELS.
4. RETURN FLOWS SET AT RATES OBSERVED IN 1988.
5. IMPORTS INCLUDE SAWS RECLAIMED WATER AND UNAPPROPRIATED STREAMFLOW SUBJECT TO ORIGINAL TRANS-TEXAS ENVIRONMENTAL CRITERIA.

TRANS TEXAS WATER PROGRAM /
WEST CENTRAL STUDY AREA



HDR Engineering, Inc.

**OPTIMIZATION SUMMARY
SALT WATER BARRIER ONLY
ALTERNATIVE S-15E**

FIGURE 3.47-3

1. With a maximum diversion rate of about 71,000 acft/yr (100 cfs), a 60-inch diameter import pipeline could enhance the firm yield of Cibolo Reservoir by about 32,800 acft/yr. Considering unappropriated streamflow only, little additional yield could be obtained with larger diameter import pipelines. Importation of water potentially available for purchase under existing rights in the lower Guadalupe-San Antonio River Basin could increase the yield for this alternative.
2. On the sole basis of unit cost for importation facilities, a 48-inch diameter import pipeline (\$440/acft/yr) could be selected rather than a 60-inch diameter import pipeline (\$468/acft/yr).
3. Considering incremental unit cost for importation facilities, it is probable that the import pipeline would be "up-sized" to a 60-inch diameter as additional yield relative to the next smaller diameter costs \$650/acft/yr which is still a reasonable unit cost of water. "Up-sizing" to a 72-inch diameter, however, would not be recommended as the additional yield costs more than \$3000/acft/yr.

Alternative S-15Eb: Import from Saltwater Barrier and Colorado River

Cibolo Reservoir operated in conjunction with available water imported from the Saltwater Barrier and the Colorado River below Garwood could provide a firm yield of about 132,000 acft/yr at an annual cost of \$777/acft. This firm yield and annual cost are based on an 84-inch diameter import pipeline from the Saltwater Barrier, an 84-inch import pipeline from Lake Texana (joining the Saltwater Barrier import pipeline), two 96-inch diameter import pipelines from the Colorado River to Sandy Creek, and an 84-inch transmission pipeline from Cibolo Reservoir to the proposed South Water Treatment Plant. The segments of the import pipelines from the Colorado River to Sandy Creek and from Lake Texana to McFaddin in this alternative were assumed to be "shared" facilities with the City of Corpus Christi and the Lavaca-Navidad River Authority as they have developed long-term plans which include import pipelines along these alignments.⁸⁵ The costs associated with the parallel 96-inch diameter import pipelines from the Colorado River to Sandy Creek were prorated based on required capacity for the Corpus Christi (20 percent) and West Central (80 percent) Service Areas. Similarly, the costs associated with the 84-inch transmission pipeline from Lake Texana to McFaddin were prorated based on required capacity for the Corpus Christi (50 percent) and West Central (50 percent) Service Areas. It is noted that actual additional yield due to importation of unappropriated streamflow from the Colorado River could be reduced significantly by the application of environmental

⁸⁵ HDR Engineering, Inc., "Trans-Texas Water Program, Corpus Christi Service Area, Phase II Interim Report," Lavaca-Navidad River Authority, September, 1995.

criteria for instream flows or for freshwater inflows to bays and estuaries. Importation of water potentially available under existing rights in the Colorado Basin, however, might increase water availability.

3.47.6 Implementation Issues (S-15E)

An institutional arrangement is needed to implement projects including financing on a regional basis.

Cibolo Reservoir and Channel Dam

1. It will be necessary to obtain these permits:
 - a. TNRCC Water Right and Storage permits.
 - b. U.S. Army Corps of Engineers Sections 10 and 404 dredge and fill permits for Cibolo Reservoir, channel dam, and intake structures.
 - c. GLO Sand and Gravel Removal permits.
 - d. GLO Easement for use of state-owned land.
 - e. Coastal Coordination Council review.
 - f. TPWD Sand, Gravel, and Marl permit.
2. Permitting, at a minimum, will require these studies:
 - a. Bay and estuary inflow impact.
 - b. Habitat mitigation plan.
 - c. Environmental studies.
 - d. Cultural resource studies.
3. Land will need to be acquired through either negotiations or condemnation.
4. Relocations for the reservoir include:
 - a. Highways and railroads.
 - b. Other utilities.

Requirements Specific to Diversion of Water from Saltwater Barrier

1. Necessary Permits:
 - a. TNRCC Permit to divert unappropriated water.
 - b. TNRCC Bed and Banks Permit for use of affected reaches of San Antonio River to deliver private water from SAWS return flows.
 - c. Possibly TNRCC Interbasin Transfer Approval.
 - d. GBRA approval for diversion facilities.
2. Permitting will require these studies:
 - a. Instream flow issues and impacts.
 - b. Environmental studies.
 - c. Bay and Estuary inflow issues.
3. Water demand reduction programs by SAWS may reduce the quantity of future return flows.
4. Use of return flows must be negotiated with SAWS. Use arrangements should consider drought contingency planning that may result in a reduction of return flows by SAWS.

Requirements Specific to Diversion of Water from Colorado River

1. Necessary Permits:
 - a. TNRCC permit to divert unappropriated water.
 - b. TNRCC Interbasin Transfer Approval.
2. Permitting will required these studies:
 - a. Instream flow issues and impact.
 - b. Environmental studies.
 - c. Bay and Estuary inflow issues.

Requirements Specific to Pipelines

1. Necessary permits:
 - a. U.S. Army Corps of Engineers Sections 10 and 404 dredge and fill permits for stream crossings.
 - b. GLO Sand and Gravel Removal permits.
 - c. Coastal Coordination Council review.
 - d. TPWD Sand, Gravel and Marl permit.
2. Right-of-way and easement acquisition.
3. Crossings:
 - a. Highways and railroads.
 - b. Creeks and rivers.
 - c. Other utilities.

Requirements Specific to Treatment and Distribution

1. Detailed study needed of the cost of pumping and transmission pipeline improvements necessary to effectively integrate the new supply into the San Antonio water supply system.
2. Study needed of cost to convey and distribute water to other area water utilities.

3.48 Upper Cibolo Creek Reservoir Cost Analyses (S-17)

3.48.1 Description of Alternative

The Upper Cibolo Creek Reservoir near Bracken, Texas has been proposed⁸⁶ as a possible means of sustaining both Comal springflow and Edwards Aquifer pumpage during drought conditions. The reservoir would serve as a storage facility for runoff from its 260 square mile watershed and potentially for water imported from other river basins. Potential sources of water for importation could include Canyon Lake and the Blanco River. Under one operational concept,⁸⁷ water would be released from storage into the Edwards Aquifer during times of drought with the intent of maintaining desired flows at Comal Springs so that aquifer pumpage curtailment could be minimized. It is important to note, however, that no conclusive studies have been performed to date which confirm an hydrogeologic connection between the reservoir and Comal Springs.

The Upper Cibolo Creek dam site is located within the Edwards Aquifer recharge zone on Cibolo Creek approximately three miles north of Bracken, Texas (see Figure 3.48-1). The proposed dam centerline crosses the creek in an east-west direction and connects Comal County to the east with Bexar County to the west (see Figure 3.48-2). The elevation of the creek bed at the proposed dam site is 805 ft-MSL. The proposed reservoir impounded by the dam would store approximately 150,000 acft below elevation 954 ft-MSL and extend approximately 11 river miles upstream. At this elevation, the surface area of the reservoir would be about 3,400 acres.

The conceptual dam design consists of a 3,800-foot long earth and rock fill embankment with a crest elevation of 978 ft-MSL (maximum dam height of 173 feet). The conceptual spillway system consists of a 300-foot wide concrete ogee principal spillway with a crest elevation of 954 ft-MSL (maximum normal pool level) and a 1,500-foot wide earth/rock cut auxiliary spillway with a crest elevation of 965 ft-MSL located in a natural saddle approximately 500 feet northeast of the dam. The principal spillway is sized to pass the 100-year flood event without engaging the auxiliary spillway. The spillway system and dam crest elevation of 978 ft-MSL facilitate safe passage of the probable maximum flood.

⁸⁶ Postel, A.E., "The Value of Aquifer Water and the Cost of Its Supplementation to Supply the San Antonio Water System and Maintain Springflows," April, 1994.

⁸⁷ Ibid.

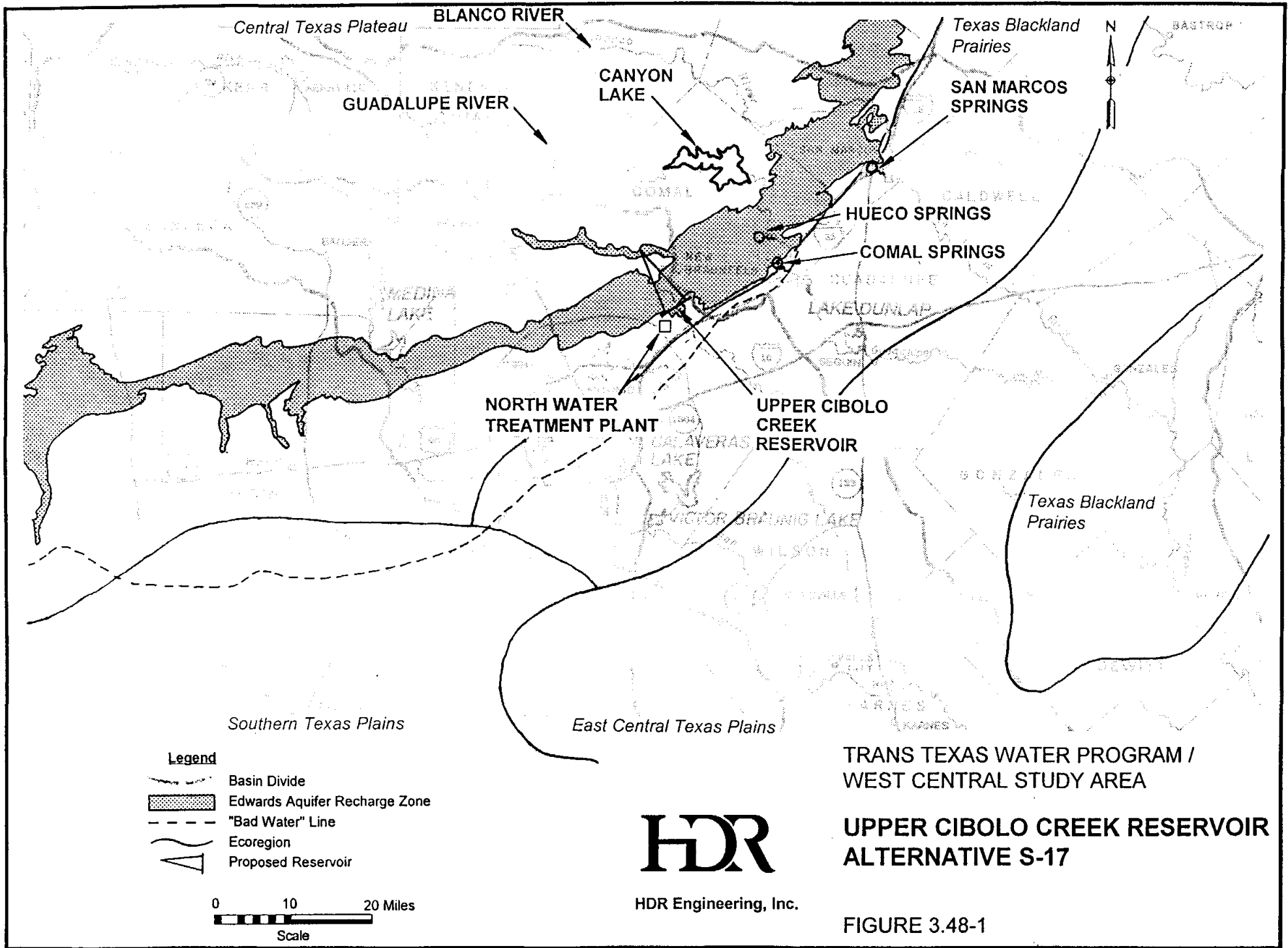

FIGURE 3.48-2

Upper Cibolo Creek Reservoir

Alternative S-17

z-fold enlargement

The dam and a majority of the proposed reservoir would be located atop the Kainer Formation of the Edwards Aquifer. The various geologic units of the Kainer Formation exhibit extensive fracturing, jointing, bedding planes and solution features, all of which contribute to the effective recharge of flow in Cibolo Creek to the Edwards Aquifer downstream of Bat Cave Fault. The dam foundation notwithstanding, sealing the Kainer Formation in the reservoir to prevent uncontrolled recharge presents major investigation, design, and construction challenges.

3.48.2 Available Yield

If Upper Cibolo Creek Reservoir were operated with the primary objective of sustaining flows from Comal Springs, its available yield would be realized in the form of sustained Edwards Aquifer pumpage during drought periods. If controlled recharge from the reservoir could, in fact, maintain discharge from Comal Springs at a rate in excess of a specified jeopardy level, curtailment of aquifer pumpage under a drought management plan might be minimized, particularly in Uvalde, Medina, and Bexar Counties. Significant hydrogeological questions exist, however, as to how much of the water recharged at the reservoir would bypass Comal Springs and flow towards Hueco and San Marcos Springs (see Figure 3.48-1). Furthermore, it is possible that the hydraulic gradient of the aquifer could be reversed during drought causing water recharged at the reservoir to flow in the direction of concentrated municipal and industrial pumpage in the San Antonio metropolitan area. Long-term average recharge which occurs naturally along Cibolo Creek above the proposed dam site would be reduced significantly by sealing of the Kainer formation to impound the reservoir. The ability of current hydrogeologic computer models to simulate the complex physical processes involved sufficiently accurately to address these concerns is also in question at this time.

In order to provide a minimum, conventional estimate of the available yield of Upper Cibolo Creek Reservoir, the firm yield of the proposed 150,000 acft reservoir was computed utilizing only runoff originating in the Cibolo Creek watershed. Basic assumptions included the application of Trans-Texas Environmental Criteria for New Reservoirs (see Appendix C, Volume 2), springflows resulting from a fixed Edwards Aquifer pumpage rate of 400,000 acft/yr, return flows typical of calendar year 1988, and full subordination of Guadalupe River hydropower water

rights to Canyon Lake. The Guadalupe - San Antonio River Basin Model⁸⁸ (GSA Model) was used to estimate monthly quantities of total streamflow and unappropriated streamflow potentially available at the reservoir site. For modeling purposes, streamflows for Cibolo Creek at Selma (ID #1850) were assumed to be representative of inflows to Upper Cibolo Creek Reservoir. The firm yield was computed using an original model (RESSIM) specifically written to simulate reservoir operations subject to the Trans-Texas Environmental Criteria using water availability estimates from the GSA Model. Assuming a drought contingency trigger at 60 percent of capacity and uniform monthly diversions from the reservoir, the firm yield would be about 8,700 acft/yr.

It is possible that the conventional firm yield of Upper Cibolo Creek Reservoir could be increased with importation of water potentially available from the Guadalupe River or Canyon Lake. Pertinent water supply alternatives which could provide for such importation are described in Sections 3.43, 3.44, and 3.45 and in Appendix J of this volume of the Phase I Interim Report. There is insufficient technical information available at this time, however, to speculate as to additional quantities of water which could be pumped from the Edwards Aquifer if Upper Cibolo Creek Reservoir were operated solely to sustain Comal Springs during drought rather than operated as a traditional surface water supply reservoir. The proximity of the Upper Cibolo Creek Reservoir site to one proposed site for a new North Water Treatment Plant (see Figure 3.48-1) suggests the possibility of multi-objective use of the reservoir for conventional surface water supply, terminal/balancing storage for imported water, recharge enhancement, and/or maintenance of springflows. Such potential combinations of alternatives and multi-objective use(s) of the reservoir, however, are beyond the scope of Phase I of the Trans-Texas Water Program.

3.48.3 Environmental Issues

Upper Cibolo Creek Reservoir is a proposed impoundment on Cibolo Creek which follows the county line between Bexar County to the southwest and Comal County to the northeast. Although the site is only 2.5 miles from Bracken, a suburb of San Antonio, the land is predominately oak-Ashe juniper wood and is used primarily for cattle ranching. The proposed

⁸⁸ HDR Engineering, Inc., "Guadalupe - San Antonio River Basin Recharge Enhancement Study," Edwards Underground Water District, September, 1993.

reservoir would inundate approximately 3,400 acres. The reservoir site has been previously considered as a site for a smaller recharge reservoir (Cibolo Dam No. 1)⁸⁹ and the biogeography and geology of the area have been described previously in the context of the Trans-Texas Water Program (Section 3.9, Volume 2).

Bexar County is largely urban and serves as a wholesale, retail and distribution center for a wide area. San Antonio is the tenth largest city in the nation and third largest in Texas. Tourism and federal military expenditures represent a significant contribution to the economy of the area. The population density of Comal County is about 10 percent that of Bexar County. The climate of this subtropical region is characterized by hot, humid summers and variable winters. The number of days with temperatures over 90° F averages over 110 per year and the growing season averages over 260 days. Thunderstorms, peaking in late spring and early fall, account for much of the rainfall which ranges from 29 to 34 inches in the two-county area.

The northern half of Bexar County and all of Comal County are within the Edwards Plateau and Blackland Prairies Vegetational Areas. The southern half of Bexar County is within the South Texas Plains.⁹⁰ The proposed Upper Cibolo Creek Reservoir is located within the Edwards Plateau Vegetational Area, near its southeastern margin which contacts the Blackland Prairie. Habitat types reported to occur at the proposed reservoir site include live oak (*Quercus virginiana*) - Ashe juniper (*Juniperus ashei*) wood, live oak - Ashe juniper park, and live oak - mesquite (*Prosopis glandulosa*) - Ashe juniper park.⁹¹

The Edwards Plateau comprises about 24,000,000 acres of "Hill Country" in west-central Texas.⁹² The soils are usually thin and underlain by limestone or caliche on the Plateau proper. The Edwards limestones that cap the plateau were formed by the deposition of shells and corals during the early to late Cretaceous Period when central Texas lay under a shallow sea. Recession of the sea and uplift exposed the Edwards limestones about 15,000 years ago. Along the eastern and southern margins of the Edwards Plateau, uplift formed the Balcones Escarpment which is cut

⁸⁹ Espey, Huston & Associates, Inc. 1982. Feasibility Study of Recharge Facilities on Cibolo Creek. Draft Document No. 82448.

⁹⁰ Gould, F.W. 1962. Texas Plants--A checklist and ecological summary. Tex. Agr. Exp. Sta. MP-585

⁹¹ McMahan, C.A., R.G. Frye and K.L. Brown. 1984. The Vegetation Types of Texas Including Crop. Wildlife Division, TPWD.

⁹² Correll, D.S and M.C. Johnston. 1979. Manual of the Vascular Plants of Texas. The University of Texas at Dallas. Richardson, Texas.

by spectacular canyons and forms a distinct boundary between the plateau and the adjacent blackland prairies.

The rough, irregular surface of the plateau is well-drained, being dissected by several perennially flowing river systems that have their origin in the large number of springs in this limestone-based region. Because of the many large canyons and rugged terrain, this area is botanically of much interest and has been visited by many botanical collectors. The brush species on the uplands are generally considered to be invaders, however, the steeper canyon slopes have continually supported a dense oak-juniper thicket. Climax vegetation on the plateau is primarily grassland and open savannah. The most important climax grasses of the plateau include switchgrass, several species of bluestems and grammas, Indian grass, Canada wild-rye, curly mesquite and buffalo grass.

Land uses, habitat types and values, and wetland occurrences within the study area were identified and evaluated using available literature and a variety of other sources, including the Texas Natural Resources Information System's aerial photography and map database; Texas Highway Department aerial photography; Texas Parks and Wildlife Department (TPWD), Resource Protection Division's data and mapping files for endangered, protected and sensitive resources; U.S. Fish and Wildlife Service (USFWS) National Wetland Inventory (NWI) maps; information available from the Edwards Aquifer Research and Data Center; USGS library resources; Texas Natural Resource Conservation Commission (TNRCC) publications and library; consultant reports; and the general biological literature, particularly descriptions of the habitat requirements of species listed as Endangered or Threatened by either the U.S. Department of the Interior or the State of Texas. This data base, including archaeological sites, significant environmental features, state natural areas, protected species, and potential wetland areas, were mapped on USGS 7.5 minute quadrangles maintained at Paul Price Associates, Inc. Field surveys of selected areas of the proposed Cibolo Reservoir were conducted in August, 1994 and September, 1995, including the proposed dam site, Devine Spring and Clear Spring on West Fork Creek, and the upper part of the project area where it crosses FM 1863.

The project area can be characterized as live oak wood and park, or live oak - Ashe juniper wood and park depending on location. Concentrations of cedar elm, Texas oak, or persimmon dominate in scattered patches. Below the confluence of West Fork and Cibolo Creek,

the hillsides west of Cibolo Creek, as well as the steeper east bank, have been recently cleared (equipment was on the site) of Ashe juniper, many of which were mature trees. In some areas the live oak woodland with a secondary overstory of Ashe juniper included clumps of large Texas oaks that appear to be remnants of generations of clearing primarily Ashe juniper. Although no species listed by USFWS or TPWD as endangered or threatened were observed during the brief field trips, habitat for several important species may be present in the project site. For example, golden-cheeked warblers nest in oak-Ashe juniper woods. Several sites visited during the recent field survey were selected from aerial photographs based on the possible presence of dense stands of oak-juniper woods. Although clearing the Ashe-juniper in some of the areas visited eliminated potential nesting habitat, relict stands of oak-juniper woods may exist within the project area. Similarly, habitat for the black-capped vireo or other species of concern could be present within the project area. A comprehensive survey of the project area should be conducted for the presence of critical habitat for endangered species. Endangered and Threatened species for Bexar and Comal Counties are listed in Tables 6 and 13 in Appendix B (Volume 2), respectively.

The bed of Cibolo Creek in the project area below the confluence at West Fork was about 100 feet wide, dry, and consisted of large boulders and gravel deposits. A narrow cave opening in the creek bed was explored briefly. The cave was located near the place where Bat Cave Fault crosses Cibolo Creek. The opening was 3 to 6 inches wide and approximately 4 feet long running generally east to west. The floor of a small room, about 10 feet to 12 feet below, was visible from the mouth of the cave. Although the cave was known to local ranchers it was not recorded in the Texas Speleological Survey database.⁹³ The project is in an area of Bexar County considered to have a "good" probability (out of excellent, good, fair, poor, highly improbable) for the discovery of new caves.⁹⁴ There are eight known caves within the reservoir pool. Another six caves near the project descend below the maximum normal reservoir pool elevation of 954 ft-MSL and could be subjected to some flooding. Additionally, Bracken Bat Cave and Natural Bridge Caverns nearby could be affected by the construction and operation of the proposed reservoir.⁹⁵ Although none of the rare cave invertebrates in Bexar County recently petitioned for

⁹³ Dr. William Elliott, 1995, personal communication.

⁹⁴ Veni, G. 1988. *The Caves of Bexar County*. Second Edition. Texas Memorial Museum. Speleological Monographs, 2. The University of Texas at Austin.

⁹⁵ Op. Cit. Espey Huston & Associates, Inc., 1982.

inclusion on the Endangered Species List has been reported to occur on the project site some of the cave invertebrates are known to inhabit caves in the project area. For example, Poison Ivy Pit (located about 1,000 feet from the edge of the proposed normal pool of Upper Cibolo Creek Reservoir) has been reported to contain an isopods (an unidentified species of the family *Trichoniscidae*), spiders (*Eidmannella rostrata*, *Modisimus texanus*), harvestmen (*Leiobumum townsendii*), cave crickets (*Ceuthophilus secretus*), and cave beetles including *Rhadina infernalis*. The mouth of Poison Ivy Pit is located at elevation 995 ft-MSL and the bottom is located at 889 ft-MSL.

Several springs, some of them still flowing, exist within the project area and would be flooded by the proposed reservoir elevation of 954 ft-MSL. These include Cherry Spring, Walnut Spring, and Devine Spring. Indian Spring appears to be at or above elevation 1000 ft-MSL. Together, these springs are referred to as Hill Springs, named after the two Hill brothers who were killed here by Indians.⁹⁶ Burned rock middens and flint fragments indicate that this was a preferred living site in prehistoric times. Walnut Spring and Devine Spring were visited briefly in the 1995 survey. Large numbers of Ranid and cricket frogs inhabited Walnut Spring, fewer numbers of the same species were observed at Devine Spring. Devine Spring is reported to support a population of the Texas salamander *Eurycea neotenes*. The Texas salamander is endemic to the Balcones Escarpment and adjacent portions of the Edwards Plateau of south central Texas.⁹⁷ Because the Texas salamander inhabits springs, seeps, and small cavern streams, populations are reproductively isolated which promotes genetic/evolutionary divergence. Local populations vary in coloration, size, robustness, and head shape. The Texas salamander is neotenic, retaining gills which typically are characteristic of larval salamanders. Although the Texas salamander is not listed as an endangered or threatened species, because it inhabits isolated springs, it is listed as S3 ("Rare or uncommon in state, 21 to 100 occurrences") by TPWD and C2 (candidate, Category 2, consideration for threatened/endangered status may be appropriate, however, data are insufficient to support immediate preparation of rules) by USFWS.

⁹⁶ Brune, Gunnar. 1981. Springs of Texas. Volume I. Branch-Smith, Inc., Fort Worth.

⁹⁷ Conant, R. 1975. A Field Guide to Reptiles and Amphibians of Eastern and Central North America. Houghton Mifflin Company, Boston.

The proposed project would flood about 18 miles of rocky creek bed on Cibolo, West Fork and Clear Creeks. The beds of these creeks are classified on National Inventory Wetland maps as riverine, intermittent, and temporarily or seasonally flooded. Based on field observations, aerial photographs, and NWI maps, it was estimated that the project would inundate about 468 acres of stream bed. Acquisition and preservation of comparable acreage of riverine habitat could be required.

Estimated mitigation costs for the proposed Upper Cibolo Creek Reservoir are presented in Table 3.48-1. These estimates are based on a maximum normal reservoir level of 954 ft-MSL. Environmental report costs include baseline surveys, a comprehensive Environmental Assessment, and permit support. Items marked "YES" indicate those where the likely requirements for additional effort (instream flows, endangered species, etc.) are expected to contribute significantly to environmental report costs. Mitigation land costs were estimated based on \$1,500 per acre for the 3,400 acres expected to be impacted by the maximum normal pool elevation of the proposed reservoir. Because mitigation acreage is typically negotiated with the resource agencies and will depend on reservoir site characteristics and the availability of mitigation sites, more precise estimates of mitigation land costs are not possible or justified at this time. Management costs are based on \$10/acre/year and are in addition to any preparatory work (e.g., fence construction) required before acceptance by a management agency. In order to estimate cost for investigating possible National Register sites, it was assumed that 12 sites would be surveyed for \$20,000 each. To estimate archaeological mitigation costs, it was assumed that eight of these sites would be found to be eligible for the National Register.

Additional environmental and socioeconomic concerns include the possible effects of the project on Bracken Bat Cave, the world's largest bat roost, and Natural Bridge Caverns located within two miles of the reservoir. Natural Bridge Caverns receives in excess of 300,000 visitors annually. Concerns regarding the effects of a proposed Upper Cibolo Creek reservoir have been raised previously.⁹⁸ A study performed for the Edwards Underground Water District cautioned that "it should be very apparent that since the caverns experience water level changes at present, it would be very difficult, without an extensive study and monitoring system, to prove that a

⁹⁸ Op. Cit. Espey, Huston & Associates, Inc. 1982.

Table 3.48-1	
Cost Estimates for the Study and Mitigation of Upper Cibolo Creek Reservoir Project	
<i>Item</i>	<i>Totals</i>
Total Acreage of Maximum Normal Reservoir Pool	3,400
Environmental Report	\$150,000
Threatened & Endangered Species Survey	Yes
Endangered Species Act, Section 7 Consultation	Yes
Instream Flow Studies	Yes
Environmental Mitigation	Yes
Land Acquisition for Mitigation	\$5,100,000
Habitat Evaluations Procedures Analysis (HEP)	3,500
Management (1 year)	33,000
Geomorphology	20,000
Archaeology	66,000
National Register	240,000
Archaeological Mitigation	300,000
USCE Section 404 Permit	250,000
Total	\$6,162,500

recharge structure did not affect those levels.”⁹⁹ In recent correspondence, the National Park Service proposes to recommend that Natural Bridge Caverns be listed as a threatened site in the "Damaged and Threatened National Natural Landmarks" report which they prepare annually for Congress.¹⁰⁰ If the proposed project proceeds, extensive studies would be required to document the potential effects of the reservoir on Bracken Bat Cave and Natural Bridge Caverns.

3.48.4 Water Quality and Treatability

[To be completed in subsequent phases of the study.]

3.48.5 Engineering and Costing

Conceptual dam and spillway designs were developed for impounding the proposed 150,000 acft reservoir and safely passing flood flows generated within the 260 square mile

⁹⁹ Op. Cit., Espey, Huston & Associates, Inc., 1982.

¹⁰⁰ Letter to Reginald Wuest, Vice President, Natural Bridge Caverns from Joe Sovick, U.S. Dept. of Interior, National Park Service, SW Region, Santa Fe, NM, dated August 1, 1995.

watershed above the dam. The selected dam type consists of a zoned earth and rock fill embankment utilizing a relatively thin central clay core, interior random zones, and rock fill shells (see Figure 3.48-3). An excavated core trench backfilled with clay, combined with an extensive foundation grouting program, would be necessary to provide a seepage barrier beneath the dam. An alternative dam and spillway configuration was considered for cost comparison. This alternative consisted of a roller compacted concrete (RCC) gravity dam and overflow spillway section adjacent to the steep left (east) abutment and extending approximately 1,500 feet across the creek. An embankment dam connected the RCC section with the right (west) abutment. This composite dam arrangement proved to be more expensive than the selected concept, however, and was dropped from further consideration.

The spillway system associated with the dam consists of a 300-foot wide concrete ogee crest and chute principal spillway and a 1,500-foot wide earth/rock cut auxiliary spillway excavated in a topographic saddle approximately 500 feet northeast of the dam (see Figure 3.48-4). The crest elevation for the principal spillway, 954 ft-MSL, establishes the maximum normal level of the reservoir. Estimated runoff volumes and peak inflow rates associated with the 100-year and probable maximum flood events were obtained from HDR files for ongoing studies.¹⁰¹ Hydrologic routing of these flood events in order to select appropriate spillway elevations and dimensions was performed using the HEC-1 Flood Hydrograph Package¹⁰² developed by the U.S. Army Corps of Engineers. The principal spillway would pass the 100-year flood event with the reservoir rising to elevation 964.9 ft-MSL. Larger floods would engage the auxiliary spillway, which has a crest elevation of 965 ft-MSL. The dam crest elevation of 978 ft-MSL was established to safely pass the probable maximum flood with 2.5 feet of freeboard on the dam at the maximum flood stage in the reservoir.

An outlet works structure consisting of a concrete intake tower in the reservoir, a 72-inch diameter conduit beneath the embankment, and a stilling basin structure to dissipate energy on the downstream end of the conduit was incorporated into the dam (see Figure 3.48-3). This facility would be used to make releases to Cibolo Creek and would satisfy Texas Natural Resource

¹⁰¹ HDR Engineering, Inc., "Guadalupe-San Antonio River Basin Recharge Enhancement Study, Phase II," Edwards Underground Water District, in progress.

¹⁰² Hydrologic Engineering Center, "HEC-1 Flood Hydrograph Package," U.S. Army Corps of Engineers, Davis, California, September, 1990.

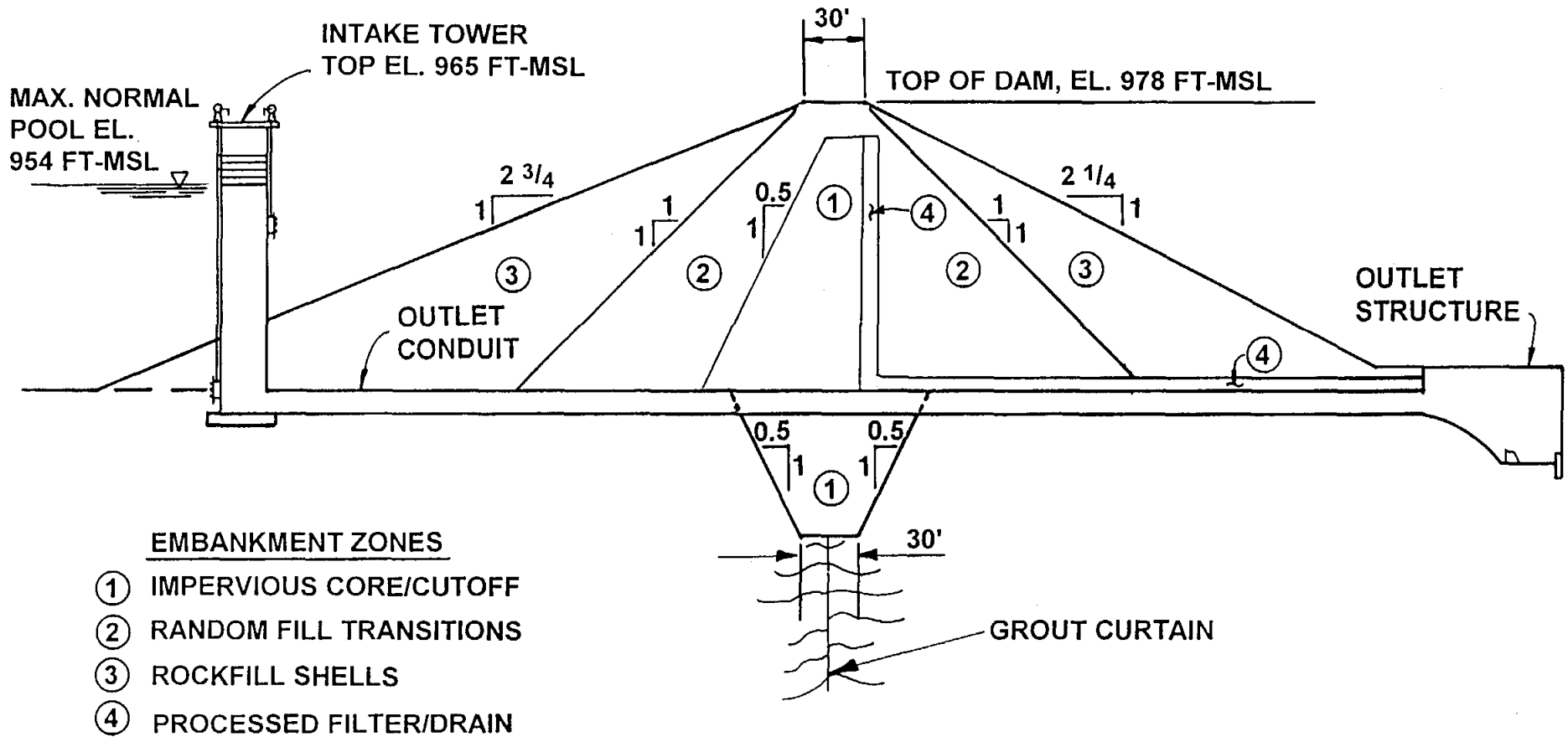

TRANS TEXAS WATER PROGRAM /
WEST CENTRAL STUDY AREA

**CONCEPTUAL EMBANKMENT
DAM SECTION**



HDR Engineering, Inc.

FIGURE 3.48-3

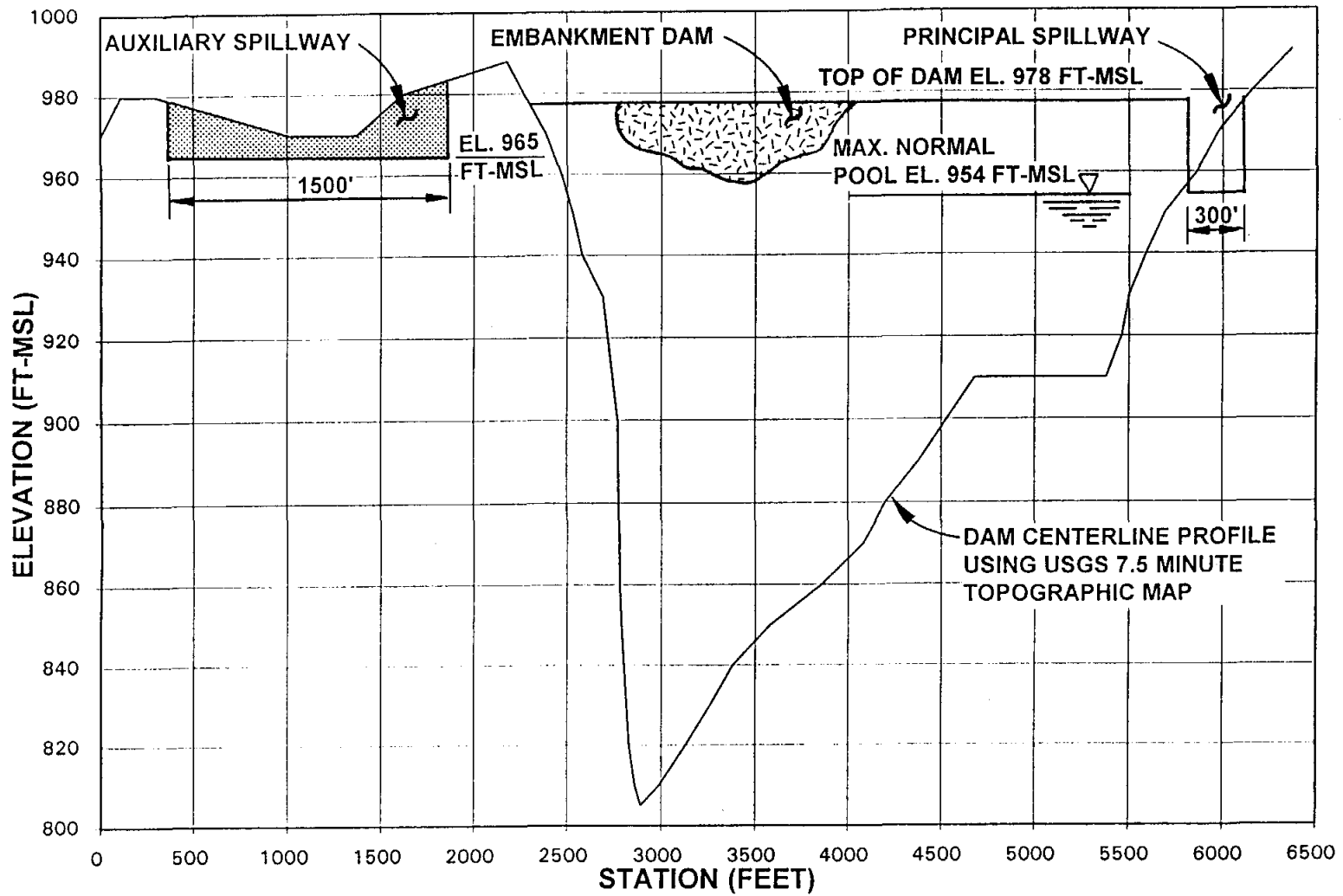

NOTE:
 PROFILE IS SHOWN LOOKING DOWNSTREAM.



HDR Engineering, Inc.

TRANS TEXAS WATER PROGRAM /
 WEST CENTRAL STUDY AREA

UPPER CIBOLO CREEK DAM
 CENTERLINE PROFILE

FIGURE 3.48-4

Conservation Commission (TNRCC) requirements for a low-level drain to empty the reservoir in the event of an emergency.

A computer program was used to calculate construction material quantities for the various embankment zones, foundation excavation and grouting, and reinforced concrete and conduit length for the outlet works structure. The program utilizes key elevations, slopes, and dimensions of the conceptual design in conjunction with the centerline profile for the dam site, which was obtained from USGS 7.5 minute topographic maps. Unit cost data for the various construction materials are used in the spreadsheet to compute a cost for each major item and a total cost for the dam and outlet works structure. The total cost for the dam and outlet works structure is estimated to be \$25,500,000 (see Table 3.48-2).

A separate cost estimate was prepared for the principal spillway using historical cost information for the type of spillway anticipated to be constructed at this site. For a reinforced concrete ogee crest and chute type spillway, a unit cost of \$15,000 per lineal foot of crest width was deemed reasonable. The estimated cost for the 300-foot wide concrete principal spillway is \$4,500,000. The cost of excavating earth and rock for the 1,500-foot wide emergency spillway is assumed to be included in the unit cost of random and rock fill zones placed within the dam.

Impoundment of the proposed reservoir to elevation 954 ft-MSL would necessitate relocating FM 1863 where it crosses the upper end of the reservoir. A cost estimate was prepared to relocate the road above the 100-year flood elevation of 965 ft-MSL. Using historical cost information for State Highway construction, the total cost to relocate FM 1863 is estimated to be \$1,700,000.

Other relocations associated with the proposed reservoir were determined by examining the USGS 7.5 minute topographic maps. Items identified on the maps include seven structures (exact type unknown), a lookout tower, two cemeteries, and approximately 1,000 linear feet of natural gas pipeline. The total cost for relocation of these items is estimated to be \$1,400,000, not including the cost of land.

It was assumed that land for Upper Cibolo Creek Reservoir would be purchased up to the 100-year flood elevation of about 965 ft-MSL. It was further assumed that a restrictive flood easement would be obtained for the area between the 100-year flood level and the maximum flood stage elevation of 975.5 ft-MSL. A composite purchase price of \$1,500 per acre for land was

Table 3.48-2
Cost Estimate for Upper Cibolo Creek Reservoir
(Mid 1994 Prices)

Item	Alternative S-17 Costs
Capital Costs	
Embankment Dam	\$ 24,500,000
Principal Spillway	4,500,000
Outlet Works	1,000,000
Reservoir Seal and Recharge Facilities	70,500,000
Relocations	<u>3,100,000</u>
Total Capital Cost	\$103,600,000
Engineering, Contingencies, and Legal Costs	36,260,000
Land Acquisition	6,865,500
Environmental Studies and Mitigation	6,612,500
Interest During Construction	<u>15,335,000</u>
Total Project Cost	\$168,673,000
Annual Costs	
Annual Debt Service	\$ 15,805,000
Annual Operation and Maintenance	<u>1,500,000</u>
Total Annual Cost	\$ 17,305,000
Available Project Yield (acft/yr)	8,700¹
Annual Cost of Water (\$/acft/yr)	\$1,989²
¹ Conventional firm yield based on operation as a traditional surface water supply reservoir without imported water.	
² Cost is for natural recharge of the conventional firm yield and does not include treatment and delivery systems.	

adopted based on recent sales in the area and data from Texas A&M University.¹⁰³ A price of \$1,200 per acre (80 percent of the land cost) was used for the restrictive flood easement area. The total cost of land for the dam and reservoir is estimated to be \$6,865,500.

A crucial element of this proposed project is the design and construction of methods to properly seal the reservoir to prevent uncontrolled leakage into the Edwards Aquifer, thereby

¹⁰³ Texas A&M University, "Rural Land Values in the Southwest: Second Half, 1994," Technical Report No. 1071, Real Estate Center, April, 1995.

ensuring that water stays in storage during times of prolonged drought for controlled recharge of the aquifer. A large portion of the reservoir lies within the four hydrostratigraphic members of the Kainer Formation. These members, in ascending order, include the Basal Nodular, Dolomitic, Kirschberg, and Grainstone. The lower three members exhibit significant porosity and permeability. The Grainstone is the least porous and permeable of the Kainer members. Porous and permeable zones in these rocks are associated with fractures and honeycombs which appear to be distributed erratically throughout the Kainer Formation, suggesting that these zones are likely to be in hydraulic communication with each other. For the purposes of this study, it was assumed that the Kainer Formation within the reservoir would have to be sealed below elevation 954 ft-MSL to minimize uncontrolled recharge of the Edwards Aquifer.¹⁰⁴ The reservoir area to be sealed is approximately 1,400 acres, based on geologic maps prepared by the U.S. Geological Survey (USGS) for Bexar and Comal Counties. This represents about 40 percent of the area inundated at the normal pool elevation of 954 ft-MSL. The remaining 60 percent of the area inundated lies primarily atop the Glen Rose Formation, which is assumed for the purposes of this study to be impermeable. Extensive geologic studies and field investigations would need to be conducted to assess the Glen Rose Formation in the reservoir area.

From an hydrogeological perspective, there are several significant issues which cannot be addressed by this limited study if the proposed reservoir is to be considered for construction in one of the most karstified areas of Texas. The issues that would need to be explored in detail include: 1) Whether sealing of the Glen Rose Formation above Bat Cave fault will be required in areas where the rock exhibits faulting and fracturing; 2) Whether there will be impacts to water levels within Natural Bridge Caverns and Bat Cave; 3) Whether the Edwards Aquifer can be effectively sealed over the life of the reservoir when karstification is changing the landform with time; 4) Whether water that is recharged will reach Comal Springs or move toward Hueco and San Marcos Springs; and 5) Whether the hydraulic gradient of the Edwards Aquifer may be reversed during times of drought due to municipal and irrigation withdrawals.¹⁰⁵

From a constructability standpoint, sealing the 1,400 acres of Kainer Formation within the reservoir can be divided into four major tasks: 1) Mapping and design; 2) Clearing and grubbing;

¹⁰⁴ LBG Guyton Associates, Letter Report to HDR Engineering, Inc., September 19, 1995.

¹⁰⁵ Ibid.

3) Removal of loose rock and overburden; and 4) Sealing porous areas.¹⁰⁶ Extensive geologic mapping of the reservoir area will be critical to determine exact areas to be sealed, the availability of on-site impermeable material, and effective methods of sealing. Most of the reservoir area below elevation 954 ft-MSL (3,400 acres) would need to be cleared and grubbed to remove all vegetation and organic material. Loose rock on vertical bluffs along with rock boulders and gravel in flatter areas would need to be removed to provide a sound foundation for sealing techniques. Materials derived from this operation could be used in the random and rock fill zones of the embankment or wasted within the reservoir area. Sealing techniques adopted for these cost analyses are described as follows. On exposed rock areas steeper than about 2.5H:1V, a 4 to 6-inch thick, reinforced shotcrete seal would be applied. In flatter areas, accessible by large earthmoving equipment, a compacted clay fill seal ranging in thickness from three to six feet would be constructed. The thicknesses of the shotcrete layer and clay fill were assumed dependent on the depth of water in the reservoir in the areas to be sealed.

Estimated quantities were calculated for each major task associated with sealing the reservoir, with the exception of the mapping and design. The cost of this work is assumed to be included in the 35 percent factor for contingencies, engineering, and legal (see Table 3.48-2). Unit cost data for each major task were selected with the assistance of a heavy construction contractor.¹⁰⁷ The total cost to seal the Kainer Formation below elevation 954 ft-MSL is estimated to be \$68,000,000.

Facilities to recharge water from the reservoir into the Edwards Aquifer would need to be constructed at several locations within the reservoir. For the purposes of this study, it was assumed that three "recharge tower" structures would be erected in the reservoir and hydraulically connected to shafts drilled into the Edwards Aquifer. Sluice gates installed at various levels within each tower would permit the withdrawal of water from different depths in the reservoir depending on water quality and temperature requirements. The total cost for these facilities is estimated to be \$2,500,000.

The total capital cost for this alternative (S-17) is estimated to be \$103,600,000. With the addition of non-structural costs, the total project cost is estimated to be \$168,673,000. The

¹⁰⁶ Scudder, W.L., Letter Report to HDR Engineering, Inc., October 13, 1995.

¹⁰⁷ Ibid.

resulting annualized project cost, including operation and maintenance, is \$17,305,000 (see Table 3.48-2). For an annual firm yield of 8,700 acft, the resulting annual cost of water is \$1,989 per acft. In order to obtain additional water supply at a unit cost competitive with other natural recharge alternatives (\$500/acft/yr; see Figure ES-12, Volume 1), the yield of Upper Cibolo Creek Reservoir (when operated in conjunction with other potential water supply sources) would need to increase by a factor of 6 or more considering the costs of importing water to the reservoir.

3.48.6 Implementation Issues (S-17)

Upper Cibolo Creek Reservoir

1. It will be necessary to obtain these permits:
 - a. TNRCC Water Right and Storage permits.
 - b. U.S. Army Corps of Engineers Sections 10 and 404 dredge and fill permits for the reservoir.
 - c. GLO Sand and Gravel Removal permits.
 - d. GLO Easement for use of state-owned lands.
 - e. Coastal Coordination Council review.
 - f. TPWD Sand, Gravel, and Marl permit.
2. Permitting, at a minimum, will require these studies:
 - a. Bay and estuary inflow impact.
 - b. Habitat mitigation plan.
 - c. Environmental studies.
 - d. Cultural resource studies.
 - e. Study of impact on karst geology organisms from sustained recharge.
 - f. Other environmental studies.
3. Land will need to be acquired through either negotiations or condemnation.
4. Relocations for the reservoir include:
 - a. Highway.
 - b. Other utilities.
5. Detailed field investigation of reservoir area to determine natural and expected recharge rates. Detailed geohydrological investigations to determine if leakage or recharge from reservoir will significantly affect water levels at Natural Bridge Caverns and Bat Cave, and to determine if recharge will contribute to flows at Comal Springs.

APPENDIX J

**WATER POTENTIALLY AVAILABLE
IN THE UPPER GUADALUPE RIVER BASIN
FOR EDWARDS AQUIFER RECHARGE ENHANCEMENT**

Appendix J

Water Potentially Available in the Upper Guadalupe River Basin for Edwards Aquifer Recharge Enhancement

Over the years, a broad spectrum of alternatives have been discussed for enhancing recharge of the Edwards Aquifer in order to provide additional water supplies and sustain springflows. A number of these alternatives were evaluated in the Trans-Texas Water Program and presented in Volumes 1 and 2 of the West Central Study Area Phase I Interim Report. Five additional alternatives for Edwards Aquifer recharge enhancement focusing on availability of water for diversion in the upper portion of the Guadalupe River Basin (at or above Lake Dunlap on the Guadalupe River and Cummings Dam on the San Marcos River) were identified for consideration in Phase I of the Trans-Texas Water Program. These five general alternatives are geographically located by source or point of diversion in Figure J-1 and are listed by subsection within Appendix J as follows:

- J1 - Storage and Diversion of Unappropriated Water Upstream of Canyon Lake (G-29)
- J2 - Purchase of Canyon Lake Water for Upstream Diversion (G-30)
- J3 - Canyon Lake Storage Reallocation (G-31)
- J4 - Diversion of Canyon Lake Flood Storage from Canyon Lake (G-32)
- J5 - Water Available Below Comal and San Marcos Springs (G-33)

Each of these subsections summarizes the quantities of water potentially available for diversion under the alternative along with any pertinent assumptions.

Three specific alternatives (G-30A, G-32, and G-33A) from among the five general alternatives were selected by the sponsors for reconnaissance level engineering and costing analyses and fatal flaw evaluation of potential environmental effects. Sections 3.43, 3.44, and 3.45 (bound in this document) summarize available yield, environmental issues, engineering and costing analyses, and implementation issues associated with these three specific alternatives.

J1
Storage and Diversion of Unappropriated Water
Upstream of Canyon Lake
(G-29)

Introduction

Alternative G-29 considers storage in and diversion from the proposed reservoir formed by Guadalupe River Dam #7, located upstream of Spring Branch (Figure J-1). Guadalupe River Dam #7 (Dam #7) was originally proposed in 1953 in the "Initial Plan" of the Guadalupe-Blanco River Authority (GBRA) for the primary purpose of power development. In 1959, Dam #7 was studied as a water supply project by Forrest and Cotton, Inc. The most recent study of Dam #7 as a water supply project was completed in October, 1981 by Espey, Huston & Associates (EHA).¹ Based on the EHA study, the watershed area above the proposed reservoir site is approximately 1,124 square miles. Dam #7 would store 600,000 acre-feet (acft) and inundate approximately 12,830 acres below its proposed conservation storage level at elevation 1242 ft-MSL.

Water Availability

The Dam #7 site is located between the USGS streamflow gaging stations on the Guadalupe River at Comfort (839 sq.mi.) and Spring Branch (1,315 sq.mi.). Total flow at the Dam #7 site was estimated utilizing an intervening drainage area ratio procedure based on the area between the Comfort and Spring Branch streamflow gaging stations. Unappropriated water available at Dam #7 site was calculated using the Guadalupe - San Antonio River Basin Model² (GSA Model) with the following assumptions:

- Full subordination of hydropower water rights to Canyon Lake and of Central Power & Light's once-through cooling water right at Victoria;
- All other water rights honored including Canyon Lake storage rights;
- Return flows observed in 1988; and
- Edwards Aquifer Demand Scenarios of 200,000 acft/yr and 400,000 acft/yr.

¹ Espey, Huston & Associates, Inc. (EHA), "Upper Guadalupe River Basin Water Supply Project," Upper Guadalupe River Authority and Guadalupe-Blanco River Authority, EHA Document No. 81137-R1. October, 1981.

² HDR Engineering, Inc., "Guadalupe - San Antonio River Basin Recharge Enhancement Study," Volumes I, II, and III, Edwards Underground Water District, September, 1993.

Honoring the Canyon Lake storage rights implies that unappropriated water will only be available when Canyon Lake exceeds conservation storage capacity of 382,000 acft. Therefore, no unappropriated water would be available at Dam #7 during the drought of record (July, 1947 to February, 1958) because storage in Canyon Lake is below the conservation level during this period. Differences in water available at Dam #7 for the two Edwards Aquifer Demand Scenarios are relatively insignificant because of the project location upstream of Comal and San Marcos Springs, and because the primary factor controlling availability of unappropriated water is honoring Canyon Lake storage rights.

Contents fluctuations within the reservoir formed by Dam #7 were simulated using an original model (RESSIM) specifically written to simulate reservoir operations subject to Trans-Texas Environmental Criteria for New Reservoirs (Appendix C, Volume 2) using water availability estimates from the GSA Model. Based on water availability estimates honoring Canyon Lake storage rights and on application of environmental criteria, Dam #7 could produce a firm yield of 28,300 acft/yr. Additional analyses were performed assuming overdraft diversion rates from Dam #7. Table J1-1 and Figure J1-1 summarize water availability at Dam #7 for the two Edwards Aquifer Demand Scenarios and diversion rates ranging from the firm yield of 28,300 acft/yr to an overdraft rate of 300,000 acft/yr.

As shown in Table J1-1 and Figure J1-1, overdrafting of Dam #7 can increase average water availability over the long-term (1934-89) and during the drought (1947-56). For example, an overdraft diversion rate of 50,000 acft/yr could produce an average water availability of 45,860 acft/yr over the long-term period and 29,320 acft/yr during the drought. However, during the drought period of 1947 to 1956, most of the water would be available at the beginning of the drought and essentially no water would be available for last three years (1954-56). Likewise, a larger overdraft diversion rate such as 125,000 acft/yr could produce an average water availability of 100,500 acft/yr over the long-term and 29,400 acft/yr during the drought. For this larger overdraft diversion rate, all of the water available in the drought would be diverted during the first three years and no water would be available for the last seven years (1950-56). Figure J1-2 presents annual water availability for overdraft diversion rates of 50,000 acft/yr and 125,000 acft/yr.

**Table J1-1
Summary of Water Availability Estimates for
Guadalupe River Dam #7**

Maximum Diversion Rate (acft/yr)	Edwards Aquifer Demand Scenario of 200,000 acft/yr		Edwards Aquifer Demand Scenario of 400,000 acft/yr	
	1934-89 Average Availability (acft/yr)	1947-56 Average Availability (acft/yr)	1934-89 Average Availability (acft/yr)	1947-56 Average Availability (acft/yr)
28,300	28,300	28,300	28,300	28,300
30,000	29,720	28,820	29,720	28,820
40,000	37,940	29,840	37,940	29,840
50,000	45,860	29,320	45,860	29,320
60,000	53,990	29,850	54,010	29,950
70,000	62,230	30,980	62,190	30,780
80,000	70,250	31,090	70,340	31,420
90,000	77,210	32,030	77,440	31,940
100,000	83,930	32,190	84,240	32,480
125,000	100,090	28,570	100,470	29,430
150,000	112,520	17,130	113,140	17,720
175,000	122,310	13,930	122,980	14,010
200,000	130,430	13,740	131,160	13,790
250,000	144,140	13,230	145,270	13,280
300,000	149,160	12,610	150,470	12,670

Notes:

- 1) Assumes full subordination of hydropower water rights to Canyon Lake and subordination of CP&L's once-through cooling water right at Victoria resulting in a total Canyon Lake firm yield of 81,500 acft/yr.
- 2) All water rights (excluding hydropower water rights and CP&L's once-through cooling water right at Victoria) honored.
- 3) Return flows assumed to be set at 1988 levels.
- 4) Capacity threshold, which is the percentage of reservoir operation storage that triggers a change from normal to drought contingency operations under the Trans-Texas Environmental Criteria for New Reservoirs, was assumed to be 60 percent. Drought contingency operations provide for the release of inflows, up to the median monthly natural flow during the January, 1954 through December, 1956 historical period.
- 5) Simulated springflows from the TWDB Edwards Aquifer Model for all pumpage scenarios were adjusted to account for the difference in simulated and observed historical springflows.

As shown in Figure J1-1, average water availability during the drought (1947-57) decreases significantly for overdraft diversion rates greater than about 125,000 acft/yr. Overdraft diversion rates greater than 125,000 acft/yr produce more water prior to 1947, resulting in less water being accumulated in reservoir storage for diversion and less average availability during the drought.

**GUADALUPE RIVER DAM NO. 7
200,000 ACFT/YR AQUIFER PUMPAGE**

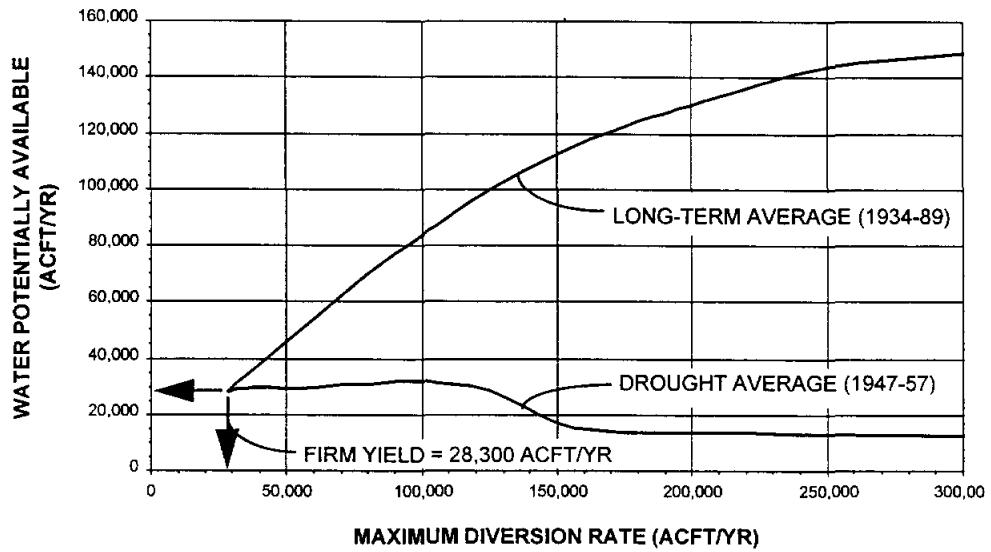

**GUADALUPE RIVER DAM NO. 7
400,000 ACFT/YR AQUIFER PUMPAGE**

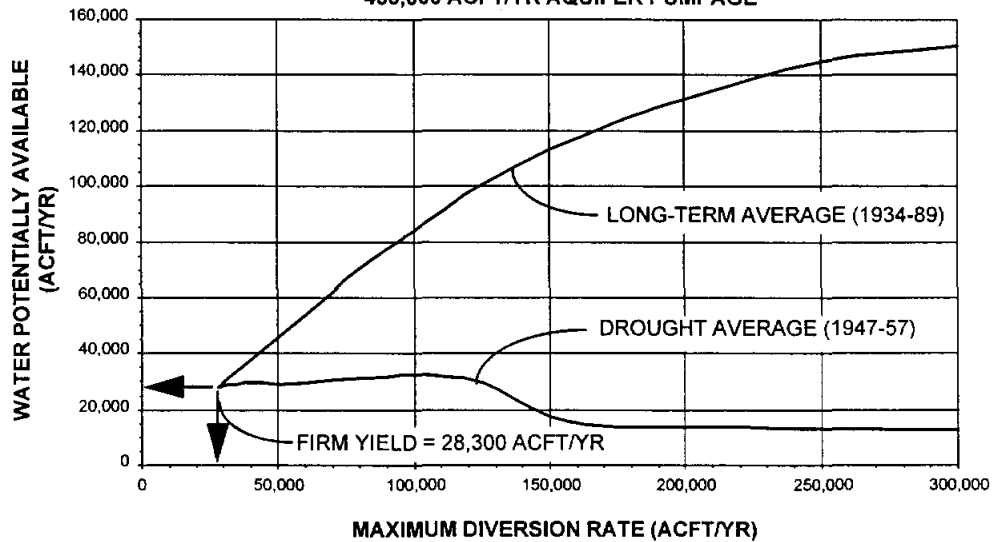

ASSUMPTIONS:

1. FIRM YIELD AND WATER AVAILABILITY BASED ON UNAPPROPRIATED STREAMFLOW SUBJECT TO ORIGINAL TRANS-TEXAS ENVIRONMENTAL CRITERIA FOR NEW RESERVOIRS.
2. HYDROPOWER WATER RIGHTS FULLY SUBORDINATED TO CANYON LAKE.
3. UNCOMMITTED FIRM YIELD OF CANYON LAKE DIVERTED NEAR NEW BRAUNFELS.
4. RETURN FLOWS SET AT RATES OBSERVED IN 1988.

TRANS TEXAS WATER PROGRAM /
WEST CENTRAL STUDY AREA



**WATER AVAILABILITY
SUMMARY
ALTERNATIVE G-29**

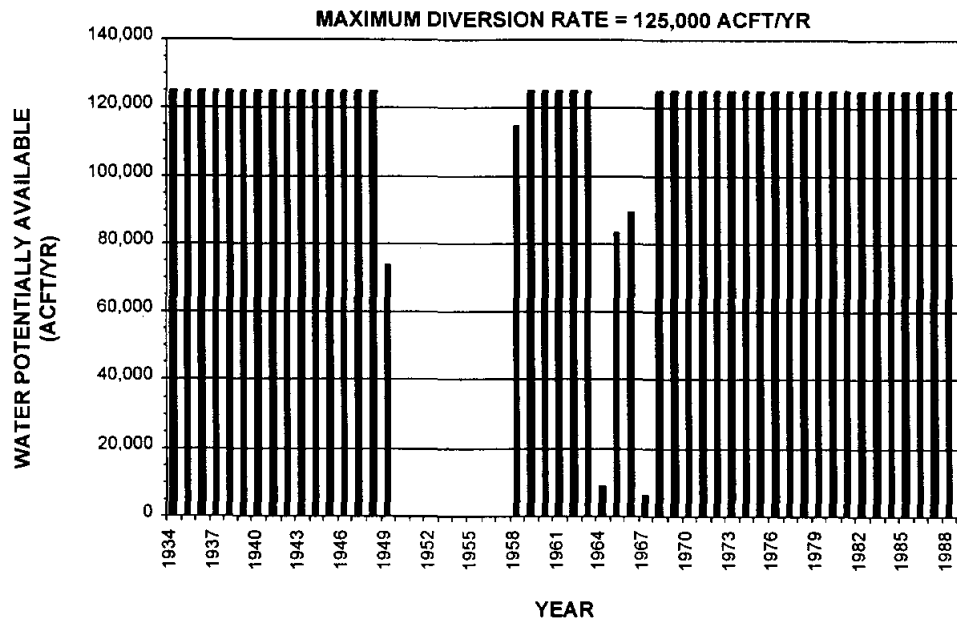
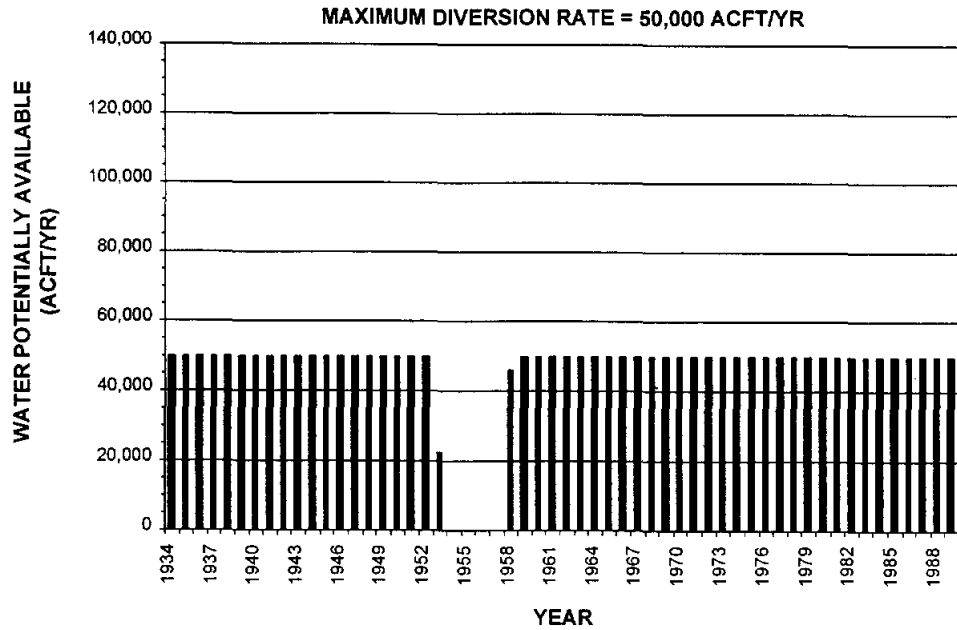

ASSUMPTIONS:

1. SPRING FLOWS RESULTING FROM FIXED EDWARDS AQUIFER PUMPAGE OF 400,000 ACFT/YR.
2. HYDROPOWER WATER RIGHTS FULLY SUBORDINATED TO CANYON LAKE.
3. UNCOMMITTED FIRM YIELD OF CANYON LAKE DIVERTED NEAR NEW BRAUNFELS.
4. RETURN FLOWS SET AT RATES OBSERVED IN 1988.
5. WATER AVAILABILITY BASED ON UNAPPROPRIATED STREAMFLOW SUBJECT TO ORIGINAL TRANS-TEXAS ENVIRONMENTAL CRITERIA FOR NEW RESERVOIRS.

**TRANS TEXAS WATER PROGRAM /
WEST CENTRAL STUDY AREA**

**WATER AVAILABILITY
EXAMPLES
ALTERNATIVE G-29**



HDR Engineering, Inc.

FIGURE J1-2

J2
Purchase of Canyon Lake Water for Upstream Diversion
(G-30)

Introduction

Alternative G-30 considers diversion of water from the Guadalupe River upstream of Canyon Lake near Comfort or near Spring Branch (Figure J-1). Diversion of water at either one of these two locations has the potential to impact the firm yield of Canyon Lake, which would necessitate a purchase agreement. Discussions of environmental issues, engineering and costing analyses, and implementation issues associated with the diversion of water from the Guadalupe River near Comfort to the Edwards Aquifer recharge zone are included in Section 3.43.

Water Availability

The two locations evaluated for diversion of water from the Guadalupe River upstream of Canyon Lake coincide with the USGS streamflow gaging stations near Comfort and near Spring Branch. Water potentially available for diversion at these two locations was computed subject to senior water rights and Trans-Texas Environmental Criteria for Instream Flows (Appendix C, Volume 2). Canyon Lake storage rights were not considered in computing availability, however, the impact of diversions on the firm yield of Canyon Lake was subsequently calculated using the GSA model. Water availability at Comfort and Spring Branch was calculated on a monthly time step using the GSA Model subject to the following assumptions:

- Full subordination of hydropower water rights to Canyon Lake and of Central Power & Light's once-through cooling water right at Victoria;
- All other water rights honored except for Canyon Lake storage rights;
- Return flows observed in 1988;
- Edwards Aquifer Demand Scenarios of 200,000 acft/yr and 400,000 acft/yr; and
- Application of Trans-Texas Environmental Criteria for Instream Flows.

Differences in water availability for the two Edwards Aquifer Demand Scenarios were insignificant because of the locations of the diversion points upstream of Canyon Lake and Comal and San Marcos Springs. Daily gaged flows for the Guadalupe River at Spring Branch (ID #1675) for the 1934-89 period were analyzed in order to determine a typical percentage of water available on a monthly basis which could be diverted on a daily basis subject to water rights, environmental flow criteria, and daily streamflow variations. This analysis indicated that, on

average, about 80 percent of the monthly volume of streamflow available for diversion from the Guadalupe River could be diverted considering the daily distribution of flows. Table J2-1 and Figure J2-1 summarize adjusted water availability at Comfort and Spring Branch for a range of diversion rates. Water availability is presented in terms of a long-term (1934-89) average and a drought (1947-56) average.

Maximum Diversion Rate (acft/yr)	Comfort		Spring Branch	
	1934-89 Average Availability (acft/yr)	1947-56 Average Availability (acft/yr)	1934-89 Average Availability (acft/yr)	1947-56 Average Availability (acft/yr)
12,000	8,210	3,240	8,160	2,660
24,000	15,250	5,150	15,670	4,370
60,000	30,580	8,770	34,540	8,980
90,000	39,210	10,510	47,070	11,680
120,000	45,780	11,710	57,410	13,700
240,000	61,590	13,770	86,840	18,350
360,000	69,140	13,770	105,080	20,660
480,000	73,140	13,770	116,070	22,660
600,000	75,900	13,770	124,260	24,070
720,000	77,610	13,770	130,670	25,070

Notes:

- 1) Assumes full subordination of hydropower water rights to Canyon Lake and subordination of CP&L's once-through cooling water right at Victoria resulting in a total Canyon Lake firm yield of 81,500 acft/yr.
- 2) All water rights honored (excluding hydropower water rights, CP&L's once-through cooling water right at Victoria, and Canyon Lake storage rights).
- 3) Return flows assumed to be set at 1988 levels.
- 4) Water availability subject to Trans-Texas Environmental Criteria for Instream Flows.
- 5) Water availability calculated on a monthly time step subject to an average daily/monthly availability percentage of 80 percent.
- 6) Water availability representative for Edwards Aquifer Demand Scenarios of 200,000 acft/yr and 400,000 acft/yr.
- 7) Simulated springflows from the TWDB Edwards Aquifer Model for all pumpage scenarios were adjusted to account for the difference in simulated and observed historical springflows.

Water availability at each diversion point varies significantly over time depending on flow conditions. Figure J2-2 and Figure J2-3 show annual water availability for Comfort and Spring Branch, respectively, for maximum diversion rates of 50,000 acft/yr and 125,000 acft/yr. As is apparent in these figures, water availability is quite limited at both diversion points during

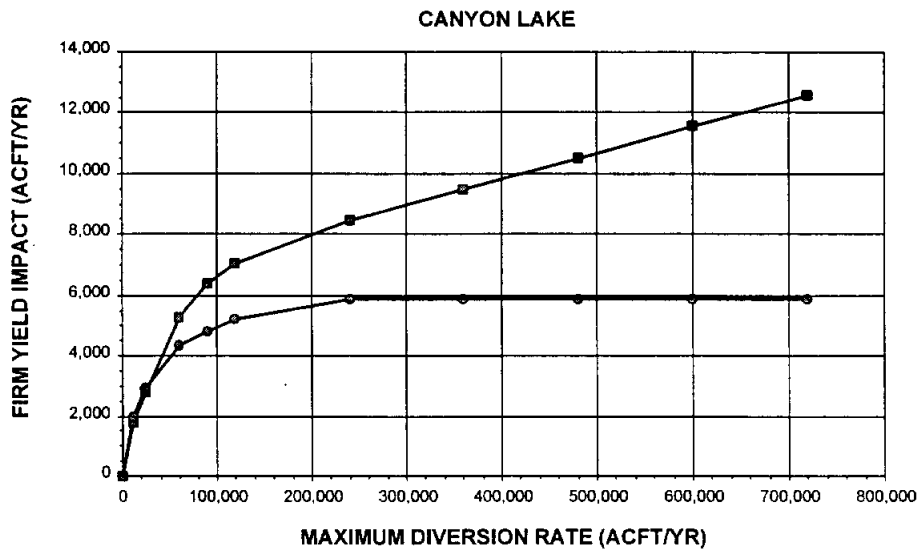
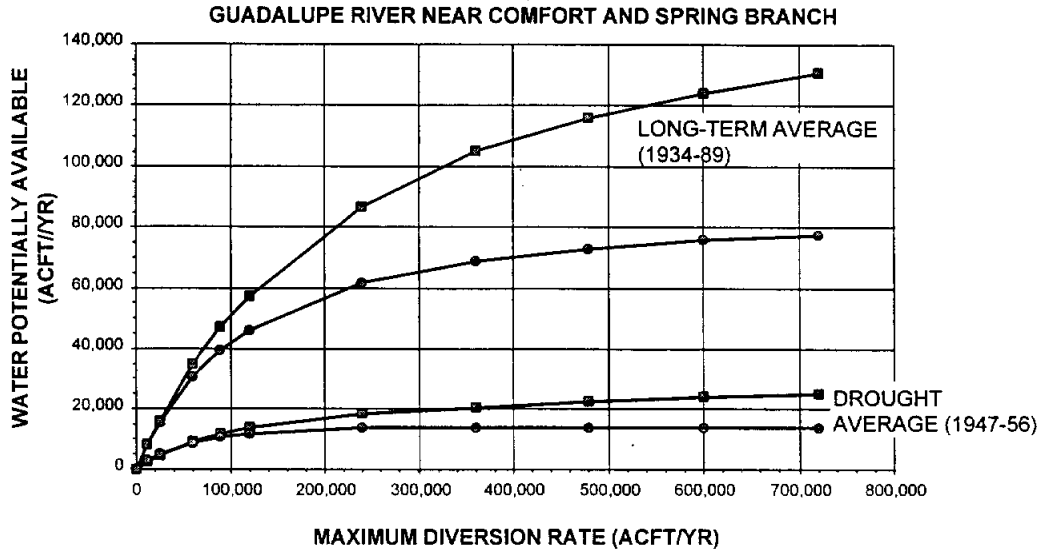

LEGEND:

- SPRING BRANCH DIVERSION
- COMFORT DIVERSION

ASSUMPTIONS:

1. SPRING FLOWS RESULTING FROM FIXED EDWARDS AQUIFER PUMPAGE OF 400,000 ACFT/YR.
2. HYDROPOWER WATER RIGHTS FULLY SUBORDINATED TO CANYON LAKE.
3. UNCOMMITTED FIRM YIELD OF CANYON LAKE DIVERTED NEAR NEW BRAUNFELS.
4. RETURN FLOWS SET AT RATES OBSERVED IN 1988.
5. IMPORT DIVERSIONS SUBJECT TO ORIGINAL TRANS-TEXAS ENVIRONMENTAL CRITERIA.

TRANS TEXAS WATER PROGRAM /
WEST CENTRAL STUDY AREA

**WATER AVAILABILITY AND
DOWNSTREAM IMPACT
SUMMARIES, ALTERNATIVE G-30**



HDR Engineering, Inc.

FIGURE J2-1

MAXIMUM DIVERSION RATE = 50,000 ACFT/YR

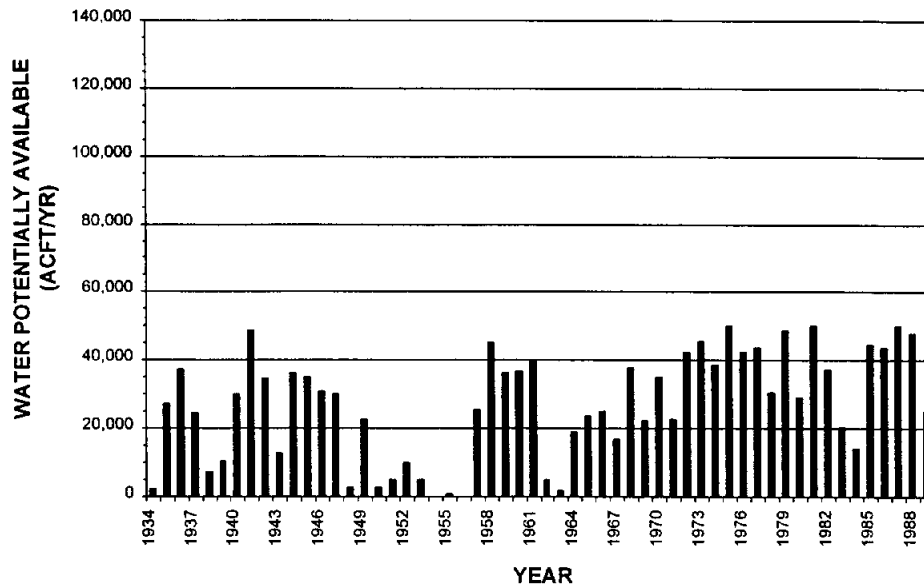

MAXIMUM DIVERSION RATE = 125,000 ACFT/YR

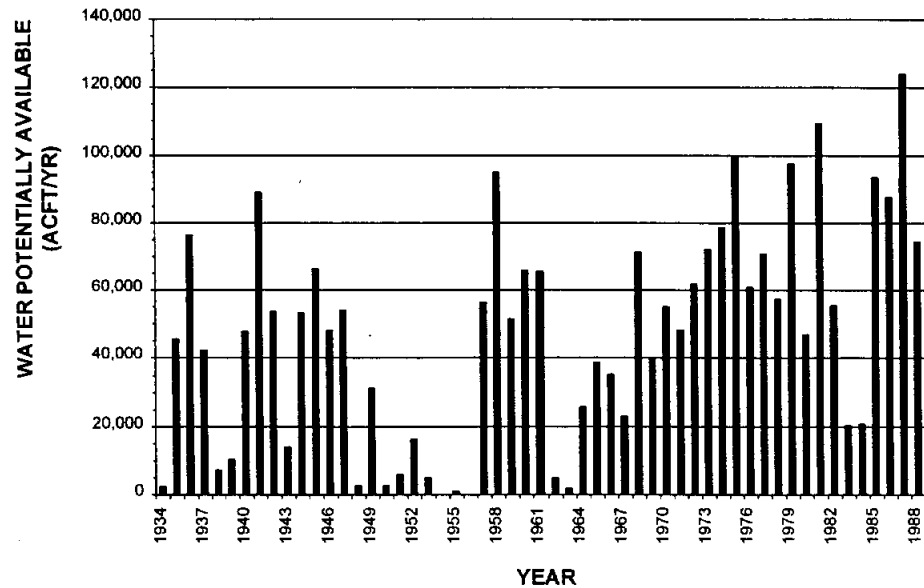

ASSUMPTIONS:

1. SPRING FLOWS RESULTING FROM FIXED EDWARDS AQUIFER PUMPAGE OF 400,000 ACFT/YR.
2. HYDROPOWER WATER RIGHTS FULLY SUBORDINATED TO CANYON LAKE.
3. UNCOMMITTED FIRM YIELD OF CANYON LAKE DIVERTED NEAR NEW BRAUNFELS.
4. RETURN FLOWS SET AT RATES OBSERVED IN 1988.
5. IMPORT DIVERSIONS SUBJECT TO ORIGINAL TRANS-TEXAS ENVIRONMENTAL CRITERIA.

TRANS TEXAS WATER PROGRAM / WEST CENTRAL STUDY AREA

WATER AVAILABILITY EXAMPLES COMFORT DIVERSION ALTERNATIVE G-30A



HDR Engineering, Inc.

FIGURE J2-2

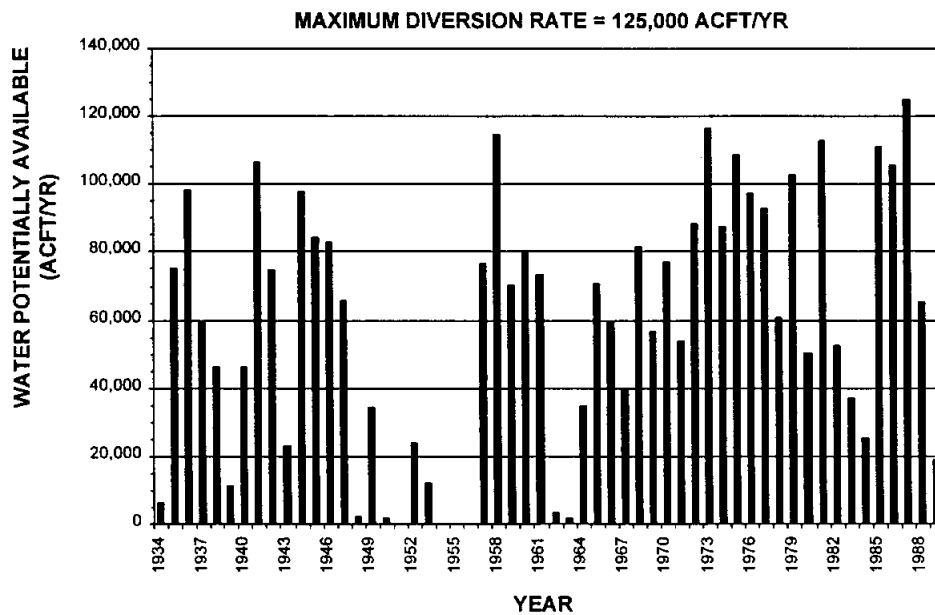
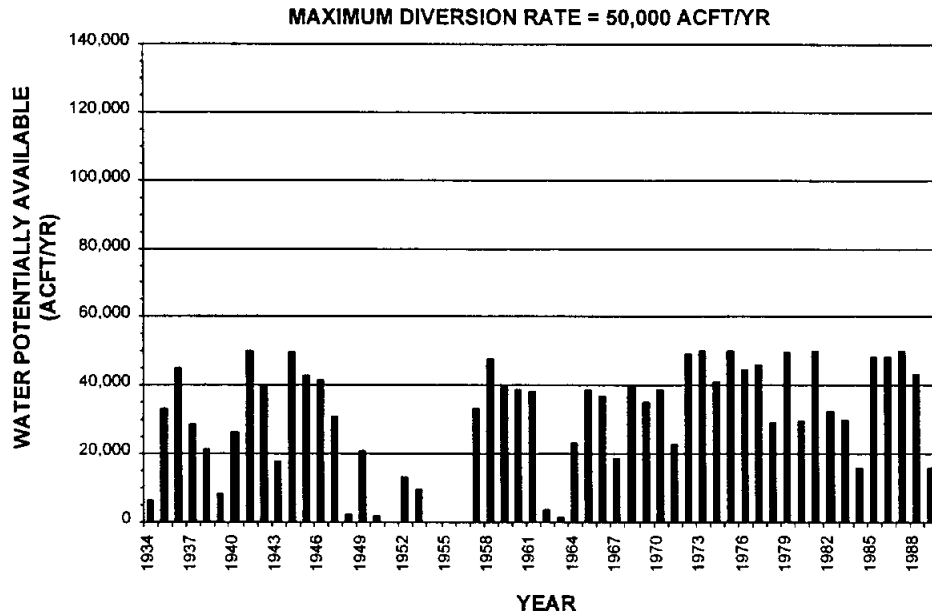

ASSUMPTIONS:

1. SPRING FLOWS RESULTING FROM FIXED EDWARDS AQUIFER PUMPAGE OF 400,000 ACFT/YR.
2. HYDROPOWER WATER RIGHTS FULLY SUBORDINATED TO CANYON LAKE.
3. UNCOMMITTED FIRM YIELD OF CANYON LAKE DIVERTED NEAR NEW BRAUNFELS.
4. RETURN FLOWS SET AT RATES OBSERVED IN 1988.
5. IMPORT DIVERSIONS SUBJECT TO ORIGINAL TRANS-TEXAS ENVIRONMENTAL CRITERIA.

TRANS TEXAS WATER PROGRAM /
WEST CENTRAL STUDY AREA

**WATER AVAILABILITY EXAMPLES
SPRING BRANCH DIVERSION
ALTERNATIVE G-30B**



HDR Engineering, Inc.

FIGURE J2-3

the drought period, especially during the last three years (1954-56). For a maximum diversion rate of 50,000 acft/yr, the full annual amount is available about seven percent of the time at Comfort and 12 percent of the time at Spring Branch. For a maximum diversion rate of 125,000 acft/yr, the full annual amount is available only about two percent of the time at Comfort and Spring Branch.

Diversion of water potentially available from the Guadalupe River at Comfort or Spring Branch would reduce inflow to Canyon Lake and impact the firm yield of Canyon Lake. The impact of diversions at Comfort and Spring Branch on the firm yield of Canyon Lake was assessed using the GSA Model for a range of maximum diversion rates. Table J2-2 and Figure J2-1 summarize the Canyon Lake firm yield impact associated with each maximum diversion rate considered.

Table J2-2		
Summary of Canyon Lake Firm Yield Impact		
Maximum Diversion Rate (acft/yr)	Canyon Lake Firm Yield Reduction (acft/yr)	
	Comfort Diversion Point	Spring Branch Diversion Point
12,000	1,970	1,780
24,000	2,970	2,770
60,000	4,360	5,290
90,000	4,820	6,380
120,000	5,230	7,040
240,000	5,900	8,460
360,000	5,900	9,490
480,000	5,900	10,520
600,000	5,900	11,560
720,000	5,900	12,600

Notes:

- 1) Assumes full subordination of hydropower water rights to Canyon Lake and subordination of CP&L's once-through cooling water right at Victoria.
- 2) All water rights honored (excluding hydropower water rights, CP&L's once-through cooling water right at Victoria)
- 3) Return flows assumed to be set at 1988 levels.
- 4) Water availability subject to Trans-Texas Environmental Criteria for Instream Flows.
- 5) Water availability calculated on a monthly time step subject to an average daily/monthly availability percentage of 80 percent.
- 6) Canyon Lake firm yield reduction is representative for Edwards Aquifer Demand Scenarios of 200,000 acft/yr and 400,000 acft/yr.
- 7) The results of the simulated springflows from the TWDB Edwards Aquifer Model for all pumpage scenarios were adjusted to account for the difference in simulated and observed historical springflows.

J3
Canyon Lake Storage Reallocation
(G-31)

Introduction

Alternative G-31 considers reallocation of Canyon Lake flood storage to conservation storage and diversion of the resultant increase in Canyon Lake firm yield directly from Canyon Lake or from Lake Dunlap. Firm yield estimates for various degrees of flood storage reallocation are presented herein. Design flood, dam safety issues, and increased flood hazard potential upstream and downstream of Canyon Dam were not evaluated in this study.

Water Availability

Canyon Lake currently has a conservation storage capacity of about 382,000 acft. Storage for flood control in Canyon Lake between the emergency spillway level (943 ft-MSL) and conservation level (909 ft-MSL) is approximately 354,664 acft which gives a total storage volume below the emergency spillway level of 736,664 acft. Various degrees of reallocation of flood storage to conservation storage were evaluated as part of this alternative. The increase in Canyon Lake firm yield due to reallocation of flood storage to conservation storage was calculated using the GSA Model subject to the following assumptions:

- Full subordination of hydropower water rights to Canyon Lake and of Central Power & Light's once-through cooling water right at Victoria;
- All other water rights honored;
- Return flows observed in 1988;
- Edwards Aquifer Demand Scenarios of 200,000 acft/yr and 400,000 acft/yr; and
- Uncommitted firm yield of Canyon Lake was assumed to be diverted from Canyon Lake or Lake Dunlap.

The critical drawdown period for Canyon Lake extends from July, 1947 to February, 1957. By reallocating flood storage to conservation storage, the storage level at the beginning of the critical drawdown period (July, 1947) would be greater, resulting in an increase in the firm yield of Canyon Lake. Table J3-1 and Figure J3-1 summarize the total firm yield of Canyon Lake for various degrees of reallocation of Canyon Lake flood storage to conservation storage for each diversion and aquifer demand scenario considered.

Table J3-1					
Summary of Canyon Lake Firm Yield for Reallocation of Flood Storage					
Canyon Lake Storage		Edwards Aquifer Demand Scenario of 200,000 acft/yr		Edwards Aquifer Demand Scenario of 400,000 acft/yr	
Total Conservation Storage (acft)	Flood Storage Reallocation (acft)	Canyon Lake Diversion Point Total Firm Yield (acft/yr)	Lake Dunlap Diversion Point Total Firm Yield (acft/yr)	Canyon Lake Diversion Point Total Firm Yield (acft/yr)	Lake Dunlap Diversion Point Total Firm Yield (acft/yr)
382,000	0	80,547	87,988	75,020	81,447
385,000	3,000	80,778	88,228	75,250	81,680
390,000	8,000	81,165	88,616	75,634	82,065
400,000	18,000	81,932	89,392	76,408	82,858
410,000	28,000	82,706	90,181	77,182	83,650
420,000	38,000	83,485	90,858	77,962	84,443
440,000	58,000	85,043	92,523	79,520	86,021
460,000	78,000	86,608	94,096	81,083	87,613
480,000	98,000	88,172	95,674	82,659	89,198
500,000	118,000	89,749	97,259	84,229	90,790
550,000	168,000	93,692	101,225	88,178	94,749
600,000	218,000	97,641	105,185	92,127	98,715
650,000	268,000	101,602	109,157	96,088	102,681
700,000	318,000	105,581	113,142	100,067	106,666
736,664	354,664	108,514	116,086	103,002	109,607

Notes:

- 1) Existing Conservation Storage of Canyon Lake is 382,000 ac-ft. Existing Canyon Lake Flood Storage is 354,664 ac-ft which results in a total storage of 736,664 ac-ft below the emergency spillway level.
- 2) Total Firm Yield represents the sum of uncommitted firm yield and existing contracts. Existing contracts were assumed to total 38,438 ac-ft/yr and the uncommitted firm yield was assumed to be diverted at the specified diversion point.
- 3) Assumes full subordination of hydropower water rights to Canyon Lake and subordination of CP&L's once-through cooling water right at Victoria.
- 4) All water rights honored (excluding hydropower and CP&L's once-through cooling water right).
- 5) Return flows assumed to be set at 1988 levels.
- 6) Simulated springflows from the TWDB Edwards Aquifer Model for all pumpage scenarios were adjusted to account for the difference in simulated and observed historical springflows.

As is apparent in Figure J3-1, the incremental increase in firm yield as a function of the volume of flood storage reallocated to conservation storage is essentially a linear relationship. This is due to the fact that inflows prior to the drought are sufficiently great to ensure that the duration of the critical drawdown period remains the same regardless of the portion of the flood storage reallocated to conservation storage. The simulated increase in firm yield is consistently in the range of 7.7 to 8.0 percent of the volume of flood storage reallocated.

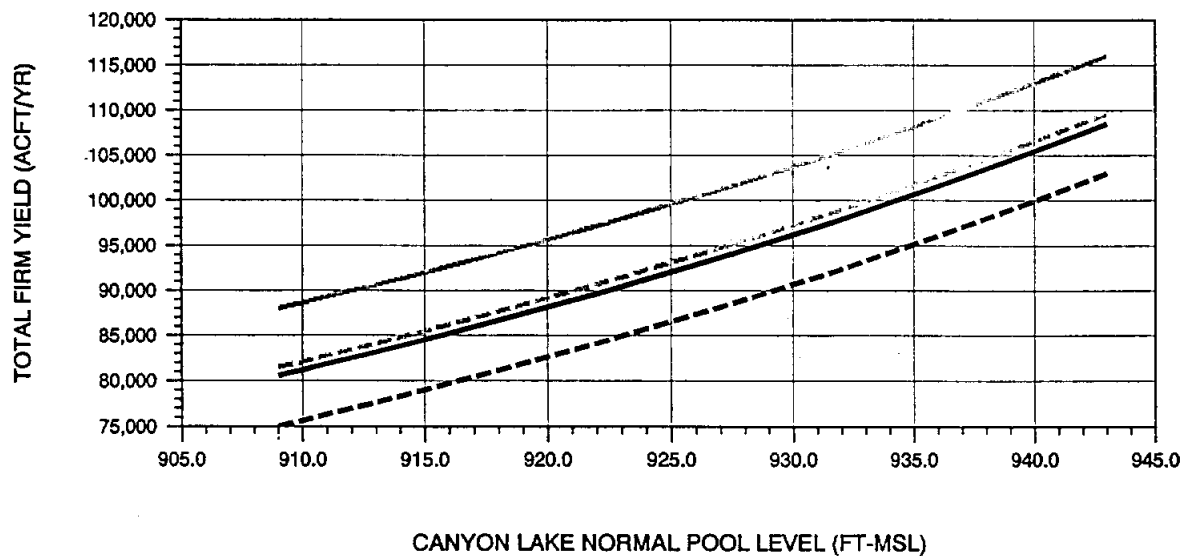
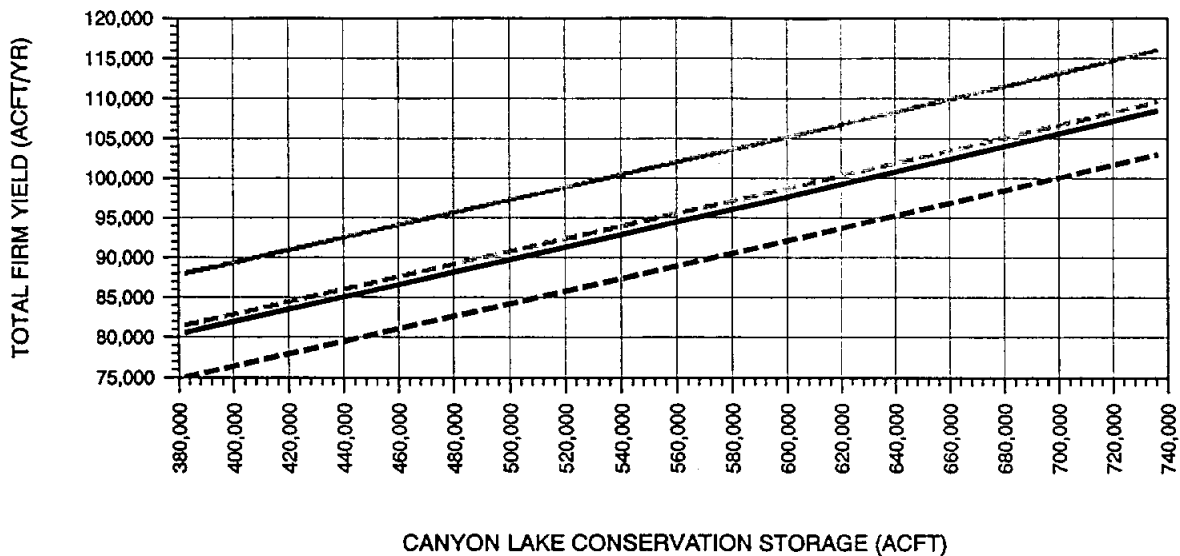

NOTES:

1. TOTAL FIRM YIELD IS THE SUM OF THE UNCOMMITTED FIRM YIELD DIVERTED AT THE SPECIFIED DIVERSION POINT (CANYON LAKE OR LAKE DUNLAP) AND EXISTING CONTRACTUAL COMMITMENTS (38,438 ACFT/YR).
2. FULL SUBORDINATION OF HYDROPOWER WATER RIGHTS.
3. CP&L'S ONCE-THRU COOLING WATER RIGHT AT VICTORIA (300CFS) FULLY SUBORDINATED.
4. 1988 RETURN FLOW CONDITIONS.
5. THE RESULTS OF THE SIMULATED SPRINGFLOWS FROM THE TWDB EDWARDS AQUIFER MODEL WERE ADJUSTED FOR THE DIFFERENCE IN THE MODEL'S SIMULATED HISTORICAL SPRINGFLOWS AND OBSERVED SPRINGFLOWS.

LEGEND:

- CANYON LAKE DIVERSION PT., 200,000 ACFT/YR AQUIFER PUMPAGE
- - - CANYON LAKE DIVERSION PT., 400,000 ACFT/YR AQUIFER PUMPAGE
- LAKE DUNLAP DIVERSION PT., 200,000 ACFT/YR AQUIFER PUMPAGE
- - - LAKE DUNLAP DIVERSION PT., 400,000 ACFT/YR AQUIFER PUMPAGE

TRANS TEXAS WATER PROGRAM /
WEST CENTRAL STUDY AREA



HDR Engineering, Inc.

CANYON LAKE
FIRM YIELD SUMMARY
ALTERNATIVE G-31

FIGURE J3-1

J4
Diversion of Canyon Lake Flood Storage from Canyon Lake
(G-32)

Introduction

During large flood events, Canyon Lake temporarily impounds a portion of the inflow in flood storage until it can be safely released without causing downstream flooding. Alternative G-32 considers direct diversions of flood storage from Canyon Lake. Design flood, dam safety issues, and increased flood hazard potential downstream of Canyon Lake were not evaluated in this study. Discussions of environmental issues, engineering and costing analyses, and implementation issues associated with the diversion of Canyon Lake flood storage to the Edwards Aquifer recharge zone are included in Section 3.44.

Water Availability

The GSA Model was modified to simulate flood pool operations in Canyon Lake subject to one specified flood release rate and one specified diversion rate. Simulations were performed on a monthly time step with the following general assumptions:

- Full subordination of hydropower water rights to Canyon Lake and of Central Power & Light's once-through cooling water right at Victoria;
- All other water rights honored;
- Return flows observed in 1988; and
- Edwards Aquifer Demand Scenarios of 200,000 acft/yr and 400,000 acft/yr.

Current guidelines for flood releases from Canyon Lake are set forth in Schedule #1 from the U.S. Army Corps of Engineers Reservoir Regulation Manual. These guidelines generally provide for the release of 1,500 cfs (2,975 acft/day) when the lake level is between 909 ft-MSL and 911 ft-MSL and 5,000 cfs (9,920 acft/day) when the lake level exceeds 911 ft-MSL. For this alternative, flood release rates of 500 cfs, 1,000 cfs, and 5,000 cfs were considered along with flood pool diversion rates ranging from 11,372 acft/yr (16 cfs) to 720,000 acft/yr (995 cfs). Diversions from Canyon Lake flood storage and fixed flood releases were assumed to occur simultaneously in the GSA Model. Hence, any delays in initiating flood releases or variable flood release rates as

described in the current guidelines could increase the estimates of water availability presented herein.

Annual long-term (1934-89) averages of water potentially available for diversion from the flood storage of Canyon Lake subject to three fixed flood release rates, two Edwards Aquifer Demand Scenarios, and a range of maximum diversion rates are presented in Figure J4-1. As is apparent in Figure J4-1, pumpage from the Edwards Aquifer (within the range considered) has no significant effect on water availability for this alternative due to the diversion location above Comal and San Marcos Springs. Figure J4-2 illustrates annual water availability with a maximum diversion rate of 125,000 acft/yr (173 cfs) for flood release rates of 1,000 cfs and 5,000 cfs. Clearly, long-term average water availability from Canyon Lake flood storage could be increased significantly by reduction of the flood release rate if increased flood hazard and dam safety issues could be satisfactorily addressed. Water available for diversion varies greatly from year to year, but is non-existent during the critical drought period for Canyon Lake which is more than 10 years in duration (July, 1947 through February, 1958).

**CANYON LAKE FLOOD STORAGE
200,000 ACFT/YR AQUIFER PUMPAGE**

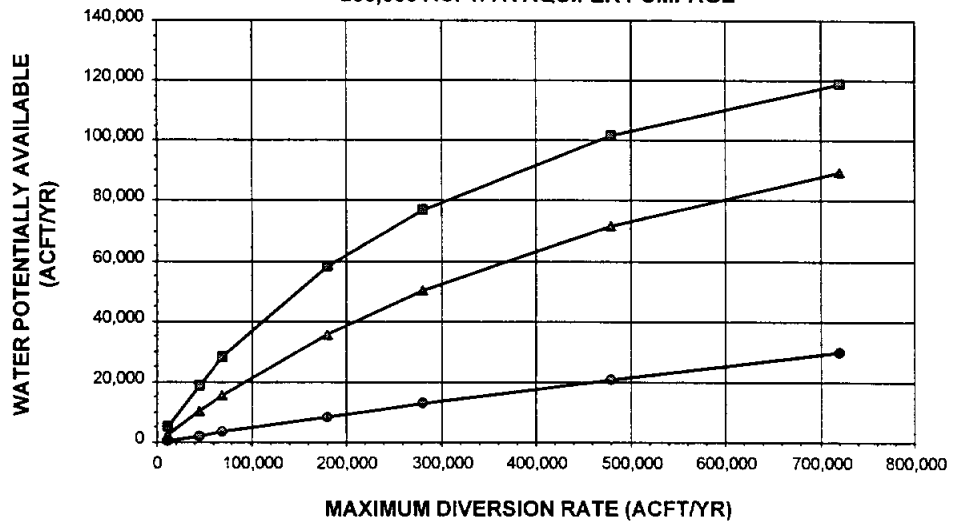

**CANYON LAKE FLOOD STORAGE
400,000 ACFT/YR AQUIFER PUMPAGE**

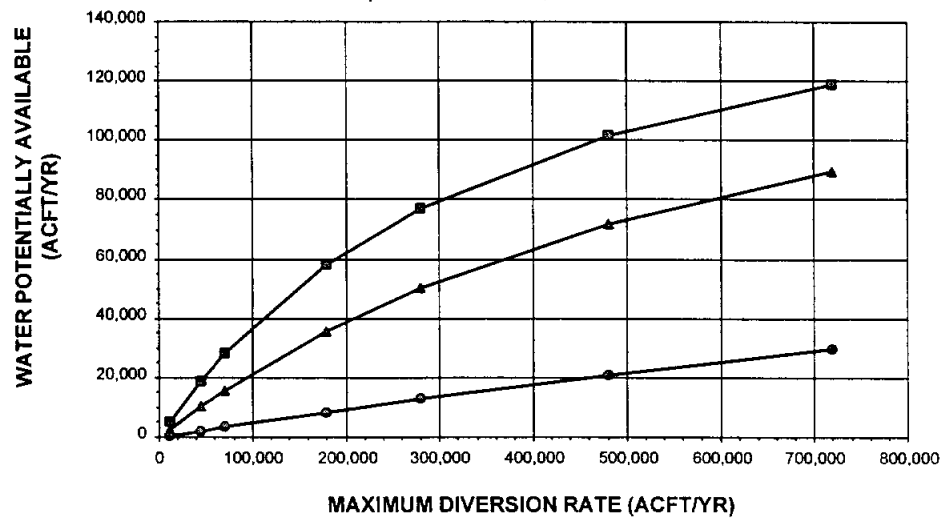

LEGEND:

- 500 CFS FLOOD RELEASE RATE
- ▲ 1,000 CFS FLOOD RELEASE RATE
- 5,000 CFS FLOOD RELEASE RATE

ASSUMPTIONS:

1. FLOOD STORAGE DIVERSIONS AT MAXIMUM RATE OCCUR SIMULTANEOUSLY WITH FLOOD RELEASES AT CANYON DAM.
2. HYDROPOWER WATER RIGHTS FULLY SUBORDINATED TO CANYON LAKE.
3. UNCOMMITTED FIRM YIELD OF CANYON LAKE DIVERTED NEAR NEW BRAUNFELS.
4. RETURN FLOWS SET AT RATES OBSERVED IN 1988.

TRANS TEXAS WATER PROGRAM /
WEST CENTRAL STUDY AREA



HDR Engineering, Inc.

**WATER AVAILABILITY
SUMMARY
ALTERNATIVE G-32**

FIGURE J4-1

MAXIMUM DIVERSION RATE = 125,000 ACFT/YR
1,000 CFS FLOOD RELEASE RATE

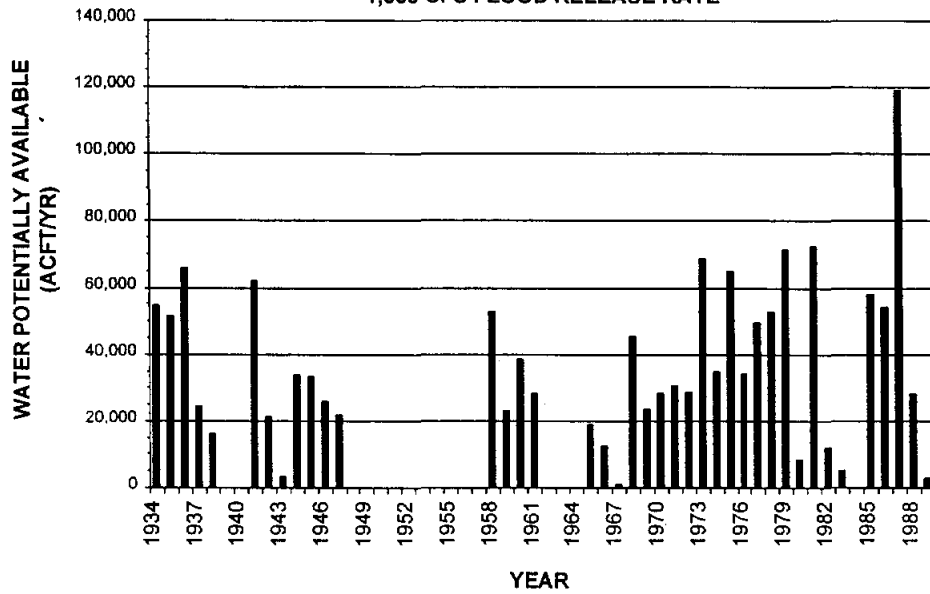

MAXIMUM DIVERSION RATE = 125,000 ACFT/YR
5,000 CFS FLOOD RELEASE RATE

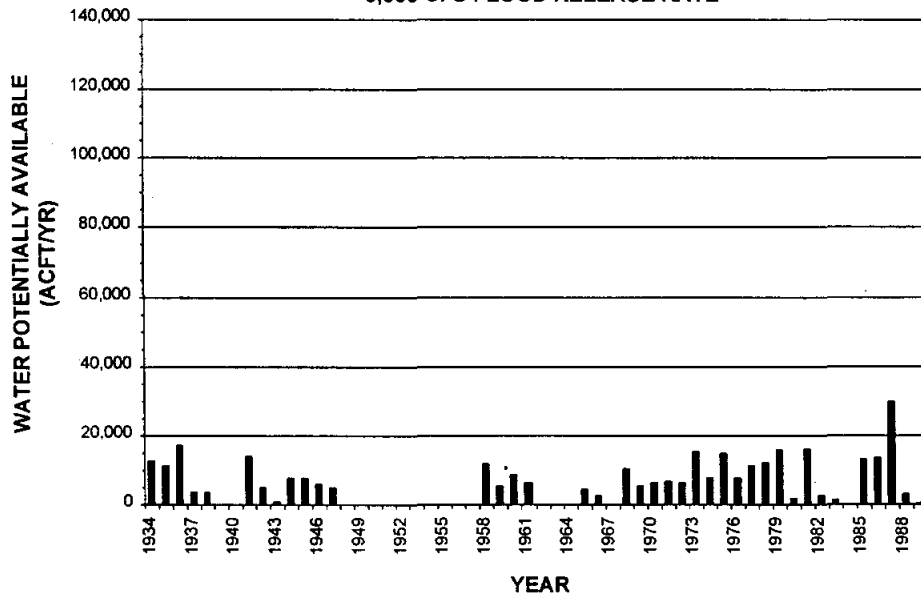

ASSUMPTIONS:

1. FLOOD STORAGE DIVERSIONS AT MAXIMUM RATE OCCUR SIMULTANEOUSLY WITH FLOOD RELEASES AT CANYON DAM.
2. SPRINGFLOWS RESULTING FROM FIXED EDWARDS AQUIFER PUMPAGE OF 400,000 ACFT/YR.
3. HYDROPOWER WATER RIGHTS FULLY SUBORDINATED TO CANYON LAKE.
4. UNCOMMITTED FIRM YIELD OF CANYON LAKE DIVERTED NEAR NEW BRAUNFELS.
5. RETURN FLOWS SET AT RATES OBSERVED IN 1988.

TRANS TEXAS WATER PROGRAM /
WEST CENTRAL STUDY AREA

**WATER AVAILABILITY EXAMPLES
ALTERNATIVE G-32**



HDR Engineering, Inc.

FIGURE J4-2

J5
Water Available Below Comal and San Marcos Springs
(G-33)

Introduction

Alternative G-33 considers diversion of water from the Guadalupe River below Comal Springs at Lake Dunlap (G-33A) and from the San Marcos River below San Marcos Springs at Cummings Dam (G-33B). Water potentially available for diversion at these locations would be obtained from three primary sources: 1) Enhanced springflow resulting from a reduction in overall Edwards Aquifer pumpage from that observed in calendar year 1989 (543,677 acft)³ to 400,000 acft/yr or 200,000 acft/yr; 2) The unutilized portion (based on calendar year 1989) of existing water rights throughout the Guadalupe - San Antonio River Basin; and 3) Unappropriated streamflow subject to senior water rights and Trans-Texas Environmental Criteria. Discussions of environmental issues, engineering and costing analyses, and implementation issues associated with the diversion of water from below Comal Springs at Lake Dunlap to the Edwards Aquifer recharge zone are included in Section 3.45.

Water Availability

Water potentially available for diversion below Comal and San Marcos Springs (under assumptions presently applicable only to this alternative) is comprised of enhanced springflow, flow committed to existing water rights (permitted, but unutilized in calendar year 1989), and unappropriated streamflow. The procedures and assumptions pertinent to the computation of water potentially available from each of these sources are described in the following subsections.

Enhanced Springflow

Approximations of increases in springflow resulting from potential reductions in Edwards Aquifer pumpage from the amount observed in calendar year 1989 (543,677 acft) were obtained using the Edwards Aquifer Model developed and maintained by the Texas Water Development Board (TWDB).⁴ In response to a request from the Policy Management Committee for the West Central Study Area, TWDB staff applied the model to simulate springflows resulting from a fixed

³ TWDB, Personal Communication, August 22, 1995.

⁴ Texas Water Development Board, "Ground-water Resources and Model Applications for the Edwards (Balcones Fault Zone) Aquifer in the San Antonio Region," Report 239, October, 1979.

annual Edwards Aquifer pumpage of 543,677 acft. Simulated springflows from the TWDB Edwards Aquifer Model for this pumpage scenario were adjusted to account for monthly differences in simulated and actual springflows based on historical pumpage. Springflows based on pumpage of 543,677 acft/yr were compared to those for 400,000 acft/yr and 200,000 acft/yr (previously provided by the TWDB⁵) to estimate monthly quantities of enhanced springflow at Comal, San Marcos, and other springs originating in the Edwards Aquifer. Long-term and drought average increases in springflow derived from these comparisons are presented in Table J5-1 for Comal and San Marcos Springs.

Table J5-1 Enhanced Springflow at Comal and San Marcos Springs				
Edwards Aquifer Pumpage (acft/yr)	Enhanced Springflow (acft/yr)			
	Comal Springs		San Marcos Springs	
	Long-Term Average	Drought Average	Long-Term Average	Drought Average
543,677	-0-	-0-	-0-	-0-
400,000	84,500	40,400	11,900	14,400
200,000	188,200	145,000	21,100	24,000

NOTES:

1. Enhanced springflows computed relative to springflows based on calendar year 1989 pumpage of 543,677 acft.
2. Simulated springflows from the TWDB Edwards Aquifer Model for all pumpage scenarios were adjusted to account for the difference in simulated and observed historical springflows.
3. Long-term average based on 1934-89 historical period.
4. Drought average based on 1947-56 historical period.

In order to estimate the portion of this enhanced springflow potentially available for diversion below the springs after honoring downstream water rights, it was first necessary to determine the baseline firm yield of Canyon Lake subject to Edwards Aquifer pumpage of 543,677 acft/yr. Assuming full subordination of Guadalupe River hydropower water rights to Canyon Lake and return flows at rates reported for 1989, the uncommitted firm yield of Canyon Lake diverted at Lake Dunlap would be 40,200 acft/yr after honoring Guadalupe-Blanco River Authority (GBRA) contractual commitments from Canyon Lake totaling 38,438 acft/yr. Releases, spills, and firm yield diversions from this simulation were held constant in all water availability analyses for Alternative G-33. Hence, it was assumed that any increases in springflow resulting from the reduction of Edwards Aquifer pumpage would not accrue to Canyon Lake storage and firm yield, but could accrue to downstream consumptive water rights. Furthermore,

⁵ HDR Engineering, Inc., "Guadalupe - San Antonio River Basin Recharge Enhancement Study," Edwards Underground Water District, September, 1993.

flows past the Saltwater Barrier from this baseline simulation were preserved when quantifying water potentially available for diversion under both enhanced springflow and existing water rights transfers.

For informational purposes, Canyon Lake firm yields, reductions in drought average shortages for existing water rights, and increases in drought average flows entering the Guadalupe Estuary at the Saltwater Barrier near Tivoli were computed assuming enhanced springflow would accrue to both Canyon Lake storage and existing water rights. The results of these computations are presented in Figure J5-1. Allowing enhanced springflow to accrue to Canyon Lake storage, Canyon Lake firm yield would increase by up to 9,800 acft/yr (12 percent), water rights shortages during drought would decrease by up to 17,200 acft/yr (33 percent), and flows at the Saltwater Barrier would increase by up to 95,000 acft/yr (20 percent) if Edwards Aquifer pumpage were reduced to 200,000 acft/yr. By not allowing enhanced springflow to accrue to Canyon Lake storage, Canyon Lake firm yield would remain unchanged, water rights shortages during drought would be decreased to amounts comparable to those illustrated in Figure J5-1, and flows at the Saltwater Barrier would be increased to amounts significantly greater than those illustrated in Figure J5-1 if Edwards Aquifer pumpage were reduced from 543,677 acft/yr.

The Guadalupe - San Antonio River Basin Model⁶ (GSA Model) was used to compute water availability below Comal Springs at Lake Dunlap and below San Marcos Springs at Cummings Dam for Edwards Aquifer pumpage scenarios of 543,677 acft/yr, 400,000 acft/yr, and 200,000 acft/yr subject to existing water rights and contracts and a range of maximum monthly diversion rates. Month by month comparison of water availability estimates under the aquifer pumpage scenarios reveals the balance of enhanced springflow available for diversion assuming existing surface water rights are honored first. Over the long-term (1934-89), these comparisons indicate that between 96 percent and 100 percent of the total enhanced springflow at Comal or San Marcos Springs could be available for diversion after honoring existing surface water rights. During drought (1947-56), these comparisons indicate that between 87 percent and 89 percent of the total enhanced springflow at Comal Springs or between 62 percent and 75 percent of the total

⁶ Ibid.

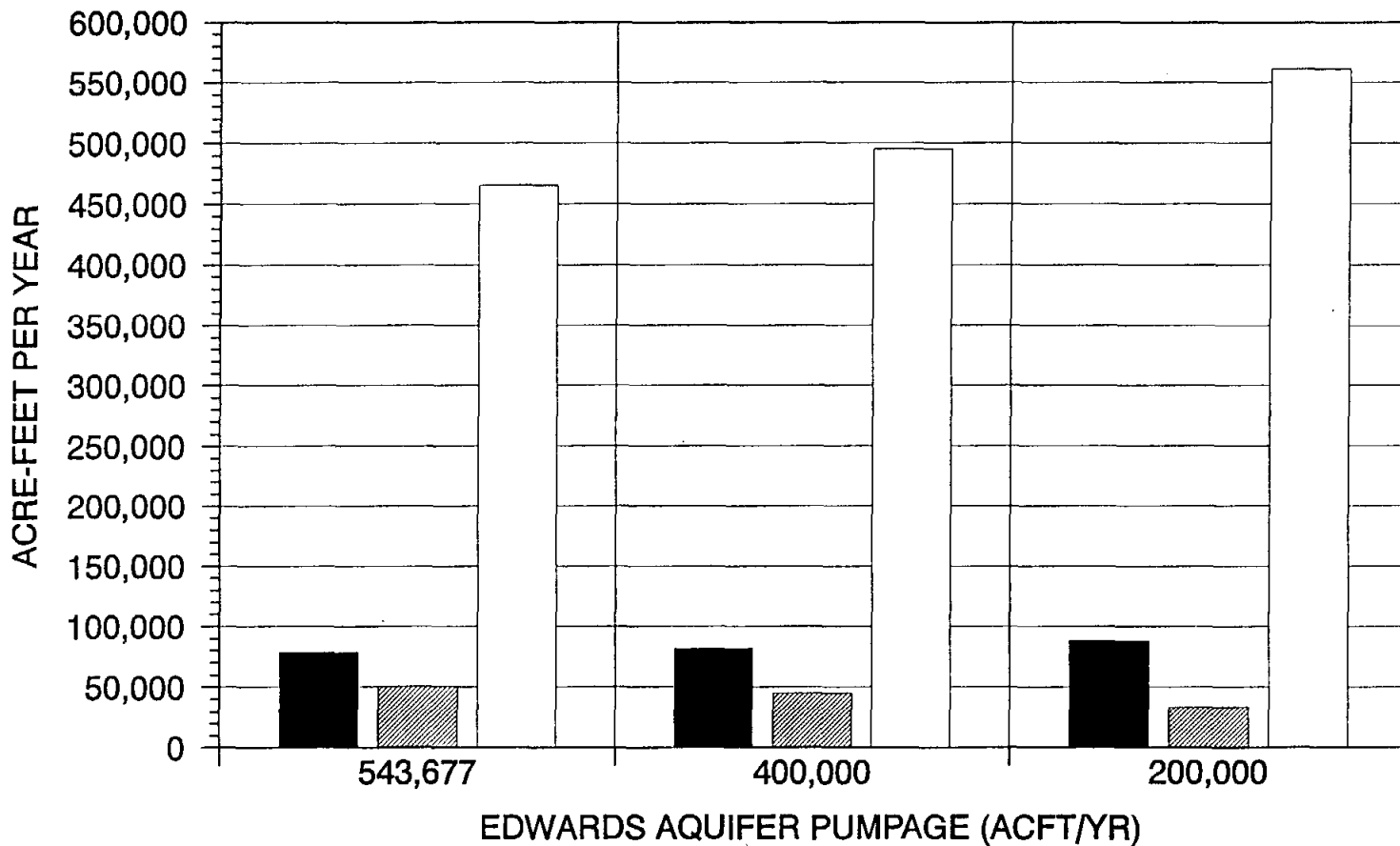

LEGEND:

- TOTAL CANYON LAKE FIRM YIELD
- ▨ DROUGHT AVERAGE RIGHTS SHORTAGES
- DROUGHT AVERAGE FLOW BELOW TIVOLI

ASSUMPTIONS:

1. SPRINGFLOWS BASED ON FIXED ANNUAL PUMPAGE SIMULATED BY THE TWDB EDWARDS AQUIFER MODEL AND ADJUSTED FOR DIFFERENCES BETWEEN SIMULATED AND OBSERVED HISTORICAL SPRINGFLOWS.
2. HYDROPOWER WATER RIGHTS FULLY SUBORDINATED TO CANYON LAKE.
3. UNCOMMITTED FIRM YIELD OF CANYON LAKE DIVERTED NEAR NEW BRAUNFELS.
4. RETURN FLOWS SET AT RATES OBSERVED IN 1989.
5. SIMULATED SHORTAGES BASED ON WATER RIGHTS ON THE SAN MARCOS RIVER BELOW SAN MARCOS AND THE GUADALUPE RIVER BELOW NEW BRAUNFELS FOR THE 1947-56 HISTORICAL PERIOD.
6. AVERAGE SIMULATED FLOWS BELOW THE SALTWATER BARRIER AT TIVOLI FOR THE 1947-56 HISTORICAL PERIOD.

TRANS TEXAS WATER PROGRAM /
WEST CENTRAL STUDY AREA



HDR Engineering, Inc.

**POTENTIAL EFFECTS OF
EDWARDS AQUIFER
PUMPAGE LIMITATIONS**

FIGURE J5-1

enhanced springflow at San Marcos Springs could be available for diversion after honoring existing surface water rights. The lesser percentages during drought below San Marcos Springs are primarily due to inclusion of a water rights permit application by the City of San Marcos currently under consideration by the Texas Natural Resources Conservation Commission (TNRCC).

Water Rights Transfer

Review of records of reported surface water use provided by the TNRCC indicates that less than 40 percent of existing diversion rights in the Guadalupe - San Antonio River Basin (including pending applications by the Cities of Victoria and San Marcos which are currently under consideration by the TNRCC) were utilized in calendar year 1989. Figure J5-2 provides comparisons of diversion rights and 1989 reported use for selected stream reaches. In 1989, utilization of diversion rights for the stream reaches shown in Figure J5-2 ranged from 9 percent to 44 percent. For Alternative G-33, it was assumed that the portion of all existing rights which were not utilized in 1989 could be transferred by purchase or lease to supplement water potentially available for diversion below Comal or San Marcos Springs. After adjusting water rights to 1989 reported uses, accounting for diversions under enhanced springflow, and preserving unappropriated streamflow at the Saltwater Barrier, water potentially available for diversion under the transfer of existing, unutilized rights was computed using the GSA Model. Trans-Texas Environmental Criteria were not applied as these diversions would be made under existing water rights and freshwater inflows to the Guadalupe Estuary would remain unchanged or increase due to enhanced springflow.

Unappropriated Flow

The GSA Model was used to calculate unappropriated streamflow potentially available for diversion from Lake Dunlap after accounting for diversions under enhanced springflow and water rights transfers. Unappropriated streamflow was calculated subject to Trans-Texas Environmental Criteria for Instream Flows and for Freshwater Inflows to Bays & Estuaries (Appendix C, Volume 2).

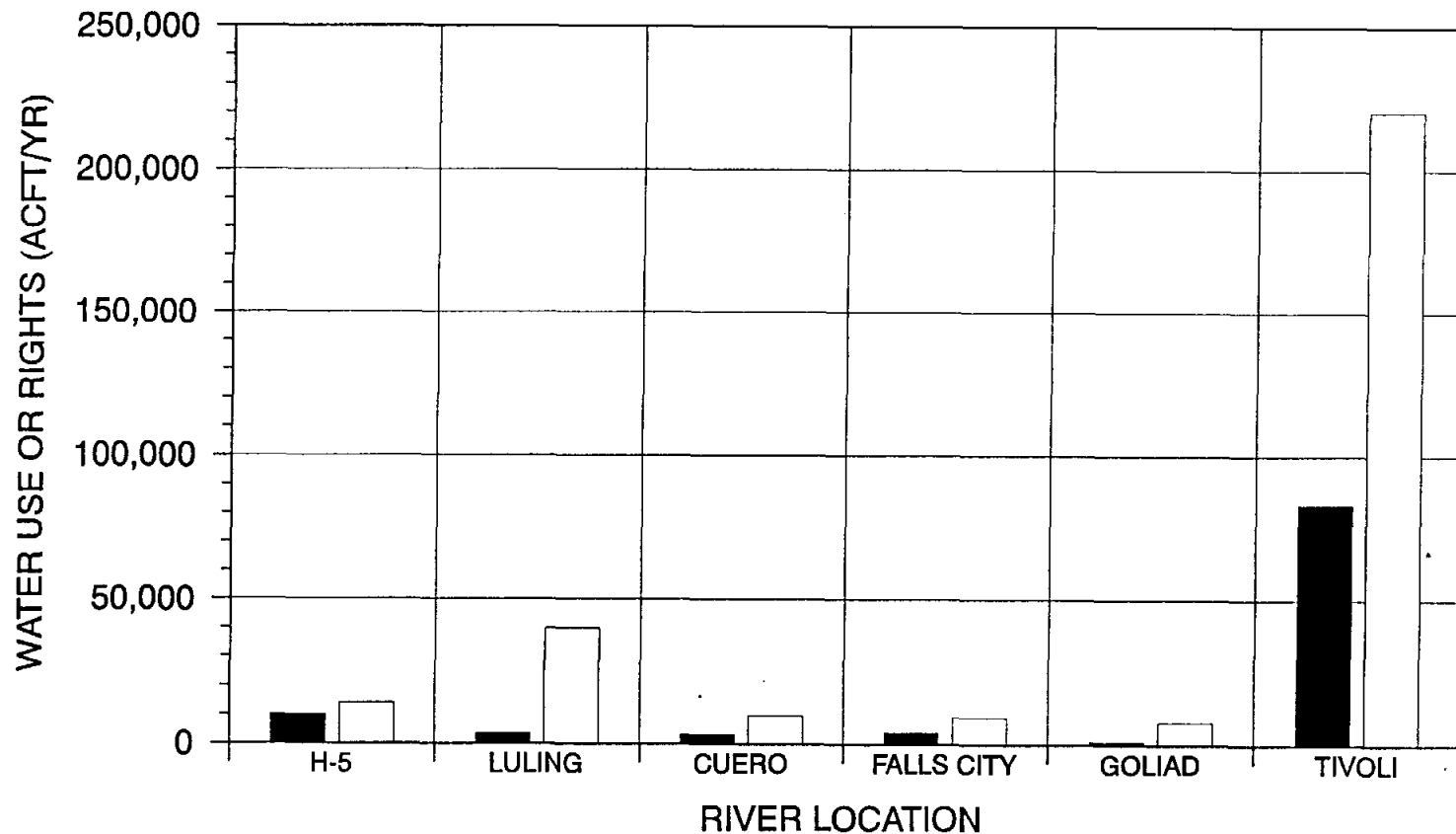

LEGEND:

- REPORTED USE
- WATER RIGHTS

ASSUMPTIONS:

1. WATER RIGHTS UTILIZATION OBTAINED FROM TNRCC RECORDS AND SUMMARIZED BY RIVER REACH.
2. EXAMPLE RIVER REACHES DEFINED AS FOLLOWS:
 - H-5 = GUADALUPE AND COMAL RIVERS FROM NEW BRAUNFELS TO LAKE WOOD
 - LULING = SAN MARCOS RIVER FROM SAN MARCOS TO LULING
 - CUERO = SAN MARCOS AND GUADALUPE RIVERS FROM LULING AND LAKE WOOD TO CUERO INCLUDING PLUM AND PEACH CREEKS
 - FALLS CITY = SAN ANTONIO RIVER FROM ELMENDORF TO FALLS CITY
 - GOLIAD = SAN ANTONIO RIVER AND CIBOLO CREEK FROM FALLS CITY TO GOLIAD
 - TIVOLI = GUADALUPE AND SAN ANTONIO RIVERS FROM VICTORIA AND GOLIAD, RESPECTIVELY, TO THE SALTWATER BARRIER

TRANS TEXAS WATER PROGRAM /
WEST CENTRAL STUDY AREA



HDR Engineering, Inc.

**UTILIZATION OF
EXISTING WATER RIGHTS
CALENDAR YEAR 1989**

FIGURE J5-2

Total Water Availability

Combining water potentially available from each of these sources to obtain total water availability as a function of maximum diversion rate is summarized in Figure J5-3 for diversions below Comal Springs (Alternative G-33A) and in Figure J5-4 for diversions below San Marcos Springs (Alternative G-33B). The estimates of water potentially available for diversion at these two locations are mutually exclusive and, therefore, may not be added to one another.

Total quantities of water potentially available under this alternative (prior to limitation by maximum diversion rate) can be quite variable from year to year as illustrated for diversions below Comal Springs in Figure J5-5. Figure J5-5 is also indicative of the relative availability of water from enhanced springflow, 1989 unutilized water rights, and unappropriated flow subject to two Edwards Aquifer pumpage rates and 56 years of variable weather conditions.

Figure J5-3

Figure J5-4

200,000 ACFT/YR EDWARDS AQUIFER PUMPAGE

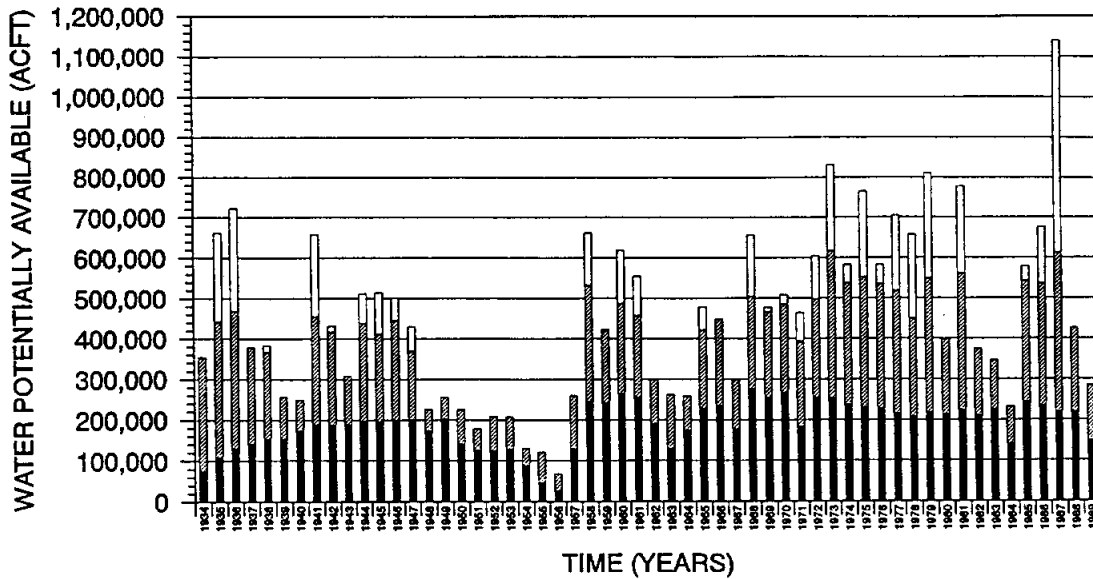

400,000 ACFT/YR EDWARDS AQUIFER PUMPAGE

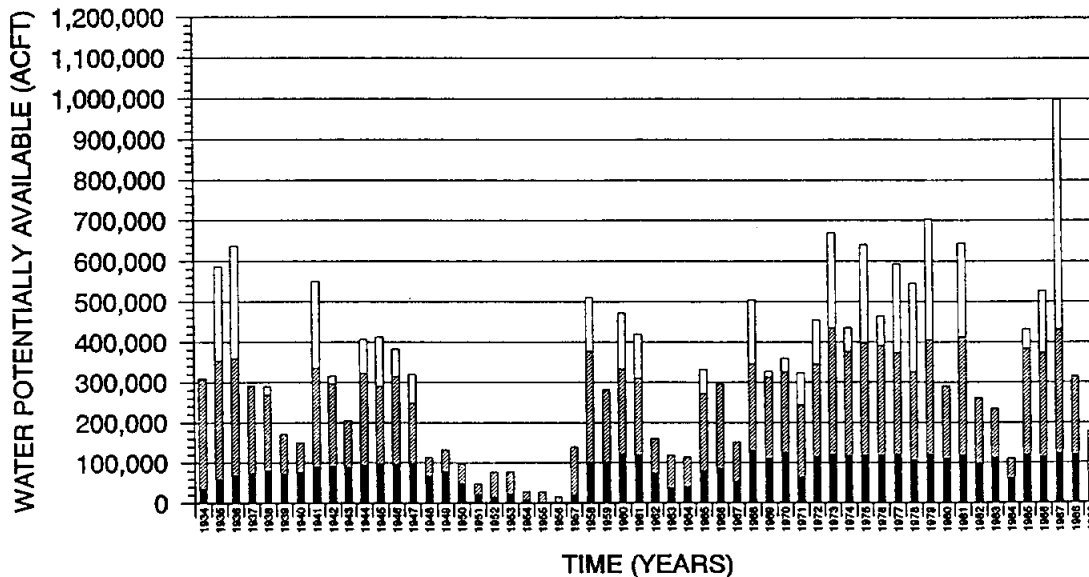

LEGEND:

- ENHANCED SPRINGFLOW
- ▨ 1989 UNUTILIZED RIGHTS
- UNAPPROPRIATED FLOW

ASSUMPTIONS:

1. DIVERSION FROM GUADALUPE RIVER AT LAKE DUNLAP. ANNUAL WATER AVAILABILITY UNRESTRICTED BY CAPACITY OF DIVERSION FACILITIES.
2. HYDROPOWER WATER RIGHTS FULLY SUBORDINATED TO CANYON LAKE.
3. UNCOMMITTED FIRM YIELD OF CANYON LAKE DIVERTED NEAR NEW BRAUNFELS AND BASED ON SPRINGFLOWS RESULTING FROM FIXED EDWARDS AQUIFER PUMPAGE OF 543,677 ACFT/YR.
4. RETURN FLOWS SET AT RATES OBSERVED IN 1989
5. UNAPPROPRIATED STREAMFLOW SUBJECT TO ORIGINAL TRANS-TEXAS ENVIRONMENTAL CRITERIA.



HDR Engineering, Inc.

TRANS TEXAS WATER PROGRAM / WEST CENTRAL STUDY AREA

ANNUAL WATER AVAILABILITY BELOW COMAL SPRINGS ALTERNATIVE G-33A

FIGURE J5-5

APPENDIX K

**SUMMARY OF POTENTIAL
WATER SUPPLY ALTERNATIVES**

Table ES-12

Summary of Potential Water Supply Alternatives For the Trans-Texas Water Program, West Central Study Area, Volume 4

Alternative	Firm Water Supply ¹ (acft/yr)	Unit Cost of Additional Water (1994 Dollars) (\$/acft/yr)					Environmental Issues/ Special Concerns
		Natural Recharge	Imported Recharge		Treatment & Municipal Distribution	Other	
			Without Treatment	With Treatment			
G-30 Guadalupe River Diversion Near Comfort to Recharge Zone Via Medina Lake							Reductions in Guadalupe River flow above Canyon Lake. Original Trans-Texas Environmental Criteria for Instream Flows applied at point of diversion. Potential impacts to terrestrial and karst inhabitants and to Edwards Aquifer fauna will vary with recharge/impoundment location. Includes cost of Canyon Lake firm yield reduction. Interbasin transfer.
a. Drought Average (1947-56)	9,900	\$ 711					
b. Long Term Average (1934-89)	37,800	\$ 239					
G-32 Diversion of Canyon Lake Flood Storage to Recharge Zone via Cibolo Creek							Potential impacts to terrestrial and karst inhabitants and to Edwards Aquifer fauna. No recharge enhancement during critical drought as Canyon Lake does not fill. No environmental streamflow criteria applied. Interbasin transfer.
a. Drought Average (1947-56)	-0-	N/A					
b. Long Term Average (1934-89)	16,100	\$740					
G-33 Guadalupe River Diversion Near Lake Dunlap to Recharge Zone with Enhanced Springflow, Water Rights Transfer, and Unappropriated Streamflow							Reductions in Guadalupe River flow above San Marcos River confluence. No environmental streamflow criteria applied to diversions under enhanced springflow and water rights transfers. Original Trans-Texas Environmental Criteria applied to diversions under unappropriated streamflow. Potential impacts to terrestrial and karst inhabitants and to Edwards Aquifer fauna will vary with recharge/impoundment location. Includes cost of water rights transfers. Interbasin transfer.
a. Drought Average (1947-56)	70,300	\$ 389					
b. Long Term Average (1934-89)	123,200	\$ 264					

(1) WATER SUPPLY VALUES FOR EACH ALTERNATIVE ARE ON A STAND-ALONE BASIS AND CANNOT BE ADDED TO OTHER ALTERNATIVES IN THEIR PRESENT FORM. NOTE: Alternatives are classified into four categories: Natural Recharge is recharge to the aquifer with water originating from the Edwards Plateau catchment, recharge zone, or from springs originating from the Edwards Aquifer. Natural recharge to the aquifer can be accomplished through an injection well or recharge zone. Imported Recharge is recharge to the aquifer with all or a portion of the water originating from sources other than those listed under Natural Recharge, regardless of the delivery system into the aquifer. Treatment and Distribution considers alternatives which would include conventional water treatment, or just disinfection in the case of Carrizo water. Distribution costs will be based on costs as estimated in previous studies for delivery to the SAWS system. Other use includes demand reduction or conservation, reclaimed water reuse, transfer of water through purchase or lease, and treatment of brackish water by demineralization.

Table ES-12, continued
Summary of Potential Water Supply Alternatives For the Trans-Texas Water Program, West Central Study Area, Volume 4

Alternative	Firm Water Supply ¹ (acft/yr)	Unit Cost of Additional Water (1994 Dollars) (\$/acft/yr)					Environmental Issues/ Special Concerns
		Natural Recharge	Imported Recharge		Treatment & Municipal Distribution	Other	
			Without Treatment	With Treatment			
S-15D Cibolo Reservoir with Imported Water							Reductions in streamflow below points of diversion and Cibolo Creek Reservoir. Original Trans-Texas Environmental Criteria applied except with respect to diversion of SAWS reclaimed water and diversions from the Colorado River. Riverine habitats converted to lake habitats. Terrestrial habitat impacts. Interbasin transfers.
a. San Antonio River Only	75,600				\$ 703		
b. San Antonio and Guadalupe Rivers	79,600				\$ 811		
c. San Antonio, Guadalupe, and Colorado Rivers	162,900				\$ 713		
S-15E Cibolo Reservoir with Imported Water							Reductions in streamflow below points of diversion and Cibolo Creek Reservoir. Original Trans-Texas Environmental Criteria applied except with respect to diversion of SAWS reclaimed water and diversions from the Colorado River. Riverine habitats converted to lake habitats. Terrestrial habitat impacts. Interbasin transfer.
a. Saltwater Barrier Only	65,100				\$ 952		
b. Saltwater Barrier and Colorado River	132,000				\$ 776		
S-17 Upper Cibolo Creek Reservoir	8,700						Potential impacts to terrestrial and karst inhabitants and to Edwards Aquifer fauna. Riverine habitats converted to lake habitats. Terrestrial habitat impacts. Potential impacts to Natural Bridge Caverns and Bat Cave. Annual cost of conventional firm yield at reservoir with no conveyance or treatment is \$1,989/acft/yr.

(1) WATER SUPPLY VALUES FOR EACH ALTERNATIVE ARE ON A STAND-ALONE BASIS AND CANNOT BE ADDED TO OTHER ALTERNATIVES IN THEIR PRESENT FORM.
 NOTE: Alternatives are classified into four categories: Natural Recharge is recharge to the aquifer with water originating from the Edwards Plateau catchment, recharge zone, or from springs originating from the Edwards Aquifer. Natural recharge to the aquifer can be accomplished through an injection well or recharge zone. Imported Recharge is recharge to the aquifer with all or a portion of the water originating from sources other than those listed under Natural Recharge, regardless of the delivery system into the aquifer. Treatment and Distribution considers alternatives which would include conventional water treatment, or just disinfection in the case of Carrizo water. Distribution costs will be based on costs as estimated in previous studies for delivery to the SAWS system. Other use includes demand reduction by conservation, reclaimed water reuse, transfer of water through purchase or lease, and treatment of brackish water by demineralization.

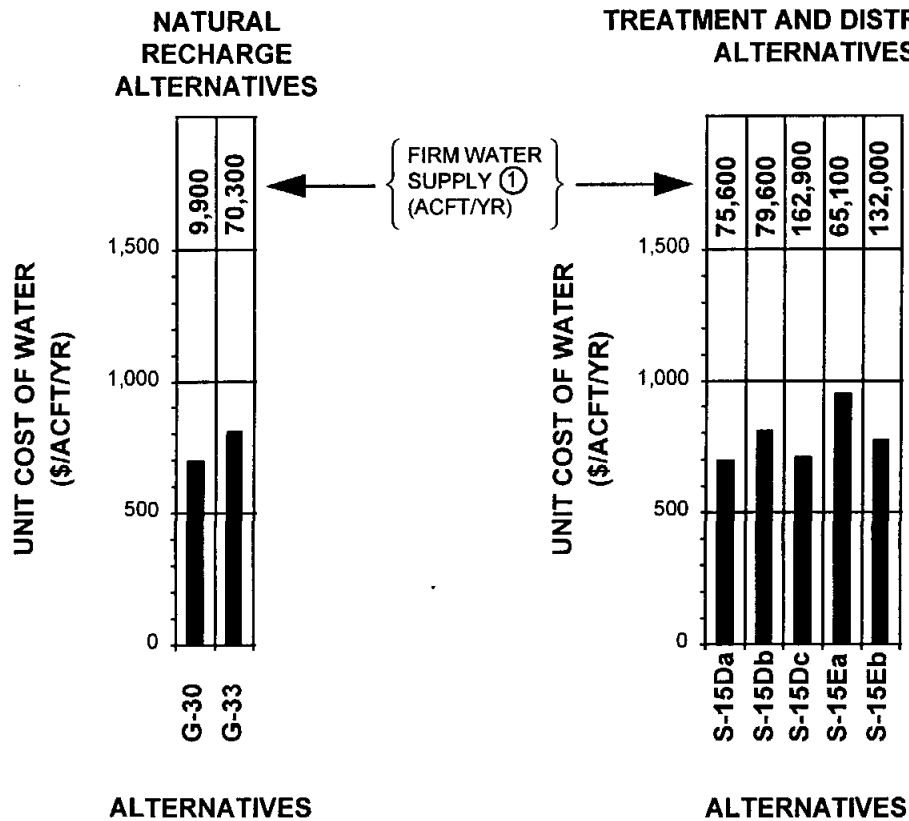

NOTES:

- FOR DESCRIPTION OF EACH ALTERNATIVE, SEE TABLE ES-12.
- ALTERNATIVES WITH UNIT COST GREATER THAN \$1500/ACFT/YR NOT SHOWN.

① WATER SUPPLY VALUES FOR EACH ALTERNATIVE ARE ON A STAND ALONE BASIS AND CANNOT, IN MANY CASES, BE ADDED TO OTHER ALTERNATIVES IN THEIR PRESENT FORM.

TRANS TEXAS WATER PROGRAM /
WEST CENTRAL STUDY AREA



HDR Engineering, Inc.

**SUMMARY OF UNIT COSTS AND
FIRM WATER SUPPLY FOR
ALTERNATIVES IN VOLUME 4**

FIGURE ES-12B

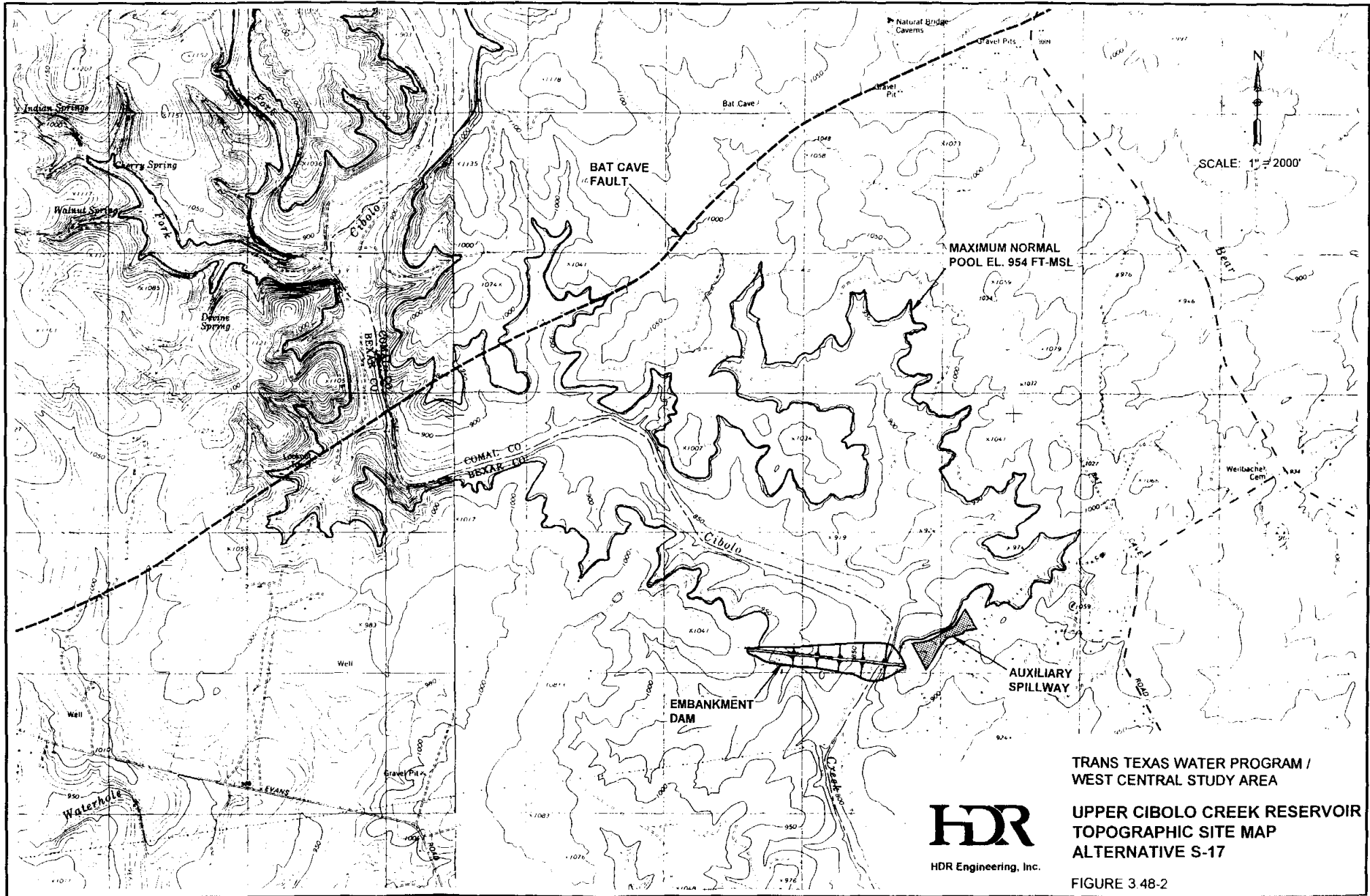

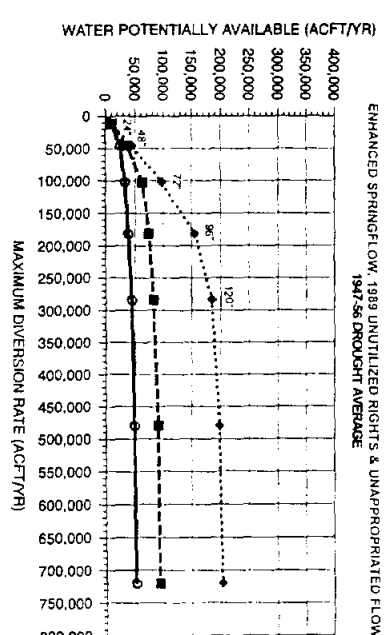
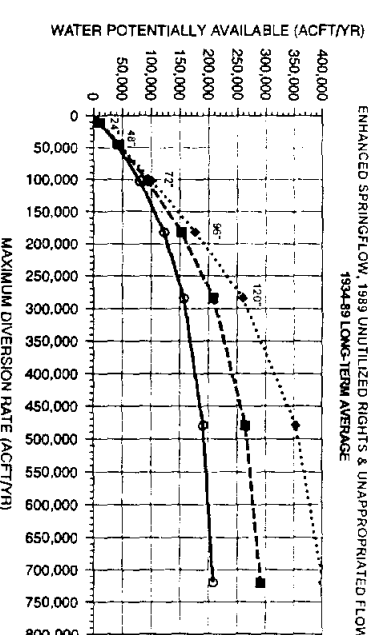
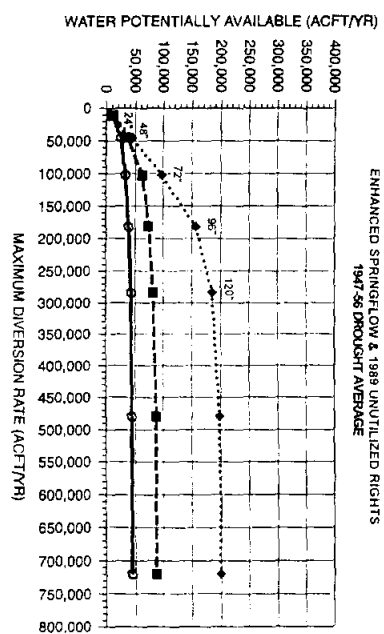
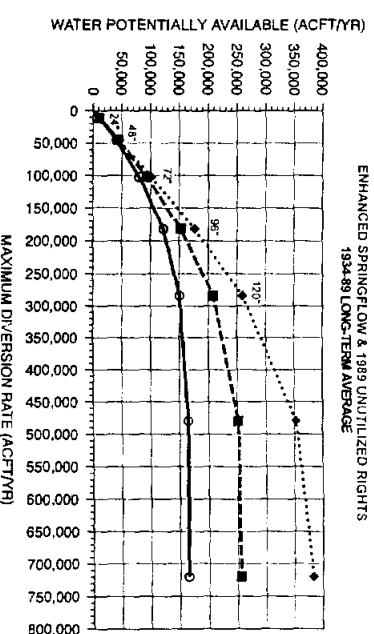
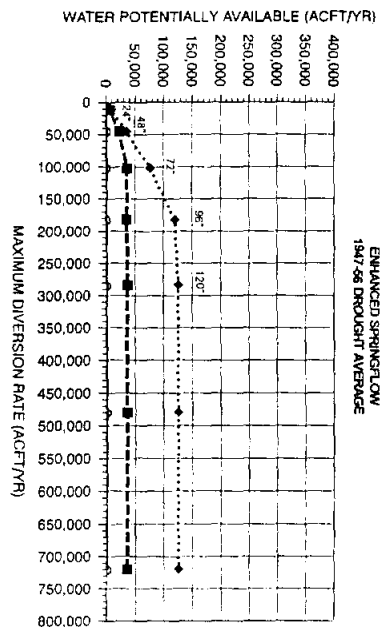
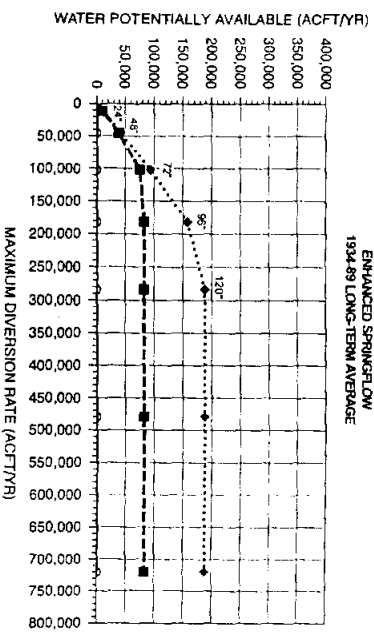

LEGEND:

- 200,000 ACFT/YR PUMPAGE
- - - 400,000 ACFT/YR PUMPAGE
- 543,977 ACFT/YR PUMPAGE

ASSUMPTIONS:

1. DIVERSIONS FROM GUADELUPE RIVER AT LAKE DUNKAP
2. HYDROPOWER WATER RIGHTS FULLY SUBORDINATED TO CANYON LAKE
3. UNCOMMITTED FIRM YIELD OF CANYON LAKE DIVERTED NEAR NEW BRUNN E.L.S. AND BAUL DIN
4. RETURN FLOWS RESULTING FROM FRIED EDWARDS AQUIFER PUMPAGE OF 543,977 ACFT/YR
5. UNAPPROPRIATED STREAMFLOW SUBJECT TO ORIGINAL TRANS-TEXAS ENVIRONMENTAL CRITERIA



TRANS TEXAS WATER PROGRAM /
WEST CENTRAL STUDY AREA
WATER AVAILABILITY SUMMARY
BELOW COMAL SPRINGS
ALTERNATIVE G-33A

HDR Engineering, Inc.

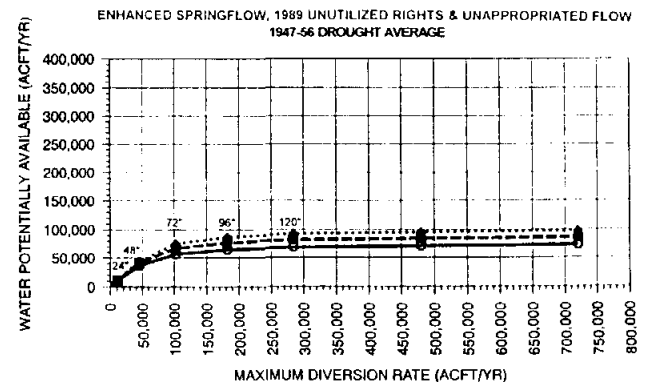
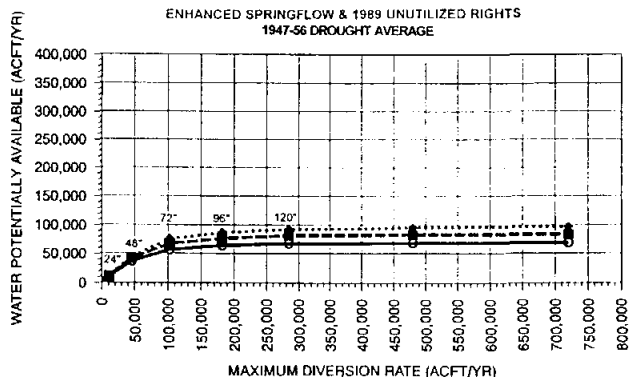
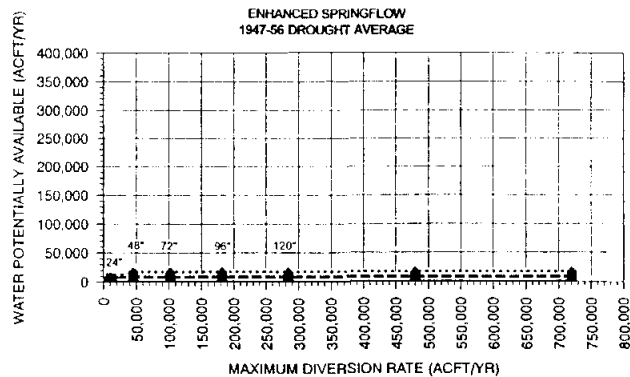
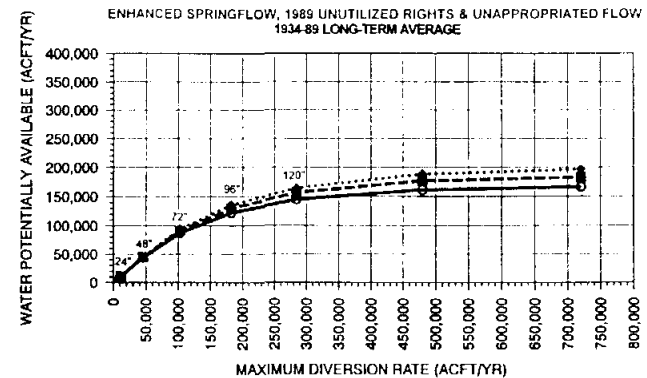
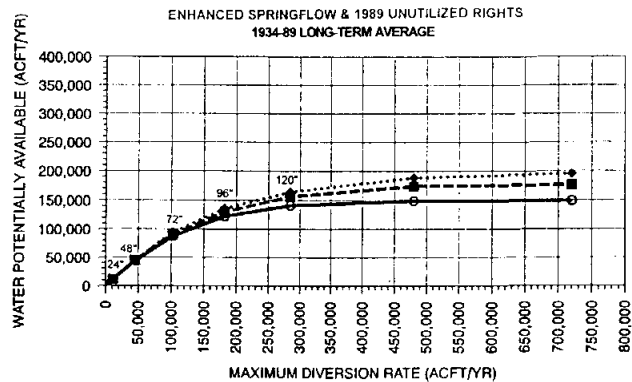
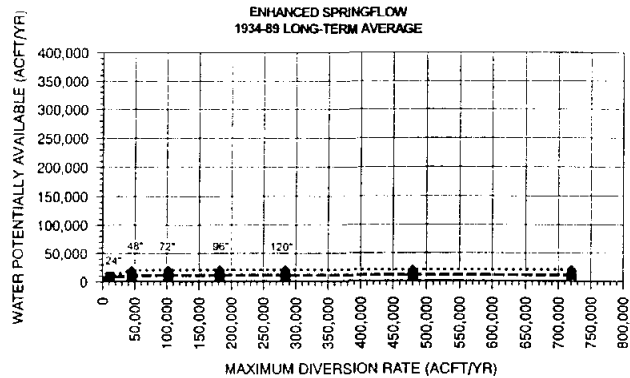

LEGEND:

- 200,000 ACFT/YR PUMPAGE
- 400,000 ACFT/YR PUMPAGE
- 543,677 ACFT/YR PUMPAGE

ASSUMPTIONS:

1. DIVERSIONS FROM SAN MARCOS RIVER AT CUMMINGS DAM
2. HYDROPOWER WATER RIGHTS FULLY SUBORDINATED TO CANYON LAKE
3. UNCOMMITTED FIRM YIELD OF CANYON LAKE DIVERTED NEAR NEW BRAUNFELS AND BASED ON SPRINGFLOWS RESULTING FROM FIXED EDWARDS AQUIFER PUMPAGE OF 543,677 ACFT/YR
4. RETURN FLOWS SET AT RATES OBSERVED IN 1989
5. UNAPPROPRIATED STREAMFLOW SUBJECT TO ORIGINAL TRANS TEXAS ENVIRONMENTAL CRITERIA

TRANS TEXAS WATER PROGRAM /
WEST CENTRAL STUDY AREA



HDR Engineering, Inc.

**WATER AVAILABILITY SUMMARY
BELOW SAN MARCOS SPRINGS
ALTERNATIVE G-33B**

FIGURE J5-4